

NOTES:
 1. GLAZING - .125" MINIMUM DSB GLAZING INSTALLED WITH ALUMINUM RETAINERS IN ORDER TO MEET UNIFORM STATIC DESIGN PRESSURES SHOWN ON THIS DRAWING. GLAZING IS NOT IMPACT RESISTANT AND DOES NOT MEET THE REQUIREMENTS FOR WIND-BORNE DEBRIS REGIONS.

2. MINIMUM OF 1" OVERLAP ON BOTH JAMBS REQUIRED TO MEET NEGATIVE DESIGN PRESSURES.

3. SLIDE LOCK OR OPERATOR REQUIRED.

4. ALL RAILS AND STILES SHALL BE EXTRUDED ALUMINUM ALLOY 6063-T6 WITH THE FOLLOWING MINIMUM THICKNESS:
 MODEL 400: 2"
 MODEL 451: 1-5/16"
 MODEL 452: 1-5/16"
 MODEL 8850: 1-5/16"

5. THE DESIGN OF THE SUPPORTING STRUCTURAL ELEMENTS SHALL BE THE RESPONSIBILITY OF THE PROFESSIONAL OF RECORD FOR THE BUILDING OR STRUCTURE AND IN ACCORDANCE WITH CURRENT BUILDING CODES FOR THE LOADS LISTED ON THIS DRAWING.

6. TRACK CLIPS SHALL BE LOCATED WITH CENTERLINE OF BOTTOM CLIP SPACED 10" MAX FROM BOTTOM OF TRACK AND REMAINING TRACK CLIPS SPACED AT 24" O.C. MAX. SPACING BETWEEN TOP TRACK CLIP AND SPLICE PLATE SHALL BE 30" O.C. MAX.

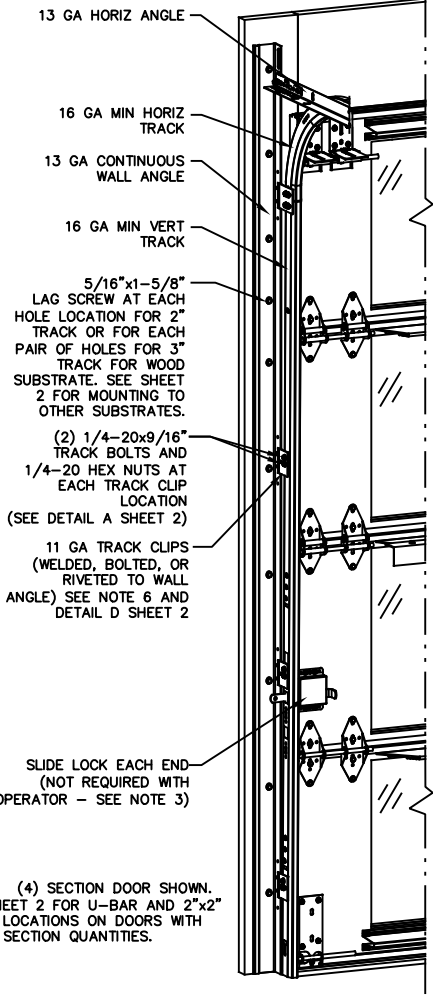

NOTE: (4) SECTION DOOR SHOWN. SEE SHEET 2 FOR U-BAR AND 2"x2" ANGLE LOCATIONS ON DOORS WITH OTHER SECTION QUANTITIES.

SUPERIMPOSED DESIGN PRESSURE LOADS ON SUPPORTING STRUCTURE

MAX DOOR WIDTH	DOOR HEIGHT	MAX UNIFORM LOAD EACH JAMB (PLF)
14'-2"	ALL	+219.6/-219.6

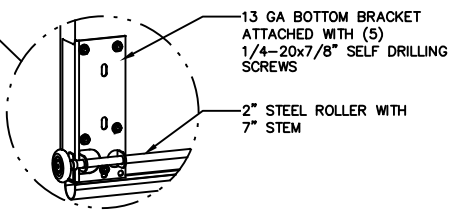
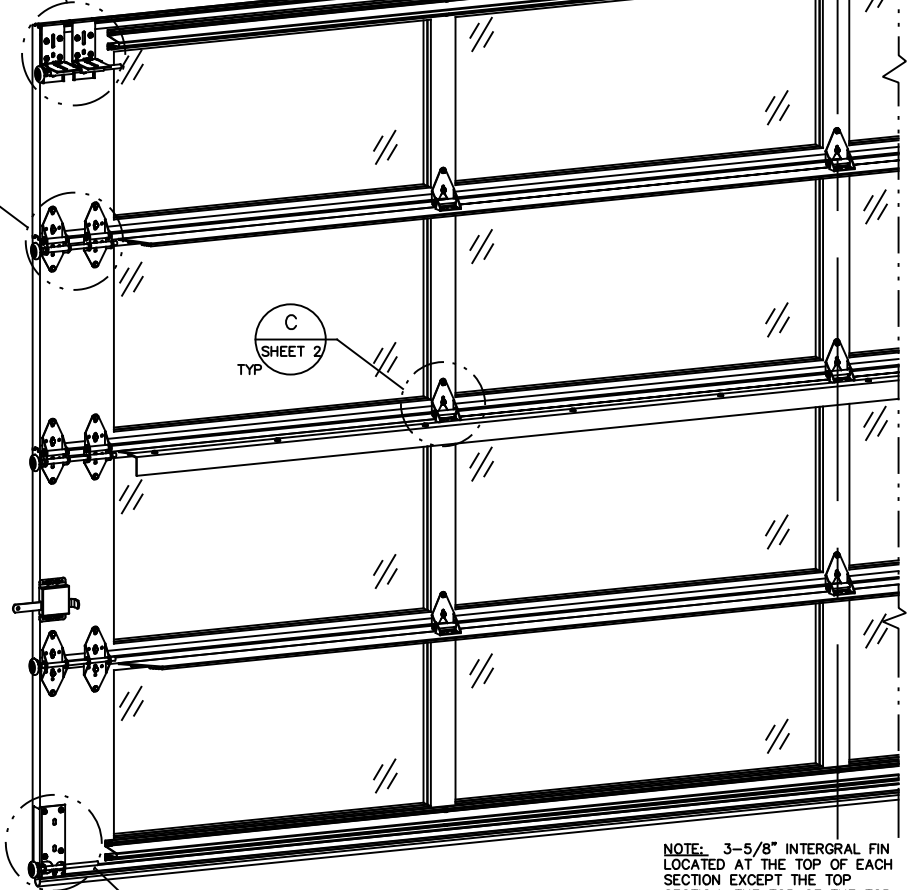
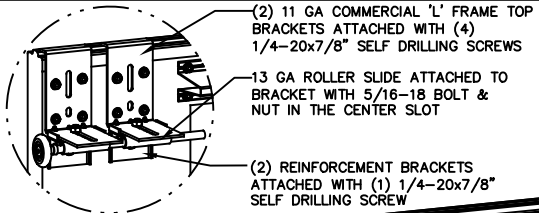

NOTE: 3-5/8" INTEGRAL FIN LOCATED AT THE TOP OF EACH SECTION EXCEPT THE TOP SECTION AND THE BOTTOM OF THE BOTTOM SECTION HAVE A 2-1/4" INTEGRAL FIN.

REVISIONS

P1 ADDED MODEL 400 TO OPTION CODE. UPDATED NOTE 4 FOR MODEL 400 THICKNESS. GRT 5/18/06

P2 CHANGED DIRECT MOUNT TO CONCRETE DETAIL FROM 5/16" POWERS LOK/BOLT SLEEVE TO SIMPSON TITEN HD SCREW ANCHOR GRT 5/25/07

P3 ADDED MODEL 8850. ADDED TEXAS LICENSE NUMBER TO TITLE BLOCK. ADDED TRACK CLIP DETAIL AND UPDATED DIRECT MOUNT DETAILS. GRT 11/05/08

MARK R. BARROW, PE
 FLORIDA LICENSE NO. 57389
 TEXAS LICENSE NO. 93119

Wayne Dalton
 3395 ADDISON DRIVE
 PENSACOLA, FLORIDA 32514
 (850) 474-9890

STATIC PRESSURE RATINGS		APPROVED SIZES		SCALE: N.T.S.		SIZE: A	
DESIGN (PSF):	+31.00/-31.00	MAX WIDTH:	14'-2"	DATE	NAME		
TEST (PSF):	+46.50/-46.50	MAX HEIGHT:	24'-1"	DRAWN	GRT		
IMPACT/CYCLIC RATED (YES/NO):	NO	MAX SECTION HEIGHT:	24"	CHECKED	MRB		
MODELS 400/451/452/8850				SHEET 1 OF 2			
WINDLOAD SPECIFICATION OPTION CODE 0452				DRAWING PART NO.	REV.		
				319016	P3		

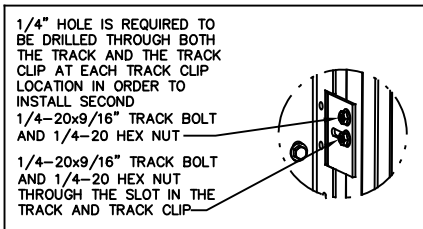

DETAIL A

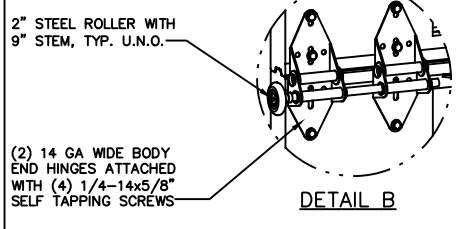

DETAIL B

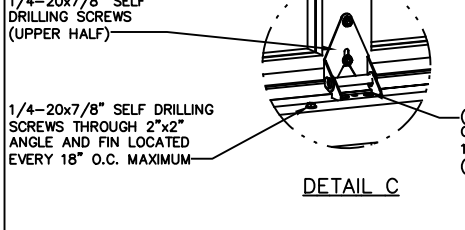

DETAIL C

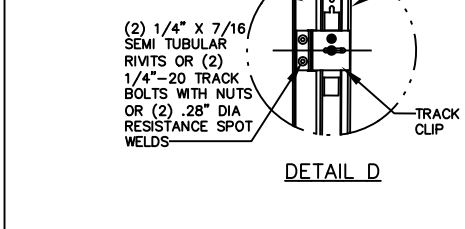

DETAIL D

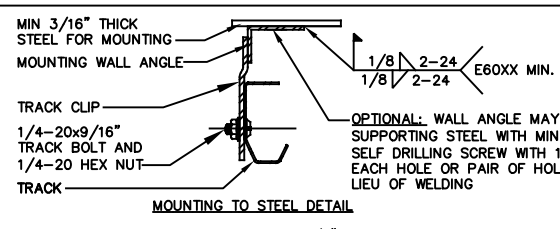

MOUNTING TO STEEL DETAIL

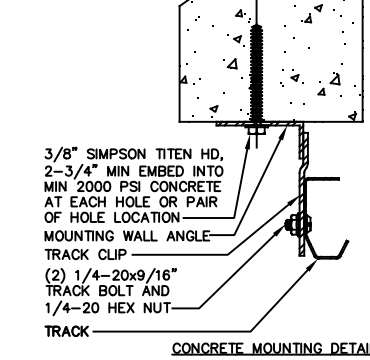

CONCRETE MOUNTING DETAIL

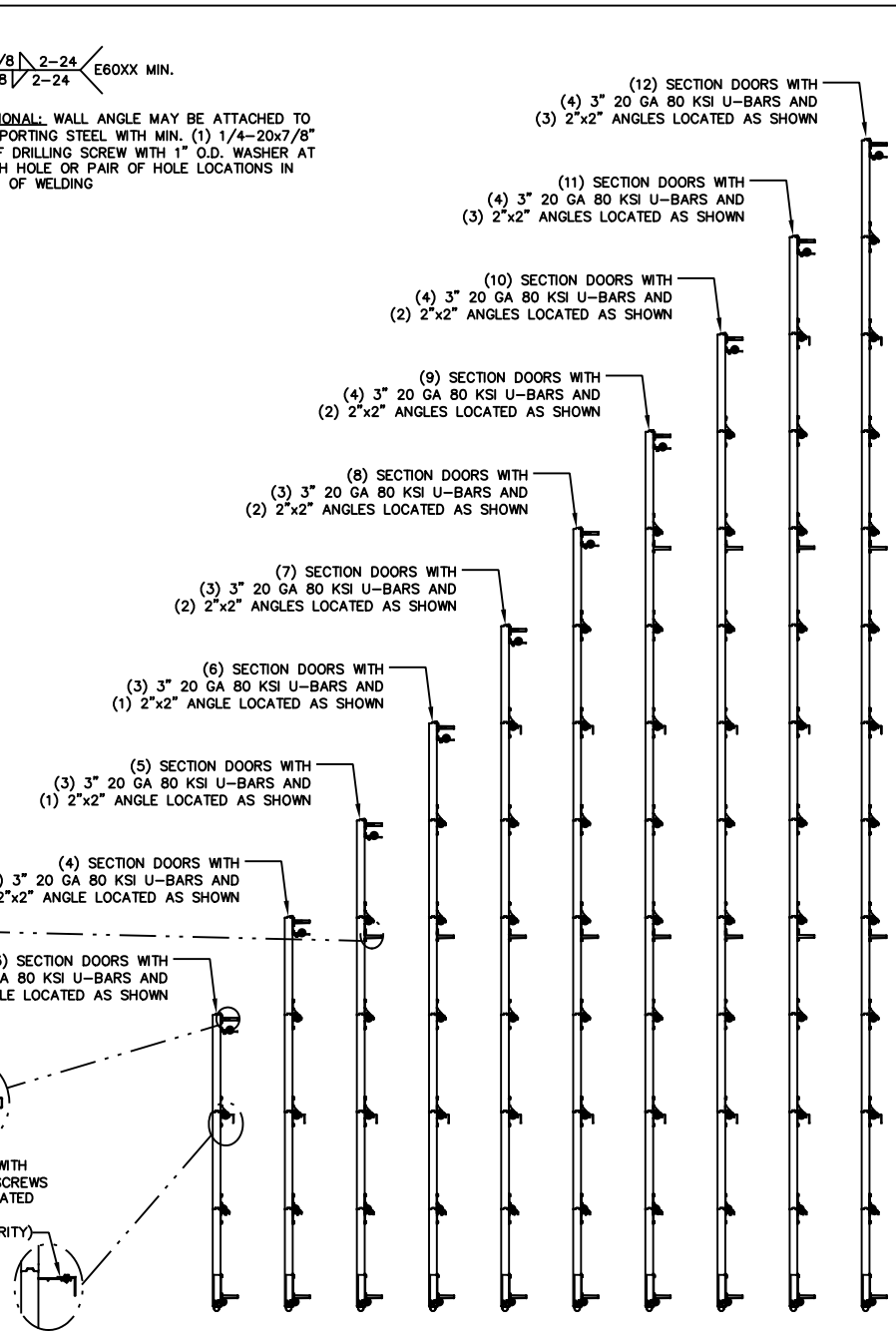
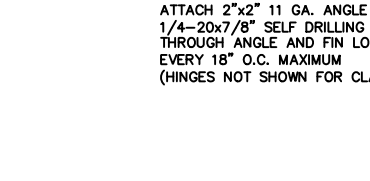
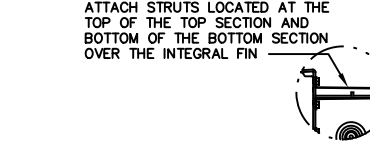
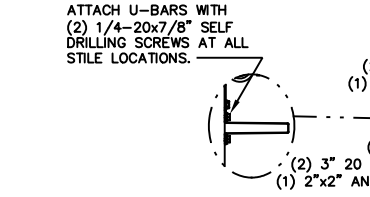

REVISIONS

- P1 ADDED MODEL 400 TO OPTION CODE. UPDATED NOTE 4 FOR MODEL 400 THICKNESS. GRT 5/18/06
- P2 CHANGED DIRECT MOUNT TO CONCRETE DETAIL FROM 5/16 inch POWERS LOK/BOLT SLEEVE TO SIMPSON TITEN HD SCREW ANCHOR GRT 5/25/07
- P3 ADDED MODEL 8850. ADDED TEXAS LICENSE NUMBER TO TITLE BLOCK. ADDED TRACK CLIP DETAIL AND UPDATED DIRECT MOUNT DETAILS. GRT 11/05/08

MARK R. BARROW, PE
FLORIDA LICENSE NO. 57389
TEXAS LICENSE NO. 93119

Wayne Dalton
3395 ADDISON DRIVE
PENSACOLA, FLORIDA 32514
(850) 474-9890

STATIC PRESSURE RATINGS		APPROVED SIZES		SCALE: N.T.S.	SIZE: A
DESIGN (PSF):	+31.00/-31.00	MAX WIDTH:	14'-2"	DATE	NAME
TEST (PSF):	+46.50/-46.50	MAX HEIGHT:	24'-1"	DRAWN	GRT
IMPACT/CYCLIC RATED (YES/NO):	NO	MAX SECTION HEIGHT:	24'	CHECKED	MRB
MODELS 400/451/452/8850				SHEET 2 OF 2	
WINDLOAD SPECIFICATION OPTION CODE 0452				DRAWING PART NO.	REV.
				319016	P3