

NOTES:

1. GLAZING - .125" MINIMUM DSB GLAZING INSTALLED WITH ALUMINUM RETAINERS IN ORDER TO MEET UNIFORM STATIC DESIGN PRESSURES SHOWN ON THIS DRAWING. GLAZING IS NOT IMPACT RESISTANT AND DOES NOT MEET THE REQUIREMENTS FOR WIND-BORNE DEBRIS REGIONS.

2. MINIMUM OF 1" OVERLAP ON BOTH JAMBS REQUIRED TO MEET NEGATIVE DESIGN PRESSURES.

3. SLIDE LOCK OR OPERATOR REQUIRED.

4. ALL RAILS AND STILES SHALL BE EXTRUDED ALUMINUM ALLOY 6063-T6 WITH THE FOLLOWING MINIMUM THICKNESS:
 MODEL 400: 2"
 MODEL 451: 1-5/16"
 MODEL 452: 1-5/16"
 MODEL 8850: 1-5/16"

5. THE DESIGN OF THE SUPPORTING STRUCTURAL ELEMENTS SHALL BE THE RESPONSIBILITY OF THE PROFESSIONAL OF RECORD FOR THE BUILDING OR STRUCTURE AND IN ACCORDANCE WITH CURRENT BUILDING CODES FOR THE LOADS LISTED ON THIS DRAWING.

6. TRACK CLIPS SHALL BE LOCATED WITH CENTERLINE OF BOTTOM CLIP SPACED 10" MAX FROM BOTTOM OF TRACK AND REMAINING TRACK CLIPS SPACED AT 24" O.C. MAX. SPACING BETWEEN TOP TRACK CLIP AND SPLICE PLATE SHALL BE 30" O.C. MAX.

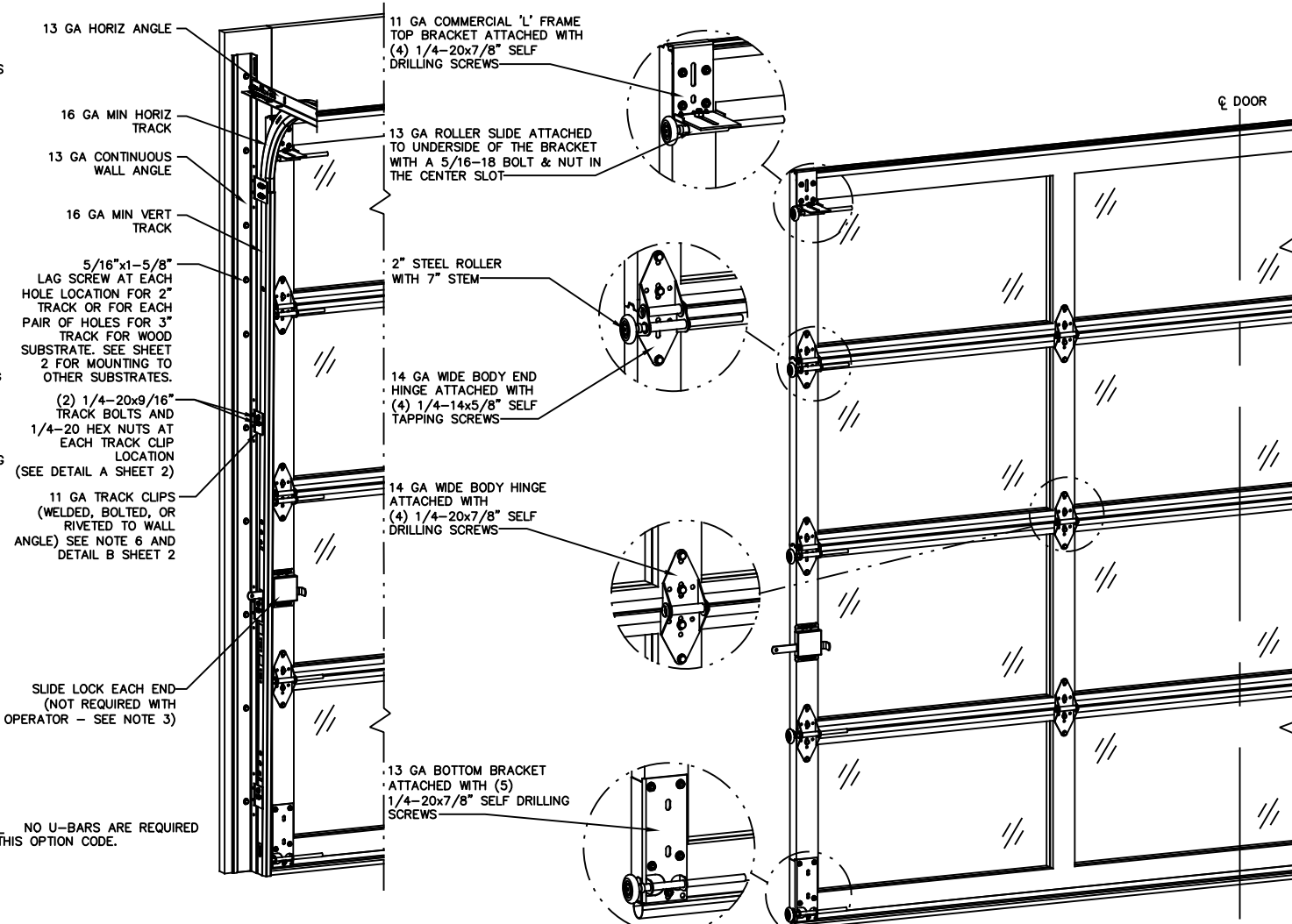

NOTE: NO U-BARS ARE REQUIRED FOR THIS OPTION CODE.

SUPERIMPOSED DESIGN PRESSURE LOADS ON SUPPORTING STRUCTURE		
MAX DOOR WIDTH	DOOR HEIGHT	MAX UNIFORM LOAD EACH JAMB (PLF)
10'-2"	ALL	+101.7/-101.7

REVISIONS

- P1 ADDED MODEL 400 TO OPTION CODE. UPDATED NOTE 4 FOR MODEL 400 THICKNESS. GRT 5/18/06
- P2 CHANGED DIRECT MOUNT TO CONCRETE DETAIL FROM 5/16" POWERS LOK/BOLT SLEEVE TO SIMPSON TITEN HD SCREW ANCHOR GRT 5/25/07
- P3 ADDED MODEL 8850. ADDED TEXAS LICENSE NUMBER TO TITLE BLOCK. ADDED TRACK CLIP DETAIL AND UPDATED DIRECT MOUNT DETAILS. GRT 11/05/08



3395 ADDISON DRIVE
 PENSACOLA, FLORIDA 32514
 (850) 474-9890

STATIC PRESSURE RATINGS		APPROVED SIZES		SCALE: N.T.S.	SIZE: A
DESIGN (PSF):	+20.00/-20.00	MAX WIDTH:	10'-2"	DATE	NAME
TEST (PSF):	+30.00/-30.00	MAX HEIGHT:	24'-1"	DRAWN	GRT
IMPACT/CYCLIC RATED (YES/NO):	NO	MAX SECTION HEIGHT: 24"	CHECKED	3/15/06	MRB
MODELS 400/451/452/8850				SHEET 1 OF 2	
WINDLOAD SPECIFICATION OPTION CODE 0449				DRAWING PART NO.	REV.
				319013	P3

MARK R. BARROW, PE
 FLORIDA LICENSE NO. 57389
 TEXAS LICENSE NO. 93119

1/4" HOLE IS REQUIRED TO BE DRILLED THROUGH BOTH THE TRACK AND THE TRACK CLIP AT EACH TRACK CLIP LOCATION IN ORDER TO INSTALL SECOND 1/4"-20x9/16" TRACK BOLT AND 1/4"-20 HEX NUT.

1/4"-20x9/16" TRACK BOLT AND 1/4"-20 HEX NUT THROUGH THE SLOT IN THE TRACK AND TRACK CLIP

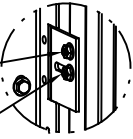

DETAIL A

CONTINUOUS WALL ANGLE

TRACK

TRACK CLIP

(2) 1/4" X 7/16" SEMI TUBULAR RIVETS OR (2) 1/4"-20 TRACK BOLTS WITH NUTS OR (2) .28" DIA RESISTANCE SPOT WELDS

DETAIL B

MIN 3/16" THICK STEEL FOR MOUNTING

MOUNTING WALL ANGLE

TRACK CLIP

1/4"-20x9/16" TRACK BOLT AND 1/4"-20 HEX NUT

TRACK

OPTIONAL: WALL ANGLE MAY BE ATTACHED TO SUPPORTING STEEL WITH MIN. (1) 1/4"-20x7/8" SELF DRILLING SCREW WITH 1" O.D. WASHER AT EACH HOLE OR PAIR OF HOLE LOCATIONS IN LIEU OF WELDING

MOUNTING TO STEEL DETAIL

2 3/4" MIN EDGE DIST

3/8" SIMPSON TITEN HD, 2-3/4" MIN EMBED INTO MIN 2000 PSI CONCRETE AT EACH HOLE OR PAIR OF HOLE LOCATION

MOUNTING WALL ANGLE

TRACK CLIP

(2) 1/4"-20x9/16" TRACK BOLT AND 1/4"-20 HEX NUT

TRACK

CONCRETE MOUNTING DETAIL

REVISIONS

P1 ADDED MODEL 400 TO OPTION CODE. UPDATED NOTE 4 FOR MODEL 400 THICKNESS.
GRT 5/18/06

P2 CHANGED DIRECT MOUNT TO CONCRETE DETAIL FROM 5/16" POWERS LOK/BOLT SLEEVE TO SIMPSON TITEN HD SCREW ANCHOR
GRT 5/25/07

P3 ADDED MODEL 8850. ADDED TEXAS LICENSE NUMBER TO TITLE BLOCK. ADDED TRACK CLIP DETAIL AND UPDATED DIRECT MOUNT DETAILS.
GRT 11/05/08

MARK R. BARROW, PE
FLORIDA LICENSE NO. 57389
TEXAS LICENSE NO. 93119



3395 ADDISON DRIVE
PENSACOLA, FLORIDA 32514
(850) 474-9890

STATIC PRESSURE RATINGS		APPROVED SIZES		SCALE: N.T.S.	SIZE: A
DESIGN (PSF):	+20.00/-20.00	MAX WIDTH:	10'-2"	DATE	NAME
TEST (PSF):	+30.00/-30.00	MAX HEIGHT:	24'-1"	DRAWN	GRT
IMPACT/CYCLIC RATED (YES/NO): NO		MAX SECTION HEIGHT: 24"	CHECKED	3/15/06	MRB
MODELS 400/451/452/8850				SHEET 2 OF 2	
WINDLOAD SPECIFICATION OPTION CODE 0449				DRAWING PART NO.	REV.
				319013	P3