

# Model 8700

EXTENSION

RESIDENTIAL

STANDARD LIFT

QUICK START GUIDE

## Table Of Contents

<b>Pre-Installation</b>	<b>2</b>
Important Safety Instructions	2
Removing an Existing Door and Preparing the Opening	2
<b>Breakdown Of Parts</b>	<b>4</b>
<b>Door Installation Instructions</b>	<b>5</b>
<b>Counterbalance Installation Instructions</b>	<b>8</b>
<b>Maintenance</b>	<b>11</b>
Cleaning Your Garage Door	11
Operation And Maintenance	11
<b>Warranty</b>	<b>12</b>

### **PLEASE DO NOT RETURN THIS PRODUCT TO THE STORE**

If you need assistance, please call 1-866-569-3799 (press Option 1) and follow the prompts to contact a customer service representative. They will be happy to handle any questions that you may have.

### **QUICK START GUIDE IMPORTANT NOTICES!**

This **Quick Start Guide is only meant to be used as an aid** and / or introduction to garage door installation, and does not replace the complete Installation Instructions and Owner's manual available on the web at [www.Wayne-Dalton.com](http://www.Wayne-Dalton.com). Wayne Dalton highly recommends that you read and fully understand the Installation Instructions and Owner's Manual before you attempt this installation.

To avoid possible injury, read and fully understand the enclosed instructions carefully before installing and operating the garage door. Pay close attention to all warnings and notes. After installation is complete, fasten this manual near garage door for easy reference.

The complete Installation Instructions and Owner's Manual are available at no charge from:

- Your local Wayne Dalton Sales Center, or
- Online at [www.Wayne-Dalton.com](http://www.Wayne-Dalton.com), or
- By mailing to: Wayne Dalton, a division of Overhead Door Corporation, P.O. Box 67, Mt. Hope, OH., 44660

## Important Safety Instructions

### DEFINITION OF KEY WORDS USED IN THIS MANUAL:

#### **WARNING**

INDICATES A POTENTIALLY HAZARDOUS SITUATION WHICH, IF NOT AVOIDED, COULD RESULT IN SEVERE OR FATAL INJURY.

#### **CAUTION**

PROPERTY DAMAGE OR INJURY CAN RESULT FROM FAILURE TO FOLLOW INSTRUCTIONS.

**IMPORTANT:** REQUIRED STEP FOR SAFE AND PROPER DOOR OPERATION.

**NOTE:** Information assuring proper installation of the door.

**READ THESE INSTRUCTIONS CAREFULLY BEFORE ATTEMPTING INSTALLATION. IF IN QUESTION ABOUT ANY OF THE PROCEDURES, DO NOT PERFORM THE WORK. INSTEAD, HAVE A TRAINED DOOR SYSTEMS TECHNICIAN DO THE INSTALLATION OR REPAIRS.**

1. READ AND FOLLOW ALL INSTALLATION INSTRUCTIONS.
2. Wear protective gloves during installation to avoid possible cuts from sharp metal edges.
3. It is always recommended to wear eye protection when using tools, otherwise eye injury could result.
4. Avoid installing your new door on windy days. Door could fall during the installation causing severe or fatal injury.
5. Doors 12'-0" wide and over should be installed by two persons, to avoid possible injury.
6. Operate door only when it is properly adjusted and free from obstructions.
7. If a door becomes hard to operate, inoperative or is damaged, immediately have necessary adjustments and/ or repairs made by a trained door system technician using proper tools and instructions.
8. DO NOT stand or walk under a moving door, or permit anybody to stand or walk under an electrically operated door.
9. DO NOT place fingers or hands into open section joints when closing a door. Use lift handles/ gripping points when operating door manually.
10. DO NOT permit children to operate garage door or door controls. Severe or fatal injury could result should the child become entrapped between the door and the floor.
11. Due to constant extreme spring tension, do not attempt any adjustment, repair or alteration to any part of the door, especially to springs, spring brackets, bottom corner brackets, fasteners, counterbalance lift cables or supports. To avoid possible severe or fatal injury, have any such work performed by a trained door systems technician using proper tools and instructions.
12. On electrically operated doors, pull down ropes must be removed and locks must be removed or made inoperative in the open (unlocked) position.
13. Top section of door may need to be reinforced when attaching an electric opener. Check door and/ or opener manufacturer's instructions.
14. Visually inspect door and hardware monthly for worn and or broken parts. Check to ensure door operates freely.
15. Test electric opener's safety features monthly, following opener manufacturer's instructions.
16. NEVER hang tools, bicycles, hoses, clothing or anything else from horizontal tracks. Track systems are not intended or designed to support extra weight.
17. This door may not meet the building code wind load requirements in your area. For your safety, you will need to check with your local building official for wind load code requirements and building permit information.
18. For windloaded doors, the wind performance is achieved via the entire door system and component substitution is not authorized without express permission by Wayne Dalton.

**NOTE:** It is recommended that 5/16" lag screws are pilot drilled using a 3/16" drill bit, prior to fastening.



#### **CAUTION**

IF ANY PART OF THE DOOR IS TO BE INSTALLED ONTO PRESERVATIVE-TREATED WOOD, PTFE-COATED OR STAINLESS STEEL FASTENERS MUST BE OBTAINED AND USED. REPLACEMENT FASTENERS MUST BE OF AT LEAST EQUAL STRENGTH AND SIZE AS ORIGINAL FASTENERS. IF THE ORIGINAL FASTENER WAS RED-HEAD, THE REPLACEMENT FASTENER MUST BE RED-HEAD ALSO. CONTACT WAYNE DALTON FOR FASTENER STRENGTH VALUES IF NEEDED.

#### **WARNING**

**IMPACT GUNS ARE NOT RECOMMENDED. WHEN INSTALLING 5/16" LAG SCREWS USING AN ELECTRIC DRILL/ DRIVER, THE DRILL/ DRIVERS CLUTCH MUST BE SET TO DELIVER NO MORE THAN 200 IN-LBS OF TORQUE. FASTENER FAILURE COULD OCCUR AT HIGHER SETTINGS.**

**IMPORTANT:** RIGHT AND LEFT HAND IS DETERMINED INSIDE THE BUILDING LOOKING OUT.

Potential Hazard	Effect	Prevention
 <p>Moving door</p>	<p><b>WARNING</b></p> <p>Could result in Death or Serious Injury</p>	<p>Keep people clear of opening while Door is moving.</p> <p>Do <b>NOT</b> allow children to play with the Door Opener.</p> <p>Do <b>NOT</b> operate a Door that jams or one that has a broken spring.</p>
 <p>High tension spring</p>	<p><b>WARNING</b></p> <p>Could result in Death or Serious Injury</p>	<p>Do <b>NOT</b> try to remove, install, repair or adjust springs or anything to which door spring parts are fastened, such as, wood blocks, steel brackets, cables or other like items.</p> <p>Installations, repairs and adjustments must be done by a trained door system technician using proper tools and instructions.</p>

## Removing an Existing Door and Preparing the Opening

**IMPORTANT:** COUNTERBALANCE SPRING TENSION MUST ALWAYS BE RELEASED BEFORE ANY ATTEMPT IS MADE TO START REMOVING AN EXISTING DOOR.

#### **WARNING**

**A POWERFUL SPRING RELEASING ITS ENERGY SUDDENLY CAN CAUSE SEVERE OR FATAL INJURY. TO AVOID INJURY, HAVE A TRAINED DOOR SYSTEMS TECHNICIAN, USING PROPER TOOLS AND INSTRUCTIONS, RELEASE THE SPRING TENSION.**

To avoid possible injury and to insure proper installation, it's highly recommended that you read and fully understand the complete instructions on removing an Existing Door & Preparing the Opening. These are available for download at [www.Wayne-Dalton.com](http://www.Wayne-Dalton.com) or at your local Wayne Dalton Sales Center.

#### **WEATHERSTRIPS (MAY NOT BE INCLUDED):**

Depending on the size of your door, you may have to cut or trim the weatherstrips (if necessary) to properly fit into the header and jambs.

**NOTE:** If nailing product at 40°F or below, pre-drilling is required.

**NOTE:** Do not permanently attach weatherstrips to the header and jambs at this time.

**FOR QUICK INSTALL TRACK:** For the header, align the weatherstrip with the inside edge of the header and temporarily secure it to the header with equally spaced nails. Starting at either side of the jamb, fit the weatherstrip up tight against the temporarily attached weatherstrip in the header and flush with the inside edge of the jamb. Temporarily secure the weatherstrip with equally spaced nails. Repeat for other side. This will keep the bottom section from falling out of the opening during installation. Equally space nails approximately 12" to 18" apart.

**FOR FULLY ADJUSTABLE TRACK:** For the header, align the weatherstrip 1/8" to 1/4" inside the header edge, and temporarily secure it to the header with equally spaced nails. Starting at either side of the jamb, fit the weatherstrip up tight against the temporarily attached weatherstrip in the header and 1/8" to 1/4" inside the jamb edge. Temporarily secure the

weatherstrip with equally spaced nails. Repeat for other side. This will keep the bottom section from falling out of the opening during installation. Equally space nails approximately 12" to 18" apart.

# BREAKDOWN OF PARTS

**NOTE:** The illustrations shown on this page are general representations of the door parts. Each specific door models may have unique variations.

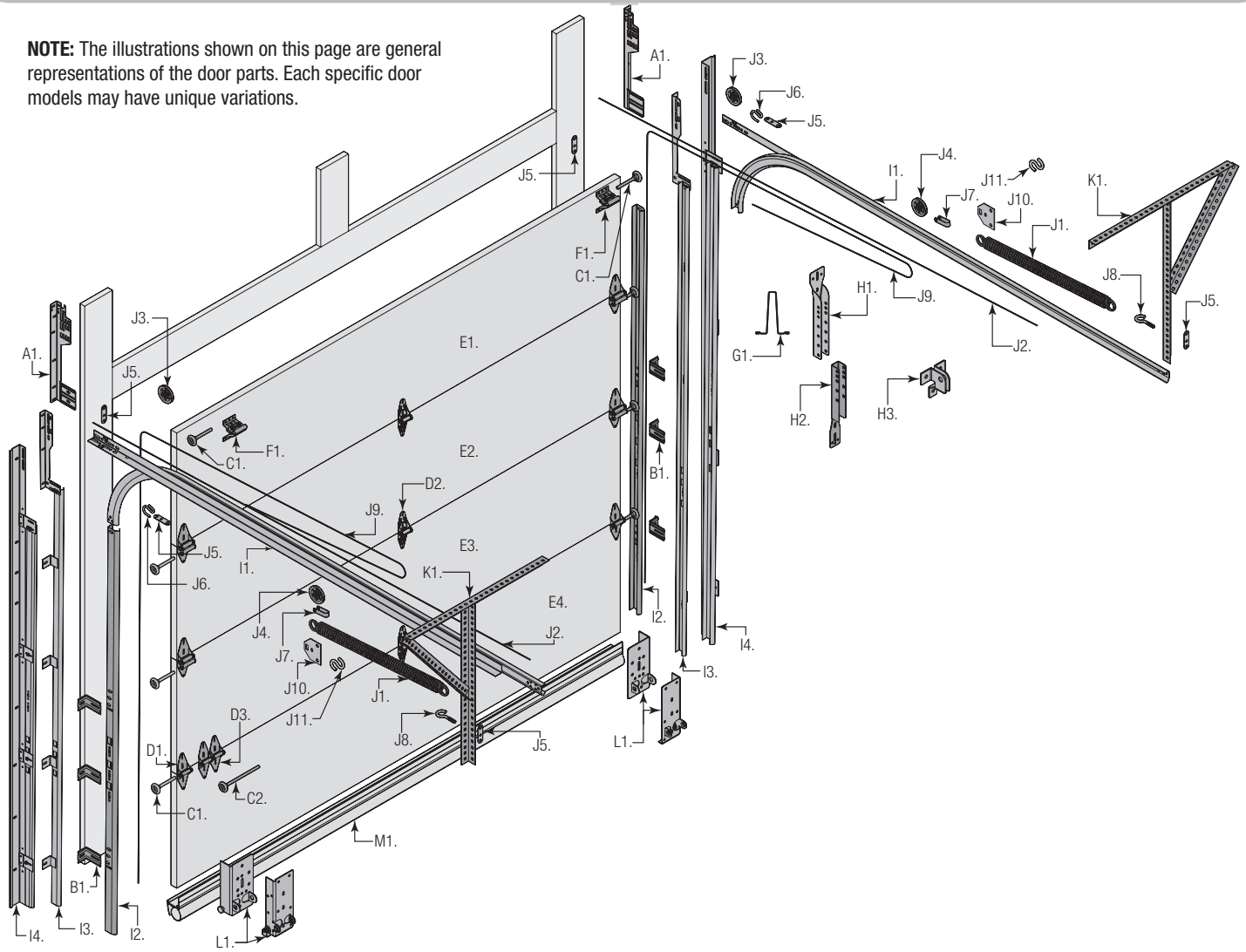

**A. FLAG ANGLES (AS REQUIRED):**

A1. Fully Adjustable (F.A.) Flag Angles

**B. JAMB BRACKETS (AS REQUIRED):**

B1. Fully Adjustable (F.A.) Jamb Brackets

**C. TRACK ROLLERS:**

C1. Short Stem Track Rollers

C2. Long Stem Track Rollers

**D. GRADUATED END HINGES (AS REQUIRED):**

D1. Single Graduated End Hinges (S.E.H.), Industry Standard

D2. Single Graduated Center Hinges (S.E.H.), Narrow Hinges

D3. Double Graduated End Hinges (D.E.H.), Industry Standard

**E. STACKED SECTIONS:**

E1. Top Section

E2. Intermediate(s) Section

E3. Lock Section

E4. Bottom Section

**F. TOP FIXTURES (AS REQUIRED):**

F1. Top Fixture Assemblies

**G. STRUT(S) (AS REQUIRED):**

G1. Strut (U - shaped)

**H. DRAWBAR OPERATOR BRACKET (FOR TROLLEY OPERATED DOORS):**

H1. Top Halve Drawbar Operator Bracket

H2. Bottom Halve Drawbar Operator Bracket

H3. Drawbar Operator Bracket (Supplied By Others)

**I. TRACKS (AS REQUIRED):**

I1. Left Hand and Right Hand Horizontal Track Assemblies

I2. Left Hand and Right Hand Vertical Tracks

I3. Left Hand and Right Hand Riveted Vertical Track Assemblies

I4. Left Hand and Right Hand Angle Mount Vertical Track Assemblies

**J. EXTENSION SPRING ASSEMBLY (AS REQUIRED):**

J1. Extension Springs

J2. Spring Restraint Cables

J3. Front Cable Lift Sheaves

J4. Rear Cable Lift Sheaves

J5. 3 Hole Clips (As Required)

J6. Small S-Hooks (As Required)

J7. Sheave Forks (As Required)

J8. 5/16" - 18 x 3-3/4" Eye Bolts (As Required)

J9. Counterbalance Lift Cables

J10. Hook Plates (As Required)

J11. Large S-Hooks (As Required)

**K. REAR BACK HANGS:**

K1. Left Hand And Right Hand Rear Back Hang Assemblies

**L. BOTTOM CORNER BRACKETS (AS REQUIRED):**

L1. Left Hand And Right Hand Bottom Corner Brackets

**M. BOTTOM WEATHER SEAL:**

M1. Bottom Weather Seal (Door Width)

# DOOR INSTALLATION INSTRUCTIONS

Before installing your door, be certain that you have read and followed all of the instructions covered in the pre-installation section of this manual. Failure to do so may result in an improperly installed door.

**NOTE:** Reference TDS 160 for general garage door terminology at [www.dasma.com](http://www.dasma.com).

**IMPORTANT:** IF THE DOOR WILL BE EXPOSED TO A SIGNIFICANT AMOUNT OF ROAD SALT, PAINT THE BARE GALVANIZED BOTTOM WEATHER STEEL RETAINER TO INHIBIT RUSTING.

## 1 Attaching Flag Angles and Jamb Brackets To Vertical Tracks

**NOTE:** If you have Riveted Track or Angle Mount Track, skip this step.

**FOR DOORS WITH FULLY ADJUSTABLE TRACK:** Hand tighten the left hand flag angle to the left hand vertical track using (2) 1/4" - 20 x 9/16" track bolts and (2) 1/4" - 20 flange hex nuts.

**NOTE:** The bottom jamb bracket is always the shortest bracket, while the center jamb bracket is the next tallest. If three jamb brackets per side are included with your door, you will have received a top jamb bracket, which is the tallest.

To attach the bottom jamb bracket, locate lower hole of the hole/ slot pattern of the 1st hole set on the vertical track. Align the slot in the jamb bracket with the lower hole of the hole/ slot pattern. Hand tighten jamb bracket using (1) 1/4" - 20 x 9/16" track bolt and (1) 1/4" - 20 flange hex nut.

Place the center jamb bracket over the lower hole of the hole/ slot pattern that is centered between the bottom jamb bracket and flag angle of the 2nd hole set. Hand tighten jamb bracket using (1) 1/4" - 20 x 9/16" track bolt and (1) 1/4" - 20 flange hex nut.

If a top jamb bracket was included, hand tighten it to vertical track using the lower hole of the hole/ slot pattern in the 3rd hole set and (1) 1/4" - 20 x 9/16" track bolt and (1) 1/4" - 20 flange hex nut.

## 2 Bottom Weather Seal

**NOTE:** Refer to door section identification, located in the pre-installation section of this manual or refer to Breakdown of Parts.

**NOTE:** Verify that the bottom weather seal is aligned with bottom section. If needed, trim the bottom weather seal even with bottom section length.

Position the bottom weather seal up against the bottom of the bottom section with the long lip on the inside surface of the bottom section. From inside the door, attach the bottom weather seal to the bottom section with 1/4" - 20 x 7/8" self drilling screws, placing one 6" in from each end of the bottom section and one every 18" (maximum) in between, as shown.

## 3 Attaching Bottom Corner Brackets

**NOTE:** Refer to door section identification, located in the pre-installation section of this manual or refer to Breakdown of Parts.

Uncoil the counterbalance lift cables.

**NOTE:** Refer to Package Contents / Breakdown of Parts, to determine which bottom corner brackets you have.

Depending on which bottom corner brackets you have (reference illustrations below), slip the loop at the ends of the counterbalance lift cable over the milford pin of the bottom corner bracket or secure the cable loop to the clevis pin and bottom corner bracket using a flat washer and a cotter pin. Repeat for other bottom corner bracket.

### WARNING

**ENSURE TIGHT FIT OF CABLE LOOP OVER PIN TO PREVENT COUNTERBALANCE LIFT CABLE FROM COMING OFF THE PIN, WHICH COULD ALLOW THE DOOR TO FALL AND RESULT IN SEVERE OR FATAL INJURY.**

Starting on the left hand side, attach the left hand bottom corner bracket to the left corner of the bottom section, making sure it is seated to the edges of the end cap, using (3) 1/4" - 14 x 7/8" RED HEAD self drilling screws, 1/4" - 14 x 7/8" self drilling screws. Insert a short stem track roller with roller spacer (if applicable) into the bottom corner bracket. Repeat for other side.

**IMPORTANT:** THE 1/4" - 14 X 7/8" RED HEAD SELF DRILLING SCREWS MUST BE MUST BE INSTALLED THROUGH THE HOLES OF THE BOTTOM CORNER BRACKETS, AS SHOWN.

**NOTE:** Check to ensure cable loop fits tightly over the milford pins.

**NOTE:** Verify bottom weather seal (bottom seal) is aligned with door section. If there is more than 1/2" excess bottom weather seal on either side, trim bottom weather seal even with door section.

## 4 Attaching Hinges

**NOTE:** Refer to door section identification, located in the pre-installation section of this manual to determine what size sections you need to use as your lock (second) section, intermediate (third) section, intermediate (fourth) section and top section. Measure your sections to make sure they are the correct height as indicated on the chart.

**NOTE:** The graduated end and center hinges can be identified by the number stamped on their lower hinge leaf.

**NOTE:** The #1, #2, #3, #4, graduated end hinges (Wide body) serves as end hinges on all sections, except for the top section.

**NOTE:** The #1 Center hinge(s) (Narrow body) serves as center hinges on all sections, except for the top section.

Starting on the left hand side of the bottom section, align the lower hinge leaf of the #1 graduated end hinge (wide body) over the holes, located at the top of the end caps. Align the lower hinge leaf of the #1 center hinges (narrow body) with the pre-marked locations at the center locations at the top of the section. Attach the lower hinge leaf to the section using (2) 1/4" - 14 x 7/8" self drilling screws.

**IMPORTANT:** ONCE THE 1/4" - 14 X 7/8" SELF DRILLING SCREWS ARE SNUG AGAINST THE LOWER HINGE LEAFS, TIGHTEN AN ADDITIONAL 1/4 TO 1/2 TURN TO RECEIVE MAXIMUM DESIGN HOLDING POWER.

Place a short stem track roller into each graduated end hinge. Repeat graduated hinge attachment using the appropriate graduated end hinges for all remaining sections except the top section.

**IMPORTANT:** WHEN PLACING SHORT STEM TRACK ROLLERS INTO THE #2 GRADUATED END HINGES AND HIGHER, THE SHORT STEM TRACK ROLLER GOES INTO HINGE TUBE FURTHER AWAY FROM SECTION.

**NOTE:** The #2 graduated end hinges serves as end hinges on the Lock section.

**NOTE:** The #3 graduated end hinges serves as end hinges on the Intermediate I section.

**NOTE:** The #4 graduated end hinges serves as end hinges on the Intermediate II section.

## 5 Attaching Top Fixtures To Top Section

**NOTE:** Refer to door section identification, located in the pre-installation section of this manual to determine what size sections you need to use as your top section.

**NOTE:** Refer to the strutting schedule below to determine the top section requires a strut. If your top section is not noted in the strutting schedule, it doesn't require a strut.

Top Section Strutting Schedule				
Section Quantity	Section Type	Solid / Windows	Door Widths	
			6'0" - 10'0"	12'0" - 18'0"
4 - 8	Top	Solid	-	2"
		Windows	2"	2"

Starting on the left hand side, align the top fixture base 3" down from the top section or below strut and even with the edge of the top section. The slotted half of the top fixture base should be facing upwards. Fasten to section through end cap using (4) 1/4" - 14 x 7/8" self drilling screws. Insert short stem track roller into top fixture slide. Repeat for other side.

**NOTE:** The top fixture slide will be tightened and adjusted later, in step, Adjusting Top Fixture.

**NOTE:** Ensure the top fixture slide is able to slide along the top fixture base. If needed, loosen the 1/4" - 20 flange hex nuts.

**IMPORTANT:** IF NO STRUT WAS INSTALLED ON THE TOP SECTION, PLACE (1) 1/4" - 14 X 7/8" SELF DRILLING SCREW INTO THE TOP PRE-PUNCHED HOLE IN EACH ENDSTILE OF THE TOP SECTION.

Place the strut on the top section, center the strut side to side on the top edge of the top section. Secure to the section using (2) 1/4" - 14 x 7/8" self drilling screws at each endstile and (2) 1/4" - 14 x 7/8" self drilling screw at each center hinge location at each pre-marked location.

## 6 Attaching Struts

**NOTE:** Depending on the size of your door, one or more sections may require a strut.

Using sawhorses, lay section on a flat smooth surface. Referring to the strutting schedule below, to determine how many struts your door needs and on what sections they are needed to be installed.

**NOTE:** Sections not noted in the strutting schedule, do not require a strut.

**Bottom, Lock, Intermediate(s) section Strutting Schedule**

Section Quantity	Section Type	Solid / Windows	Door Width		
			6'0" - 10'0"	12'0"	13'0" - 18'0"
4	Intermediate I	Solid	-	-	-
		Windows	2"	2"	-
	Lock	Solid	-	-	-
	Bottom	Solid	-	-	2"
5	Intermediate II	Solid	-	-	-
		Windows	2"	2"	-
	Intermediate I	Solid	-	-	2"
		Windows	2"	2"	2"
	Lock	Solid	-	-	-
	Bottom	Solid	-	-	2"

**NOTE:** All strut(s) are placed at the top of the section.

Place the strut on the section up against the bottom of the hinges. Center the strut side to side on the section as shown. Secure to the section using (2) 1/4" - 14 x 7/8" self drilling screws at each end hinge location and (2) 1/4" - 14 x 7/8" self drilling screw at each center hinge location.

## 7 Attaching Step Plate To Bottom Section

On the inside of the bottom section, locate the vertical center of the door. Center the inside step plate vertically no higher than 8" from the bottom of the door to the top of the step plate.

**IMPORTANT:** DO NOT MOUNT THE STEP PLATE HIGHER THAN 8" FROM THE BOTTOM OF THE SECTION.

Using the inside step plate's second top most hole and bottom hole as a template, drill 7/16" diameter holes through the entire section.

**IMPORTANT:** BE EXTREMELY CAREFUL TO KEEP DRILL STRAIGHT.

Now insert the outside step plate into the holes through the front of the door, mounting the two step plates back to back. Secure step plates together with two No. 8 screws through the inside step plate and into the outside step plate.

## 8 Attaching Lift Handles

Locate the vertical center of the lock (second) section of the door and position the lift handle's bottom hole 4" from the bottom of the lock section along the vertical center on the outside of the door. Use the holes in the lift handle as a template to mark the hole locations.

**IMPORTANT:** THE LIFT HANDLE AND THE STEP PLATE NEED TO BE VERTICALLY ALIGNED.

Drill 9/32" diameter holes through the section at each marked location. Enlarge the holes from outside the door to 1/2" diameter through the section. Assemble the outside and inside lift handles to the section using (2) 1/4" - 20 x 2-1/2" carriage bolts and (2) 1/4" - 20 hex nuts and spacers.

### **WARNING**

**TO AVOID POSSIBLE INJURY, LIFT HANDLES THAT ARE INSTALLED WITHIN 4 INCHES (102MM) OF A SECTION INTERFACE SHALL PROMOTE VERTICAL ORIENTATION OF THE HAND.**

## 9 Positioning Bottom Section

Center the bottom section in the door opening. Level the section using wooden shims (if necessary) under the bottom section. When the bottom section is leveled, temporarily hold it in place by driving a nail into the jamb and bending it over the edge of the bottom section on both sides.

## 10 Attaching Vertical Tracks To Jamb

**NOTE:** Depending on your door, you may have Quick Install Flag Angles, Fully Adjustable Flag Angles, Riveted Vertical Track Assemblies or you may have Angle Mount Vertical Track Assemblies. Refer to Package Contents / Breakdown of Parts, to determine which Flag Angles / Vertical Track Assemblies you have.

**IMPORTANT:** IF YOUR DOOR IS TO BE INSTALLED PRIOR TO A FINISHING CONSTRUCTION OF THE BUILDING'S FLOOR, THE VERTICAL TRACKS AND THE DOOR BOTTOM SECTION ASSEMBLY SHOULD BE INSTALLED SUCH THAT WHEN THE FLOOR IS CONSTRUCTED, NO DOOR OR TRACK PARTS ARE TRAPPED IN THE FLOOR CONSTRUCTION.

**IMPORTANT:** THE TOPS OF THE VERTICAL TRACKS MUST BE LEVEL FROM SIDE TO SIDE. IF THE BOTTOM SECTION WAS SHIMMED TO LEVEL IT, THE VERTICAL TRACK ON THE SHIMMED SIDE MUST BE RAISED THE HEIGHT OF THE SHIM.

**NOTE:** Make sure the counterbalance lift cable is located between the track rollers and the door jamb.

Starting on the left hand side of the bottom section, remove the nail. Position the left hand vertical track assembly over the track rollers of the bottom section and install, as shown. Drill 3/16" pilot holes into the door jamb for the lag screws.

**FOR QUICK INSTALL FLAG ANGLES OR FULLY ADJUSTABLE FLAG ANGLES:** Loosely fasten jamb brackets and flag angle to the jamb using 5/16" x 1-5/8" lag screws. Tighten lag screws, securing the bottom jamb bracket to jamb, maintain 3/8" to 5/8" spacing, between the bottom section and vertical track. Hang counterbalance lift cable over flag angle. Repeat same process for other side.

**FOR RIVETED VERTICAL TRACK ASSEMBLY:** Loosely fasten jamb brackets and flag angle to the jamb using 5/16" x 1-5/8" lag screws. Tighten lag screws, securing the bottom jamb bracket to jamb, maintain 3/8" to 5/8" spacing as shown between the bottom section and vertical track. Hang counterbalance lift cable over flag angle. Repeat same process for other side.

**FOR ANGLE MOUNT VERTICAL TRACK ASSEMBLY:** Loosely fasten the slots in the wall angle to the jamb using 5/16" x 1-5/8" lag screws. Tighten lag screws, securing the bottom slot in the wall angle, maintain 3/8" to 5/8" spacing as shown between the bottom section and vertical track. Hang counterbalance lift cable over angle mount. Repeat same process for other side.

## 11 Stacking Sections

**NOTE:** Refer to door section identification, located in the pre-installation section of this manual to determine what size sections you need to use as your lock (second) section, intermediate (third) section, intermediate (fourth) section, intermediate (fifth) section, intermediate (sixth) section and intermediate (seventh) section. Measure your sections to make sure they are the correct height as indicated on the chart.

**NOTE:** Make sure graduated end and center hinges are flipped down, when stacking another section on top.

With assistance, lift second section and guide the track rollers into the vertical tracks. Lower section until it is seated against bottom section. Flip hinges up. Fasten center hinge(s) first; then end hinges last using 1/4" - 14 x 7/8" self drilling screws.

Repeat same process for other sections, except top section.

**IMPORTANT:** PUSH & HOLD THE HINGE LEAFS SECURELY AGAINST THE SECTIONS WHILE SECURING WITH 1/4" - 14 X 7/8" SELF DRILLING SCREWS. THERE SHOULD BE NO GAP BETWEEN THE HINGE LEAFS AND THE SECTIONS.

**NOTE:** Install lock at this time (sold separately). See optional installation step, Side Lock.

## 12 Stacking Top Section

Place the top section in the opening. Install a nail to prevent the top section from falling backwards. Now, flip up the hinge leaves, hold tight against section, and fasten center hinges first and end hinges last (refer to step, Stacking Sections). Vertical track alignment is critical. Position flag angle or wall angle between 1-11/16" (43 mm) to 1-3/4" (44 mm) from the edge of the door; tighten the bottom lag screw. Flag angles must be parallel to the door sections. Repeat for other side.

**IMPORTANT:** THE DIMENSION BETWEEN THE FLAG ANGLES OR WALL ANGLES MUST BE DOOR WIDTH PLUS 3-3/8" (86MM) TO 3-1/2" (89 MM) FOR SMOOTH, SAFE DOOR OPERATION.

**FOR QUICK INSTALL TRACK:** Complete the vertical track installation by securing the jamb bracket(s) and tightening the other lag screws. Repeat for other side.

**FOR FULLY ADJUSTABLE TRACK OR RIVETED TRACK:** Complete the vertical track installation by securing the jamb bracket(s) and tightening the other lag screws. Push the vertical track against the track rollers so that the track rollers are touching the deepest part of the curved side of the track; tighten all the track bolts and nuts. Repeat for other side.

**FOR ANGLE MOUNT TRACK:** Complete the vertical track installation by securing the jamb bracket(s) and or tightening the other lag screws. Push the vertical track against the track rollers so that the track rollers are touching the deepest part of the curved side of the vertical track, as shown. Repeat for other side.

## 13 Attaching Drawbar Operator Bracket

**IMPORTANT:** WHEN CONNECTING A TROLLEY TYPE GARAGE DOOR OPENER TO THIS DOOR, A WAYNE DALTON OPERATOR/ TROLLEY BRACKET MUST BE SECURELY ATTACHED TO THE TOP SECTION OF THE DOOR IF ONE HAS BEEN PROVIDED, ALONG WITH ANY STRUTS PROVIDED WITH THE DOOR (IF A WAYNE DALTON OPERATOR/ TROLLEY BRACKET WAS NOT PROVIDED WITH YOUR DOOR, THEN USE THE ONE PROVIDED BY YOUR OPERATOR MANUFACTURER). THE INSTALLATION OF THE OPERATOR MUST BE ACCORDING TO MANUFACTURER'S INSTRUCTIONS AND FORCE SETTINGS MUST BE ADJUSTED PROPERLY.

**NOTE:** For retro fit applications, the drawbar operator bracket must be aligned with an existing operator.

**NOTE:** Refer to illustrations to determine which drawbar operator bracket were supplied with your door. Follow the corresponding step below:

Place the bottom half inside the top half and flush against the inside surface of the top section. Adjust both the top and bottom halves out as far apart as possible on the section surface. Secure the drawbar operator bracket bottom half and the top half together using (4) 5/16" - 18 x 1/2" carriage bolts and (4) 5/16" - 18 flange hex nuts.

**NOTE:** Install the 5/16" - 18 x 1/2" carriage bolts and the 5/16" - 18 flange hex nuts as far apart as possible, prior to securing both top and bottom halves together.

Now, locate the center of the top section and align the center of the holes in the drawbar operator bracket assembly vertically.

**NOTE:** For retro fit applications, the drawbar operator bracket assembly must be aligned with an existing operator.

Slide the top half of the drawbar operator bracket assembly under the strut, keeping the drawbar operator bracket assembly aligned with the center line. Remove the strut's screws, if necessary and attach to the top section (through strut if necessary) using (3) 1/4" - 20 x 7/8" self drilling screws.

**NOTE:** If your door lacks a strut on the top section, ignore the previous paragraph.

Attach the bottom half of the drawbar operator bracket to the section surface using (3) 1/4" - 20 x 7/8" self drilling screws.

**NOTE:** When attaching drawbar operator bracket to top section with strut, apply additional pressure to thread into the strut.

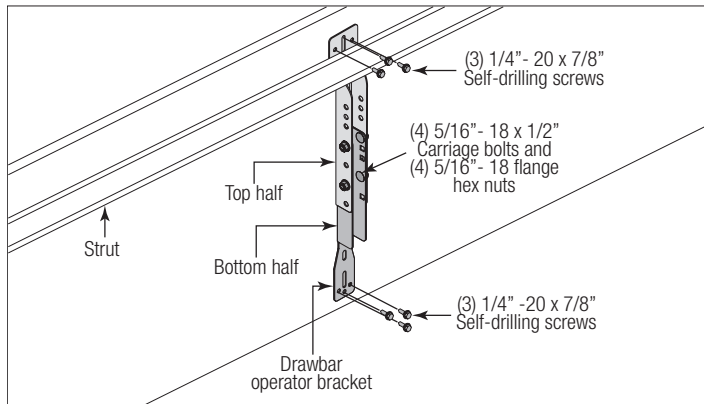

Locate the center of the top section. Position the drawbar operator bracket under the strut (if applicable) or align the drawbar operator bracket top edge with the top edge of the top section, as shown. Attach the drawbar operator bracket using (3) 1/4" - 20 x 7/8" self-drilling screws (as shown).

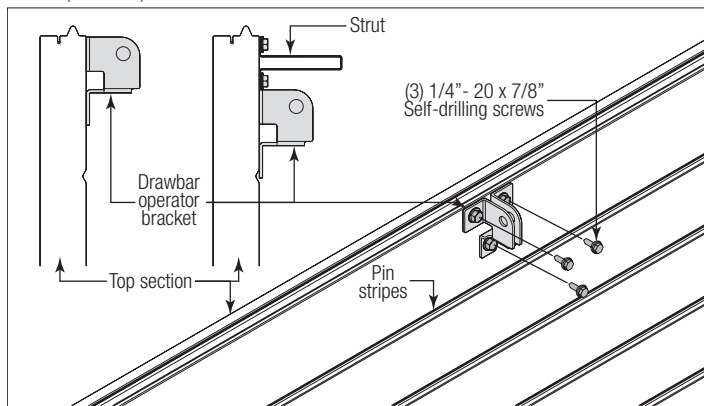

## 14 Attaching Horizontal Tracks

**NOTE:** Depending on your door, you may have Quick Install Flag Angles, Fully Adjustable Flag Angles, Riveted Vertical Track Assemblies or you may have Angle Mount Vertical Track Assemblies. Refer to Package Contents / Breakdown of Parts, to determine which Flag Angles / Vertical Track Assemblies you have.

### ⚠ WARNING

**DO NOT RAISE DOOR UNTIL HORIZONTAL TRACKS ARE SECURED AT REAR, AS OUTLINED IN STEP, REAR BACK HANGS, OR DOOR COULD FALL FROM OVERHEAD POSITION CAUSING SEVERE OR FATAL INJURY.**

**IF YOU HAVE QUICK INSTALL FLAG ANGLES:** To install horizontal track, place the curved end over the top track roller of the top section. Align key slot of the horizontal track with the Quick Install tab of the flag angle. Push curved portion of horizontal track down to lock in place.

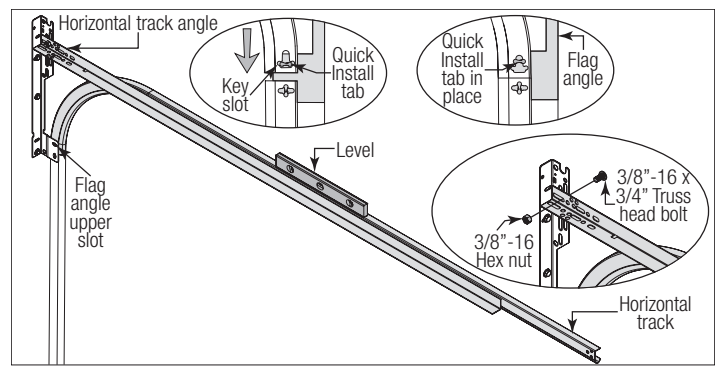

**FOR OTHER FLAG ANGLES:** To install horizontal track, place the curved end over the top track roller of the top section. Align the bottom of the horizontal track with the top of the vertical track. Tighten the horizontal track to the flag angle with (2) 1/4" - 20 x 9/16" track bolts and (2) 1/4" - 20 flange hex nuts.

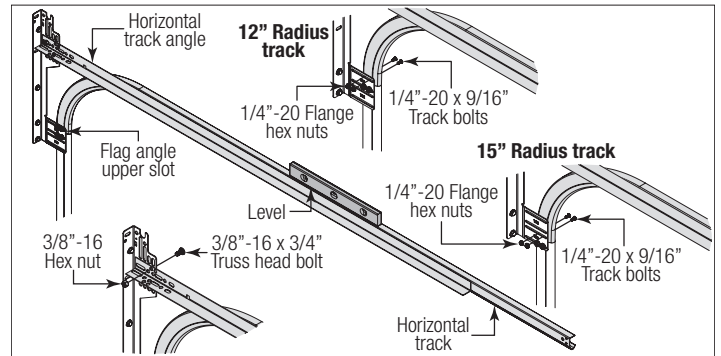

**IF YOU HAVE ANGLE MOUNT:** To install horizontal track, place the curved end over the top track roller of the top section. Align the bottom of the horizontal track with the top of the vertical track. Tighten the horizontal track to the angle mount with (2) 1/4" - 20 x 9/16" track bolts and (2) 1/4" - 20 flange hex nuts.

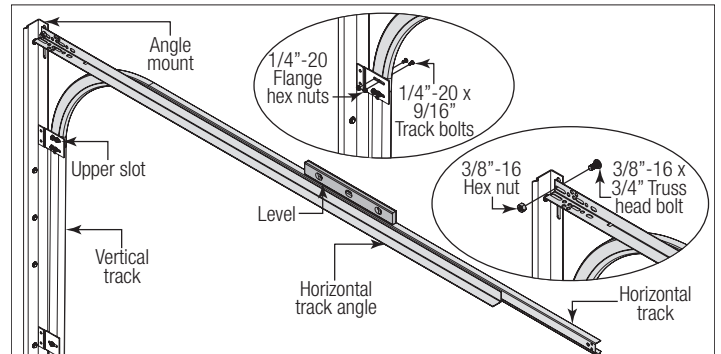

Next level the horizontal track assembly and bolt the horizontal track angle to the first encountered slot in the flag angle / angle mount using (1) 3/8" - 16 x 3/4" truss head bolt and (1) 3/8" - 16 hex nut. Repeat for other side. Remove nail that was temporarily holding the top section in position.

**IMPORTANT:** FAILURE TO REMOVE NAIL BEFORE ATTEMPTING TO RAISE DOOR COULD CAUSE PERMANENT DAMAGE TO TOP SECTION.

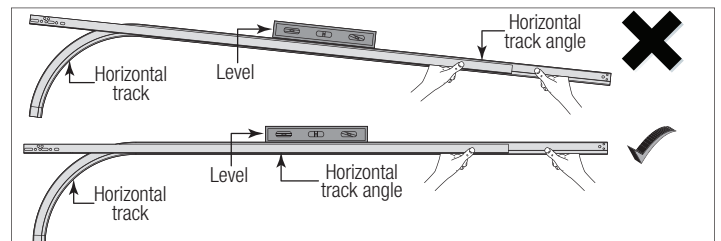

## 15 Adjusting Top Fixtures

With horizontal tracks installed, you can now adjust the top fixtures. Vertically align the top section of the door with the lower sections. Once aligned, position the top fixture slide, out against the horizontal track. Maintaining the slide's position, tighten the (2) 1/4" - 20 flange hex nuts to secure the top fixture slide to the top fixture base. Repeat for other side.

# COUNTERBALANCE INSTALLATION INSTRUCTIONS

## 16 Attaching Rear Back Hangs

Raise the door until the top section and half of the next section are in the horizontal track radius. Do not raise door any further since rear of horizontal tracks are not yet supported.

### WARNING

**RAISING DOOR INTO THE LOOSE HORIZONTAL TRACKS CAN RESULT IN DOOR FALLING AND CAUSE SEVERE OR FATAL INJURY.**

Clamp a pair of locking pliers onto the vertical tracks just above the second track roller on one side, and just below the second track roller on the other side. This will prevent the door from raising or lowering while installing the rear back hangs.

Using the chart below, select the appropriate perforated angle (may not be supplied). Fabricate and install rear back hangs, as shown.

**NOTE:** If an opener is installed, position horizontal tracks one hole above level when securing them to the rear back hangs.

**Perforated Angle Gauge Weight Limitations For Extension Springs:**

Perforated Angle Gauge	Door Balance Weight
1-1/4" x 1-1/4" x 15 Gauge	220 lbs. to 440 lbs.
1-1/4" x 1-1/4" x 16 Gauge	175 lbs. to 350 lbs.

### WARNING

**MAKE SURE BACK HANGS ARE BRACED SUFFICIENTLY TO RESIST ANY MOTION DURING SPRING APPLICATION AND DOOR TRAVEL. IF BACK HANGS PIVOT OR DEFLECT, ADD REINFORCEMENT UNTIL THEY REMAIN FIRM AND STATIONARY. ANY BACK HANG THAT HAS BENT MUST BE REPLACED.**

### WARNING

**KEEP HORIZONTAL TRACKS PARALLEL AND WITHIN 3/4" TO 7/8" FROM DOOR EDGE, OTHERWISE DOOR COULD FALL, RESULTING IN SEVERE OR FATAL INJURY.**

**IMPORTANT:** DO NOT SUPPORT THE WEIGHT OF THE DOOR ON ANY PART OF THE REAR BACK HANGS THAT CANTILEVER 4" OR MORE BEYOND A SOUND FRAMING MEMBER.

**NOTE:** If rear back hangs are to be installed over drywall, use (2) 5/16" x 2" hex head lag screws and make sure lag screws engage into solid structural lumber.

### WARNING

**FAILURE TO ASSEMBLE AND ATTACH REAR BACK HANGS PROPERLY ACCORDING TO THE ABOVE INSTRUCTIONS MAY RESULT IN DOOR FALLING WHEN RAISED, CAUSING SEVERE OR FATAL INJURY.**

**NOTE:** Perforated angle must be attached to sound framing members and **nails should not be used.**

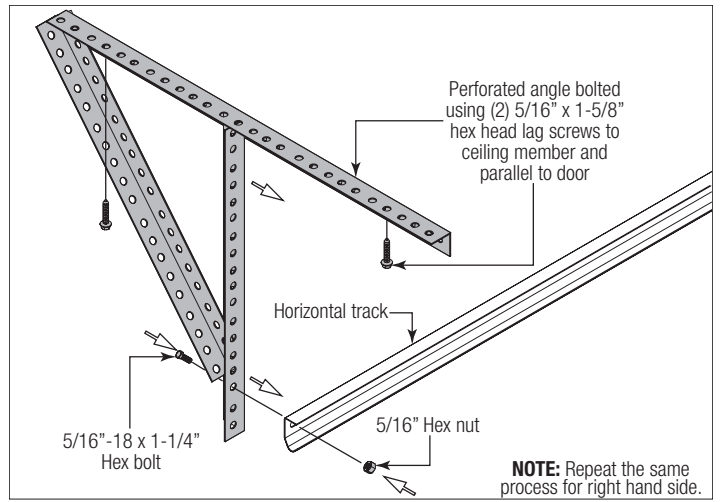
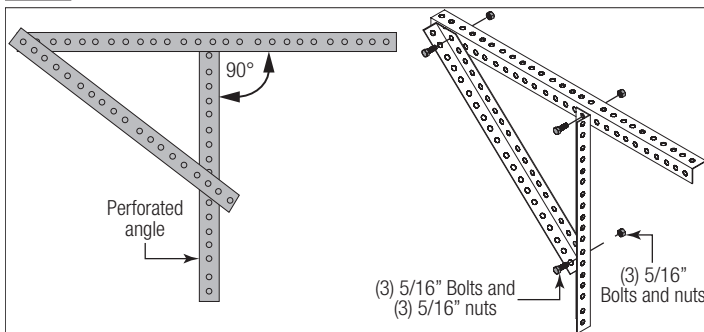

**NOTE:** Repeat the same process for right hand side.

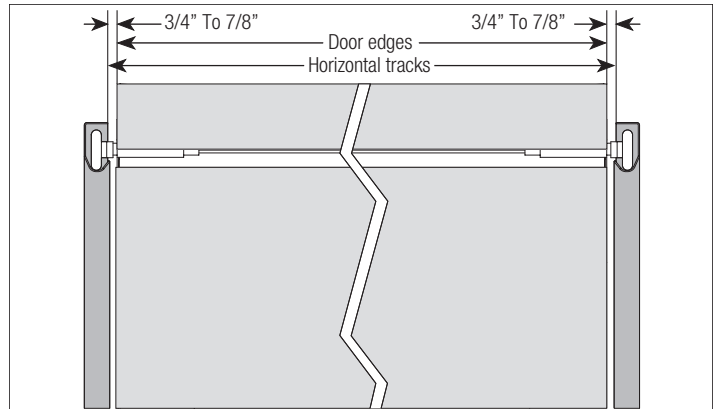

## 17 Attaching Front Cable Lift Sheaves

**IF YOU HAVE 3" FRONT CABLE LIFT SHEAVE AND A 12" RADIUS HORIZONTAL TRACK:** Starting on the left hand side and using (1) 3/8" - 16 hex nut, secure the front cable lift sheave to the 13/32" hole near the top of the flag angle, as shown.

**IF YOU HAVE 3" OR 4" FRONT CABLE LIFT SHEAVE AND A 15" RADIUS HORIZONTAL TRACK:** Starting on the left hand side and using (1) 3/8" - 16 hex nut, secure the front cable lift sheave to the first 13/32" hole in the horizontal angle, as shown.

Repeat the same process for the right hand side.

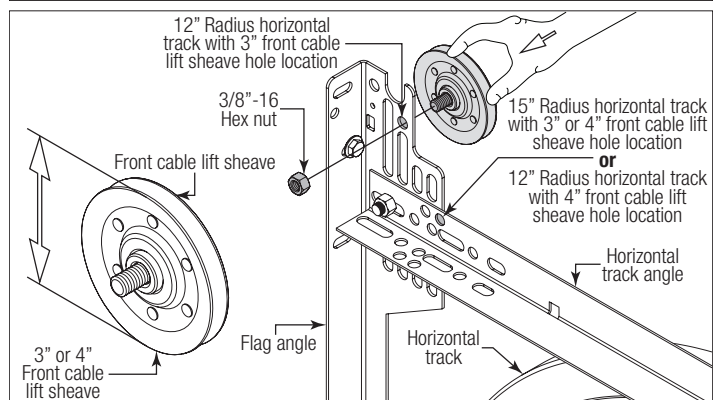
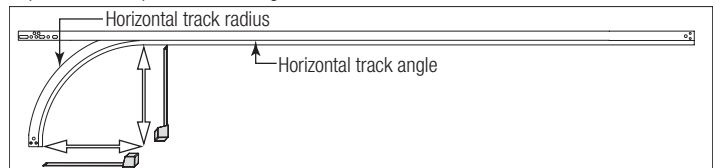

## 18 Attaching Extension Springs

Remove the locking pliers from the vertical tracks.



# WARNING

WITH ASSISTANCE, RAISE THE DOOR SLOWLY INTO THE OPEN POSITION MAKING SURE THE DOOR TRAVELS SMOOTHLY THROUGH THE TRACKS. CLAMP LOCKING PLIERS TO THE BACK LEG OF BOTH HORIZONTAL TRACKS, BELOW THE BOTTOM TRACK ROLLERS TO KEEP THE DOOR FROM LOWERING.

**NOTE:** This illustration shows the outside of the door in the open position.

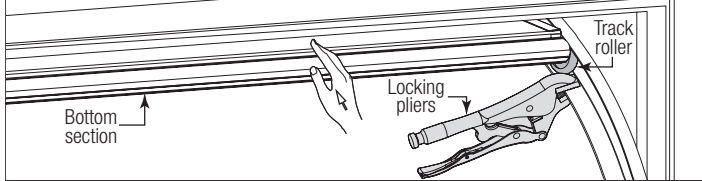

# WARNING

FAILURE TO INSTALL SPRING RESTRAINT CABLES CAN RESULT IN SEVERE OR FATAL INJURY IN CASE OF SPRING BREAKAGE.

Position (1) 5/16" - 18 x 3-3/4" eye bolt and (1) 5/16" - 18 hex nut into the rear back hang, 6" to 8" above the horizontal track, as shown. Feed the spring safety cable through the rear back hang and tie the special knot around the "room side" of the 3 hole clip, as shown. Secure the eye bolt and 3 hole clip to the rear back hang using (1) 5/16" - 18 hex nut. Hook one end of the extension spring onto the eye bolt. Feed the spring safety cable through the rear extension spring loop and center of the extension spring then front spring loop, pull the spring safety cable taut and tie the special knot around the "jamb side" of the 3 hole clip. Attach the "jamb side" 3 hole clip to the jamb near the flag angle using (1) 5/16" x 1-5/8" lag bolt. Repeat the same process for the other side.

**NOTE:** Some larger doors feature 2 pairs of extension springs. A spring restraint cable must be installed through each spring.

**IMPORTANT:** SPRING RESTRAINT CABLES MUST BE TAUT AND EQUALIZED.

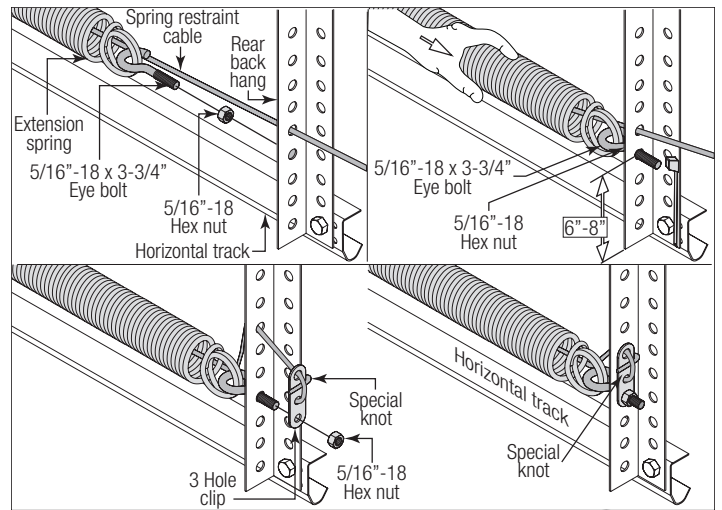
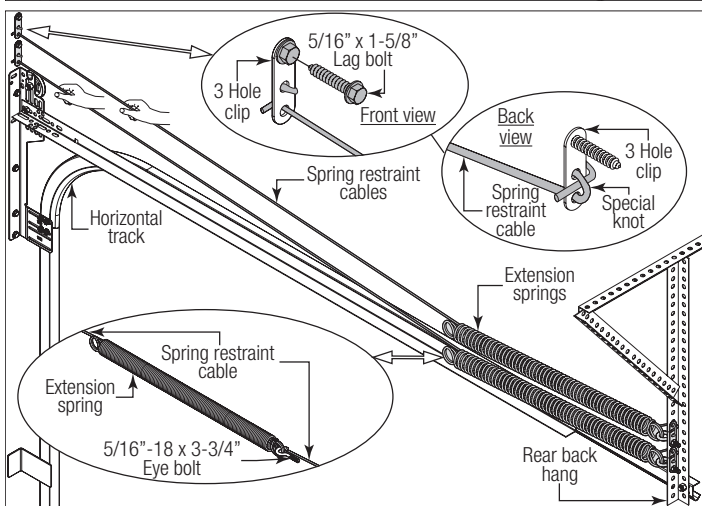
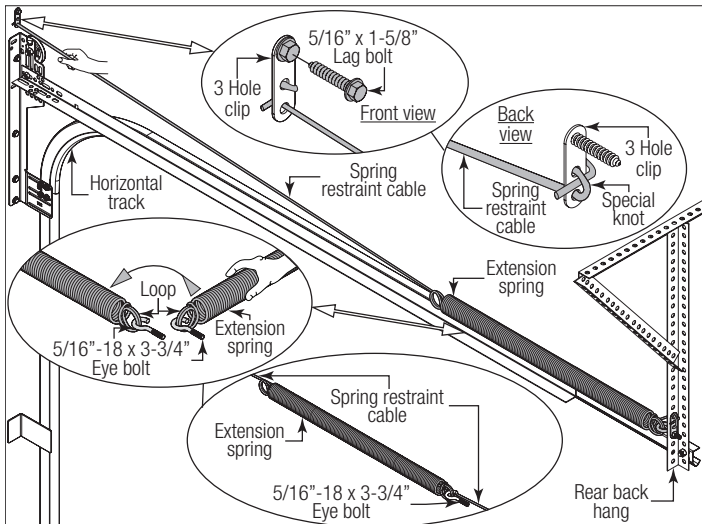

## 19

### Attaching Spring Sheaves

**IF YOU HAVE ONE PAIR OF EXTENSION SPRINGS:** Hook the sheave fork through the front loop of the extension spring and attach the sheave fork to the rear cable lift sheave using (1) 3/8" - 16 x 1-1/4" hex head bolt and (1) 3/8" - 16 hex nut. Thread the counterbalance lift cable over the front cable lift sheave and around the rear cable lift sheave and tie the special knot around the "horizontal angle" using a 3 hole clip, as shown. Insert one end of the small "S" hook into the "horizontal angle" with the 3 hole clip and the other end into the second slot of the horizontal angle, as shown. Repeat for the other side.

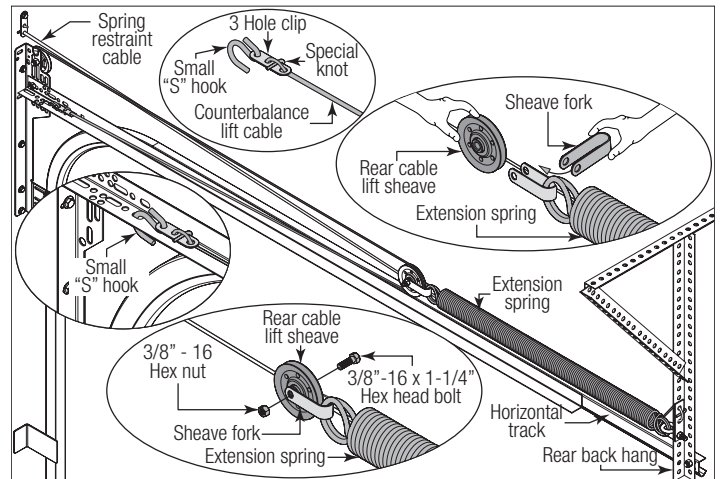

**NOTE:** Some larger doors feature 2 pairs of extension springs. A spring restraint cable must be installed through each spring.

**IF YOU HAVE TWO PAIR OF EXTENSION SPRINGS:** Insert two large "S" hooks and the sheave fork into the hook plate. Attach the sheave fork to the rear cable lift sheave using (1) 3/8" - 16 x 1-1/4" hex head bolt and (1) 3/8" - 16 hex nut. Thread the counterbalance lift cable over the front cable lift sheave and around the rear cable lift sheave and tie the special knot around the "horizontal angle" using a 3 hole clip, as shown. Insert one end of the small "S" hook into the "horizontal angle" with the 3 hole clip and the other end into the second slot of the horizontal angle, as shown. Repeat for the other side.

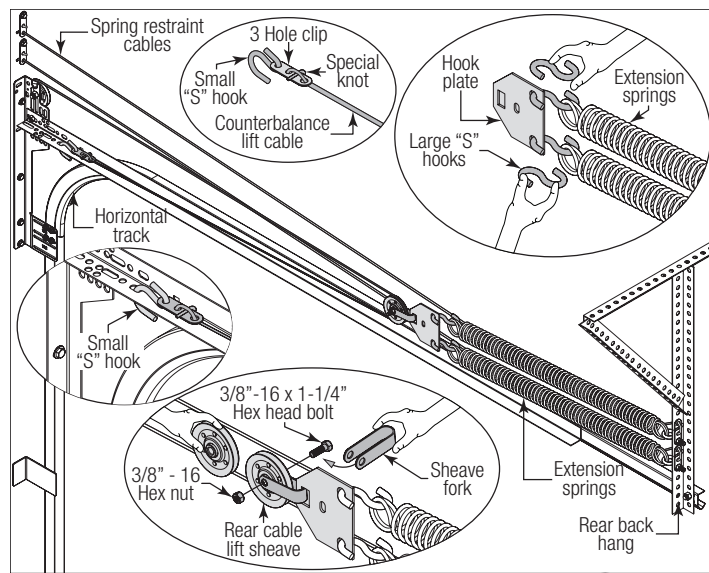

**IMPORTANT:** CLOSE "S" HOOKS AND EYE BOLTS WITH LOCKING PLIERS, TO PREVENT SPRINGS FROM COMING LOOSE.

## WARNING

**FAILURE TO CLOSE "S" HOOKS AND EYE BOLTS CAN RESULT IN SEVERE OR FATAL INJURY IF SPRINGS COME LOOSE.**

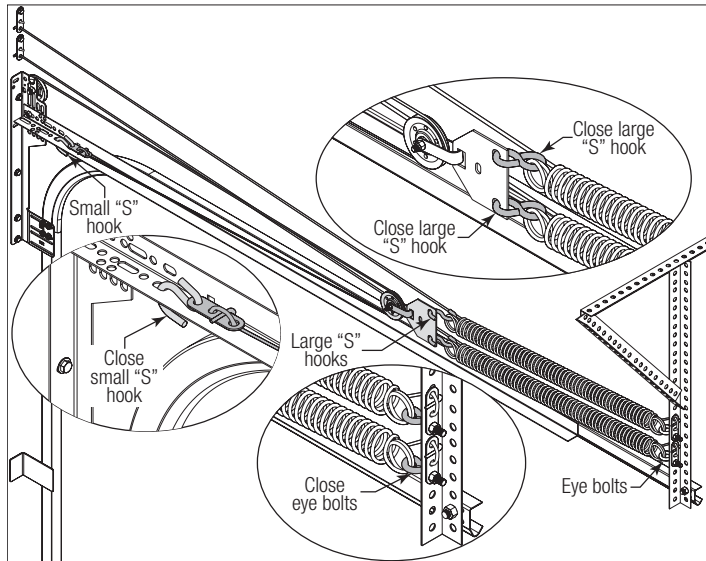

## 20 Counterbalance Lift Cable Adjustments

Adjust counterbalance lift cables to create about 1" to 2" (25 mm to 50 mm) of initial extension spring stretch, with the door in the fully opened position. Measure relaxed extension spring length for your door height and verify with the chart below. Spring length must be the same for both extension springs to allow even door balance. Carefully remove the locking pliers from the horizontal track and lower the door into the closed position. Once the door is closed, measure the extension spring length in tension for both sides. Using the chart, verify the spring length in tension is correct with your door height.

**NOTE:** It may be necessary to adjust spring length for proper door balance.

Door Height	Spring Length Relaxed (Door Open)	Spring Length Extended (Door Closed)
6' 0"	25" (635 mm)	61" (1549 mm)
6' 3"	25" (635 mm)	62-1/2" (1588 mm)
6' 6"	25" (635 mm)	64" (1626 mm)
7' 0"	25" (635 mm)	67" (1702 mm)
7' 6"	27" (686 mm)	72" (1829 mm)
7' 9"	27" (686 mm)	73-1/2" (1867 mm)

Door Height	Spring Length Relaxed (Door Open)	Spring Length Extended (Door Closed)
8' 0"	27" (686 mm)	75" (1905 mm)

## 21 Balancing Door

Lift door and check its balance. If door rises off floor more than 2 ft. under spring tension alone, reduce spring tension by adjusting extension spring length, moving the "S" hook backward (towards the rear back hangs) to a different hole in the horizontal track. If the door is hard to rise or drifts down on its own, adjust extension spring length by moving the "S" hook forward (towards the header) to a different hole in the horizontal track. A poorly balanced door can cause garage door operator problems.

**IMPORTANT:** WHENEVER ADJUSTING EXTENSION SPRING LENGTH FOR DOOR BALANCE, ALWAYS OPEN THE DOOR TO THE FULLY OPEN POSITION AND RETURN THE LOCKING PLIERS, AS SHOWN IN F3 TO THE HORIZONTAL TRACKS BELOW THE BOTTOM TRACK ROLLERS.

If the door still does not operate easily, raise the door into the open position, return the locking pliers, and recheck the following items:

- 1.) Is the door level?
- 2.) Are the flag angles level and plumb?
- 3.) Does the distance between the flag angles equal door width plus 3-3/8" to 3-1/2"?
- 4.) Do the counterbalance lift cables have equal tension? Adjust by re-tying the special knot, if necessary.
- 5.) Make sure door is not rubbing on jambs.

**IMPORTANT:** IF DOOR STILL DOES NOT BALANCE PROPERLY, THEN CONTACT A TRAINED DOOR SYSTEM TECHNICIAN.

## 22 Attaching Weather Seal

Permanently attach the weatherstrips on both door jambs and header. The weatherstrips were temporarily attached in Preparing the Opening, in the pre-installation section of this manual.

**NOTE:** When permanently attaching the weatherstrips to the jambs, avoid pushing the weatherstrips too tightly against the face of door.

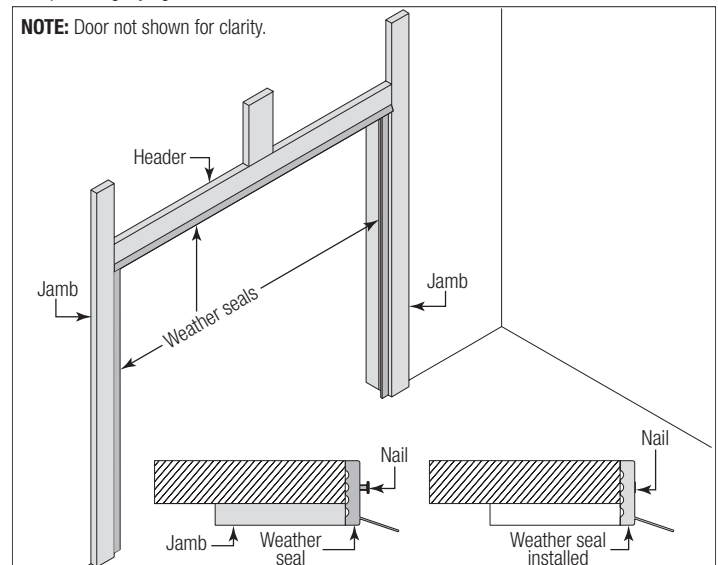

## 23 Label Placement

**IMPORTANT:** USING THE ILLUSTRATION, ATTACH THE APPROPRIATE LABELS TO THE APPROPRIATE LOCATION ON THE SECTION, AS SHOWN.

**NOTE:** The Spring Warning tag(s) are factory attached (one per spring).

**NOTE:** Because of different configurations, some labels may require minor relocations.

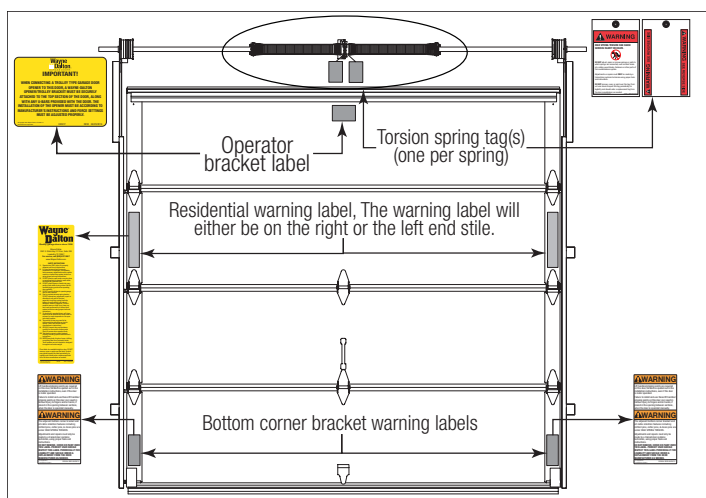

## MAINTENANCE

### Cleaning Your Garage Door

Like any other exterior surface, Wayne Dalton garage doors will have dirt exposure from atmospheric conditions. Ordinarily, the cleaning action of rainfall will be adequate to wash the door, or the door can be washed periodically by hosing with a garden hose and clear water (in particular) for the areas not accessible to rain. If you desire to do a more thorough cleaning, or where soil collection conditions occur, follow these simple instructions.

1. Use a soft-bristled, long-handled washing brush. It attaches to your garden hose and makes washing your garage door easier. Do not rub vigorously which may create glossy areas over the vinyl finish.
2. For hard-to-remove dirt, such as soot and grime found in industrial areas, wash the garage door down with a mild solution consisting of the following ingredients:

One cup detergent (with less than 0.5% phosphate) dissolved into five gallons of warm water.

**NOTE:** The use of detergents containing greater than 0.5% phosphate is not recommended for use in general cleaning of garage doors.

**NOTE:** Be sure to clean behind weather stripping on both sides and top of door.

3. Start at the bottom and work up to the top, as less streaking will result. Immediately following all washing operations, thoroughly rinse the surface area with fresh water from a garden hose.

This cleaning and maintenance information is suggested in an effort to be of assistance; however, manufacturer cannot assume responsibility for results obtained which are dependent on the cleaning solution and method of application.

### CAUTION

DO NOT PAINT DOOR. PAINTING DOOR WILL VOID YOUR WARRANTY.

### Operation And Maintenance

**OPERATING YOUR GARAGE DOOR:** Before you begin, read all warning labels affixed to the door and the installation instructions and owner's manual. When correctly installed, your Wayne Dalton door will operate smoothly. Always operate your door with controlled movements. Do not slam your door or throw your door into the open position, this may cause damage to the door or its components. If your door has an electric opener, refer to the owner's manual to disconnect the opener before performing manual door operation below.

**MANUAL DOOR OPERATION:** For additional information on manual garage door operations go to [www.dasma.com](http://www.dasma.com) and reference TDS 165.

### WARNING

DO NOT PLACE FINGERS OR HANDS INTO SECTION JOINTS WHEN OPENING AND/OR CLOSING A DOOR. ALWAYS USE LIFT HANDLES / SUITABLE GRIPPING POINTS WHEN OPERATING THE DOOR MANUALLY.

**OPENING A DOOR:** Make sure the lock(s) are in the unlocked position. Lift the door by using the lift handles / suitable gripping points only. Door should open with little resistance.

**CLOSING A DOOR:** From inside the garage, pull door downward using lift handles / gripping point only. If you are unable to reach the lift handles/ suitable gripping points only, use pull down rope affixed to the side of door. Door should close completely with little resistance.

### USING AN ELECTRIC OPERATOR:

**IMPORTANT:** PULL DOWN ROPES MUST BE REMOVED AND LOCKS MUST BE REMOVED OR MADE INOPERATIVE IN THE UNLOCKED POSITION.

When connecting a drawbar (trolley type) garage door operator to this door, a drawbar operator bracket must be securely attached to the top section of the door, along with any struts provided with the door. Always use the drawbar operator bracket supplied with the door. To avoid possible damage to your door, Wayne Dalton recommends reinforcing the top section with a strut (may or may not be supplied). The installation of the drawbar operator must be according to manufacturer's instructions and force settings must be adjusted properly. Refer to the owner's manual supplied with your drawbar operator for complete details on installation, operation, maintenance and testing of the operator.

**MAINTAINING YOUR GARAGE DOOR:** Before you begin, read all warning labels affixed to the door and the installation instructions and owner's manual. Perform routine maintenance steps once a month, and have the door professionally inspected once a year. Review your Installation Instructions and Owner's Manual for the garage door. These instructions are available at no charge from Wayne Dalton, a division of Overhead Door Corporation, P.O. Box 67, Mt. Hope, OH., 44660, or at [www.Wayne-Dalton.com](http://www.Wayne-Dalton.com). For additional information on garage door/operator maintenance go to [www.dasma.com](http://www.dasma.com) and reference TDS 151, 167 and 179.

### Monthly Inspections:

**1. Visual Inspection:** Closely inspect jambs, header and mounting surface. Any material found not to be structurally sound must be replaced. It may be necessary to uninstall part or all of the door assembly in order to replace defective material. Refer to the supplemental instructions "Removing an Existing Door / Preparing the Opening" at [www.Wayne-Dalton.com](http://www.Wayne-Dalton.com). Inspect the spring(s), counterbalance lift cables, track rollers, pulleys, rear back hangs and other door hardware for signs of worn or broken parts. Tighten any loose screws and/or bolts, except on bottom corner brackets or on the counterbalance assembly. Check exterior surface of the door sections for any minor cracks. Verify door has not shifted right or left in the opening. If you suspect problems, contact a trained door system technician.

### WARNING

**GARAGE DOOR SPRINGS, COUNTERBALANCE LIFT CABLES, BRACKETS, AND OTHER HARDWARE ATTACHED TO THE SPRINGS ARE UNDER EXTREME TENSION, AND IF HANDLED IMPROPERLY, CAN CAUSE SEVERE OR FATAL INJURY. ONLY A TRAINED DOOR SYSTEMS TECHNICIAN SHOULD ADJUST THEM, BY CAREFULLY FOLLOWING THE MANUFACTURER'S INSTRUCTIONS.**

### WARNING

**NEVER REMOVE, ADJUST, OR LOOSEN THE BOLTS, SCREWS AND/OR LAG SCREWS ON THE COUNTERBALANCE (END BEARING BRACKETS, DRUMS OR SPRING SYSTEM) OR BOTTOM CORNER BRACKETS OF THE DOOR. THESE BRACKETS ARE CONNECTED TO THE SPRING(S) AND ARE UNDER EXTREME TENSION. TO AVOID POSSIBLE SEVERE OR FATAL INJURY, HAVE ANY SUCH WORK PERFORMED BY A TRAINED DOOR SYSTEMS TECHNICIAN USING PROPER TOOLS AND INSTRUCTIONS.**

**TORQUEMASTER® PLUS SPRINGS:** Pawl knob(s) (located on the TorqueMaster® end brackets above the door) should be engaged to prevent the door from rapidly descending in case of spring failure or forceful manual operation.

**EXTENSION SPRINGS:** A restraining cable or other device should be installed on the extension spring (located above the horizontal tracks) to help contain the spring if it breaks.

**2. Door Balance:** Periodically test the balance of your door. If you have a garage door drawbar operator, use the release mechanism so you can operate the door by hand when doing this test. Start with the door in the fully closed position. Using handles or suitable gripping points, lift the door to check its balance. Adjust TorqueMaster® or Extension spring(s), if door lifts by itself (hard to pull down) or if door is difficult to lift (easy to pull down). DO NOT attempt to repair or adjust Torsion Springs yourself. To adjust TorqueMaster® or Extension spring(s), refer to your installation instructions and owner's manual. If in question about any of the procedures, do not perform the work. Instead, have it adjusted by a trained door systems technician.

**3. Lubrication:** The door should open and close smoothly. Ensure the door track rollers are rotating freely when opening and closing the door. If track rollers do not rotate freely, clean the door tracks, removing dirt and any foreign substances. Clean and lubricate (use a non-silicon based lubricant) graduated end hinges, center hinges, steel track rollers, bearings and torsion springs (torsion spring coil surfaces). DO NOT lubricate plastic idler bearings, nylon track rollers, door track. DO NOT oil a cylinder lock, if actuation is difficult use a graphite dust to lubricate.

**CHECK FOR PRESENCE OF SAFETY LABELS:**

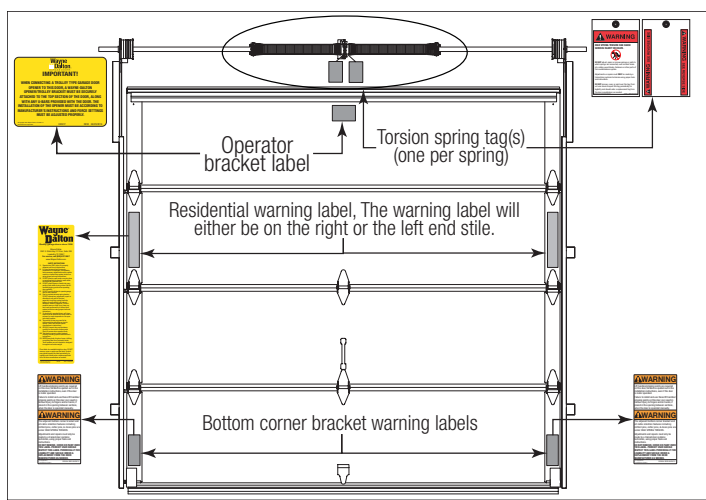

within the applicable warranty period, and in writing to the authorized distributor or installer whose name and address appear below. The purchaser must allow Seller a reasonable opportunity to inspect any Product claimed to be defective prior to removal or any alteration of its condition. Proof of the purchase and/or installation date, and identification as the original purchaser, may be required. There are no established informal dispute resolution procedures of the type described in the Magnuson-Moss Warranty Act.

• SELLER: \_\_\_\_\_

• SELLER'S ADDRESS: \_\_\_\_\_

\_\_\_\_\_

## WARRANTY

### Limited Warranty

#### Model 8700

Wayne Dalton, a division of Overhead Door Corporation ("Seller") warrants to the original purchaser of the Model 8700 ("Product"), subject to all of the terms and conditions hereof, that the Product and all components thereof will be free from defects in materials and workmanship for the following period(s) of time, measured from the date of installation:

- **FIFTEEN (15) YEARS** - Against peeling flaking, chipping or cracking of the vinyl skin.
- **FIVE (5) YEARS** - Against excessive color fading of the vinyl skin, not due to normal weathering, which materially alters the color of the Product and cannot be remedied by cleaning with the recommended solution
- **ONE (1) YEAR** - All other components of the Product

Seller's obligation under this warranty is specifically limited to repairing or replacing, at its option, any part which is determined by Seller to be defective during the applicable warranty period. Any labor charges are excluded and will be the responsibility of the purchaser.

This warranty gives you specific legal rights, and you may also have other rights which vary from state to state. This warranty is made to the original purchaser of the Product only, and is not transferable or assignable. This warranty applies only to Product installed in a residential or other non-commercial application. It does not cover any Product installed in commercial or industrial building applications. This warranty does not apply to any unauthorized alteration or repair of the Product, or to any Product or component which has been damaged or deteriorated due to misuse, neglect, accident, failure to provide necessary maintenance, improper installation of hardware, puncture, normal wear and tear, or acts of God or any other cause beyond the reasonable control of Seller. This warranty specifically excludes any damage resulting from scratching, abrasion or impact by any hard object or exposure to toxic or abrasive environments including toxic chemicals or fumes, and any fading or color change which may not be uniform due to unequal exposure of the curtains to sunlight or other elements. The Product is not recommended for use in hot, dry climates. This warranty specifically excludes coverage for any Product used or installed in Utah, Arizona, Nevada, New Mexico, Colorado and the West and Southwest regions of Texas. The Limited Warranty for the sections of the door will be voided if sections are painted.

ALL EXPRESS AND IMPLIED WARRANTIES FOR THE PRODUCT, INCLUDING BUT NOT LIMITED TO ANY IMPLIED WARRANTIES OF MERCHANTABILITY AND FITNESS FOR A PARTICULAR PURPOSE, ARE LIMITED IN TIME TO THE APPLICABLE WARRANTY PERIOD REFLECTED ABOVE. NO WARRANTIES, WHETHER EXPRESS OR IMPLIED, WILL APPLY AFTER THE LIMITED WARRANTY PERIOD HAS EXPIRED. Some states do not allow limitations on how long an implied warranty lasts, so the above limitation may not apply to you.

IN NO EVENT SHALL SELLER BE RESPONSIBLE FOR, OR LIABLE TO ANYONE FOR, SPECIAL, INDIRECT, COLLATERAL, PUNITIVE, INCIDENTAL OR CONSEQUENTIAL DAMAGES, even if Seller has been advised of the possibility of such damages. Such excluded damages include, but are not limited to, loss of use, cost of any substitute product, or other similar indirect financial loss. Some states do not allow the exclusion or limitation of incidental or consequential damages, so the above limitation or exclusion may not apply to you.

Claims under this warranty must be made promptly after discovery,



---

Thank you for your purchase.

---

**PLEASE DO NOT RETURN THIS PRODUCT TO THE STORE**

If you need assistance, please call 1-866-569-3799 (press Option 1) and follow the prompts to contact a customer service representative. They will be happy to handle any questions that you may have.

---

After installation is complete, leave this Installation Instructions And Owner's Manual with the homeowner, or fasten it near garage door for easy reference.