

8000/8100/8200

TORQUEMASTER[®] PLUS

STANDARD LIFT

MH
QUICK START GUIDE

Table Of Contents

Pre-Installation	2
Important Safety Instructions	2
Removing an Existing Door	2
Preparing the Opening	2
Parts Breakdown	3
Installation	4
Maintenance	11
Cleaning Your Garage Door	11
Painting Your Garage Door	11
Maintaining The Finish On Your Garage Door	11
Operation And Maintenance	11
Warranty	12

PLEASE DO NOT RETURN THIS PRODUCT TO THE STORE

Please Do Not Return This Product To The Store. Please call 1-866-569-3799 (Press Option 1) and follow the prompts to contact the appropriate customer service agent. They will be happy to handle any questions that you may have.

QUICK START GUIDE IMPORTANT NOTICES!

This Quick Start Guide is only meant to be used as an aid and / or introduction to garage door installation, and does not replace the complete Installation Instructions and Owner's manual available on the web at www.WayneDalton.com. Wayne Dalton highly recommends that you read and fully understand the Installation Instructions and Owner's Manual before you attempt this installation.

To avoid possible injury, read the enclosed instructions carefully before installing and operating the garage door. Pay close attention to all warnings and notes. After installation is complete, fasten this manual near garage door for easy reference.

DEFINITION OF DOOR HEIGHTS:

1. Door Heights less than or equal to 8'0" ($\leq 8'0"$) are considered Standard Lift Applications.

The complete Installation Instructions and Owner's Manual are available at no charge from:

Wayne Dalton, a Division Of Overhead Door Corporation,
P.O. Box 67, Mt. Hope, OH., 44660, Or Online At www.Wayne-Dalton.com

Important Safety Instructions

DEFINITION OF KEY WORDS USED IN THIS MANUAL:

WARNING

INDICATES A POTENTIALLY HAZARDOUS SITUATION WHICH, IF NOT AVOIDED, COULD RESULT IN SEVERE OR FATAL INJURY.

 **CAUTION:** PROPERTY DAMAGE OR INJURY CAN RESULT FROM FAILURE TO FOLLOW INSTRUCTIONS.

IMPORTANT: REQUIRED STEP FOR SAFE AND PROPER DOOR OPERATION.

NOTE: Information assuring proper installation of the door.

READ THESE INSTRUCTIONS CAREFULLY BEFORE ATTEMPTING INSTALLATION. IF IN QUESTION ABOUT ANY OF THE PROCEDURES, DO NOT PERFORM THE WORK. INSTEAD, HAVE A TRAINED DOOR SYSTEMS TECHNICIAN DO THE INSTALLATION OR REPAIRS.

- 1. READ AND FOLLOW ALL INSTALLATION INSTRUCTIONS.**
- Wear protective gloves during installation to avoid possible cuts from sharp metal edges.
- It is always recommended to wear eye protection when using tools, otherwise eye injury could result.
- Avoid installing your new door on windy days. Door could fall during the installation causing severe or fatal injury.
- Doors 12'-0" wide and over should be installed by two persons, to avoid possible injury.
- Operate door only when it is properly adjusted and free from obstructions.
- If a door becomes hard to operate, inoperative or is damaged, immediately have necessary adjustments and/ or repairs made by a trained door system technician using proper tools and instructions.
- DO NOT stand or walk under a moving door, or permit anybody to stand or walk under an electrically operated door.
- DO NOT place fingers or hands into open section joints when closing a door. Use lift handles/ gripping points when operating door manually.
- DO NOT permit children to operate garage door or door controls. Severe or fatal injury could result should the child become entrapped between the door and the floor.
- Due to constant extreme spring tension, do not attempt any adjustment, repair or alteration to any part of the door, especially to springs, spring brackets, bottom corner brackets, fasteners, counterbalance lift cables or supports. To avoid possible severe or fatal injury, have any such work performed by a trained door systems technician using proper tools and instructions.
- On electrically operated doors, pull down ropes must be removed and locks must be removed or made inoperative in the open (unlocked) position.
- Top section of door may need to be reinforced when attaching an electric opener. Check door and/ or opener manufacturer's instructions.
- Visually inspect door and hardware monthly for worn and or broken parts. Check to ensure door operates freely.
- Test electric opener's safety features monthly, following opener manufacturer's instructions.
- NEVER hang tools, bicycles, hoses, clothing or anything else from horizontal tracks. Track systems are not intended or designed to support extra weight.
- This door may not meet the building code wind load requirements in your area. For your safety, you will need to check with your local building official for wind load code requirements and building permit information.

After installation is complete, fasten this manual near the garage door.

IMPORTANT: STAINLESS STEEL OR PT2000 COATED LAG SCREWS MUST BE USED WHEN INSTALLING CENTER BEARING BRACKETS, END BRACKETS, JAMB BRACKETS, DRAWBAR OPERATOR MOUNTING/ SUPPORT BRACKETS AND DISCONNECT BRACKETS ON TREATED LUMBER (PRESERVATIVE-TREATED). STAINLESS STEEL OR PT2000 LAG SCREWS ARE NOT NECESSARY WHEN INSTALLING PRODUCTS ON UN-TREATED LUMBER.

NOTE: It is recommended that 5/16" lag screws are pilot drilled using a 3/16" drill bit, prior to fastening.

IMPORTANT: WHEN INSTALLING 5/16" LAG SCREWS USING AN ELECTRIC DRILL/ DRIVER, THE DRILL/ DRIVERS CLUTCH MUST BE SET TO DELIVER NO MORE THAN 200 IN-LBS OF TORQUE. FASTENER FAILURE COULD OCCUR AT HIGHER SETTINGS.

WARNING

PRIOR TO WINDING OR MAKING ADJUSTMENTS TO THE SPRINGS, ENSURE YOU'RE WINDING IN THE PROPER DIRECTION AS STATED IN THE INSTALLATION INSTRUCTIONS. OTHERWISE, THE SPRING FITTINGS MAY RELEASE FROM SPRING IF NOT WOUND IN THE PROPER DIRECTION AND COULD RESULT IN SEVERE OR FATAL INJURY.

IMPORTANT: RIGHT AND LEFT HAND IS ALWAYS DETERMINED FROM INSIDE THE BUILDING LOOKING OUT

Removing an Existing Door

IMPORTANT: COUNTERBALANCE SPRING TENSION MUST ALWAYS BE RELEASED BEFORE ANY ATTEMPT IS MADE TO START REMOVING AN EXISTING DOOR.

WARNING

A POWERFUL SPRING RELEASING ITS ENERGY SUDDENLY CAN CAUSE SEVERE OR FATAL INJURY. TO AVOID INJURY, HAVE A TRAINED DOOR SYSTEMS TECHNICIAN, USING PROPER TOOLS AND INSTRUCTIONS, RELEASE THE SPRING TENSION.

For detailed information see supplemental instructions "Removing an Existing Door / Preparing the Opening". These instructions are not supplied with the door, but are available at no charge from Wayne Dalton, A Division Of Overhead Door Corporation, P.O. Box 67, Mt. Hope, OH., 44660, or at www.Wayne-Dalton.com.

Preparing the Opening

WEATHERSTRIPS (MAY NOT BE INCLUDED):

Depending on the size of your door, you may have to cut or trim the weatherstrips (if necessary) to properly fit into the header and jambs.

NOTE: If nailing product at 40°F or below, pre-drilling is required.

NOTE: Do not permanently attach weatherstrips to the header and jambs at this time.

For Quick Install track: For the header, align the weatherstrip with the inside edge of the header and temporarily secure it to the header with equally spaced nails. Starting at either side of the jamb, fit the weatherstrip up tight against the temporarily attached weatherstrip in the header and flush with the inside edge of the jamb. Temporarily secure the weatherstrip with equally spaced nails. Repeat for other side. This will keep the bottom section from falling out of the opening during installation. Equally space nails approximately 12" to 18" apart.

For other track systems: For the header, align the weatherstrip 1/8" to 1/4" inside the header edge, and temporarily secure it to the header with equally spaced nails. Starting at either side of the jamb, fit the weatherstrip up tight against the temporarily attached weatherstrip in the header and 1/8" to 1/4" inside the jamb edge. Temporarily secure the weatherstrip with equally spaced nails. Repeat for other side. This will keep the bottom section from falling out of the opening during installation. Equally space nails approximately 12" to 18" apart.

PARTS BREAKDOWN

NOTE: The illustrations shown on this page are general representations of the door parts. Each specific door models may have unique variations.

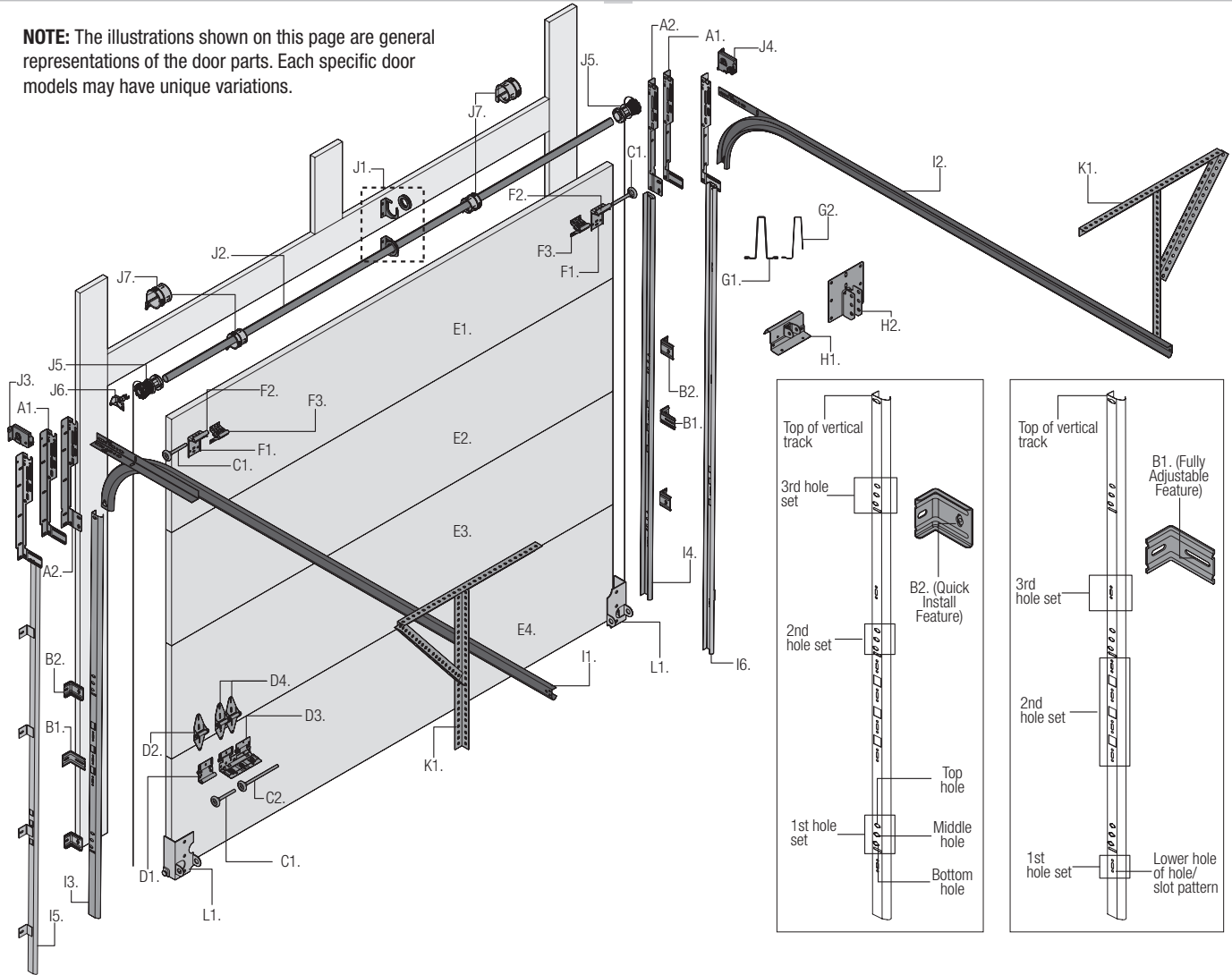

A. FLAG ANGLES (AS REQUIRED):

- A1. Fully Adjustable (F.A.) Flag Angles
- A2. Quick Install (Q.I.) Flag Angles

B. JAMB BRACKETS (AS REQUIRED):

- B1. Fully Adjustable (F.A.) Jamb Brackets
- B2. Quick Install (Q.I.) Jamb Brackets

C. TRACK ROLLERS:

- C1. Short Stem Track Rollers
- C2. Long Stem Track Rollers

D. GRADUATED END HINGES:

- D1. Single Graduated End Hinges (S.E.H.), Anti-Pinch
- D2. Single Graduated End Hinges (S.E.H.), Industry Standard
- D3. Double Graduated End Hinges (D.E.H.), Anti-Pinch
- D4. Double Graduated End Hinges (D.E.H.), Industry Standard

E. STACKED SECTIONS:

- E1. Top Section
- E2. Intermediate(s) Section
- E3. Lock Section
- E4. Bottom Section

F. TOP FIXTURES (AS REQUIRED):

- F1. Top Fixture Bases
- F2. Top Fixture Slides
- F3. Top Fixture Assemblies

G. STRUT(S) (AS REQUIRED):

- G1. Strut (U-shaped)
- G2. Strut (A-symmetrical)

H. DRAWBAR OPERATOR BRACKET (FOR TROLLEY OPERATED DOORS):

- H1. Drawbar Operator Bracket – For Models 9600/9400/9100/5140/5120
- H2. Drawbar Operator Bracket – For Models 9700/9800

I. TRACKS:

- I1. Left Hand Horizontal Track Assembly
- I2. Right Hand Horizontal Track Assembly
- I3. Left Hand Vertical Track
- I4. Right Hand Vertical Track
- I5. Left Hand Riveted Vertical Track Assembly
- I6. Right Hand Riveted Vertical Track Assembly

J. TORQUEMASTER PLUS® SPRING ASSEMBLY:

- J1. Center Bracket Bushing Assembly
- J2. TorqueMaster® Spring Tube (Single Or Double Springs)
- J3. Left Hand End Bracket (Double Springs Only)
- J4. Right Hand End Bracket (Disconnect Cable Guide)
- J5. Left Hand And Right Hand Cable Drum Assemblies
- J6. Idler bracket (Single Spring Only)
- J7. Left Hand And Right Hand Drum Wraps (Optional)

K. REAR BACK HANGS:

- K1. Left Hand And Right Hand Rear Back Hang Assemblies

L. BOTTOM CORNER BRACKETS (AS REQUIRED):

- L1. Left Hand And Right Hand Bottom Corner Brackets

INSTALLATION

Before installing your door, be certain that you have read and followed all of the instructions covered in the pre-installation section of this manual. Failure to do so may result in an improperly installed door.

NOTE: Reference TDS 160 for general garage door terminology at www.dasma.com.

1

Quick Install Flag Angles

Tools Required: Safety glasses, Leather gloves

NOTE: If you have Fully Adjustable Flag Angles, Riveted Track or Angle Mount Track, skip this step.

NOTE: Flag angles are right and left handed.

Place the lower Quick Install tab of the left hand flag angle in the Quick Install feature of the left hand vertical track. Give the flag angle 1/4 turn to lock in place. Repeat for other side.

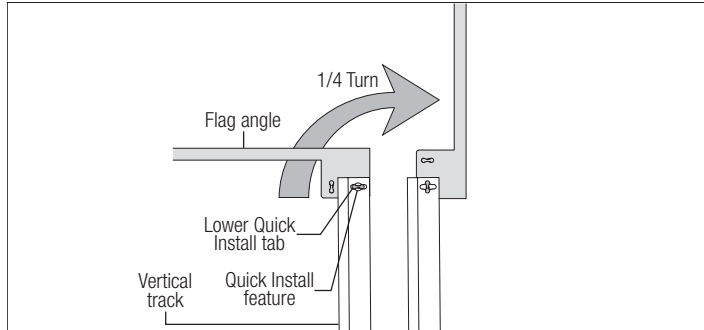

2

Fully Adjustable Flag Angles

Tools Required: Safety glasses, Leather gloves

NOTE: If you have Quick Install flag angles, Riveted Track or Angle Mount Track, skip this step.

NOTE: Flag angles are right and left handed.

If you have Quick Install vertical tracks, hand tighten the left hand flag angle to the left hand vertical track using (1) stud plate and (2) 1/4" - 20 flange hex nuts. Repeat for the other side.

If you have Fully Adjustable vertical tracks, hand tighten the left hand flag angle to the left hand vertical track using (2) 1/4" - 20 x 9/16" track bolts and (2) 1/4" - 20 flange hex nuts. Repeat for other side. Flange nuts will be secured after flag angle spacing is completed in step, Top Section.

3

Horizontal Track Angles

Tools Required: Hammer, Safety glasses, Leather gloves

NOTE: For larger doors, a full length horizontal track angle may not already be spot welded to the horizontal track. If the horizontal track angle is not welded, the horizontal track angle will be installed, as shown.

Position the left hand horizontal track angle, as shown. Place the Quick Install tabs of the horizontal track angle in the key slot of the left hand horizontal track. Using a hammer, tap the horizontal track angle towards the curved end of the track until the alignment hole in the track and angle are aligned. Repeat for other side. Set tracks aside.

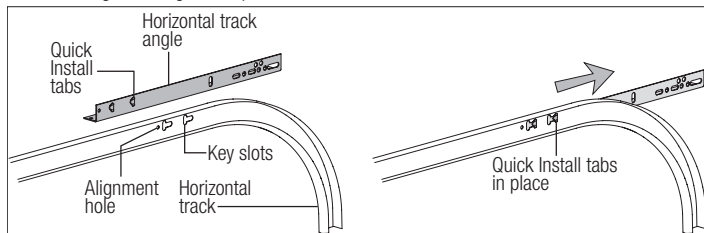

4

Quick Install Jamb Brackets

Tools Required: Tape measure, Safety glasses, Leather gloves

NOTE: If you have Fully Adjustable jamb brackets, Riveted Track or Angle Mount Track, skip this step.

Measure the length of the vertical tracks. Using the jamb bracket schedule, determine the placement of the jamb brackets for your door height and track length. To install the jamb brackets, align the Quick Install tab on the Quick Install jamb bracket with the Quick Install feature in the vertical track and turn the bracket perpendicular to the track so the mounting

flange is toward the back (flat) leg of the track. Repeat for other side.

JAMB BRACKET SCHEDULE

DOOR HEIGHT	TRACK LENGTH	1ST SET		2ND SET		3RD SET	
6'0"	64" (1626 mm)	9	M	11	M	NA	
6'3"	67" (1702 mm)	9	B	11	M	NA	
6'6"	70" (1778 mm)	9	M	10	B	NA	
6'9"	73" (1854 mm)	9	M	10	B	NA	
7'0"	76" (1930 mm)	9	M	10	B	NA	
7'6"	82" (2083 mm)	9	T	10	M	11	M
7'9"	85" (2159 mm)	9	T	10	M	11	M
8'0"	88"	9	T	10	M	11	M

B= BOTTOM HOLE, M= MIDDLE HOLE, T= TOP HOLE

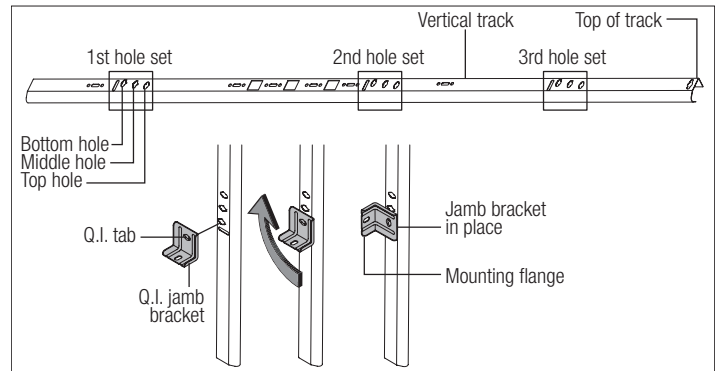

5

Fully Adjustable Jamb Brackets

Tools Required: Tape measure, Safety glasses, Leather gloves

NOTE: If you have Quick Install jamb brackets, Riveted Track or Angle Mount Track, skip this step.

NOTE: The bottom jamb bracket is always the shortest bracket, while the center jamb bracket is the next tallest. If three jamb brackets per side are included with your door, you will have received a top jamb bracket, which is the tallest.

To attach the bottom jamb bracket, locate lower hole of the hole/ slot pattern of the 1st hole set on the vertical track. Align the slot in the jamb bracket with the lower hole of the hole/ slot pattern. Secure jamb bracket using (1) 1/4" - 20 x 9/16" track bolt and (1) 1/4" - 20 flange hex nut. Repeat for other side.

Place the center jamb bracket over the lower hole of the hole/ slot pattern that is centered between the bottom jamb bracket and flag angle of the 2nd hole set. Secure jamb bracket using (1) 1/4" - 20 x 9/16" track bolt and (1) 1/4" - 20 flange hex nut. Repeat for other side.

If a top jamb bracket was included, secure it to vertical track using the lower hole of the hole/ slot pattern in the 3rd hole set and (1) 1/4" - 20 x 9/16" track bolt and (1) 1/4" - 20 flange hex nut. Repeat for other side.

6

Graduated Hinge Attachment

Tools Required: Power Drill, 7/16" Socket driver, Tape measure, Level, Safety glasses, Leather gloves

NOTE: Refer to door section identification, located in the pre-installation section of this manual.

NOTE: The graduated hinges can be identified by the number stamped on the lower hinge leaf.

NOTE: The #1 graduated end hinges serves as end hinges on the bottom section. The #1 graduated end hinges also serves as center hinges on all sections, except for the top section.

NOTE: The #2 graduated end hinges serves as end hinges on the Lock section.

NOTE: The #3 graduated end hinges serves as end hinges on the Intermediate I section.

NOTE: The #4 graduated end hinges serves as end hinges on the Intermediate II section (used only on the fourth section of a five section high door).

Starting on the left hand side of the bottom section, align the lower hinge leaf of the #1 graduated end hinge over the holes, located at the top of the end caps. Attach lower leaf to the end caps with (2) 1/4" - 14 x 5/8" self tapping screws. Repeat for other side. Next, align the lower hinge leaf of the #1 center hinges with the pre-punched holes at each center stile location(s), located at the top of the bottom section. Attach lower hinge leaf to the center stile with (2) 1/4" - 14 x 5/8" self tapping screws. Insert a short stem track roller into the hinge tube of the #1 graduated end hinges.

IMPORTANT: ONCE THE 1/4" - 14 X 5/8" SELF TAPPING SCREWS ARE SNUG AGAINST THE LOWER HINGE LEAFS, TIGHTEN AN ADDITIONAL 1/4 TO 1/2 TURN TO RECEIVE MAXIMUM DESIGN HOLDING POWER.

Repeat graduated hinge attachment using the appropriate graduated end hinges for all remaining sections except the top section.

IMPORTANT: WHEN PLACING SHORT STEM TRACK ROLLERS INTO THE #2 GRADUATED END HINGES AND HIGHER, THE SHORT STEM TRACK ROLLER GOES INTO HINGE TUBE FURTHEST AWAY FROM SECTION.

IMPORTANT: ONCE THE 1/4" - 14 X 5/8" SELF TAPPING SCREW IS SNUG AGAINST THE LOWER HINGE LEAF, TIGHTEN AN ADDITIONAL 1/4 TO 1/2 TURN TO RECEIVE MAXIMUM DESIGN HOLDING POWER.

7

Strut (U-Shaped)

Tools Required: Power Drill, 7/16" Socket driver, Tape measure, Level, Safety glasses, Leather gloves

NOTE: Refer to door section identification, located in the pre-installation section of this manual or refer to Parts Breakdown.

Using the strut schedule, determine the placement of the struts for your door width and door height.

INSTALLATION ON THE TOP SECTION:

Locate and center the strut at the top of the top section surface. Secure strut to top section using (2) 1/4" - 20 x 7/8" self drilling screws at each end and at each center stile locations.

INSTALLATION ON ALL OTHER SECTIONS:

NOTE: All struts are placed at the top of the sections and up against the bottom of the graduated hinges, for the intermediate, lock and bottom sections.

Locate and center the strut onto the section surface and up against the bottom of the hinges. Center the strut side to side. Secure strut to the section using (2) 1/4" - 20 x 7/8" self drilling screws at each end and center stile locations.

Strut Schedule

Door Width	4 Section High Door	5 Section High Door
8'0" - 13'11"	N/A	N/A
14'0" - 16'0"	(1) Strut Top Section	(2) Struts Top and Bottom Sections
16'1" - 18'0"	(3) Struts Top, Lock and Bottom Sections	(3) Struts Top, Intermediate I and Bottom Section
18'1" - 20'00"	(4) Struts All Sections	(5) Struts, All Sections

8

Top Fixtures

Tools Required: Power Drill, 7/16" Socket driver, Tape measure, Level, Safety glasses, Leather gloves

Align the upper-center hole of top fixture base with the hole in the end stile of the top section, as shown. Ensure the top fixture base is level and aligned with edge of the top section. Secure with (4) 1/4" - 20 x 7/8" self drilling screws, one in each corner of the top fixture base.

Insert short stem track roller into top fixture slide. Repeat for other side.

NOTE: If needed, ensure the top fixture slides are able to slide back and forth along the top fixture bases. If needed, loosen the (2) 1/4" - 20 flange hex nuts.

9

Cable Drum Assemblies and Track Rollers

Tools Required: Power Drill, 7/16" Socket driver, Tape measure, Level, Safety glasses, Leather gloves

NOTE: Refer to door section identification, located in the pre-installation section of this manual or refer to Parts Breakdown.

Starting on the left hand side, attach left hand bottom corner bracket to the left corner of the bottom section, making sure it is seated to the edges of the end cap, using (2) 1/4" - 20 x 11/16" self drilling screws (1) 1/4" - 20 x 5/8" tamper resistant screw. Repeat for other side.

NOTE: Only doors provided to professional installers, who have the required tools will be supplied with a tamper-resistant fastener. Use a 1/4" - 20 x 11/16" self drilling screw in bottom bracket, if not provided with a tamper-resistant screw.

NOTE: Cable drum assemblies are marked right and left hand.

WARNING

FAILURE TO ENSURE TIGHT FIT OF CABLE LOOP OVER MILFORD PIN COULD RESULT IN COUNTERBALANCE LIFT CABLE COMING OFF THE PIN, ALLOWING THE DOOR TO FALL, POSSIBLY RESULTING IN SEVERE OR FATAL INJURY.

Uncoil the counterbalance lift cables from the cable drum assemblies, making sure you place the left hand cable loop on the left hand milford pin of the bottom corner bracket and the right hand cable loop on the right hand milford pin of the bottom corner bracket.

NOTE: Check to ensure cable loops fits tightly over the milford pins.

Insert a short stem track roller with a roller spacer into each of the bottom corner brackets.

NOTE: Larger doors will use long stem track rollers with double graduated end hinges.

NOTE: Verify bottom weather seal is aligned with bottom section. If there is more than 1/2" excess weather seal on either side, trim weather seal even with bottom section.

10

Step Plate

Tools Required: Power Drill, 5/16"/7/16" Drill bits, 1/4" Wrench, Tape measure, Phillips head screwdriver, Level, Safety glasses, Leather gloves

NOTE: Depending on your door, you may have two different kinds of Step Plates or two of the same kind of Step Plates. Refer to Package Contents, to determine which Step Plates you have.

IF YOU HAVE TWO OF THE SAME KINDS OF STEP PLATES:

Locate the center most center stile of the bottom section of the door. On the inside of the door, center the step plate on the center most stile no higher than 6" from the bottom of the door. Using the step plate holes as a template, drill a 5/16" dia. hole along each side of the center stile, through the face of the door. Drill through insulation and door's face on an insulated door.

IMPORTANT: BE EXTREMELY CAREFUL TO KEEP DRILL STRAIGHT.

Mount the inside step plate and the outside step plate back to back, straddling the center stile. Secure with (2) 1/4" - 20 x 2-3/4" carriage bolts and 1/4" - 20 hex nuts.

IMPORTANT: DO NOT MOUNT THE STEP PLATE HIGHER THAN 6" FROM THE BOTTOM OF THE SECTION.

IF YOU HAVE TWO DIFFERENT KINDS OF STEP PLATES:

Locate the center most center stile on the bottom section of the door. On the inside of the door and using the pre-punched holes at the bottom of the center stile as a template, drill (2) 7/32" dia. holes through the section. Using the previously drilled holes as a guide, enlarge the holes from outside the door to 7/16" dia. and assemble the outside and inside step plates to the section using (2) #8 x 1-5/8" screws.

NOTE: Do not drill through or enlarge holes on the inside of the door.

NOTE: After completing this step, continue with Step Lift Handles.

11

Lift Handle

Tools Required: Power Drill, 9/32"/1/2" Drill bits, 1/4" Wrench, Tape measure, Phillips head screwdriver, Level, Safety glasses, Leather gloves

NOTE: Doors with a Keyed lock do not require this lift handle.

Locate the inside center stile or the desired lift handle location on the lock (2nd) section of the door. Position the lower hole in the lift handle 4" from the bottom of the lock (2nd) section.

IMPORTANT: THE DISTANCE BETWEEN THE STEP PLATE AND THE MIDDLE OF THE LIFT HANDLE MUST BE 20" MINIMUM TO 30" MAXIMUM. IF NECESSARY REPOSITION THE UPPER LIFT HANDLE TO STAY WITHIN THE REQUIRED DIMENSION.

Using the lift handle holes as a template, drill (2) 9/32" dia. holes through the lock section. Enlarge the holes from the outside the door to 1/2" dia.

NOTE: Do not drill through or enlarge holes on the inside of the door.

Assemble the outside and inside lift handles to the lock section using (2) spacers, (2) 1/4" - 20 x 2-1/2" carriage bolts and (2) 1/4" - 20 hex nuts.

12

Bottom Section

Tools Required: Tape measure, Level, Wooden shims (if necessary), Safety glasses, Leather gloves

Center the bottom section in the door opening. Level the section using wooden shims (if necessary) under the bottom section. When the bottom section is leveled, temporarily hold it in place by driving a nail into the jamb and bending it over the edge of the bottom section on both sides.

13

Vertical Tracks

Tools Required: Power Drill, 3/16" Drill bit, 7/16" Socket driver, Tape measure, Level, Step ladder, Safety glasses, Leather gloves

NOTE: Depending on your door, you may have Quick Install Flag Angles, Fully Adjustable Flag Angles or you may have Riveted Vertical Track Assemblies. Refer to Package Contents / Parts Breakdown, to determine which Flag Angles / Vertical Track Assemblies you have.

IMPORTANT: IF YOUR DOOR IS TO BE INSTALLED PRIOR TO A FINISHING CONSTRUCTION

OF THE BUILDING'S FLOOR, THE VERTICAL TRACKS AND THE DOOR BOTTOM SECTION ASSEMBLY SHOULD BE INSTALLED SUCH THAT WHEN THE FLOOR IS CONSTRUCTED, NO DOOR OR TRACK PARTS ARE TRAPPED IN THE FLOOR CONSTRUCTION.

IMPORTANT: THE TOPS OF THE VERTICAL TRACKS MUST BE LEVEL FROM SIDE TO SIDE. IF THE BOTTOM SECTION WAS SHIMMED TO LEVEL IT, THE VERTICAL TRACK ON THE SHIMMED SIDE MUST BE RAISED THE HEIGHT OF THE SHIM.

Starting on the left hand side of the bottom section, remove the nail. Position the left hand vertical track assembly over the track rollers of the bottom section. Make sure the counterbalance lift cable is located between the track rollers and the door jamb. Drill 3/16" pilot holes into the door jamb for the lag screws.

For Quick Install Flag Angles, Fully Adjustable Flag Angles or Riveted Vertical Track Assemblies: Loosely fasten jamb brackets and flag angle to the jamb using 5/16" x 1-5/8" lag screws. Tighten lag screws, securing the bottom jamb bracket to jamb, maintain 3/8" to 5/8" spacing, between the bottom section and vertical track. Hang counterbalance lift cable over flag angle. Repeat same process for other side.

14

Stacking Sections

Tools Required: Power drill, 7/16" Socket driver, Tape measure, Level, Step ladder, Safety glasses, Leather gloves

NOTE: Refer to door section identification, located in the pre-installation section of this manual.

NOTE: The sections can be identified by the graduation of the factory installed graduated end hinges. The smallest graduated end hinge on section should be stacked on top of the bottom section, with each graduated end hinge increasing as the sections are stacked, see Parts Breakdown.

NOTE: Make sure end and center hinges are flipped down, when stacking another section on top.

Place track rollers into graduated end hinges of remaining sections.

NOTE: Larger doors will use long stem track rollers with double graduated end hinges.

With assistance, lift second section and guide the track rollers into the vertical tracks. Lower section until it is seated against bottom section. Flip hinges up. Fasten center hinge(s) first; then end hinges last using 1/4" - 20 x 7/8" self-drilling screws.

Repeat same process for other sections, except top section.

IMPORTANT: PUSH & HOLD THE HINGE LEAFS SECURELY AGAINST THE SECTIONS WHILE SECURING WITH 1/4" - 20 X 7/8" SELF-DRILLING SCREWS. THERE SHOULD BE NO GAP BETWEEN THE HINGE LEAFS AND THE SECTIONS.

NOTE: Install lock at this time (sold separately). See optional installation step, Side Lock.

15

Top Section

Tools Required: Power drill, 7/16" Socket driver, 7/16" Wrench, Step ladder, Tape measure, Safety glasses, Leather gloves

Place the top section in the opening. Temporarily secure the top section by driving a nail in the header near the center of the door and bending it over the top section. Now, flip up the hinge leaves, hold tight against section, and fasten center hinges first and end hinges last (refer to step, Stacking Sections). Vertical track alignment is critical. Position flag angle or wall angle between 1-11/16" (43 mm) to 1-3/4" (44 mm) from the edge of the door; tighten the bottom lag screw. Flag angles must be parallel to the door sections. Repeat for other side.

IMPORTANT: THE DIMENSION BETWEEN THE FLAG ANGLES OR WALL ANGLES MUST BE DOOR WIDTH PLUS 3-3/8" (86MM) TO 3-1/2" (89 MM) FOR SMOOTH, SAFE DOOR OPERATION.

FOR QUICK INSTALL TRACK: Complete the vertical track installation by securing the jamb bracket(s) and tightening the other lag screws. Repeat for other side.

For Fully Adjustable track or Riveted Track: Complete the vertical track installation by securing the jamb bracket(s) and tightening the other lag screws. Push the vertical track against the track rollers so that the track rollers are touching the deepest part of the curved side of the track; tighten all the track bolts and nuts. Repeat for other side.

16

Horizontal Tracks

Tools Required: Ratchet wrench, 9/16" 7/16" Socket, 9/16" 7/16" Wrench, Step ladder, Tape measure, Safety glasses, Leather gloves

NOTE: Depending on your door, you may have Quick Install Flag Angles, Fully Adjustable Flag Angles or you may have Riveted Vertical Track Assemblies. Refer to Package Contents / Parts Breakdown, to determine which Flag Angles / Vertical Track Assemblies you have.

WARNING

DO NOT RAISE DOOR UNTIL HORIZONTAL TRACKS ARE SECURED AT REAR, AS OUTLINED IN STEP, REAR BACK HANGS, OR DOOR COULD FALL FROM OVERHEAD POSITION CAUSING SEVERE OR FATAL INJURY.

IF YOU HAVE QUICK INSTALL FLAG ANGLES: To install horizontal track, place the curved end over the top track roller of the top section. Align key slot of the horizontal track with the Quick Install tab of the flag angle. Push curved portion of horizontal track down to lock in place.

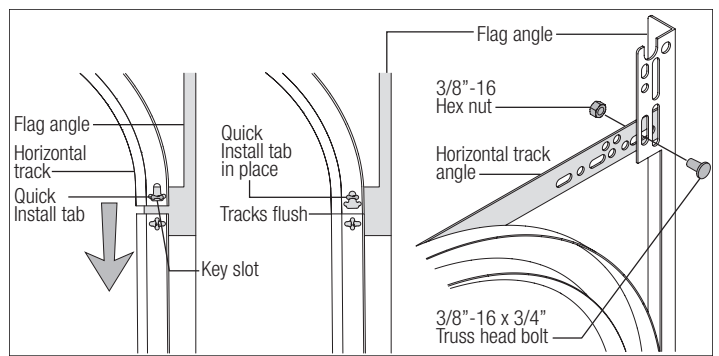

FOR OTHER FLAG ANGLES: To install horizontal track, place the curved end over the top track roller of the top section. Align the bottom of the horizontal track with the top of the vertical track. If you have Quick Install horizontal track, tighten the horizontal track to the flag angle with a stud plate and (2) 1/4" - 20 flange hex nuts. If you have Universal horizontal track, tighten the horizontal track to the flag angle with (2) 1/4" - 20 x 9/16" track bolts and (2) 1/4" - 20 flange hex nuts.

Next level the horizontal track assembly and bolt the horizontal track angle to the first encountered slot in the flag angle / angle mount using (1) 3/8" - 16 x 3/4" truss head bolt and (1) 3/8" - 16 hex nut. Repeat for other side. Next remove the nail that was temporarily holding the top section in place, installed in step, Top Section.

IMPORTANT: FAILURE TO REMOVE NAIL BEFORE ATTEMPTING TO RAISE DOOR COULD CAUSE PERMANENT DAMAGE TO TOP SECTION.

17

Adjusting Top Fixtures

Tools Required: 7/16" Wrench, Step ladder, Tape measure, Safety glasses, Leather gloves

ADJUSTING TOP FIXTURE SLIDE:

With horizontal tracks installed, you can now adjust the top fixtures. Vertically align the top section of the door with the lower sections. Once aligned, position the top fixture slide, out against the horizontal track. Maintaining the slide's position, tighten the (2) 1/4" - 20 flange hex nuts to secure the top fixture slide to the top fixture base. Repeat for other side.

REVERSING THE TOP FIXTURE SLIDE, IF NEEDED:

NOTE: Depending on your application, you may have to reverse the top fixture slide for more adjustability, prior to securing it to the top fixture base.

Remove the top fixture slide by removing the (2) 1/4" - 20 flanged hex nuts and the (2) 1/4" - 20 x 5/8" carriage bolts. Remove the track roller from the top fixture slide and flip the top fixture slide in the opposite direction. Re-insert the track roller back into the top fixture slide and loosely fasten the top fixture slide to the top fixture base by re-using the (2) 1/4" - 20 x 5/8" carriage bolts and (2) 1/4" - 20 flange hex nuts. Repeat same process for other side. Now follow the instructions at the top of this step "Adjusting top fixture slide(s)".

18

TorqueMaster® Spring Tube

Tools Required: Safety glasses, Leather gloves

TorqueMaster® springs come lubricated and pre-assembled inside the TorqueMaster® spring tube. To prepare for install, lay the spring tube assembly on the floor, inside garage, in front of the door, and with the labeled end to the left. Next, remove the shipping boots from the ends of the TorqueMaster® spring tube.

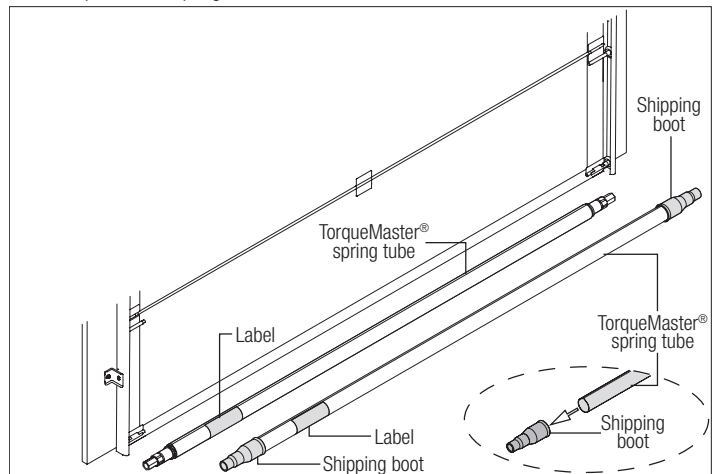

19

Center Bracket Bushing Assembly

Tools Required: Safety glasses, Leather gloves

Being cam shaped, the center bushing only fits one way. Slide the center bracket bushing as-

assembly towards the center of the TorqueMaster® spring tube, from the right side, as shown.

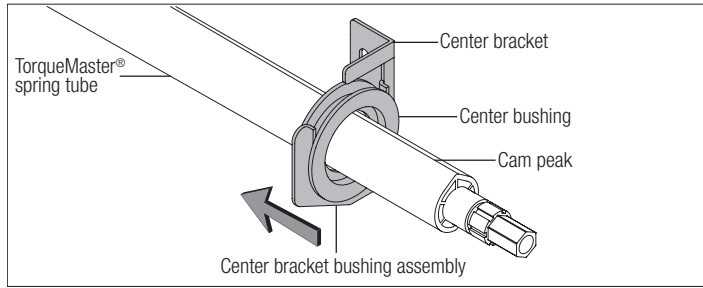

20

Drum Wraps (Optional)

Tools Required: Safety glasses, Leather gloves

NOTE: If you don't have drum wraps (optional), then skip this step. Refer to Package Contents / Parts Breakdown, to determine if you have drum wraps.

Drum wraps are marked right and left hand. Beginning with the left hand side, slide the left hand drum wrap onto the TorqueMaster® spring tube. Repeat for the right hand side. The drum wrap will be secured later, in Step, Securing Drum Wraps.

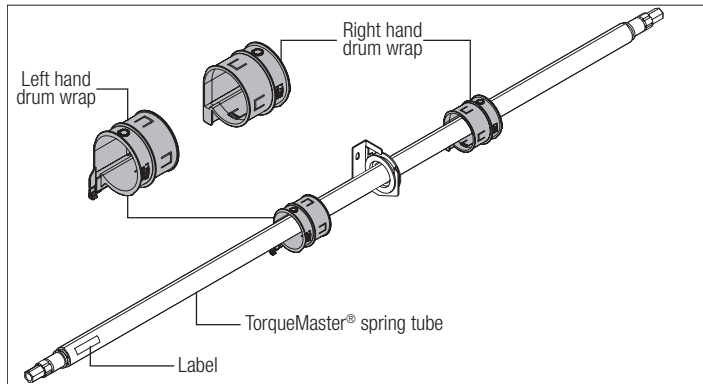

21

Cable Drum Assemblies

Tools Required: Tape measure, Step ladder, Safety glasses, Leather gloves

Shake the TorqueMaster® spring tube assembly gently to extend the winding shafts out about 5" on each side. For **single spring applications**, there will be no left hand spring in the TorqueMaster® spring tube assembly. Lift the TorqueMaster® spring tube assembly and rest it on top of the flag angles.

NOTE: Cable drum assemblies are marked right and left hand. Cable drums and TorqueMaster® spring tube assembly are cam shaped to fit together only one way.

Starting on the right hand side, pre-wrap the cable drum with the counterbalance lift cable 1-1/2 wraps, as shown. Position the TorqueMaster® spring tube assembly so the cam peak is pointing straight up. Slide the cable drum over the winding shaft until the cable drum seats against the TorqueMaster® spring tube assembly. The winding shaft must extend past the cable drum far enough to expose the splines and the grooves. Align the winding shaft grooves with the round notch in the flag angle.

FOR DOUBLE SPRING APPLICATIONS: Repeat for left hand side.

FOR SINGLE SPRING APPLICATIONS: Insert the idler bracket into the left hand cable drum. Lightly press the idler bracket into the cable drum until two distinct clicks are heard, or the bracket is inserted all the way.

IMPORTANT: ENSURE THE SNAPS ON THE IDLER BRACKET (LEFT HAND SIDE) ARE ENGAGED INTO THE LEFT HAND CABLE DRUM, SO THAT IT DOES NOT COME BACK OUT.

NOTE: The idler bracket is designed for permanent assembly. Do not attempt to remove idler bracket once inserted into the cable drum.

Pre-wrap the left hand cable drum with the counterbalance lift cable 1-1/2 wraps and slide the cable drum over the TorqueMaster® spring tube assembly. Slide the TorqueMaster® spring tube assembly into the cable drum until the cable drum seats up against the TorqueMaster® spring tube assembly.

NOTE: The idler bracket must extend past the cable drum far enough to expose the groove. Align the idler bracket groove with the round notch in the flag angle.

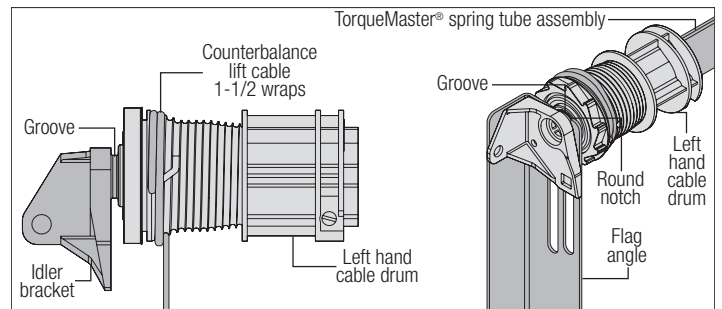
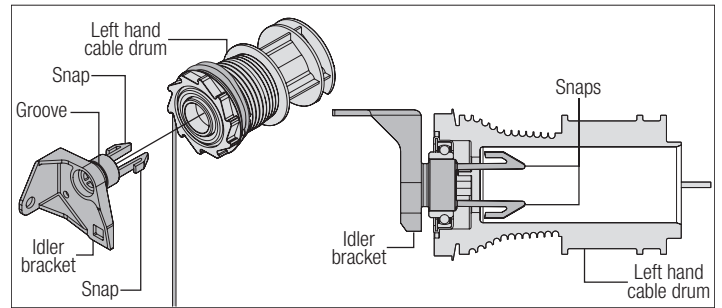
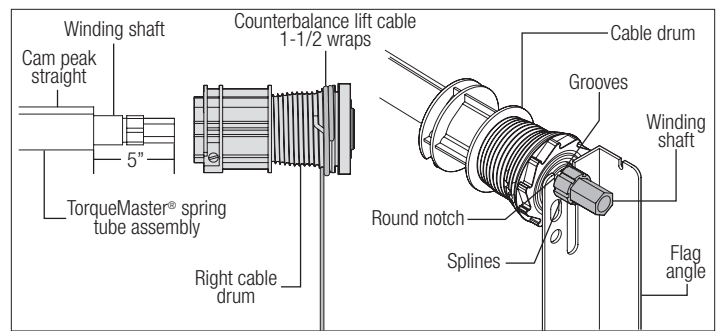

22

End Brackets

Tools Required: Power drill, 3/16" Drill bit, 7/16" Socket driver, 1/2" Wrench, Tape measure, Step ladder, Safety glasses, Leather gloves

IMPORTANT: WARNING TAGS MUST BE SECURELY ATTACHED TO END BRACKET(S).

NOTE: On single spring applications, the idler end bracket was positioned in a previous step, but must be fastened in this step.

NOTE: Prior to fastening the end bracket(s) / idler end bracket into the door jamb, pilot drill using a 3/16" drill bit.

Beginning with the right hand side, slide the end bracket onto the winding shaft so that the splines in the ratchet wheel fit onto the winding shaft grooves. Attach the end bracket to the flag angle using (1) 5/16" - 18 x 3/4" carriage bolt, (1) 5/16" washer and (1) 5/16" - 18 hex nut. Then secure the end bracket to the jamb using (1) 5/16" x 1-5/8" lag screw.

NOTE: If ratchet wheel falls out of end bracket, refer to illustration for proper insertion orientation.

FOR DOUBLE SPRING APPLICATIONS: Repeat same process for left hand end bracket.

FOR SINGLE SPRING APPLICATIONS: Secure the idler bracket to the flag angle using (1) 5/16" - 18 x 3/4" carriage bolt, (1) 5/16" washer and (1) 5/16" - 18 hex nut. Then secure the idler bracket to the jamb using (1) 5/16" x 1-5/8" lag screw.

IMPORTANT: FOR SINGLE SPRING DOORS, ENSURE THE LEFT HAND CABLE DRUM BEARING IS ALL THE WAY TO THE LEFT AND UP AGAINST THE FLAG ANGLE. IF THE CABLE DRUM IS PULLED AWAY FROM THE FLAG ANGLE, THEN THE IDLER BRACKET CAN RUB AGAINST THE CABLE DRUM CAUSING NOISE.

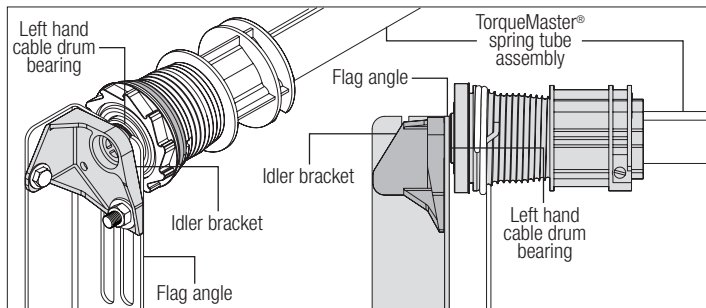
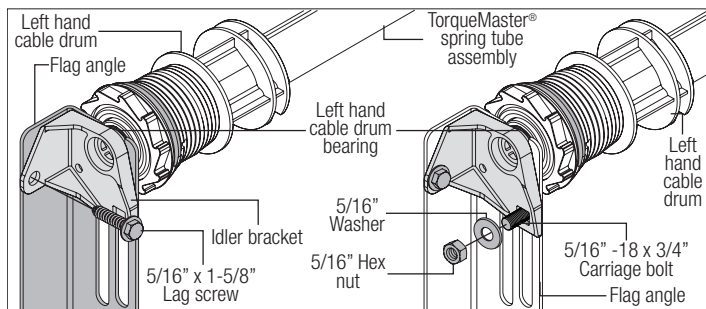
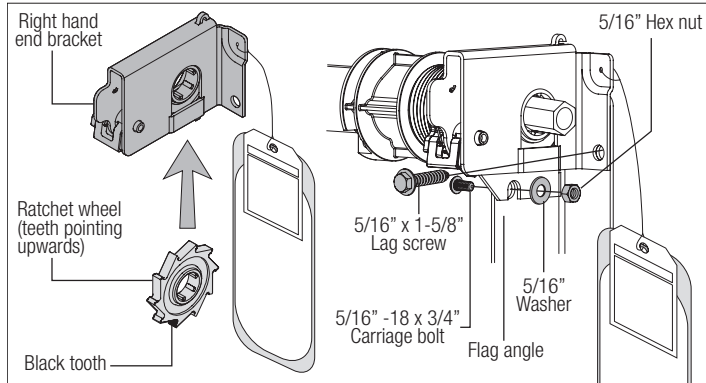
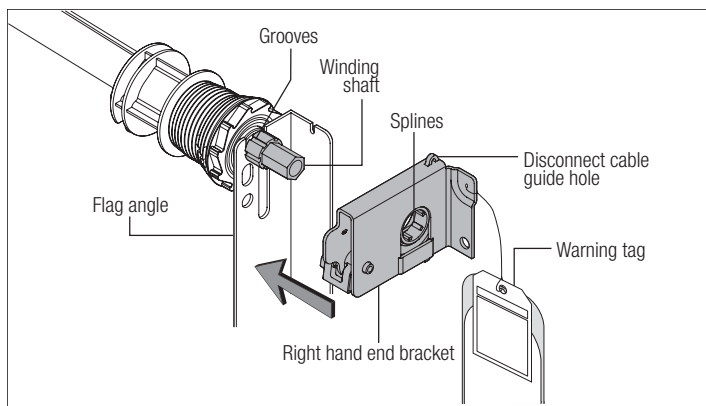

23

Securing Center Bracket Bushing Assembly

Tools Required: Power drill, 3/16" Drill bit, 7/16" Socket driver, 1/2" Wrench, Level, Tape measure, Step ladder, Safety glasses, Leather gloves

IMPORTANT: TORQUEMASTER® SPRING TUBE MUST BE LEVEL BEFORE SECURING CENTER BRACKET BUSHING ASSEMBLY TO HEADER.

To locate the center bracket bushing assembly, mark the header halfway between the flag angles and level the TorqueMaster® spring tube. Drill 3/16" pilot holes into header for the lag screws. Fasten the center bracket bushing assembly to the header using (2) 5/16" x 1-5/8" lag screws.

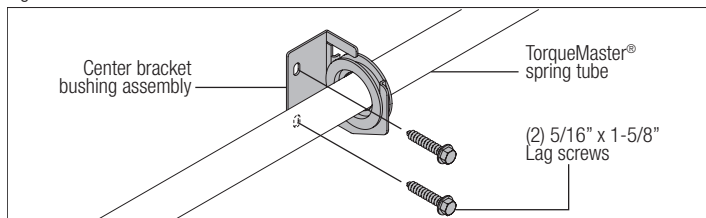

24

Securing Door For Winding Spring(s)

Tools Required: Vice Clamps, Step ladder, Safety glasses, Leather gloves

With the door in the fully closed position, place vice clamps onto both vertical tracks just above the third track roller. This is to prevent the garage door from rising while winding spring(s).

NOTE: Check the following before attempting to wind spring(s):

- Counterbalance lift cables are secured at bottom corner brackets.
- Counterbalance lift cables are routed unobstructed to cable drums.
- Counterbalance lift cables are correctly installed and wound onto cable lift drums.
- TorqueMaster® spring tube is installed correctly.
- Review the label attached to the spring warning tag, to determine number of spring turns required.

NOTE: Door MUST be closed and locked when winding or making any adjustments to the spring(s).

WARNING

FAILURE TO PLACE VICE CLAMPS ONTO VERTICAL TRACK CAN ALLOW DOOR TO RAISE AND CAUSE SEVERE OR FATAL INJURY.

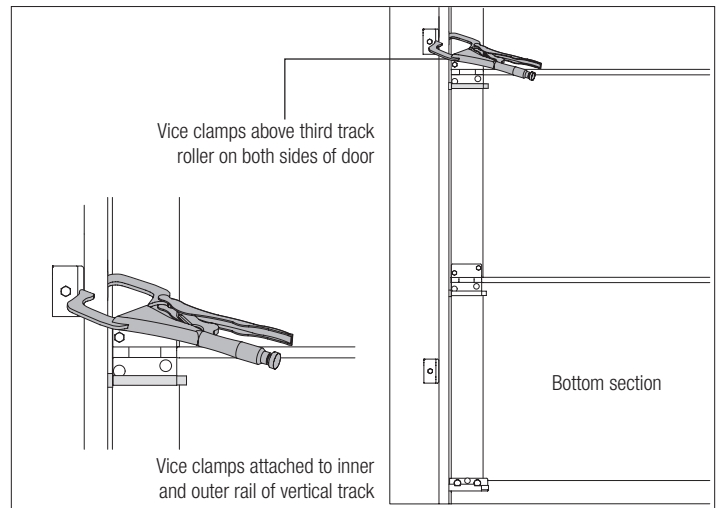

25

Lift Cable Adjustments

Tools Required: Locking pliers, Flat tip screwdriver, Step ladder, Tape measure, Pliers / Wire cutters, Safety glasses, Leather gloves

Starting on the right side, adjust the cable drum assembly by rotating the drum until the set screw faces directly away from the header. The position of the cam peak on the TorqueMaster® spring tube should be pointing straight up.

Loosen the set screw no more than 1/2 turn. Ensure counterbalance lift cable is aligned and seated in the first and second grooves of the cable drum. Pull on the end of the cable to remove all cable slack.

Snug the set screw and then tighten an additional 1-1/2 turns. Measure approximately 6" of cable and cut off excess cable. Insert end of the cable into the hole of cable drum. Repeat for left hand cable drum assembly.

IMPORTANT: ENSURE THE COUNTERBALANCE LIFT CABLE IS ALIGNED AND SEATED IN THE FIRST AND SECOND GROOVES OF THE CABLE DRUM PRIOR TO WINDING SPRINGS.

NOTE: Illustration shows the right hand cable drum assembly.

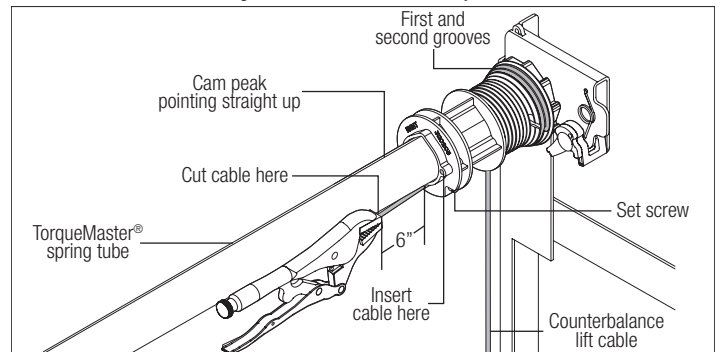

26

Winding Spring(s)

Tools Required: Ratchet wrench, 5/8" Socket, 3" Socket extension, Pliers / Wire cutters, Flat tip screwdriver, Step ladder, Tape measure, Safety glasses, Leather gloves

WARNING

WINDING TORSION SPRING(S) IS AN EXTREMELY DANGEROUS PROCEDURE AND SHOULD BE PERFORMED ONLY BY A TRAINED DOOR SYSTEM

WARNING

IT IS RECOMMENDED THAT LEATHER GLOVES BE WORN WHILE WINDING SPRINGS. FAILURE TO WEAR GLOVES MAY CAUSE INJURY TO HANDS.

Double check to ensure the counterbalance lift cable is aligned in the first and second grooves of the cable drum, see step Lift Cable Adjustments. There are two methods for counting the spring turns as you wind. One method is to identify the black tooth on the ratchet wheel inside of the end bracket. When the wheel makes one revolution and the tooth returns to its starting point, one turn has been made. The other method is to make a mark on the winding shaft (or socket) and end bracket, and count your turns in this manner.

Starting on the right hand side, turn the pawl knob on the end bracket to the upper position. Using a ratchet wrench with a 5/8" socket and a 3" extension, wind the spring by rotating the winding shaft counter clockwise, while watching either the black tooth on the ratchet wheel or the mark on the winding shaft.

NOTE: A 3" extension is recommended for added clearance from the horizontal track angle.

IMPORTANT: PAWL KNOB MUST BE IN UPPER POSITION TO ADD / REMOVE REQUIRED NUMBER OF SPRING TURNS.

After 2 to 3 turns, remove the ratchet wrench and adjust the counterbalance lift cable on the left side. Ensure counterbalance lift cables are in the first and second grooves of the cable drums, as shown in step Lift Cable Adjustments.

NOTE: Single spring applications require no spring winding on the left hand side, but lift cable tension needs to be adjusted.

IMPORTANT: COUNTERBALANCE LIFT CABLE TENSION MUST BE EQUAL ON BOTH SIDES PRIOR TO FULLY WINDING SPRINGS.

See the Winding Spring Turn Chart for the required number of winding turns:

FOR SINGLE SPRING APPLICATIONS:

Return to the right hand end bracket and continue winding the spring to the required number of turns for your door following the double spring instructions below. Place pawl knob in lower position.

FOR DOUBLE SPRING APPLICATIONS:

Either use the black tooth on the ratchet wheel for winding reference or place a mark on the winding shaft and end bracket. Place the ratchet wrench with 5/8" socket and a 3" extension onto the left hand winding shaft end. To wind the spring, rotate the winding shaft clockwise, while watching the black tooth on the ratchet wheel or the mark on the winding shaft. Rotate the winding shaft to the required number of winding turns for your door. Then return to the right hand side and wind the right hand spring to the required number of turns. Place pawl knob in lower position on both sides.

IMPORTANT: MARK THE NUMBER OF SPRING TURNS ONTO THE END BRACKET WARNING TAG.

NOTE: Since total turns to balance door can deviate from winding spring turn chart values by $\pm 1/2$ turn, adjustments to the recommended number of turns may be required after rear back hangs are installed.

WINDING SPRING TURN CHART

DOOR HEIGHT	SPRING TURNS
6'-0"	14
6'-3"	14-1/2
6'-5"	15
6'-6"	15
6'-8"	15-1/2
6'-9"	15-1/2
7'-0"	16
7'-3"	16-1/2
7'-6"	17
7'-9"	17-1/2
8'-0"	18

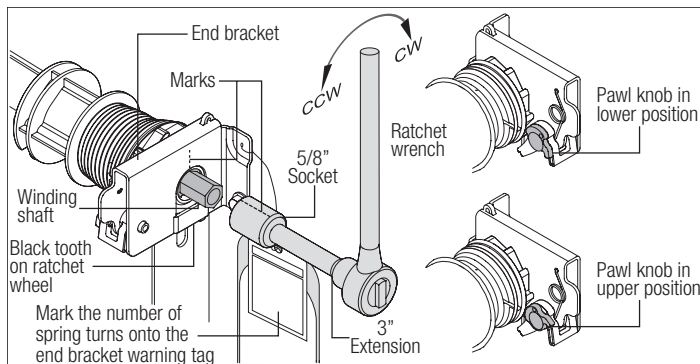

27

Securing Drum Wraps (Optional)

Tools Required: Step ladder, Safety glasses, Leather gloves

NOTE: If you don't have drum wraps (optional), then skip this step. Refer to Package Contents / Parts Breakdown, to determine if you have drum wraps.

Starting on the left hand side, position the left hand drum wrap, as shown. Slide the left hand drum wrap over the cable drum assembly.

IMPORTANT: PULL THE COUNTERBALANCE LIFT CABLE AWAY FROM THE HEADER TO CLEAR THE LATCH, WHILE SIMULTANEOUSLY SLIDING THE DRUM WRAP AGAINST THE LAST RIB UNTIL THE THREE CATCHES ENGAGE THE 3RD RIB.

Secure the hinge latch by rotating upward until a distinct snap is felt. Confirm the catch is fully engaged by lightly tugging on it. Repeat the same process for right hand side.

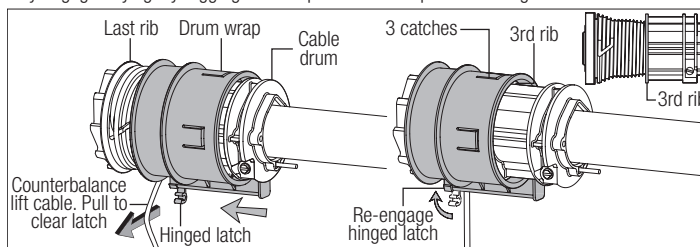

28

Rear Back Hangs

Tools Required: Ratchet wrench, Socket: 1/2" 5/8", Wrench: 1/2" 5/8", 3" Socket extension, (2) Vice clamps, Step ladder, Tape measure, Safety glasses, Leather gloves

IMPORTANT: HOLD THE DOOR DOWN TO PREVENT IT FROM RISING UNEXPECTEDLY IN THE EVENT THE SPRING(S) WAS OVER-WOUND AND CAUTIOUSLY REMOVE VICE CLAMPS FROM VERTICAL TRACKS.

Raise the door until the top section and half of the next section are in the horizontal track radius. Do not raise door any further since rear of horizontal tracks are not yet supported.

WARNING

RAISING DOOR FURTHER CAN RESULT IN DOOR FALLING AND CAUSE SEVERE OR FATAL INJURY.

Clamp a pair of vice clamps onto the vertical tracks just above the second track roller on one side, and just below the second track roller on the other side. This will prevent the door from raising or lowering while installing the rear back hangs.

Using the chart (Perforated Angle Gauge Weight Limitations) below, use the appropriate perforated angle (may not be supplied), (2) 5/16" x 1-5/8" hex head lag screws and (3) 5/16" bolts with nuts (may not be supplied), fabricate rear back hangs for the horizontal tracks. Attach the horizontal tracks to the rear back hangs with 5/16" - 18 x 1" hex bolts and nuts (may not be supplied). Horizontal tracks must be level and parallel with door within 3/4" to 7/8" maximum of door edge.

WARNING

EXCEEDING THE RECOMMENDED LISTED DOOR WEIGHT LIMITATIONS OF SPECIFIC GAUGE PERFORATED ANGLES MAY RESULT IN DOOR FALLING WHEN RAISED, CAUSING SEVERE OR FATAL INJURY.

WARNING

VERIFY PERFORATED BACK HANG ANGLE LOAD RATINGS WITH BACK HANG ANGLE SUPPLIER.

Perforated Angle Gauge Weight Limitations:

Perforated Angle Gauge

Door Weight

Perforated Angle Gauge Weight Limitations:

1-1/4" x 1-1/4" x 13 Gauge	Door Weight Less Than 305 lbs.
1-1/4" x 1-1/4" x 15 Gauge	Door Weight Less Than 220 lbs.
1-1/4" x 1-1/4" x 16 Gauge	Door Weight Less Than 175 lbs.

NOTE: If an opener is installed, position horizontal tracks one hole above level when securing it to the rear back hangs.

⚠ WARNING
KEEP HORIZONTAL TRACKS PARALLEL AND WITHIN 3/4" TO 7/8" MAXIMUM OF DOOR EDGE, OTHERWISE DOOR COULD FALL, RESULTING IN SEVERE OR FATAL INJURY.

IMPORTANT: DO NOT SUPPORT THE WEIGHT OF THE DOOR ON ANY PART OF THE REAR BACK HANGS THAT CANTILEVERS 4" OR MORE BEYOND A SOUND FRAMING MEMBER.

NOTE: If rear back hangs are to be installed over drywall, use (2) 5/16" x 2" hex head lag screws and make sure lag screws engage into solid structural lumber.

NOTE: 26" angle must be attached to sound framing members and **nails should not be used.**

Now, permanently attach the weatherstrips on both door jambs and header. The weatherstrips were temporarily attached in Preparing the Opening, in the pre-installation section of this manual.

NOTE: When permanently attaching the weatherstrips to the jambs, avoid pushing the weatherstrips too tightly against the face of door.

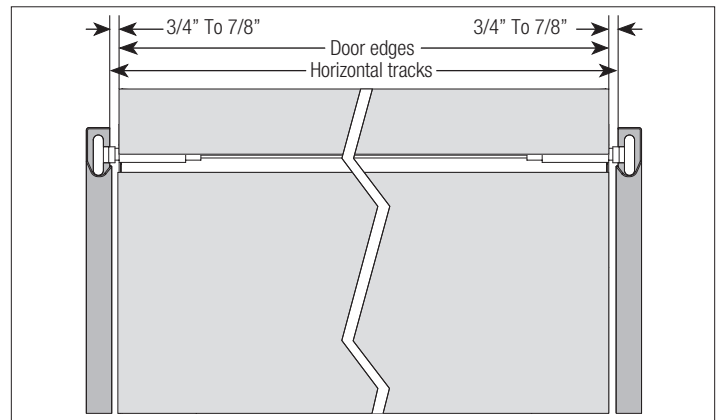
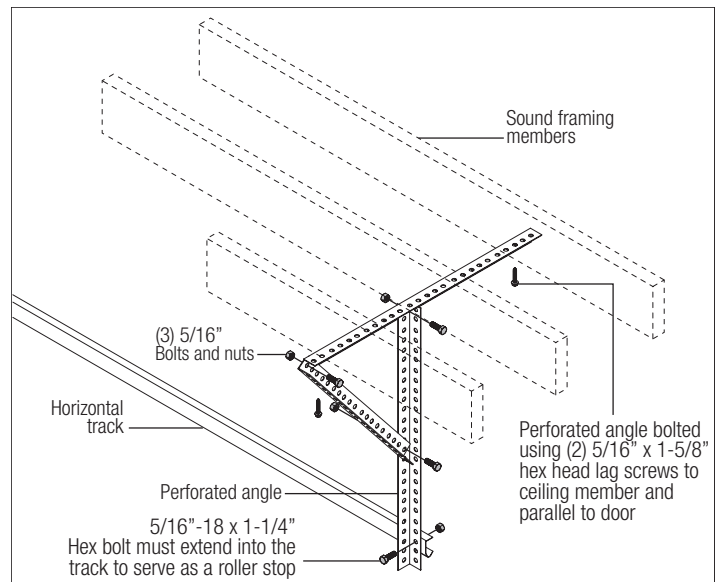
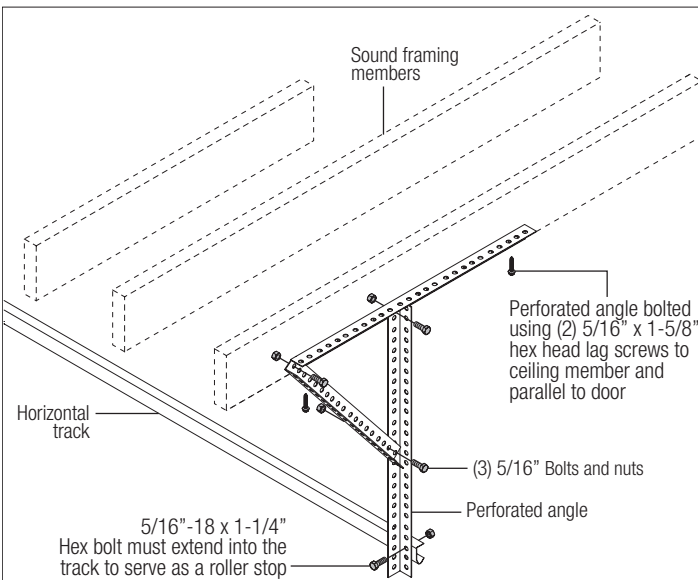
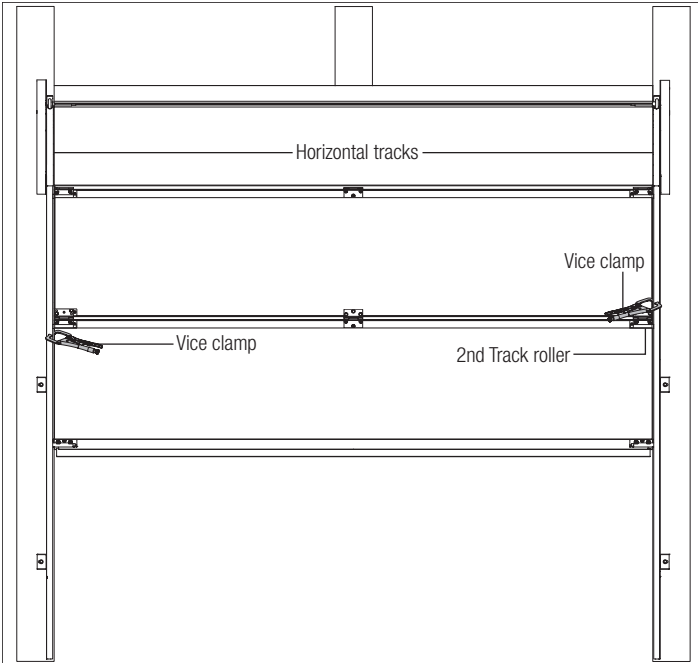

29 Balancing Door
 Tools Required: Ratchet wrench, Socket: 5/8", Wrench: 5/8", 3" Socket extension, (2) Vice clamps, Step ladder, Tape measure, Safety glasses, Leather gloves

NOTE: Windows will cause the top section to be significantly heavier than the remaining sections. Wayne Dalton attempts to balance the door at the top and bottom. To prevent any sudden door acceleration between the top and bottom, we recommend motor operating all doors with windows. Doors with windows in the top section should not be manually operated.

Remove any vice clamps. Lift the door and check its balance. Adjust spring(s) if door lifts by itself (hard to pull down) or if door is difficult to lift (easy to pull down). Anytime spring adjustments are made, ratchet pawl knob must be in the upper position. An unbalanced door can cause TorqueMaster® Plus operation problems.

Close the door and place vice clamps onto both vertical tracks just above the third track roller. This is to prevent the garage door from rising while adjusting the counterbalance spring(s).

IMPORTANT: TO ADJUST SPRINGS, ONLY ADD OR REMOVE A MAXIMUM OF 3/10 OF A TURN (THREE TEETH ON THE RATCHET WHEEL) AT A TIME. BOTH SIDES NEED TO BE ADJUSTED EQUALLY ON DOUBLE SPRING DOORS.

Add spring tension: The ratchet wheel is made of 10 teeth. To add spring tension, ensure the ratchet and socket is set so that it will tighten counter clockwise on the right hand side and clockwise on the left hand side. Place pawl knob in upper position. Place the ratchet wrench with 5/8" socket and 3" socket extension onto the winding shaft, pull down to add 3/10 of a turn. Watch as three teeth of the ratchet wheel pass over the pawl, creating three "clicks". Place pawl knob in lower position.

Remove spring tension: To remove spring tension, place a regular 5/8" wrench onto the winding shaft. Place pawl knob in upper position. Pull down on the wrench to relieve pressure between the pawl and the ratchet wheel. Push in on the pawl to allow the three ratchet wheel teeth to pass by the pawl, as you carefully allow the wrench to be rotated upward by the spring tension, release the pawl to allow it to engage with the ratchet wheel. Place pawl knob in lower position.

IMPORTANT: BE PREPARED TO HOLD THE FULL TENSION OF THE SPRING.

IMPORTANT: DO NOT ADD OR REMOVE MORE THAN 1 SPRING TURN (1 SPRING TURN EQUALS 10 TEETH ON RATCHET WHEEL) FROM THE RECOMMENDED NUMBER OF TURNS SHOWN ON THE WINDING SPRING TURN CHART.

If the door still does not operate easily, lower the door into the closed position, unwind spring(s) completely, and recheck the following items:

- 1.) Check the door for level.

- 2.) Check the TorqueMaster® spring tube and flag angles for level and plumb.
- 3.) Check the distance between the flag angles, which must be door width plus 3-3/8" to 3-1/2".
- 4.) Check the counterbalance lift cables for equal tension, adjust if necessary.
- 5.) Rewind the spring(s).
- 6.) Make sure door isn't rubbing on jambs.

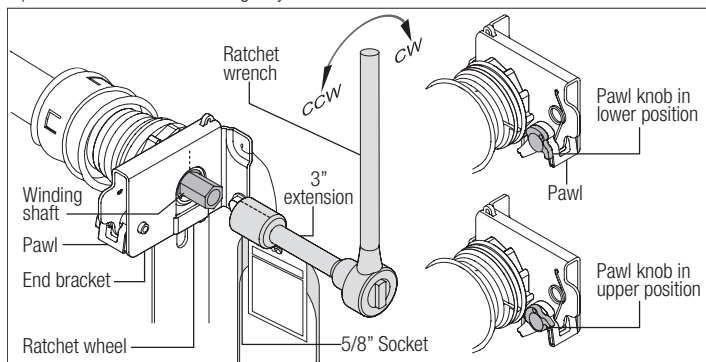

MAINTENANCE

Cleaning Your Garage Door

IMPORTANT: DO NOT USE A PRESSURE WASHER ON YOUR GARAGE DOOR!

While factory-applied finishes on garage doors are durable, it is desirable to clean them on a routine basis. Some discoloration of the finish may occur when a door has been exposed to dirt-laden atmosphere for a period of time. Slight chalking may also occur as a result of direct exposure to sunlight.

Cleaning the door will generally restore the appearance of the finish. To maintain an aesthetically pleasing finish of the garage door, a periodic washing of the garage door is recommended.

THE FOLLOWING CLEANING SOLUTION IS RECOMMENDED:

A mild detergent solution consisting of one cup detergent (with less than 0.5% phosphate) dissolved into five gallons of warm water will aid in the removal of most dirt.

NOTE: The use of detergents containing greater than 0.5% phosphate is not recommended for use in general cleaning of garage doors.

NOTE: Be sure to clean behind weatherstrips on both sides and top of door.



CAUTION: NEVER MIX CLEANSERS OR DETERGENTS WITH BLEACH.

GLASS CLEANING INSTRUCTIONS

Clean with a mild detergent solution (same as above) and a soft cloth. After cleaning, rinse thoroughly.

ACRYLIC CLEANING INSTRUCTIONS

Clean acrylic glazing with nonabrasive soap or detergent and plenty of water. Use your bare hands to feel and dislodge any caked on particles. A soft, grit-free cloth, sponge or chamois may be used to wipe the surface. Do not use hard or rough cloths that will scratch the acrylic glazing. Dry glazing with a clean damp chamois.

NOTE: Do not use any window cleaning fluids, scouring compounds, gritty cloths or solvent-based cleaners of any kind.

Painting Your Garage Door

Refer to Instruction Insert "**Field Painting and Finishing Fiberglass or Steel Door Sections**".

Maintaining The Finish On Your Garage Door

If the factory finish is beginning to fade, the door may require a field applied top clear coat. Depending on environment and usage, this may be necessary after 1 to 3 years of use. Refer to Instruction Insert "**Field Painting and Finishing Fiberglass Or Steel Door Sections**".

Operation And Maintenance

OPERATING YOUR GARAGE DOOR:

Before you begin, read all warning labels affixed to the door and the installation instructions and owner's manual. When correctly installed, your Wayne Dalton door will operate smoothly. Always operate your door with controlled movements. Do not slam your door or throw your door into the open position, this may cause damage to the door or its components. If your door has an electric opener, refer to the owner's manual to disconnect the opener before performing manual door operation below.

Manual door operation:

For additional information on manual garage door operations go to www.dasma.com and reference TDS 165.

IMPORTANT: DO NOT PLACE FINGERS OR HANDS INTO SECTION JOINTS WHEN OPENING AND/OR CLOSING A DOOR. ALWAYS USE LIFT HANDLES / SUITABLE GRIPPING POINTS WHEN OPERATING THE DOOR MANUALLY.

Opening a Door: Make sure the lock(s) are in the unlocked position. Lift the door by using the lift handles / suitable gripping points only. Door should open with little resistance.

Closing a Door: From inside the garage, pull door downward using lift handles / gripping point only or a high friction area only. If you are unable to reach the lift handles/ suitable gripping points only, use pull down rope affixed to the side of door. Door should close completely with little resistance.

Using an electric operator:

IMPORTANT: PULL DOWN ROPES MUST BE REMOVED AND LOCKS MUST BE REMOVED OR MADE INOPERATIVE IN THE UNLOCKED POSITION.

When connecting a drawbar (trolley type) garage door operator to this door, a drawbar operator and or drawbar operator bracket must be securely attached to the top section of the door, along with any struts provided with the door. Always use the drawbar operator and or drawbar operator bracket supplied with the door. To avoid possible damage to your door, Wayne Dalton recommends reinforcing the top section on models 8000, 8100, 8200 and 9100 doors with a strut (may or may not be supplied). The installation of the drawbar operator must be according to manufacturer's instructions and force settings must be adjusted properly. Refer to the owner's manual supplied with your drawbar operator for complete details on installation, operation, maintenance and testing of the operator.

MAINTAINING YOUR GARAGE DOOR:

Before you begin, read all warning labels affixed to the door and the installation instructions and owner's manual. Perform routine maintenance steps once a month, and have the door professionally inspected once a year. Review your Installation Instructions and Owner's Manual for the garage door. These instructions are available at no charge from Wayne Dalton, A Division Of Overhead Door Corporation, P.O. Box 67, Mt. Hope, OH., 44660, or at www.Wayne-Dalton.com. For additional information on garage door/operator maintenance go to www.dasma.com and reference TDS 151, 167 and 179.

Monthly Inspections:

1. Visual Inspection: Closely inspect jambs, header and mounting surface. Any wood found not to be structurally sound must be replaced. Inspect the springs, counterbalance lift cables, track rollers, pulleys, rear back hangs and other door hardware for signs of worn or broken parts. Tighten any loose screws and/or bolts. Check exterior surface of the door sections for any minor cracks. Verify door has not shifted right or left in the opening. If you suspect problems, have a trained door system technician make the repairs.

WARNING

GARAGE DOOR SPRINGS, COUNTERBALANCE LIFT CABLES, BRACKETS, AND OTHER HARDWARE ATTACHED TO THE SPRINGS ARE UNDER EXTREME TENSION, AND IF HANDLED IMPROPERLY, CAN CAUSE SEVERE OR FATAL INJURY. ONLY A TRAINED DOOR SYSTEMS TECHNICIAN SHOULD ADJUST THEM, BY CAREFULLY FOLLOWING THE MANUFACTURER'S INSTRUCTIONS.

WARNING

NEVER REMOVE, ADJUST, OR LOOSEN THE BOLTS, SCREWS AND/OR LAG SCREWS ON THE COUNTERBALANCE (END OR CENTER BEARING BRACKETS) SYSTEM OR BOTTOM CORNER BRACKETS OF THE DOOR. THESE BRACKETS ARE CONNECTED TO THE SPRING(S) AND ARE UNDER EXTREME TENSION. TO AVOID POSSIBLE SEVERE OR FATAL INJURY, HAVE ANY SUCH WORK PERFORMED BY A TRAINED DOOR SYSTEMS TECHNICIAN USING PROPER TOOLS AND INSTRUCTIONS.

TorqueMaster® Plus Springs: Pawl knob(s) (located on the TorqueMaster® end brackets above the door) should be engaged to prevent the door from rapidly descending in case of spring failure or forceful manual operation.

Torsion Springs: The torsion springs (located above the door) should only be adjusted by a trained door systems technician. DO NOT attempt to repair or adjust torsion springs yourself.

Extension Springs: A restraining cable or other device should be installed on the extension spring (located above the horizontal tracks) to help contain the spring if it breaks.

2. Door Balance: Periodically test the balance of your door. If you have a garage door drawbar operator, use the release mechanism so you can operate the door by hand when doing this test. Start with the door in the fully closed position. Lift the door to check its balance. Adjust TorqueMaster® or Extension spring(s), if door lifts by itself (hard to pull down) or if door is difficult to lift (easy to pull down). DO NOT attempt to repair or adjust Torsion Springs yourself. To adjust TorqueMaster® or Extension spring(s), refer to your installation instructions and owner's manual. If in question about any of the procedures, do not perform the work. Instead, have it adjusted by a trained door systems technician.

3. Lubrication: The door should open and close smoothly. Ensure the door track rollers are rotating freely when opening and closing the door. If track rollers do not rotate freely, clean the door tracks, removing dirt and any foreign substances. Clean and lubricate (use a non-silicon based lubricant) graduated end hinges, center hinge(s), steel track rollers, bearings and torsion spring(s) (torsion spring coil surfaces). DO NOT lubricate plastic idler bearings, nylon track rollers, door track. DO NOT oil a cylinder lock, if actuation is difficult use a graphite dust to lubricate.

WARRANTY

Limited Warranty

Models 8000, 8100, 8200

Wayne Dalton, a division of Overhead Door Corporation (“Seller”) warrants to the original purchaser of the Models 8000, 8100, 8200 (“Product”), subject to all of the terms and conditions hereof, that the Product and all components thereof will be free from defects in materials and workmanship for the following period(s) of time, measured from the date of installation:

TEN (10) YEARS from the date of installation against:

- The Product becoming inoperable due to rust-through of the steel skin from the core of the Product section, due to cracking, splitting, or other deterioration of the steel skin, or due to structural failure caused by separation or degradation of the foam insulation.
- Peeling of the original paint as a result of a defect in the original paint or in the application of the original paint coating.

TEN (10) YEARS on Product hardware and tracks (except springs).

ONE (1) YEAR on all other component and parts.

Seller’s obligation under this warranty is specifically limited to repairing or replacing, at its option, any part which is determined by Seller to be defective during the applicable warranty period. Any labor charges are excluded and will be the responsibility of the purchaser.

This warranty gives you specific legal rights, and you may also have other rights which vary from state to state. This warranty is made to the original purchaser of the Product only, and is not transferable or assignable. This warranty applies only to Product installed in a residential or other non-commercial application. It does not cover any Product installed in commercial or industrial building applications. This warranty does not apply to any unauthorized alteration or repair of the Product, or to any Product or component which has been damaged or deteriorated due to misuse, neglect, accident, failure to provide necessary maintenance, normal wear and tear, acts of God, or any other cause beyond the reasonable control of Seller or as a result of having been exposed to toxic or abrasive environments, including blowing sand, salt water, salt spray and toxic chemicals and fumes.

ALL EXPRESS AND IMPLIED WARRANTIES FOR THE PRODUCT, INCLUDING BUT NOT LIMITED TO ANY IMPLIED WARRANTIES OF MERCHANTABILITY AND FITNESS FOR A PARTICULAR PURPOSE, ARE LIMITED IN TIME TO THE APPLICABLE WARRANTY PERIOD REFLECTED ABOVE. NO WARRANTIES, WHETHER EXPRESS OR IMPLIED, WILL APPLY AFTER THE LIMITED WARRANTY PERIOD HAS EXPIRED. Some states do not allow limitations on how long an implied warranty lasts, so the above limitation may not apply to you.

IN NO EVENT SHALL SELLER BE RESPONSIBLE FOR, OR LIABLE TO ANYONE FOR, SPECIAL, INDIRECT, COLLATERAL, PUNITIVE, INCIDENTAL OR CONSEQUENTIAL DAMAGES, even if Seller has been advised of the possibility of such damages. Such excluded damages include, but are not limited to, loss of use, cost of any substitute product, or other similar indirect financial loss. Some states do not allow the exclusion or limitation of incidental or consequential damages, so the above limitation or exclusion may not apply to you.

Claims under this warranty must be made promptly after discovery, within the applicable warranty period, and in writing to the authorized distributor or installer whose name and address appear below. The purchaser must allow Seller a reasonable opportunity to inspect any Product claimed to be defective prior to removal or any alteration of its condition. Proof of the purchase and/or installation date, and identification as the original purchaser, may be required. There are no established informal dispute resolution procedures of the type described in the Magnuson-Moss Warranty Act.

• SELLER: _____

• SELLER’S ADDRESS: _____

Thank you for your purchase.

PLEASE DO NOT RETURN THIS PRODUCT TO THE STORE

Please Do Not Return This Product To The Store. Please call 1-866-569-3799 (Press Option 1) and follow the prompts to contact the appropriate customer service agent. They will be happy to handle any questions that you may have.

**AFTER INSTALLATION IS COMPLETE, FASTEN THIS
MANUAL NEAR GARAGE DOOR FOR EASY REFERENCE.**