

Models 8000, 8100, 8200, 8300 and 8500

RESIDENTIAL DOORS

LOW HEADROOM (LHR)

QUICK START GUIDE / OWNER'S MANUAL

PLEASE DO NOT RETURN THIS PRODUCT TO THE STORE

If you need assistance, please call 1-866-569-3799 (press Option 1) and follow the prompts to contact a customer service representative. They will be happy to handle any questions that you may have.

**AFTER INSTALLATION IS COMPLETE,
LEAVE THIS QUICK START GUIDE /
OWNER'S MANUAL WITH THE
HOMEOWNER, OR FASTEN IT NEAR
GARAGE DOOR FOR EASY REFERENCE.**

Table Of Contents

Pre-Installation	2
Important Safety Instructions	2
Removing an Existing Door and Preparing the Opening	2
Tools Required	2
Breakdown of Door and Track Parts	4
Breakdown of (TM) and Extension Counterbalance Parts	5
Breakdown of Torsion Counterbalance Parts	6
Door Installation Instructions	7
Counterbalance Installation Instructions	15
TorqueMaster® Front Mount LHR	15
TorqueMaster® Rear Mount LHR	19
Torsion Front Mount LHR Inside Hookup	22
Torsion Front Mount LHR Outside Hookup	25
Torsion Rear Mount LHR Outside Hookup	28
Extension LHR	31
Maintenance	34
Cleaning Your Garage Door	34
Painting Your Garage Door	34
Maintaining The Finish On Your Garage Door	34
Operation And Maintenance	34
Warranty	36

QUICK START GUIDE IMPORTANT NOTICES!

This **Quick Start Guide / Owner's Manual** provides basic instructions for the installation of **standard-package** garage doors with a maximum door height of 8 feet only. Option-Specific Installation Instructions are available for doors over 8 feet tall, or purchased with any of the following options:

Riveted Track, Angle Mount Track, Windload, Standard Lift, High Lift, Full Vertical Lift, Roof Pitch, 32" Radius Track, Solid Shaft, Keyed Shafts, Center Coupler Assembly or any other option not included herein.

To avoid possible injury or damage, read and fully understand these instructions and any applicable Option-Specific Instructions carefully before installing and operating the garage door. Pay close attention to all warnings and notes.

The **Option-Specific Installation Instructions** and a more detailed **Installation Instructions And Owner's Manual** are available at no charge from:

- Your local Wayne Dalton Sales Center, or

- Online at www.Wayne-Dalton.com, or

- By mailing to: Wayne Dalton, a division of Overhead Door Corporation, P.O. Box 67, Mt. Hope, OH., 44660

Important Safety Instructions

DEFINITION OF KEY WORDS USED IN THIS MANUAL:

WARNING

INDICATES A POTENTIALLY HAZARDOUS SITUATION WHICH, IF NOT AVOIDED, COULD RESULT IN SEVERE OR FATAL INJURY.

CAUTION

INDICATES PROPERTY DAMAGE OR INJURY CAN RESULT FROM FAILURE TO FOLLOW INSTRUCTIONS.

IMPORTANT: INDICATES REQUIRED STEP FOR SAFE AND PROPER DOOR OPERATION.

NOTE: Indicates information assuring proper installation of the door.

READ THESE INSTRUCTIONS CAREFULLY BEFORE ATTEMPTING INSTALLATION. IF IN QUESTION ABOUT ANY OF THE PROCEDURES, DO NOT PERFORM THE WORK. INSTEAD, HAVE A TRAINED DOOR SYSTEMS TECHNICIAN DO THE INSTALLATION OR REPAIRS.

1. **READ AND FOLLOW ALL INSTALLATION INSTRUCTIONS.**
2. Wear protective gloves during installation to avoid cuts from sharp metal edges.
3. Wear eye protection when using tools, to avoid eye injury.
4. Do Not install your new door on a windy day. Door could fall during the installation, causing severe or fatal injury.
5. Doors 12'-0" wide and over must be installed by two persons, to avoid possible injury. Do Not attempt to install alone.
6. Operate door only when it is properly adjusted and free from obstructions.
7. If a door becomes hard to operate, inoperative or is damaged, immediately have necessary adjustments and/ or repairs made by a trained door system technician using proper tools and instructions.
8. DO NOT stand or walk under a moving door, or permit anybody to stand or walk under an electrically operated door.
9. DO NOT place fingers or hands into open section joints when closing a door. Use lift handles/ gripping points when operating door manually.
10. DO NOT permit children to operate garage door or door controls. Severe or fatal injury could result should the child become entrapped between the door and the floor.
11. Due to constant extreme spring tension, do not attempt any adjustment, repair or alteration to any part of the door, especially to springs, spring brackets, bottom corner brackets, fasteners, counterbalance lift cables or supports. To avoid possible severe or fatal injury, have any such work performed by a trained door systems technician using proper tools and instructions.
12. On electrically operated doors, pull down ropes must be removed and locks must be removed or made inoperative in the open (unlocked) position.
13. Top section of door may need to be reinforced when attaching an electric opener. Check door and/ or opener manufacturer's instructions.
14. Visually inspect door and hardware monthly for worn and or broken parts. Check to ensure door operates freely.
15. Test electric opener's safety features monthly, following manufacturer's instructions.
16. NEVER hang tools, bicycles, hoses, clothing or anything else from horizontal tracks. Track systems are not intended or designed to support extra weight.
17. This door may not meet the building code wind load requirements in your area. For your safety, you will need to check with your local building official for wind load code requirements and building permit information.
18. For windloaded doors, the wind performance is achieved via the entire door system and component substitution is not authorized without express permission by Wayne Dalton.

NOTE: It is recommended that 5/16" lag screws are pilot drilled using a 3/16" drill bit, prior to fastening.





CAUTION

IF ANY PART OF THE DOOR IS TO BE INSTALLED ONTO PRESERVATIVE-TREATED WOOD, PTFE-COATED OR STAINLESS STEEL FASTENERS MUST BE OBTAINED AND USED. REPLACEMENT FASTENERS MUST BE OF AT LEAST EQUAL STRENGTH AND SIZE AS ORIGINAL FASTENERS. IF THE ORIGINAL FASTENER WAS RED-HEAD, THE REPLACEMENT FASTENER MUST BE RED-HEAD ALSO. CONTACT WAYNE DALTON FOR FASTENER STRENGTH VALUES IF NEEDED.

WARNING

IMPACT GUNS ARE NOT RECOMMENDED. WHEN INSTALLING 5/16" LAG SCREWS USING AN ELECTRIC DRILL/ DRIVER, THE DRILL/ DRIVERS CLUTCH MUST BE SET TO DELIVER NO MORE THAN 200 IN-LBS OF TORQUE. FASTENER FAILURE COULD OCCUR AT HIGHER SETTINGS.

IMPORTANT: RIGHT AND LEFT HAND IS DETERMINED INSIDE THE BUILDING LOOKING OUT.

Potential Hazard	Effect	Prevention
 Moving door	 WARNING Could result in Death or Serious Injury	Keep people clear of opening while Door is moving. Do NOT allow children to play with the Door Opener. Do NOT operate a Door that jams or one that has a broken spring.
 High tension spring	 WARNING Could result in Death or Serious Injury	Do NOT try to remove, install, repair or adjust springs or anything to which door spring parts are fastened, such as, wood blocks, steel brackets, cables or other like items. Installations, repairs and adjustments must be done by a trained door system technician using proper tools and instructions.

Removing an Existing Door and Preparing the Opening

To avoid possible injury and to insure proper installation, it's highly recommended that you read and fully understand the complete instructions on removing an Existing Door & Preparing the Opening. These are available for download at www.Wayne-Dalton.com or at your local Wayne Dalton Sales Center.

NOTE: For complete details on the Headroom, Backroom or the Mounting Surface requirements, refer to more detailed Installation Instructions and Owner's manual available at www.Wayne-Dalton.com.

WEATHERSTRIPS (MAY NOT BE INCLUDED): Depending on the size of your door, you may have to cut or trim the weatherstrips (if necessary) to properly fit into the header and jambs.

NOTE: If nailing product at 40°F or below, pre-drilling is required.

NOTE: Do not permanently attach weatherstrips to the header and jambs at this time.

FOR QUICK INSTALL TRACK: For the header, align the weatherstrip with the inside edge of the header and temporarily secure it to the header with equally spaced nails. Starting at either side of the jamb, fit the weatherstrip up tight against the temporarily attached weatherstrip in the header and flush with the inside edge of the jamb. Temporarily secure the weatherstrip with equally spaced nails. Repeat for other side. This will keep the bottom section from falling out of the opening during installation. Equally space nails approximately 12" to 18" apart.

FOR FULLY ADJUSTABLE TRACK: For the header, align the weatherstrip 1/8" to 1/4" inside the header edge, and temporarily secure it to the header with equally spaced nails. Starting at either side of the jamb, fit the weatherstrip up tight against the temporarily attached weatherstrip in the header and 1/8" to 1/4" inside the jamb edge. Temporarily secure the weatherstrip with equally spaced nails. Repeat for other side. This will keep the bottom section from falling out of the opening during installation. Equally space nails approximately 12" to 18" apart.

Tools Required

Power drill	Phillips head screw-driver	Saw horses	Hammer
Drill bits: 1/8", 3/16", 9/32", 7/16", 1/2"	Wrenches: 3/8", 7/16", 1/2", 9/16", 5/8"	Needle nose pliers	Safety glasses
Ratchet wrench	Pencil	Pliers / Wire cutters	Level
Socket driver: 7/16"	Approved winding rods	Step ladder	Leather gloves
Sockets: 7/16", 1/2", 9/16", 5/8"	Locking pliers	Tape measure	Flat tip screwdriver

3" Ratchet extension	Vise clamps		
----------------------	-------------	--	--

BREAKDOWN OF DOOR AND TRACK PARTS

NOTE: The illustrations shown on this page are general representations of the door parts. Each specific door models may have unique variations.

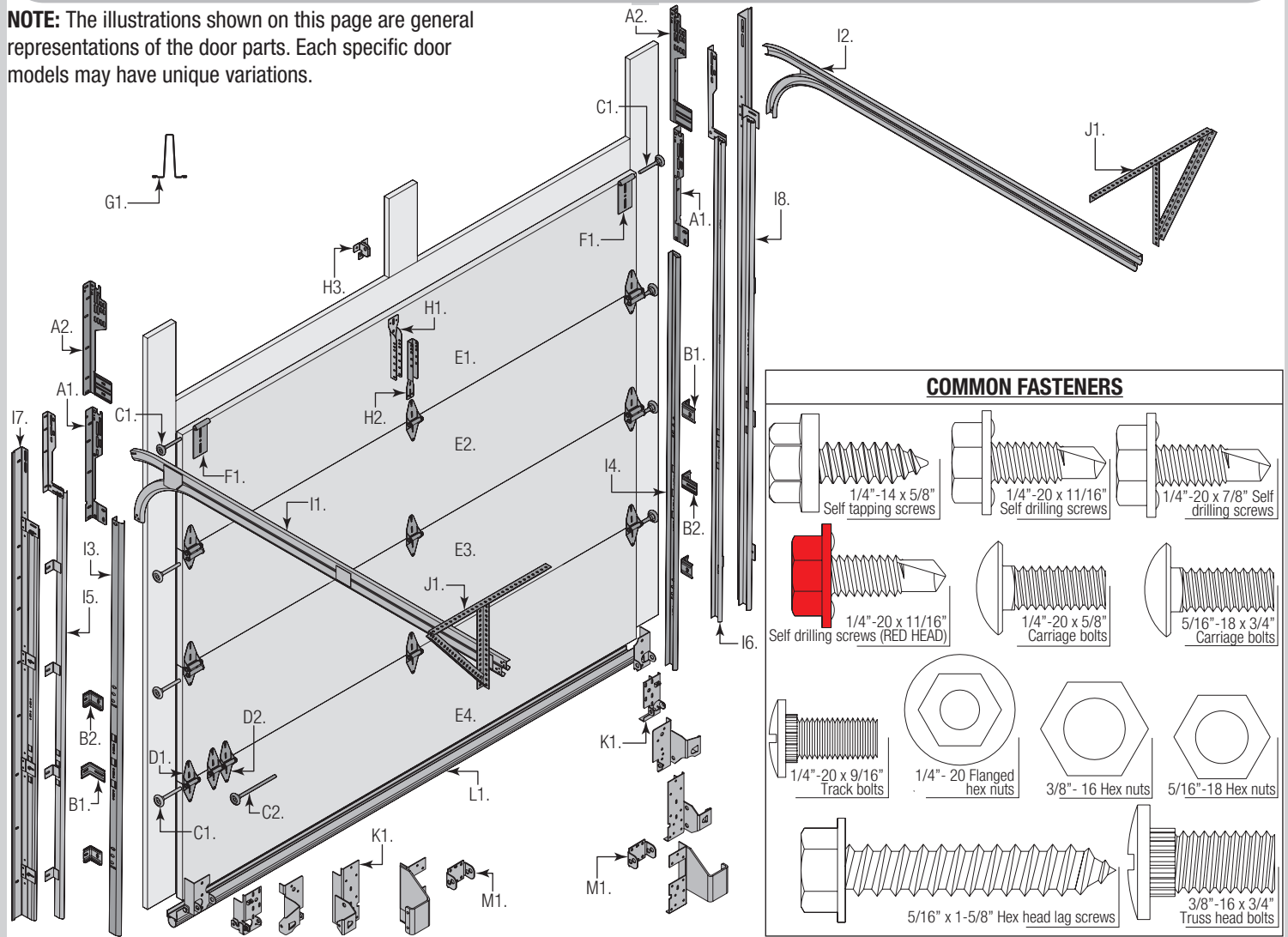

A. FLAG ANGLES (AS REQUIRED):

- A1. Quick Install (Q.I.) Flag Angles
- A2. Fully Adjustable (F.A.) Flag Angles

B. JAMB BRACKETS (AS REQUIRED):

- B1. Fully Adjustable (F.A.) Jamb Brackets
- B2. Quick Install (Q.I.) Jamb Brackets

C. TRACK ROLLERS (AS REQUIRED):

- C1. Short Stem Track Rollers
- C2. Long Stem Track Rollers

D. GRADUATED END HINGES (AS REQUIRED):

- D1. Single Graduated End Hinges (S.E.H.), Industry Standard
- D2. Double Graduated End Hinges (D.E.H.), Industry Standard

E. STACKED SECTIONS:

- E1. Top Section
- E2. Intermediate(s) Section
- E3. Lock Section / E4. Bottom Section

F. TOP FIXTURES (AS REQUIRED):

- F1. Top Fixtures

G. STRUT(S) (AS REQUIRED):

- G1. Strut (U - shaped)

H. DRAWBAR OPERATOR BRACKET (FOR TROLLEY OPERATED DOORS):

- H1. Top Halve Drawbar Operator Bracket - For Models 8300 / 8500
- H2. Bottom Halve Drawbar Operator Bracket - For Models 8300 / 8500
- H3. Drawbar Operator Bracket (Supplied By Others)

I. TRACKS (AS REQUIRED):

- I1. Left Hand Horizontal Track Assembly
- I2. Right Hand Horizontal Track Assembly
- I3. Left Hand Vertical Track
- I4. Right Hand Vertical Track
- I5. Left Hand Riveted Vertical Track Assembly
- I6. Right Hand Riveted Vertical Track Assembly
- I7. Left Hand Wall Angle Assembly
- I8. Right Hand Wall Angle Assembly

J. REAR BACK HANGS:

- J1. Left Hand And Right Hand Rear Back Hang Assemblies

K. BOTTOM CORNER BRACKETS (AS REQUIRED):

- K1. Left Hand and Right Hand Bottom Corner Brackets

L. BOTTOM WEATHER SEAL:

- L1. Bottom Weather Seal (Door Width)

M. TRACK ROLLER CARRIER'S (AS REQUIRED):

- M1. Track Roller Carrier's

BREAKDOWN OF (TM) AND EXTENSION COUNTERBALANCE PARTS

NOTE: The illustrations shown on this page are general representations of the door parts. Each specific door models may have unique variations.

Front Mount Low Headroom TorqueMaster® (TM) Springs

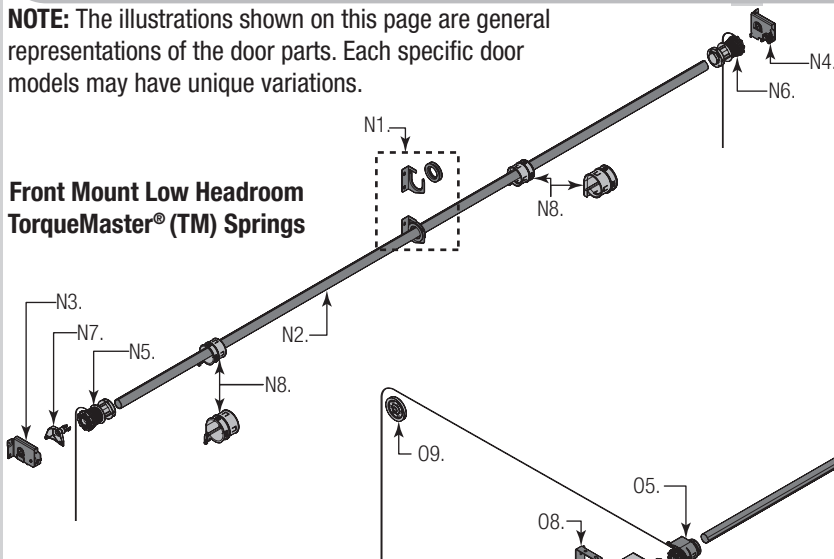

Rear Mount Low Headroom TorqueMaster® (TM) Springs

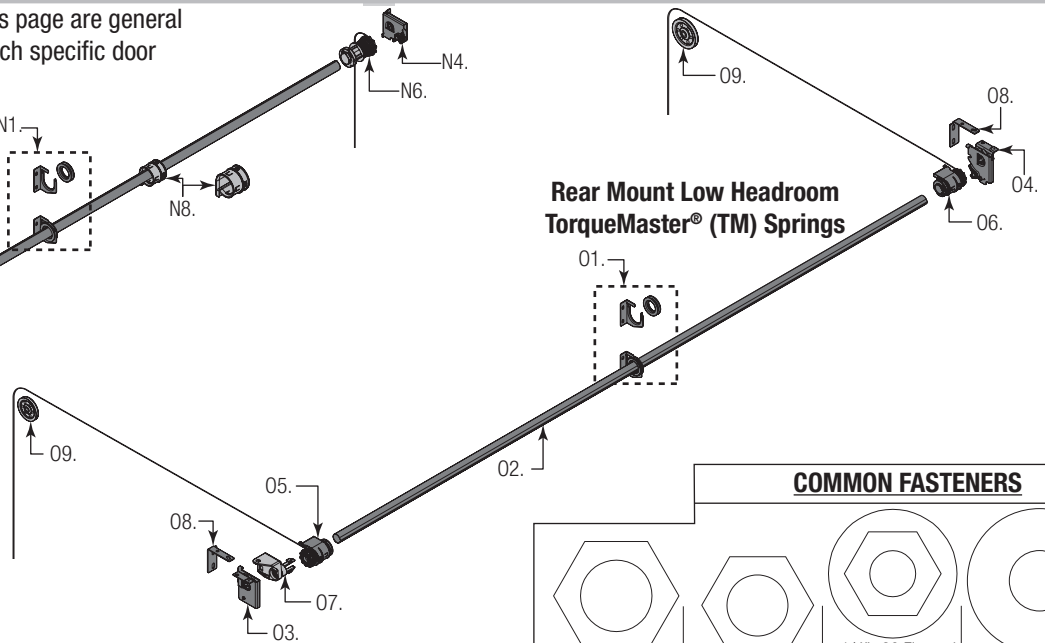

Low Headroom Extension Springs

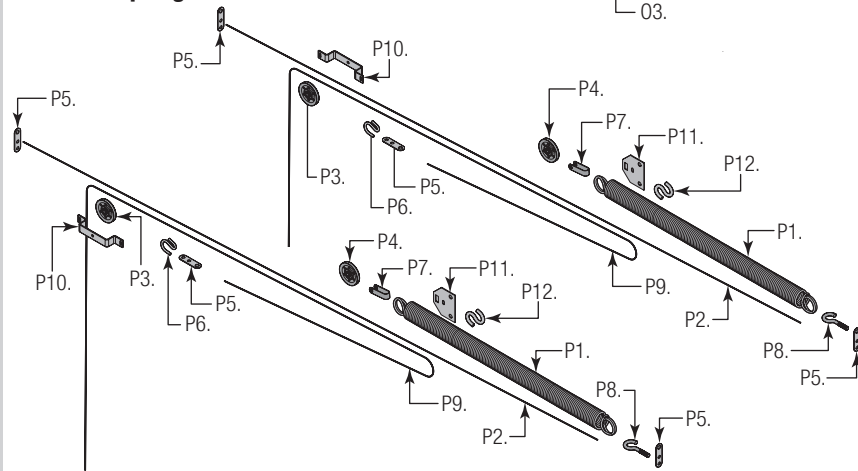

COMMON FASTENERS

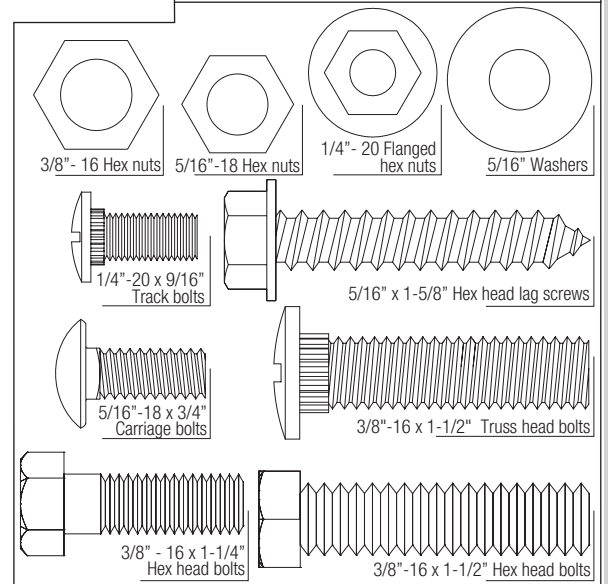

N. FRONT MOUNT LOW HEADROOM TORQUEMASTER PLUS® SPRING(S) COUNTERBALANCE APPLICATION:

- N1. Center Bracket Bushing Assembly
- N2. TorqueMaster® Spring Tube (Single Or Double Springs)
- N3. Left Hand End Bracket (Double Springs Only)
- N4. Right Hand End Bracket (Disconnect Cable Guide)
- N5. Left Hand Cable Drum Assembly
- N6. Right Hand Cable Drum Assembly
- N7. Idler bracket (Single Spring Only)
- N8. Left Hand And Right Hand Drum Wraps (Optional)

O. REAR MOUNT LOW HEADROOM TORQUEMASTER PLUS® SPRING(S) COUNTERBALANCE APPLICATION:

- O1. Center Bracket Bushing Assembly
- O2. TorqueMaster® Spring Tube (Single Or Double Springs)
- O3. Left Hand End Bracket (Double Springs Only)
- O4. Right Hand End Bracket (Disconnect Cable Guide)
- O5. Left Hand Cable Drum Assembly
- O6. Right Hand Cable Drum Assembly
- O7. Idler bracket (Single Spring Only)
- O8. Reinforcing Brackets (If Included)
- O9. Cable Lift Sheaves

P. LOW HEADROOM EXTENSION SPRING COUNTERBALANCE APPLICATION:

- P1. Extension Springs
- P2. Spring Restraint Cables
- P3. Front Cable Lift Sheaves
- P4. Rear Cable Lift Sheaves
- P5. 3 Hole Clips (As Required)
- P6. Small S-Hooks (As Required)
- P7. Sheave Forks (As Required)
- P8. 5/16" - 18 x 3-3/4" Eye Bolts (As Required)
- P9. Counterbalance Lift Cables
- P10. Sheave Saddles (As Required)
- P11. Hook Plates (As Required)
- P12. Large S-Hooks (As Required)

BREAKDOWN OF TORSION COUNTERBALANCE PARTS

NOTE: The illustrations shown on this page are general representations of the door parts. Each specific door models may have unique variations.

Front Mount Low Headroom Inside Hook-up Torsion Springs

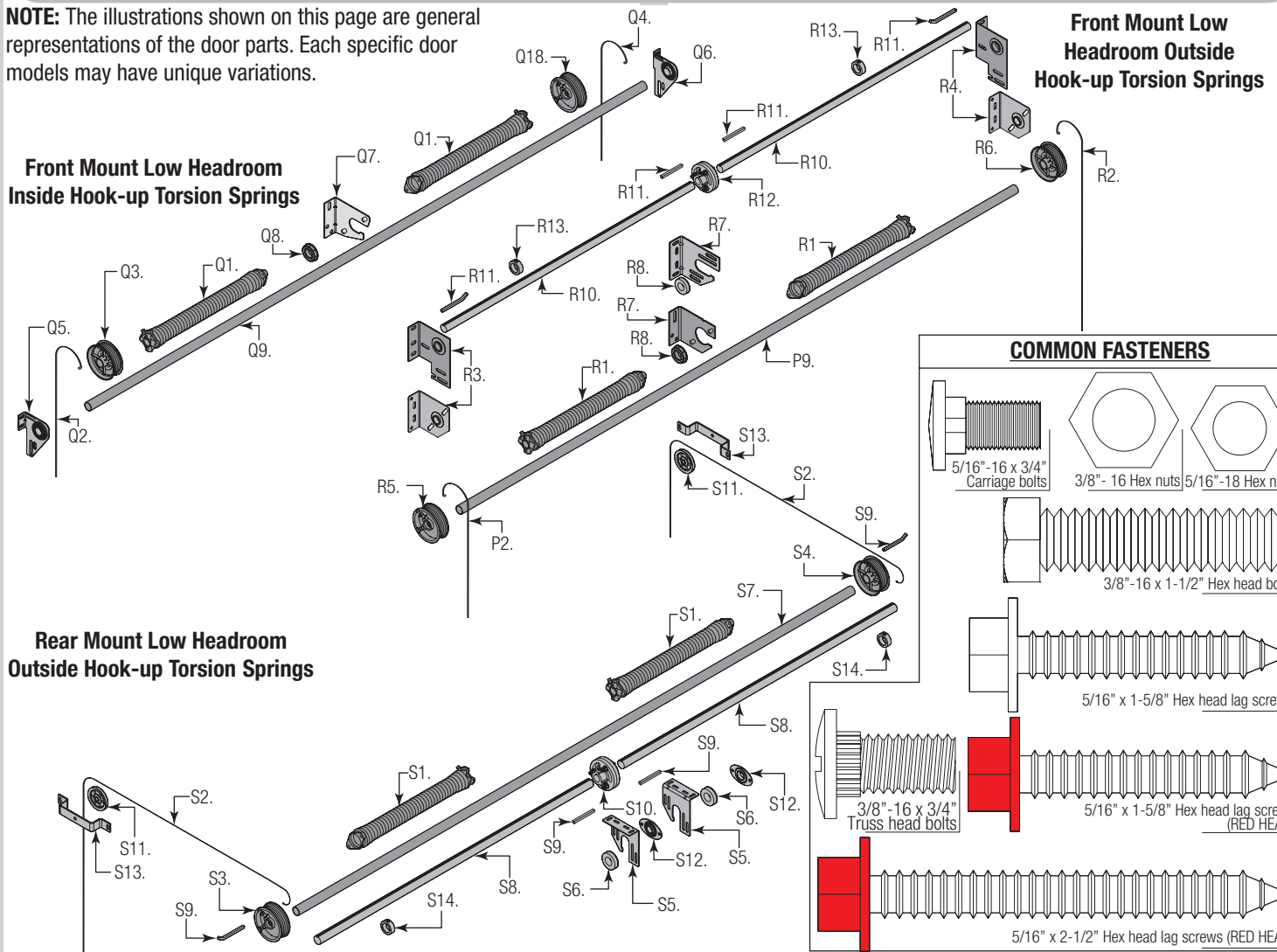

Front Mount Low Headroom Outside Hook-up Torsion Springs

COMMON FASTENERS

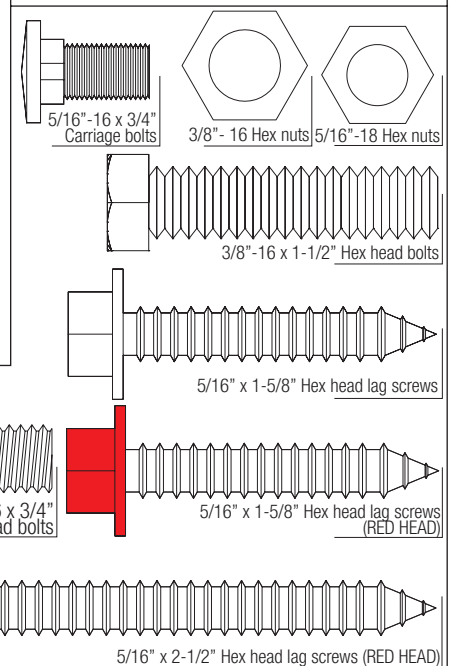

Q. FRONT MOUNT LOW HEADROOM INSIDE HOOK-UP, TORSION SPRING COUNTERBALANCE APPLICATION:

- Q1. Left Hand and Right Hand Torsion Springs (As Required)
- Q2. Counterbalance Lift Cables
- Q3. Left Hand End Bearing Bracket
- Q4. Right Hand End Bearing Bracket
- Q5. Left Hand Cable Drum
- Q6. Right Hand Cable Drum
- Q7. Center Bracket
- Q8. Center Bracket Bearing
- Q9. Torsion Shaft

R. FRONT MOUNT LOW HEADROOM OUTSIDE HOOK-UP, TORSION SPRING COUNTERBALANCE APPLICATION:

- R1. Left Hand and Right Hand Torsion Springs (As Required)
- R2. Counterbalance Lift Cables
- R3. Left Hand End Bearing Brackets (As Required)
- R4. Right Hand End Bearing Brackets (As Required)
- R5. Left Hand Cable Drum
- R6. Right Hand Cable Drum
- R7. Center Bracket (As Required)
- R8. Center Bracket Bearing
- R9. Torsion Shaft / Torsion Keyed Shaft (As Required)
- R10. Torsion Keyed Shafts (As Required)
- R11. Keys (As Required)
- R12. Center Coupler Assembly (As Required)

S. REAR MOUNT LOW HEADROOM OUTSIDE HOOK-UP, TORSION SPRING COUNTERBALANCE APPLICATION:

- S1. Left Hand and Right Hand Torsion Springs (As Required)
- S2. Counterbalance Lift Cables
- S3. Left Hand Cable Drum
- S4. Right Hand Cable Drum
- S5. Center Bracket (As Required)
- S6. Center Bracket Bearing
- S7. Torsion Shaft / Torsion Keyed Shaft (As Required)
- S8. Torsion Keyed Shafts (As Required)
- S9. Keys (As Required)
- S10. Center Coupler Assembly (As Required)
- S11. Cable Lift Sheaves
- S12. Oval Bearings (As Required)
- S13. Sheave Saddles (As Required)
- S14. Set Collars (As Required)

DOOR INSTALLATION INSTRUCTIONS

To avoid possible injury and to insure proper installation, it's highly recommend that you read and fully understand the complete **Installation Instructions and Owner's Manual** and any applicable **Option-Specific Installation Instructions** before you attempt this installation. The complete **Option-Specific Installation Instructions and owner's manual** are available for download at www.Wayne-Dalton.com.

IMPORTANT: FOR MORE DETAILED INFORMATION ON COMPONENTS AND INSTALLATION STEPS, REFER TO THE COMPLETE INSTALLATION INSTRUCTIONS AND OWNER'S MANUAL AVAILABLE AT WWW.WAYNE-DALTON.COM.

NOTE: Reference TDS 160 for general garage door terminology at www.dasma.com.

IMPORTANT: IF THE DOOR WILL BE EXPOSED TO A SIGNIFICANT AMOUNT OF ROAD SALT, PAINT THE BARE GALVANIZED BOTTOM WEATHER STEEL RETAINER TO INHIBIT RUSTING.

1

Attaching Flag Angles and Jamb Brackets To Vertical Tracks

Tools Required: Tape measure, Safety glasses, Leather gloves

NOTE: If you have Riveted Track or Angle Mount Track, skip this step.

FOR DOORS WITH QUICK INSTALL TRACK:

For Door Models 8000, 8100 and 8200, Jamb Bracket Schedule

DOOR HEIGHT	VERTICAL TRACK LENGTH	1ST SET		2ND SET		3RD SET	
		JAMB BKT	POSITION	JAMB BKT	POSITION	JAMB BKT	POSITION
6'0"	58-3/4"	9	M	11	M	N/A	
6'3"	62"	9	B	11	M	N/A	
6'6" - 7'0"	65-1/4" - 70"	9	M	10	B	N/A	
7'6" - 8'0"	76-1/2" - 82-1/2"	9	T	10	M	11	M

B= BOTTOM HOLE, M= MIDDLE HOLE, T= TOP HOLE

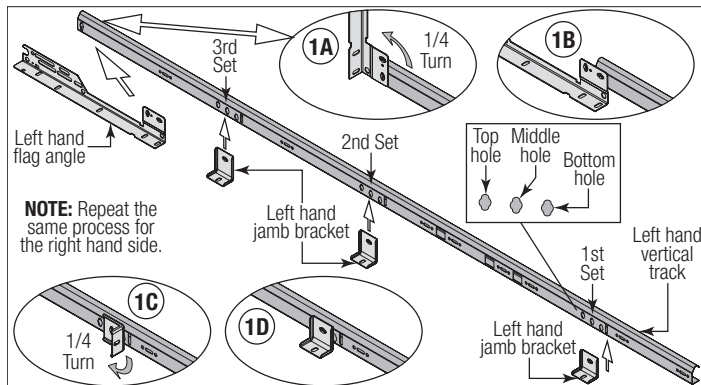

FOR DOORS WITH FULLY ADJUSTABLE TRACK:

First measure the radius of your horizontal track:

For 15" radius track

For 12" radius track

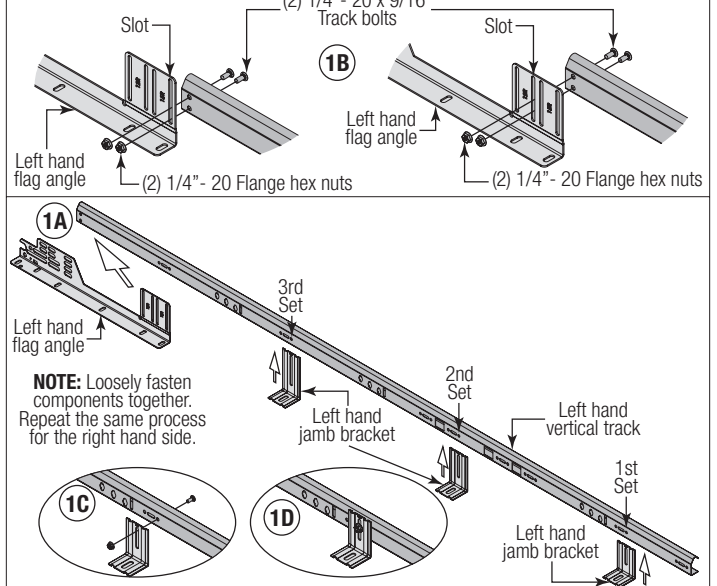

2

Attaching Bottom Weather Seal

Tools Required: Power drill, 7/16" Socket driver, Tape measure, Saw Horses, Safety glasses, Leather gloves

NOTE: If you did not receive a bottom weather seal, skip this step.

NOTE: Verify that the bottom weather seal is aligned with bottom section. If needed, trim the bottom weather seal even with bottom section length.

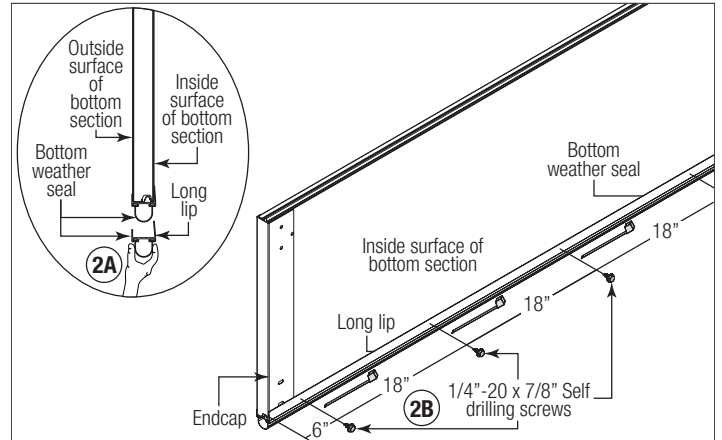

3

Attaching Bottom Corner Brackets

Tools Required: Power drill, 7/16" Socket driver, Tape measure, Level, Safety glasses, Leather gloves

⚠ WARNING

ENSURE TIGHT FIT OF CABLE LOOP OVER MILFORD / CLEVIS PIN TO PREVENT COUNTERBALANCE LIFT CABLE FROM COMING OFF THE PIN, WHICH COULD ALLOW THE DOOR TO FALL AND RESULT IN SEVERE OR FATAL INJURY.

NOTE: If your door has TorqueMaster® Plus counterbalance, the cable drum assemblies are marked right and left hand.

NOTE: Check to ensure cable loop fits tightly over the milford pins.

NOTE: Verify bottom weather seal (bottom seal) is aligned with door section. If there is more than 1/2" excess bottom weather seal on either side, trim bottom weather seal even with door section.

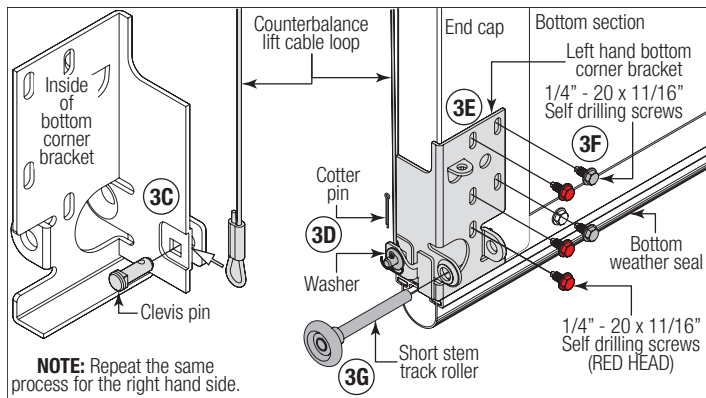
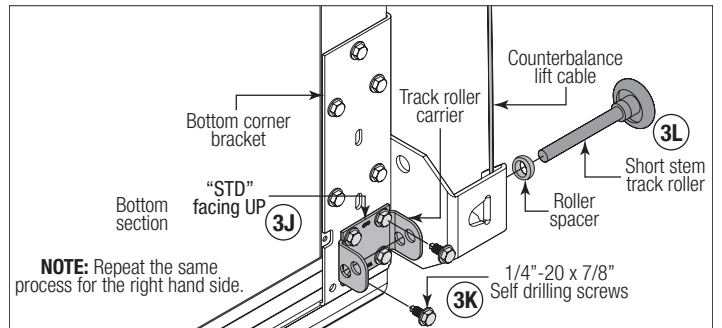
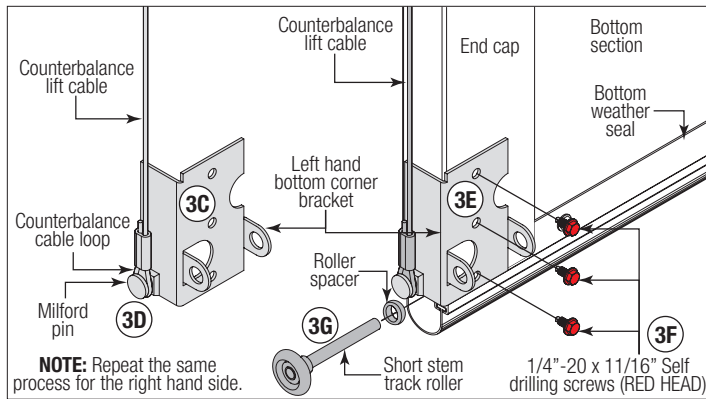
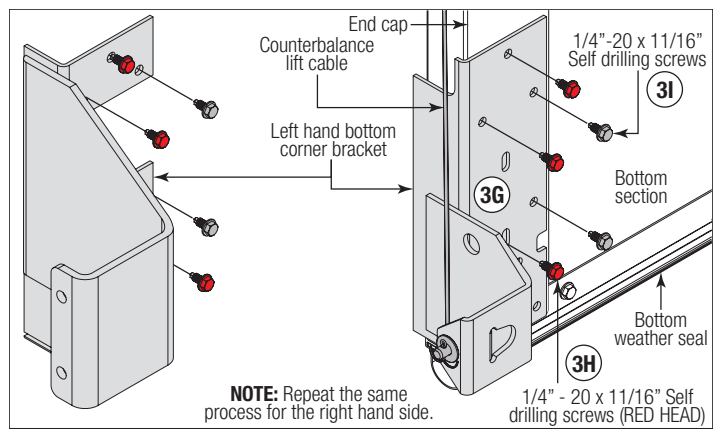
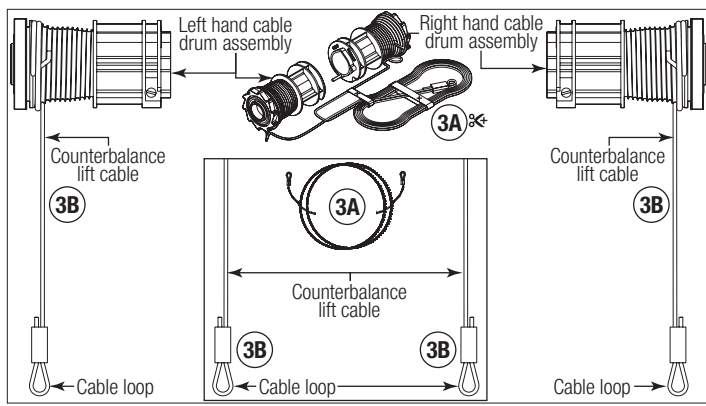

4 Attaching Hinges and Strut(s) To Sections

Tools Required: Power drill, 7/16" Socket driver, Tape measure, Level, Step ladder, Safety glasses, Leather gloves

NOTE: The graduated hinges can be identified by the number stamped on the lower hinge leaf.

NOTE: The #1 graduated end hinges serves as end hinges on the bottom section. The #1 graduated end hinges also serves as center hinges on all sections, except for the top section.

NOTE: The #2 graduated end hinges serves as end hinges on the Lock section.

NOTE: The #3 graduated end hinges serves as end hinges on the Intermediate I section.

NOTE: The #4 graduated end hinges serves as end hinges on the Intermediate II section.

NOTE: The #5 graduated end hinges serves as end hinges on the Intermediate III section.

NOTE: The #6 graduated end hinges serves as end hinges on the Intermediate IV section.

NOTE: The #7 graduated end hinges serves as end hinges on the Intermediate V section.

NOTE: The #8 graduated end hinges serves as end hinges on the Intermediate VI section.

IMPORTANT: ONCE THE 1/4" - 14 X 5/8" SELF TAPPING SCREWS ARE SNUG AGAINST THE LOWER HINGE LEAVES, TIGHTEN AN ADDITIONAL 1/4 TO 1/2 TURN TO RECEIVE MAXIMUM DESIGN HOLDING POWER.

Repeat graduated hinge attachment using the appropriate graduated end hinges for all remaining sections except the top section.

IMPORTANT: WHEN PLACING SHORT STEM TRACK ROLLERS INTO THE #2 GRADUATED END HINGES AND HIGHER, THE SHORT STEM TRACK ROLLER GOES INTO HINGE TUBE FURTHEST AWAY FROM SECTION.

NOTE: Refer to the strutting schedules below to determine the placement of strut(s) on your door. Be sure to use the proper schedules for the type of door model and the size of your door.

IMPORTANT: WHEN REFERRING TO THE STRUTTING SCHEDULES, DETERMINE HOW MANY STRUTS YOUR DOOR NEEDS AND ON WHAT SECTIONS THEY ARE NEEDED TO BE INSTALLED. ALSO BE SURE TO USE THE CORRECT STRUTTING SCHEDULE FOR ALUMINUM DOORS OR STEEL DOORS DEPENDING ON THE MATERIAL YOUR DOOR IS MADE OF. ALSO USE THE CORRECT STRUTTING SCHEDULE FOR THE PROPER COLOR OF YOUR DOOR.

NOTE: Sections not noted in the strutting schedule, do not require a strut. All strut(s) are placed at the top of the section(s).

NOTE: If you paint your door models 8300 or 8500, follow the Strutting Schedule For Brown, Black and Woodgrain Colored Doors.

FOR DOOR MODELS 8000 / 8100 / 8200:

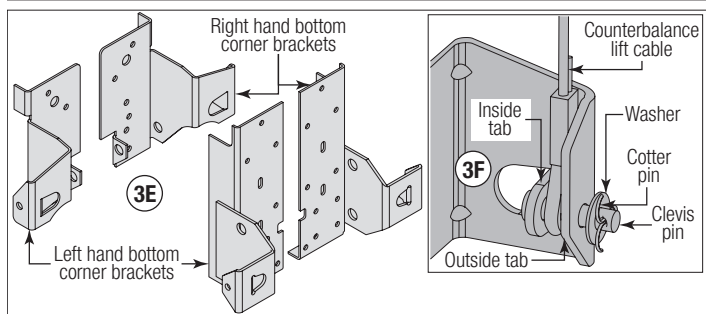

NOTE: Depending on your door some sections may or may not require a strut to be installed onto the section.

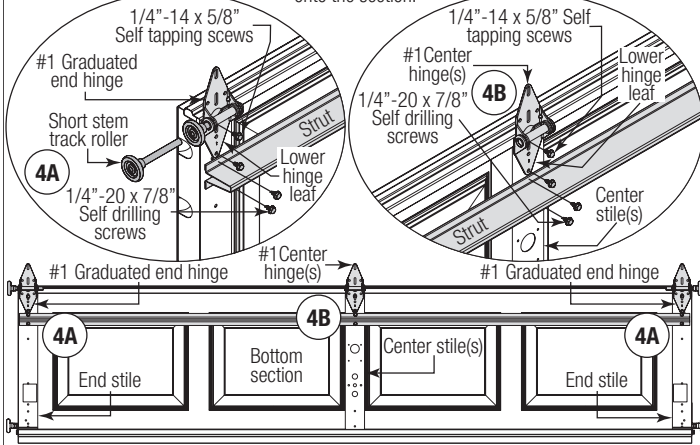

NOTE: Depending on your door some sections may or may not require a strut to be installed onto the section.

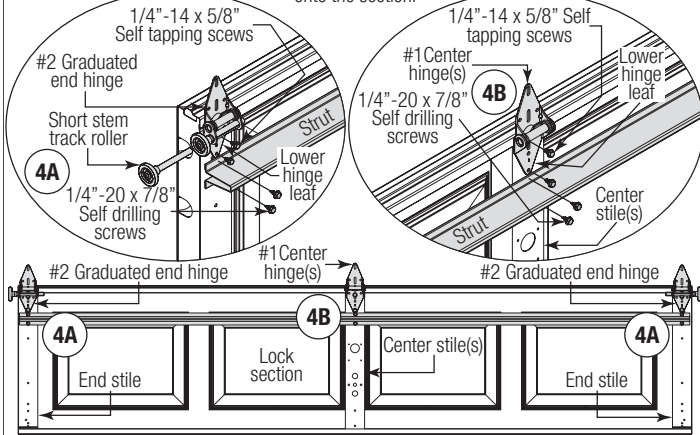

NOTE: Depending on your door some sections may or may not require a strut to be installed onto the section.

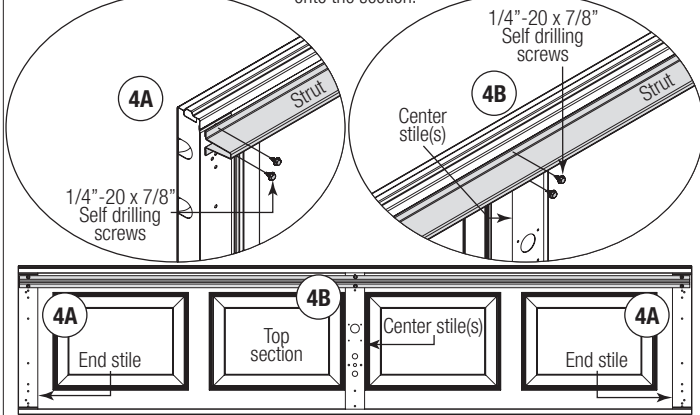

FOR DOOR MODELS 8300 / 8500:

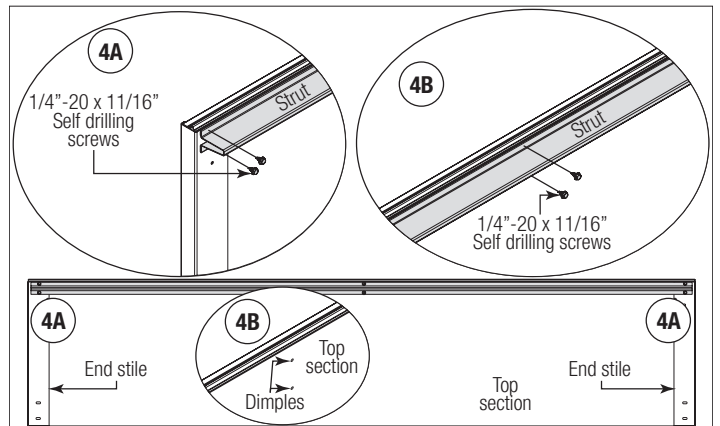
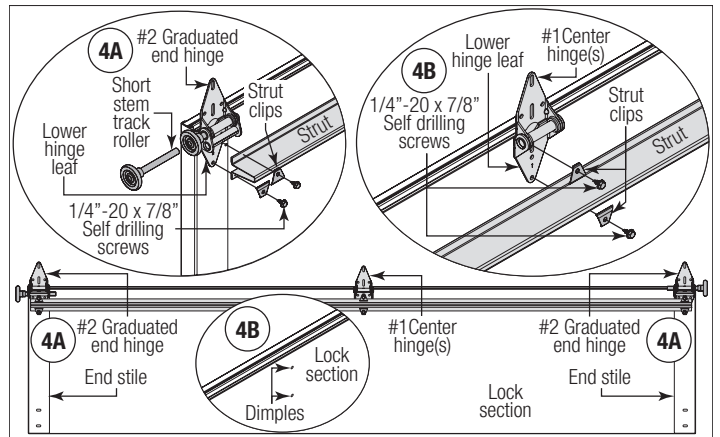
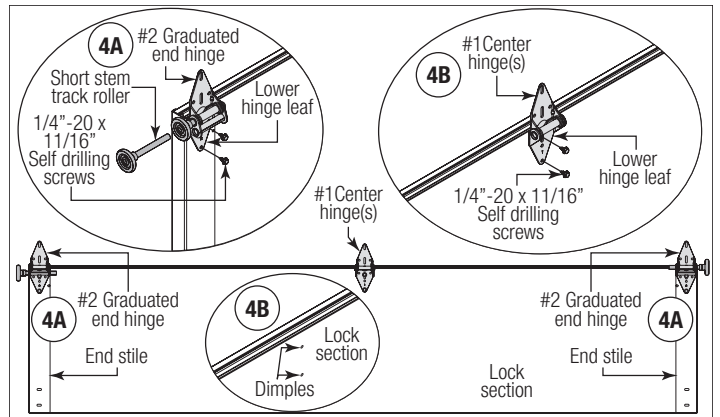
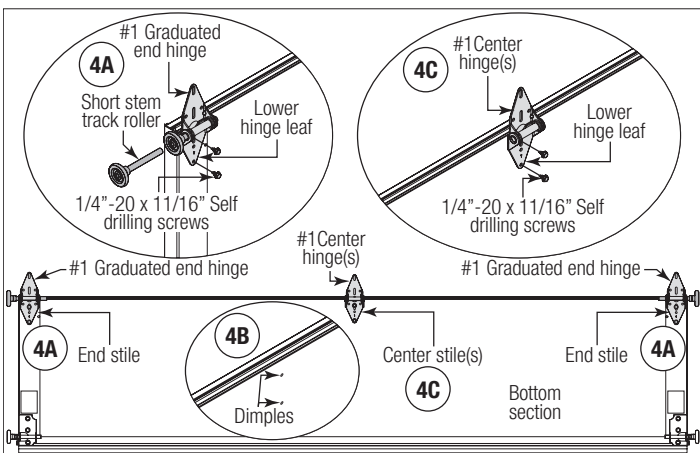

Strutting Schedule Key:

TS = Top Section	I4 = Intermediate Section #4	LS = Lock Section
IW = Intermediate Section With Windows	I3 = Intermediate Section #3	BS = Bottom Section
I6 = Intermediate Section #6	I2 = Intermediate Section #2	ES = Every Section gets a strut.
I5 = Intermediate Section #5	I1 = Intermediate Section #1	RS = Remaining Sections gets a strut.

Strutting Schedule For Models 8000 and 8100

Door Heights	Section Qty	Section Type	Door Widths		
			14'0" - 16'0"	17'0" - 18'0"	20'0"
6'0" - 7'0"	4	Solid	(1) TS	(3) TS, LS, BS	ES
		Windows	(1) TS	(1) 3" TS, (2) 2" LS, BS	ES
7'6" - 8'9"	5	Solid	(2) TS, BS	(3) TS, I1, BS	ES
		Windows	(1) 3" TS, (1) 2" BS	(1) 3" TS, (2) 2" I1, BS	ES

Strutting Schedule For Models 8000 and 8100					
Door Heights	Section Qty	Section Type	Door Widths		
			14'0" - 16'0"	17'0" - 18'0"	20'0"
9'0" - 10'6"	6	Solid	(5) TS, I3, I2, I1, BS	ES	N/A
		Windows	(1) 3" TS, (4) 2" I3, I2, I1, BS	(1) 3" TS, (5) 2" RS	N/A
10'9" - 12'3"	7	Solid	(6) TS, I4, I3, I2, I1, BS	N/A	
		Windows	(1) 3" TS, (5) 2" I4, I3, I2, I1, BS	N/A	
12'6" - 14'0"	8	Solid	(7) TS, I5, I4, I3, I2, I1, BS	N/A	
		Windows	(1) 3" TS, (6) 2" I5, I4, I3, I2, I1, BS	N/A	

Strutting Schedule For Model 8200					
Door Heights	Section Qty	Section Type	Door Widths		
			14'0" - 16'0"	14'0" - 16'0"	14'0" - 16'0"
6'0" - 7'0"	4	Solid	(2) TS, BS	(3) TS, LS, BS	ES
		Windows	(1) 3" TS, (1) 2" BS	(1) 3" TS, (2) 2" LS, BS	ES
7'6" - 8'0"	5	Solid	(2) TS, BS	(3) TS, I1, BS	ES
		Windows	(1) 3" TS, (1) 2" BS	(1) 3" TS, (2) 2" I1, BS	ES
8'3" - 8'9"	5	Solid	(2) TS, BS	(3) 2" TS, I1, BS	N/A
		Windows	(1) 3" TS, (1) 2" BS	(1) 3" TS, (2) 2" I1, BS	N/A
9'0" - 10'6"	6	Solid	(5) TS, I3, I2, I1, BS	ES	N/A
		Windows	(1) 3" TS, (4) 2" I3, I2, I1, BS	(1) 3" TS, (5) 2" RS	N/A
10'9" - 12'3"	7	Solid	(6) TS, I4, I3, I2, I1, BS	N/A	
		Windows	(1) 3" TS, (5) 2" I4, I3, I2, I1, BS	N/A	
12'6" - 14'0"	8	Solid	(7) TS, I5, I4, I3, I2, I1, BS	N/A	
		Windows	(1) 3" TS, (6) 2" I5, I4, I3, I2, I1, BS	N/A	

Strutting Schedule For Model 8300 Steel (White, Almond and Taupe Colored Doors)						
Door Heights	Section Qty	Section Type	Door Widths			
			9'1" - 14'0"	14'1" - 16'0"	16'1" - 18'0"	18'1" - 20'0"
<= 8'3"	4	Solid	(1) TS	(2) TS, LS	(3) TS, LS, BS	ES
		Top (Windows)	(1) TS	(2) TS, LS	(1) 3" TS, (2) 2" LS, BS	ES
		Intermediate (Windows)	(2) TS, IW	(3) TS, IW, BS		ES
	5	Solid	(1) TS	(2) TS, I1	(3) TS, I1, BS	ES
		Top (Windows)	(1) TS	(2) TS, I1	(1) 3" TS, (2) 2" I1, BS	ES
		Intermediate (Windows)	(2) TS, IW	(3) TS, IW, BS		ES

Strutting Schedule For Model 8300 Steel (White, Almond and Taupe Colored Doors)						
Door Heights	Section Qty	Section Type	Door Widths			
			9'1" - 14'0"	14'1" - 16'0"	16'1" - 18'0"	18'1" - 20'0"
8'4" - 12'0"	5	Solid	(1) TS	(3) TS, I1, BS	ES	N/A
		Top (Windows)	(1) TS	(3) TS, I1, BS	(1) 3" TS, (4) 2" RS	N/A
		Intermediate (Windows)	(2) TS, IW	(3) TS, IW, BS	ES	N/A
	6	Solid	(1) TS	(3) TS, I2, BS	ES	N/A
		Top (Windows)	(1) TS	(3) TS, I2, BS	(1) 3" TS, (5) 2" RS	N/A
		Intermediate (Windows)	(2) TS, IW	(3) TS, IW, BS	ES	N/A
12'0" - 14'0"	7 sections for 14'0" high RP	Solid	(1) TS	(1) 3" TS, (3) 2" I3, I1, BS	(1) 3" TS, (3) 2" I3, I1, BS	N/A
	9 sections for 14'0" high Elongation	Top (Windows)	(1) TS	(1) 3" TS, (3) 2" I3, I1, BS	(1) 3" TS, (5) 2" I4, I3, I2, I1, BS	N/A
		Intermediate (Windows)	(2) TS, IW	(1) 3" TS, (3) 2" IW, I1, BS	(1) 3" TS, (5) 2" IW, I3, I2, I1, BS	N/A

Strutting Schedule For Model 8300 Steel (Brown, Black and Woodgrain Colored Doors)							
Door Heights	Section Qty	Section Type	Door Widths				
			9'1" - 10'0"	10'1" - 16'0"	16'1" - 18'0"	18'1" - 20'0"	
<= 8'3"	4	Solid / Top (Windows)	(2) TS, I1	(3) TS, LS, BS		ES	
		Intermediate (Windows)	(2) TS, IW	(3) TS, IW, BS		ES	
	5	Solid / Top (Windows)	(2) TS, I1	(3) TS, I1, BS		ES	
		Intermediate (Windows)	(2) TS, IW	(3) TS, IW, BS		ES	
	8'4" - 12'0"	5	Solid / Top (Windows)	(2) TS, I1	(3) TS, I1, BS	ES	N/A
			Intermediate (Windows)	(2) TS, IW	(3) TS, IW, BS	ES	N/A
6		Solid / Top (Windows)	(2) TS, I1	(3) TS, I2, BS	ES	N/A	
		Intermediate (Windows)	(2) TS, IW	(3) TS, IW, BS	ES	N/A	
12'0" - 14'0"	7 sections for 14' high RP	Solid / Top (Windows)	(2) TS, I1	(1) 3" TS, (4) 2" I3, I1, LS, BS	ES	N/A	
	9 sections for 14' high Elongation	Intermediate (Windows)	(2) TS, IW	(1) 3" TS, (4) 2" IW, I1, LS, BS	ES	N/A	

Strutting Schedule For Model 8300 Aluminum (White, Almond and Taupe Colored Doors)							
Door Heights	Section Qty	Section Type	Door Widths				
			6' 1" - 9' 0"	10' 1" - 14' 0"	15' 0" - 16' 0"	17' 0" - 18' 0"	20' 0"
<= 8' 0"	4 Or 5	Solid	(1) TS		(3) TS, I1, BS		(1) 3", Per Section, No strut on lock for 5 section 8' high
		Top (Windows)	(1) TS		(3) TS, I1, BS	(1) 3" TS, (2) 2" LS, BS	(1) 3", Per Section, No strut on lock for 5 section 8' high
		Intermediate (Windows)	(1) TS	(2) TS, IW	(3) TS, IW, BS		(1) 3", Per Section, No strut on lock for 5 section 8' high
> 8' 0"	4 Or 5	Solid	(1) TS		(4) TS, I2, I1, BS	ES	N/A
		Top (Windows)	(1) TS		(4) TS, I2, I1, BS	(1) 3" TS, (1) 2" RS	N/A
		Intermediate (Windows)	(1) TS	(2) TS, IW	(2) TS, IW, I1, BS	ES	N/A

Strutting Schedule For Model 8300 Aluminum (Brown, Black and Woodgrain Colored Doors)						
Door Heights	Section Qty	Section Type	Door Widths			
			6' 1" - 10' 0"	12' 0" - 16' 0"	17' 0" - 18' 0"	20' 0"
<= 8' 0"	4 Or 5	Solid Or Windows	(1) TS	(3) TS, LS, BS		ES
> 8' 0"	4 Or 5	Solid Or Windows	(1) TS	(4) TS, I1, LS, BS	ES	N/A

Strutting Schedule For Model 8500 Steel (White, Almond and Taupe Colored Doors)							
Door Heights	Section Qty	Section Type	Door Widths				
			<= 9' 0"	9' 1" - 10' 0"	10' 1" - 14' 0"	14' 1" - 16' 0"	16' 1" - 18' 0"
<= 8' 0"	4	Solid	N/A		(1) TS	(3) TS, LS, BS	ES
		Top (Windows)	N/A	(1) TS		(1) 3" TS, (2) 2" LS, BS	ES
		Intermediate (Windows)	N/A		(2) TS, IW	(3) TS, IW, BS	
	5	Solid	N/A		(1) TS	(3) 2" TS, I1, BS	ES
		Top (Windows)	N/A	(1) TS		(1) 3" TS, (2) 2" I1, BS	ES
		Intermediate (Windows)	N/A		(2) TS, IW	(3) TS, IW, BS	

Strutting Schedule For Model 8500 Steel (White, Almond and Taupe Colored Doors)								
Door Heights	Section Qty	Section Type	Door Widths					
			<= 9' 0"	9' 1" - 10' 0"	10' 1" - 14' 0"	14' 1" - 16' 0"	16' 1" - 18' 0"	18' 1" - 20' 0"
> 8' 0"	5	Solid	N/A		(1) TS	(3) TS, I1, BS	(4) TS, I2, I1, BS	N/A
		Top (Windows)	N/A	(1) TS		(3) TS, I1, BS	(1) 3" TS, (3) 2" I2, I1 & BS	N/A
		Intermediate (Windows)	N/A		(2) TS, IW	(3) TS, IW, BS	(4) TS, IW, I1, BS	N/A
	6	Solid	N/A		(1) TS	(2) TS, I2	(4) TS, I2, I1, BS	N/A
		Top (Windows)	N/A	(1) TS		(2) TS, I2	(1) 3" TS, (3) 2" I2, I1, BS	N/A
		Intermediate (Windows)	N/A		(2) TS, IW	(3) TS, IW, BS	(4) TS, IW, I1, BS	N/A
12' 0" - 14' 0"	7 sections for 14' 0" high RP	Solid	N/A		(1) TS	(4) TS, I3, I1, BS	(1) 3" TS, (4) 2" I4, I3, I1, BS	N/A
		Top (Windows)	N/A	(1) TS		(4) TS, I3, I1, BS	(1) 3" TS, (4) 2" I4, I3, I1, BS	N/A
		Intermediate (Windows)	N/A		(2) TS, IW	(4) TS, IW, I1, BS	(1) 3" TS, (4) 2" IW, I3, I1, BS	N/A

Strutting Schedule For Model 8500 Steel (Brown, Black and Woodgrain Colored Doors)							
Door Heights	Section Qty	Section Type	Door Widths				
			9' 1" - 10' 0"	10' 1" - 16' 0"	16' 1" - 18' 0"	18' 1" - 20' 0"	
<= 8' 0"	4	Solid / Top (Windows)	(1) TS	(3) TS, LS, BS		ES	
		Intermediate (Windows)	(1) TS	(3) TS, IW, BS		ES	
	5	Solid / Top (Windows)	(1) TS	(3) TS, I1, BS		ES	
		Intermediate (Windows)	(1) TS	(3) TS, IW, BS		ES	
	> 8' 0"	5	Solid / Top (Windows)	(1) TS	(4) TS, I2, I1, BS		N/A
			Intermediate (Windows)	(1) TS	(4) TS, IW, I1, BS		N/A
6		Solid / Top (Windows)	(1) TS	(4) TS, I2, I1, BS		N/A	
		Intermediate (Windows)	(2) TS, IW	(4) TS, IW, I1, BS		N/A	
12' 0" - 14' 0"	7 sections for 14' 0" high RP 9 sections for 14' 0" high Elongation	Solid / Top (Windows)	(1) TS	(5) TS, I4, I2, I1, BS		N/A	
		Intermediate (Windows)	(2) TS, IW	(5) TS, IW, I2, I1, BS		N/A	

Strutting Schedule For Model 8500 Aluminum (White, Almond and Taupe Colored Doors)								
Door Heights	Section Qty	Section Type	Door Widths					
			6' 1" - 9' 0"	10' 0"	12' 0" - 14' 0"	15' 0" - 16' 0"	17' 0" - 18' 0"	20' 0"
<= 8' 0"	4 Or 5	Solid	(1) TS	(2) TS, LS	(3) TS, LS, BS	(4) 3" No strut on lock for 5 section 8' high	(1) TS	
		Top (Windows)	(1) TS	(2) 2" TS, LS	(3) TS, LS, BS	(1) 3" TS, (2) 2" LS, BS	(4) 3" No strut on lock for 5 section 8' high	(1) TS
		Intermediate (Windows)	(1) TS	(2) 2" TS, IW	(3) TS, IW, BS	(4) 3" No strut on lock for 5 section 8' high		(1) TS
> 8' 0"	5 Or 6	Solid	(1) TS	(2) 2" TS, LS	(4) TS, I1, LS, BS	(4 or 5) 2" Sections minus 1	N/A	
		Top (Windows)	(1) TS	(2) TS, LS	(4) TS, I1, LS, BS	(1) 3" Top, (3 or 4) 2" Sections minus 1	N/A	
		Intermediate (Windows)	(1) TS	(2) TS, IW	(4) TS, IW, I1, BS	(4 or 5) 2" Sections minus 1	N/A	

Strutting Schedule For Model 8500 Aluminum (Brown, Black and Woodgrain Colored Doors)						
Door Heights	Section Qty	Section Type	Door Widths			
			6' 1" - 10' 0"	12' 0" - 16' 0"	17' 0" - 18' 0"	20' 0"
<= 8' 0"	4 Or 5	Solid / Top (Windows)	(1) TS	(3) TS, LS, BS		ES
> 8' 0"	5 Or 6	Intermediate (Windows)	(1) TS	(4) TS, I1, LS, BS	(4) TS, I3, I1, BS	N/A

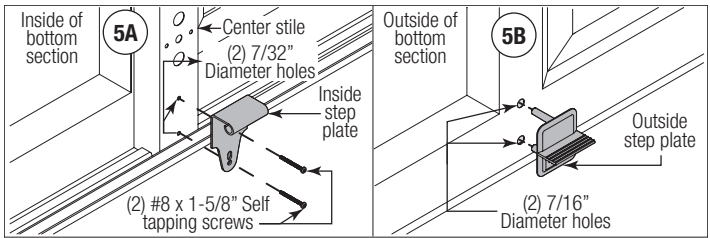

FOR MODELS 8300 / 8500:

CAUTION
DO NOT DRILL THROUGH OR ENLARGE HOLES ON THE INSIDE OF THE DOOR SECTION.

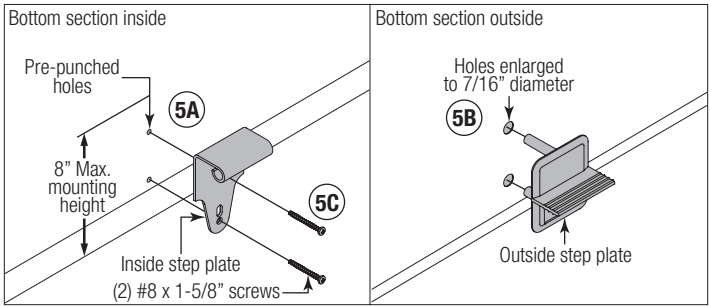

6 Lift Handle
Tools Required: Power drill, 9/32" x 1/2" Drill bits, 1/4" Wrench, Tape measure, Safety glasses, Leather gloves

FOR MODELS 8000 / 8100 / 8200:

IMPORTANT: THE DISTANCE BETWEEN THE STEP PLATE AND THE MIDDLE OF THE LIFT HANDLE MUST BE 20" MINIMUM TO 30" MAXIMUM. IF NECESSARY REPOSITION THE UPPER LIFT HANDLE TO STAY WITHIN THE REQUIRED DIMENSION.

NOTE: Do not drill through or enlarge holes on the inside of the door.

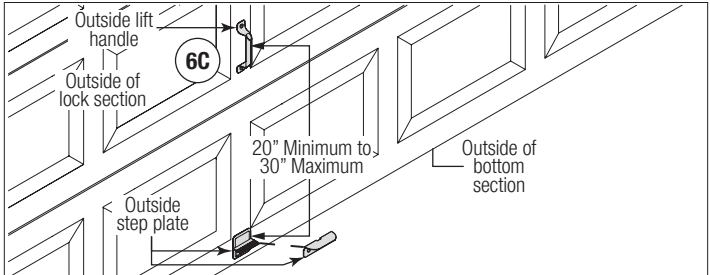
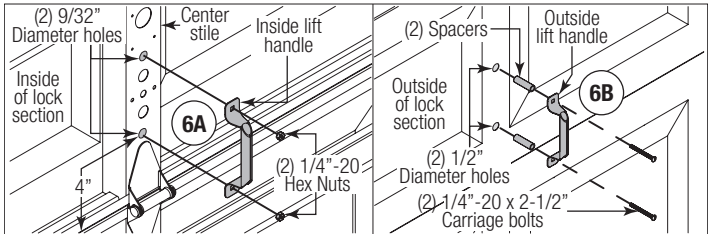

FOR MODELS 8300 / 8500:

CAUTION
DO NOT DRILL THROUGH OR ENLARGE HOLES ON THE INSIDE OF THE DOOR SECTION.

5 Attaching Step Plate To Bottom Section
Tools Required: Power drill, 7/16" Socket driver, Tape measure, Level, Step ladder, Safety glasses, Leather gloves

FOR MODELS 8000 / 8100 / 8200:

IMPORTANT: BE EXTREMELY CAREFUL TO KEEP DRILL STRAIGHT.
IMPORTANT: DO NOT MOUNT THE STEP PLATE HIGHER THAN 6" FROM THE BOTTOM OF THE SECTION.

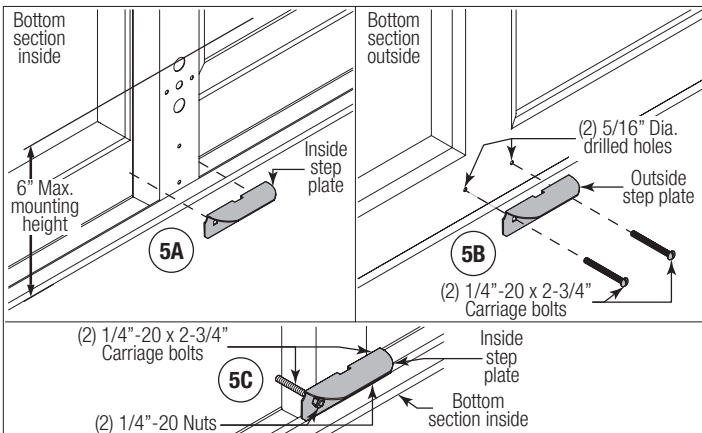

NOTE: Do not drill through or enlarge holes on the inside of the door.

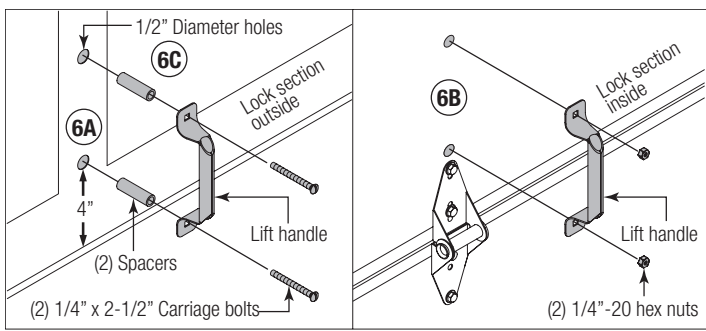

9 Attaching Top Fixtures To Top Section

Tools Required: Power drill, 7/16\"/>

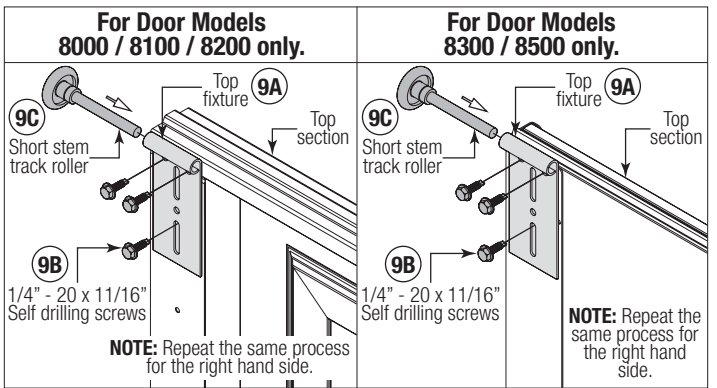

7 Positioning Bottom Section

Tools Required: Tape measure, Level, Wooden shims (if necessary), Safety glasses, Leather gloves

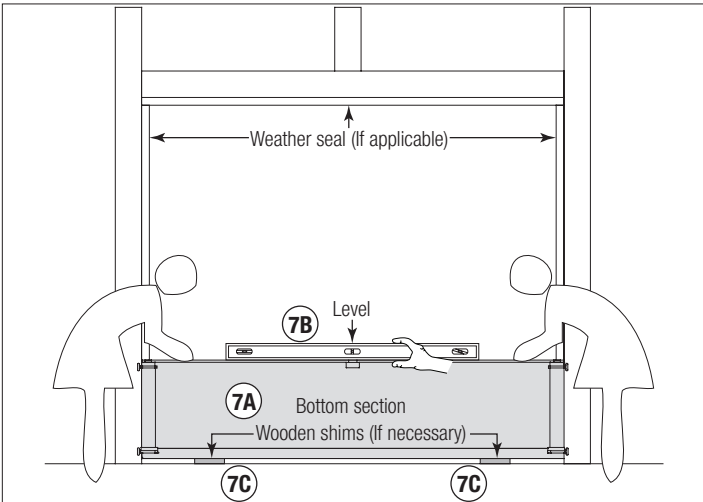

10 Stacking Sections

Tools Required: Power drill, 7/16\"/>

NOTE: Make sure graduated end and center hinges are flipped down, when stacking another section on top.

IMPORTANT: PUSH & HOLD THE HINGE LEAFS SECURELY AGAINST THE SECTIONS WHILE SECURING WITH FASTENERS TO IT. THERE SHOULD BE NO GAP BETWEEN THE HINGE LEAVES AND THE SECTIONS.

8 Attaching Vertical Tracks To Jamb

Tools Required: Power drill, 3/16\"/>

IMPORTANT: IF YOUR DOOR IS TO BE INSTALLED PRIOR TO A FINISHING CONSTRUCTION OF THE BUILDING'S FLOOR, THE VERTICAL TRACKS AND THE DOOR BOTTOM SECTION ASSEMBLY SHOULD BE INSTALLED SUCH THAT WHEN THE FLOOR IS CONSTRUCTED, NO DOOR OR TRACK PARTS ARE TRAPPED IN THE FLOOR CONSTRUCTION.

IMPORTANT: THE TOPS OF THE VERTICAL TRACKS MUST BE LEVEL FROM SIDE TO SIDE. IF THE BOTTOM SECTION WAS SHIMMED TO LEVEL IT, THE VERTICAL TRACK ON THE SHIMMED SIDE MUST BE RAISED THE HEIGHT OF THE SHIM.

NOTE: Make sure the counterbalance lift cable is located between the track rollers and the door jamb.

Position the left hand vertical track assembly over the track rollers of the bottom section and install, as shown. Drill 3/16\"/>

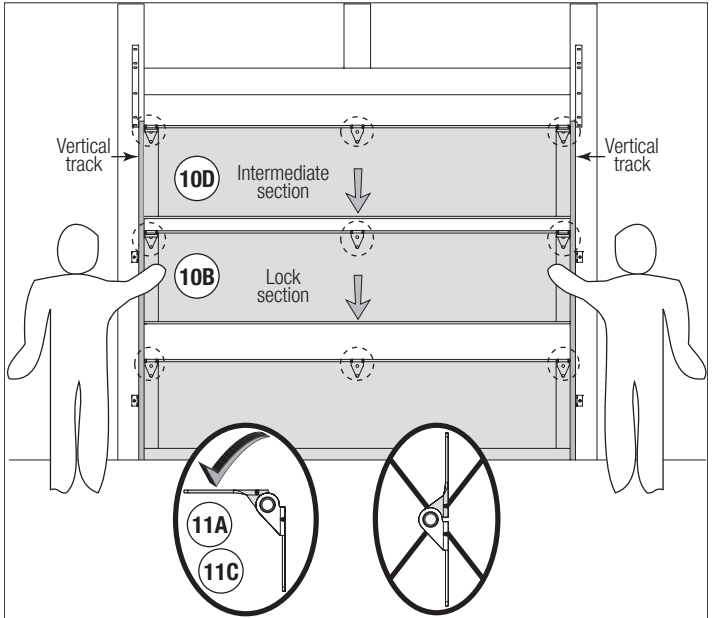
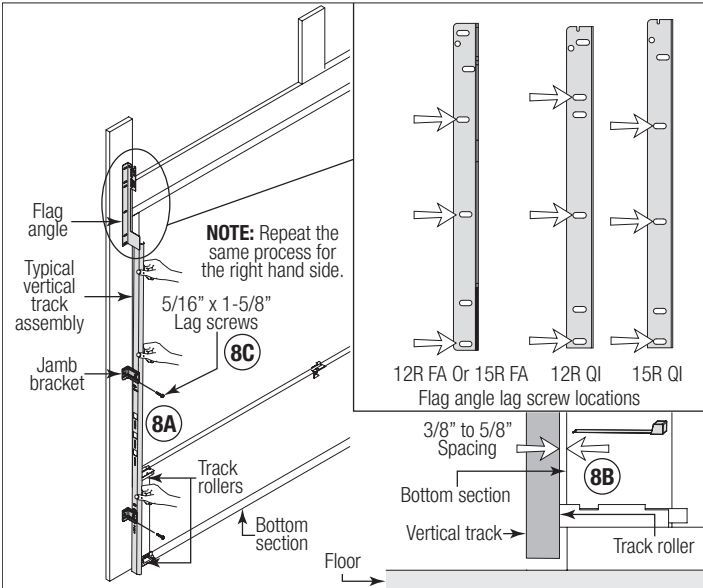

FOR MODELS 8000 / 8100 / 8200:

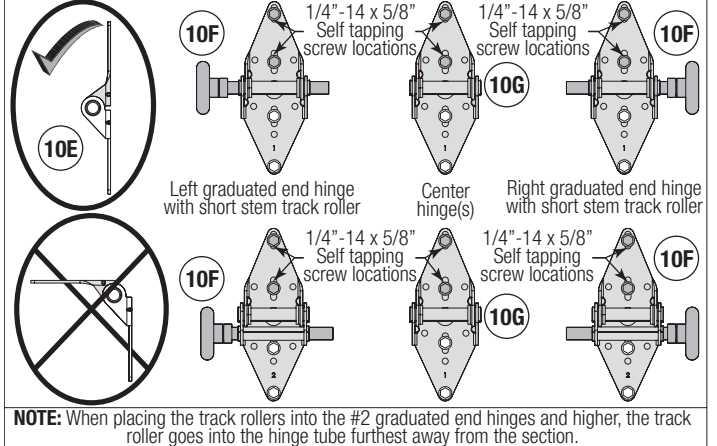

FOR MODELS 8300 / 8500:

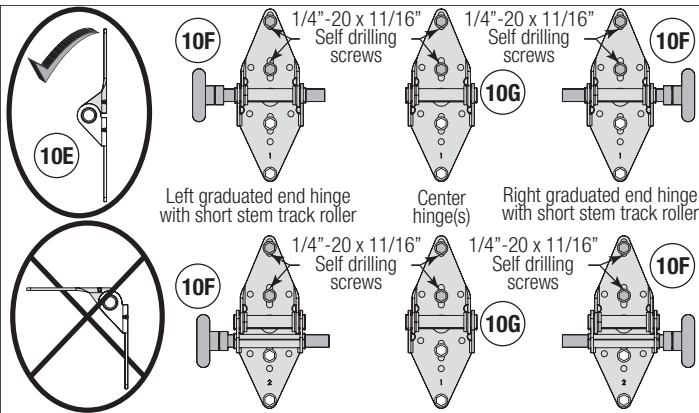

NOTE: When placing the track rollers into the #2 graduated end hinges and higher, the track roller goes into the hinge tube furthest away from the section.

11

Stacking Top Section

Tools Required: Power drill, 7/16" Socket driver, 7/16" Wrench, Step ladder, Tape measure, Safety glasses, Leather gloves

IMPORTANT: THE DIMENSION BETWEEN THE FLAG ANGLES OR WALL ANGLES MUST BE DOOR WIDTH PLUS 3-3/8" (86MM) TO 3-1/2" (89 MM) FOR SMOOTH, SAFE DOOR OPERATION.

Install a nail to prevent the top section from falling backwards.

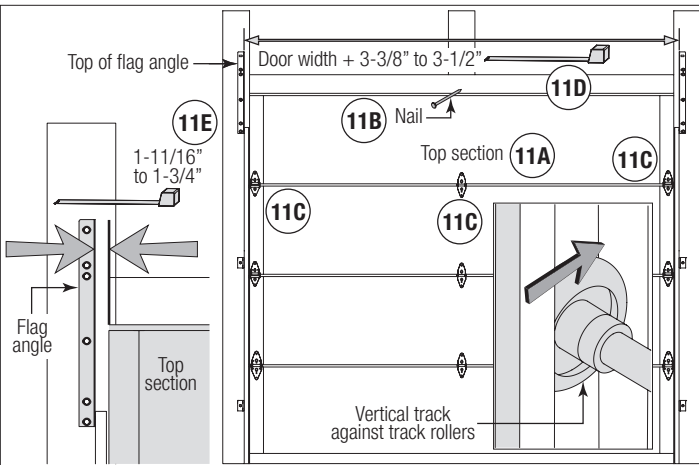

12

Attaching Horizontal Tracks

Tools Required: Ratchet wrench, 7/16" Socket, 7/16" Wrench, Step ladder, Tape measure, Safety glasses, Leather gloves

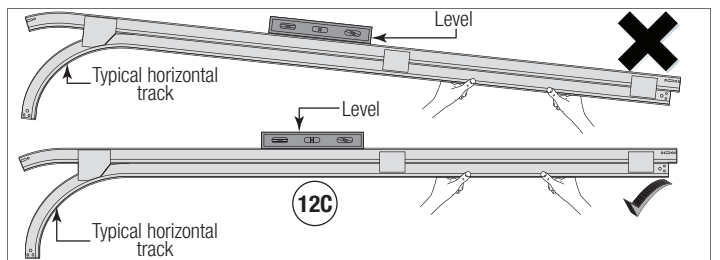
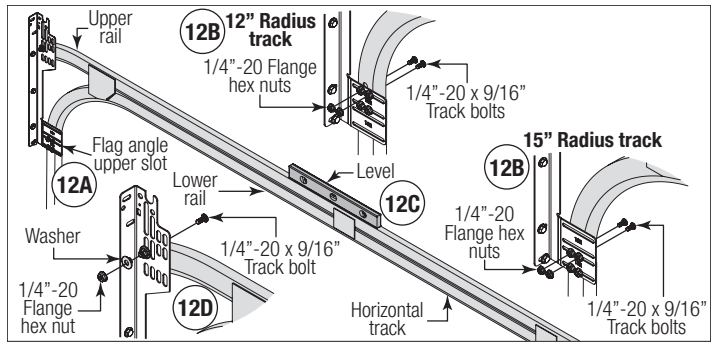
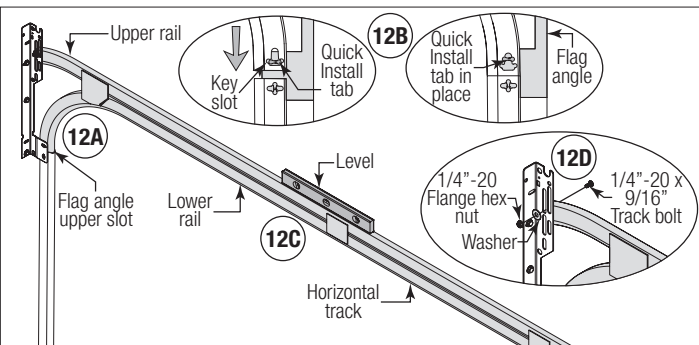

WARNING

DO NOT RAISE DOOR UNTIL HORIZONTAL TRACKS ARE SECURED AT REAR, AS OUTLINED IN STEP A9, OR DOOR COULD FALL FROM OVERHEAD POSITION CAUSING SEVERE OR FATAL INJURY.

Remove nail that was temporarily holding the top section in position.

IMPORTANT: FAILURE TO REMOVE NAIL BEFORE ATTEMPTING TO RAISE DOOR COULD CAUSE PERMANENT DAMAGE TO TOP SECTION.

13

Adjusting Top Fixtures

Tools Required: 7/16" / 9/16" Wrench, Step ladder, Tape measure, Safety glasses, Leather gloves

NOTE: Repeat the same process for the other side.

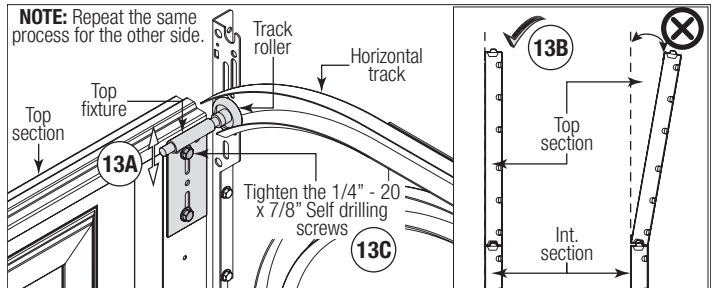

NOTE: Repeat the same process for the other side.

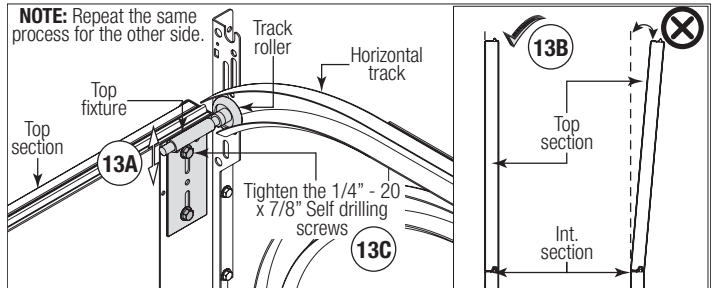

14

Attaching Inside Lock

Tools Required: Power drill, 9/32" Drill bits, Tape measure, Safety glasses, Leather gloves

IMPORTANT: INSIDE LOCK(S) MUST BE REMOVED OR MADE INOPERATIVE IN THE UNLOCKED POSITION BEFORE INSTALLING THE COUNTERBALANCE AND IF AN OPERATOR IS INSTALLED ON THIS DOOR.

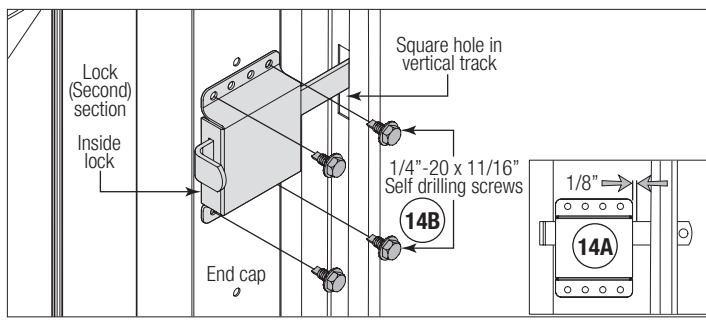

COUNTERBALANCE INSTALLATION INSTRUCTIONS

- NOTE:** Refer to parts breakdown, to determine what type of counterbalance you have.
- NOTE:** If your door has TorqueMaster® Front Mount LHR, proceed to Step A1.
- NOTE:** If your door has TorqueMaster® Rear Mount LHR, proceed to Step B1.
- NOTE:** If your door has Torsion Front Mount LHR Inside Hookup, proceed to Step C1.
- NOTE:** If your door has Torsion Front Mount LHR Outside Hookup, proceed to Step D1.
- NOTE:** If your door has Torsion Rear Mount LHR Outside Hookup, proceed to Step E1.
- NOTE:** If your door has Extension LHR, proceed to Step F1.

TORQUEMASTER® FRONT MOUNT LHR

NOTE: Some graphics in "A" are designated as either single spring applications or double spring applications.



A1 Preparing The TorqueMaster® Spring Tube Assembly

Tools Required: Safety glasses, Leather gloves

NOTE: TorqueMaster® springs come lubricated and pre-assembled inside the TorqueMaster® spring tube.

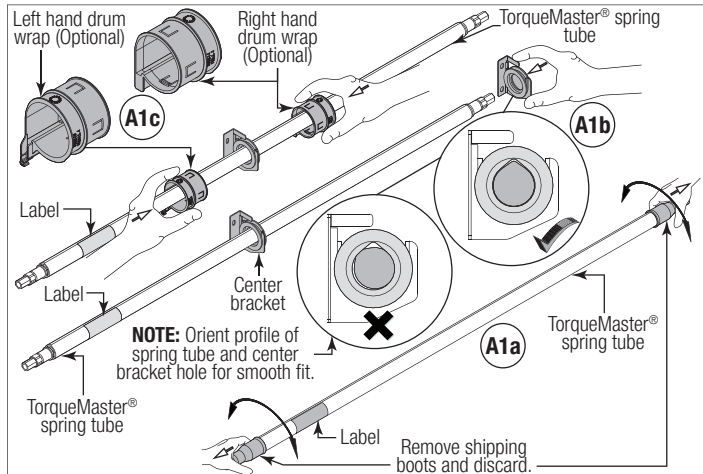

A2 Installing Cable Drum Assemblies

Tools Required: Tape measure, Step ladder, Safety glasses, Leather gloves

NOTE: Cable drum assemblies are marked right and left hand. Cable drums and TorqueMaster® spring tube assembly are cam shaped to fit together only one way.

NOTE: Temporarily support the center of the TorqueMaster® spring tube assembly until the center bracket is installed in step A4.

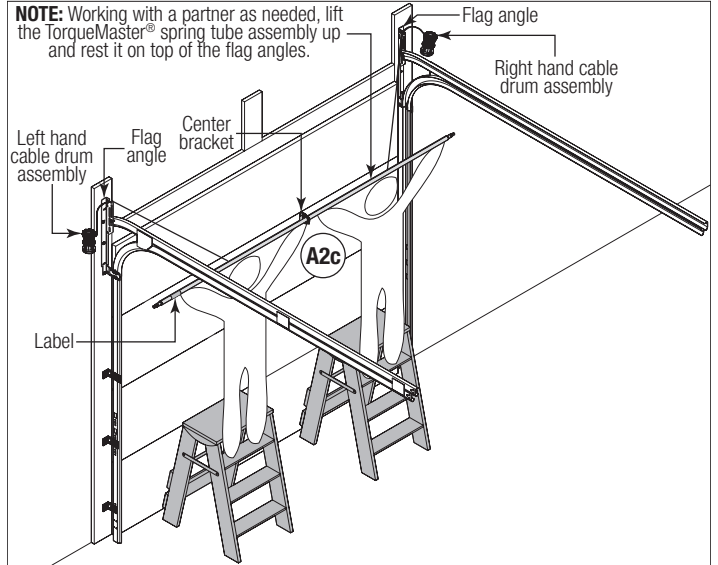
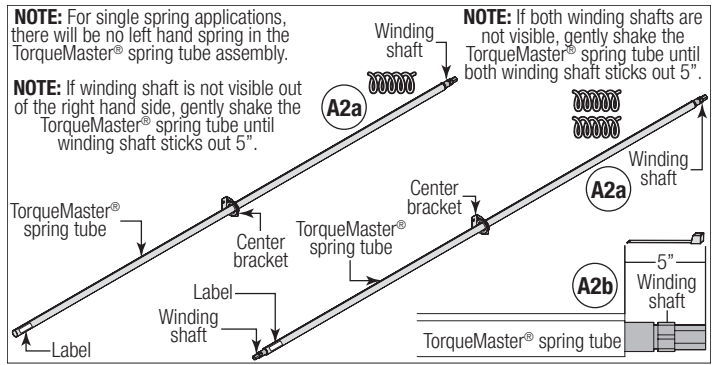

FOR SINGLE SPRING APPLICATIONS:

IMPORTANT: ENSURE THE SNAPS ON THE IDLER BRACKET (LEFT HAND SIDE) ARE ENGAGED INTO THE LEFT HAND CABLE DRUM, SO THAT IT DOES NOT COME BACK OUT.

NOTE: The idler bracket is designed for permanent assembly. Do not attempt to remove idler bracket once inserted into the cable drum.

NOTE: The idler bracket must extend past the cable drum far enough to expose the groove.

Align the idler bracket groove with the round notch in the flag angle.

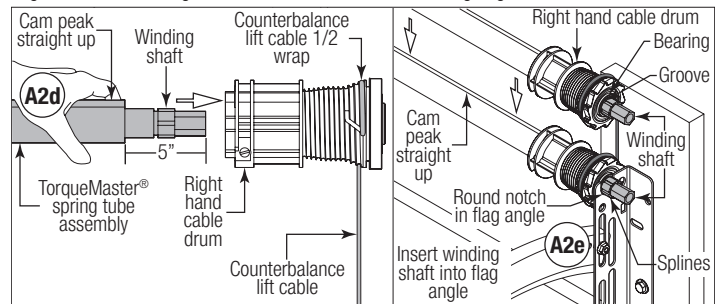

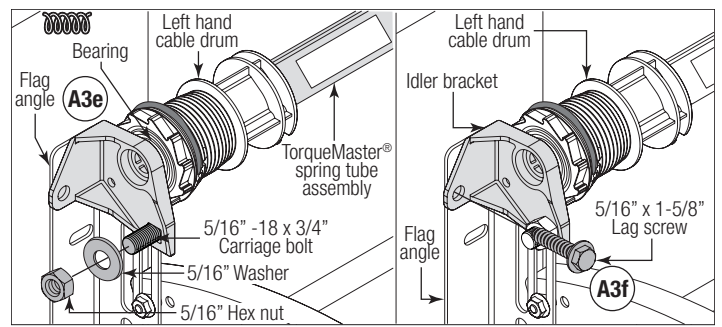
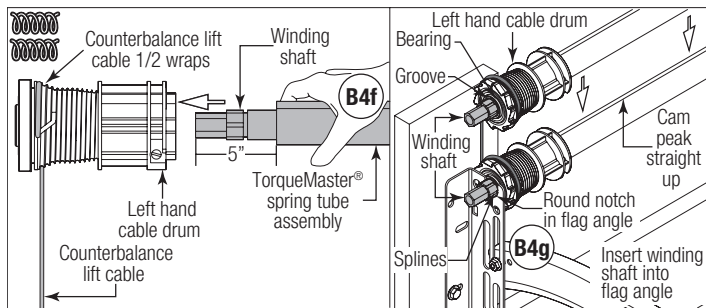
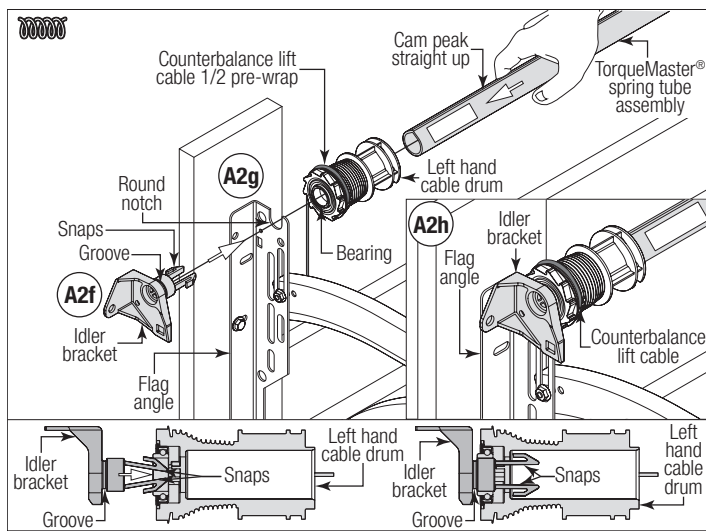

A4

Attaching Center Bracket to Wall

Tools Required: Power drill, 3/16" Drill bit, 7/16" Socket driver, Level, Tape measure, Step ladder, Safety glasses, Leather gloves

IMPORTANT: TORQUEMASTER® SPRING TUBE MUST BE LEVEL BEFORE SECURING CENTER BRACKET BUSHING ASSEMBLY TO HEADER.

NOTE: Drill 3/16" pilot holes into header for the lag screws.

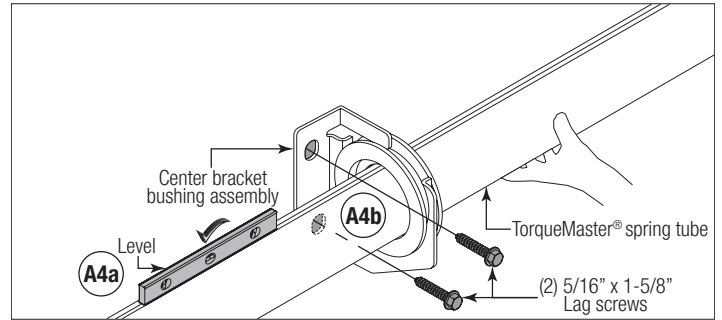

A5

Securing Door For Winding Spring(s)

Tools Required: Locking pliers, Step ladder, Safety glasses, Leather gloves

WARNING

FAILURE TO PLACE LOCKING PLIERS ONTO VERTICAL TRACK CAN ALLOW DOOR TO RAISE AND CAUSE SEVERE OR FATAL INJURY.

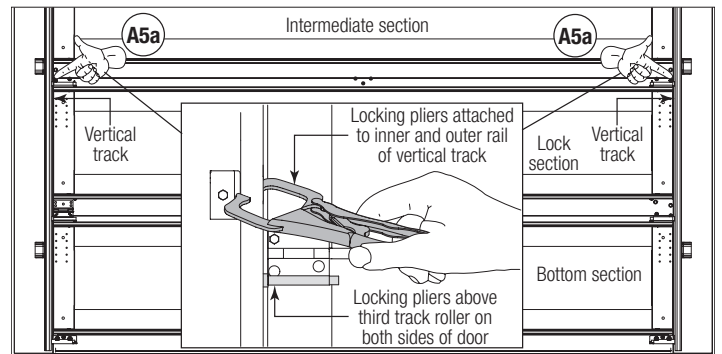

A6

Adjusting Counterbalance Lift Cable

Tools Required: Locking pliers, Flat tip screwdriver, Step ladder, Tape measure, Pliers / Wire cutters, Safety glasses, Leather gloves

IMPORTANT: ENSURE THE COUNTERBALANCE LIFT CABLE IS SEATED IN THE FIRST GROOVE OF THE CABLE DRUM PRIOR TO WINDING SPRINGS.

A3

Attaching End Brackets To Flag Angles

Tools Required: Power drill, 3/16" Drill bit, 7/16" Socket driver, 1/2" Wrench, Tape measure, Step ladder, Safety glasses, Leather gloves

IMPORTANT: WARNING TAGS MUST BE SECURELY ATTACHED TO END BRACKET(S).

IMPORTANT: FOR SINGLE SPRING DOORS, ENSURE THE LEFT HAND CABLE DRUM BEARING IS ALL THE WAY TO THE LEFT AND UP AGAINST THE FLAG ANGLE. IF THE CABLE DRUM IS PULLED AWAY FROM THE FLAG ANGLE, THEN THE IDLER BRACKET CAN RUB AGAINST THE CABLE DRUM CAUSING NOISE.

NOTE: Drill 3/16" pilot holes into header for the lag screws.

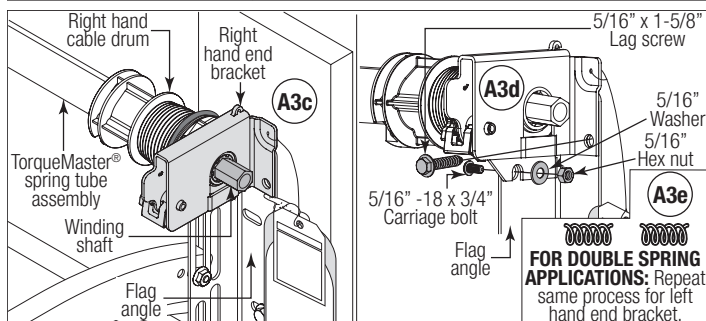
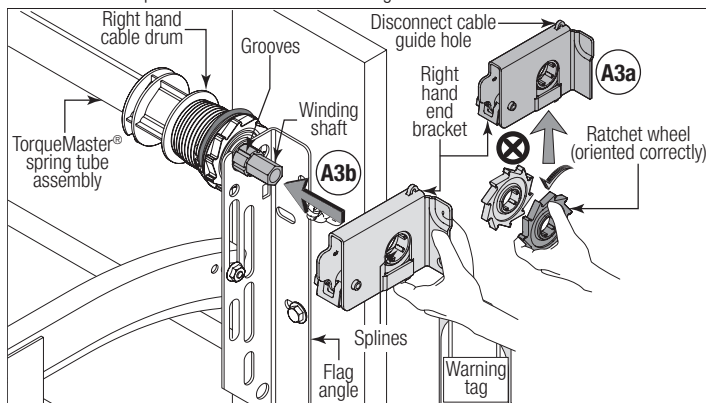

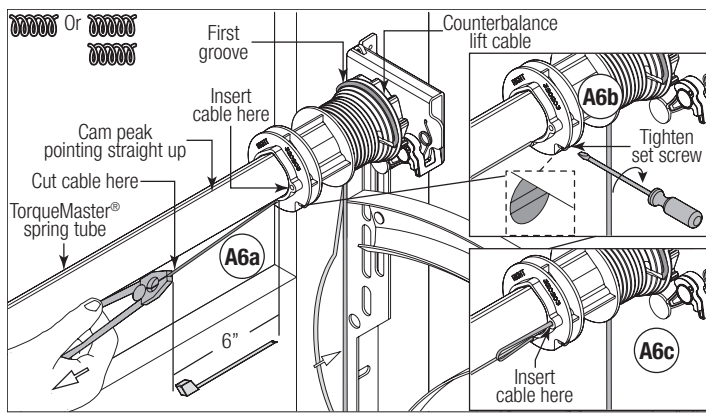

NOTE: Illustration shows the right hand cable drum assembly. Repeat the same process for the left hand side.

A7

Winding Spring(s)

Tools Required: Ratchet wrench, 5/8" Socket, 3" Ratchet extension, Step ladder, Tape measure, Safety glasses, Leather gloves

IMPORTANT: VERIFY THAT THERE ARE NO OBSTRUCTIONS IN THE TRAVEL PATH OF THE DOOR SECTIONS OR COUNTERBALANCE LIFT CABLES.

IMPORTANT: INSPECT EACH COUNTERBALANCE LIFT CABLE MAKING SURE IT IS SEATED PROPERLY ONTO THE CABLE DRUM AND THAT BOTH COUNTERBALANCE LIFT CABLES HAVE EQUAL TENSION.

PRIOR TO WINDING SPRING(S), CHECK COUNTERBALANCE LIFT CABLES FOR EQUAL TENSION:

1. Attach locking pliers to track above top roller.
2. Grasp cable at approximate mid-door height location.
3. Draw cable toward you about 1/2" to 1" and release, noting the response of the cable.
4. Repeat above steps for other cable.
5. Adjust cable tension as needed until right and left cables both respond the same.

⚠ WARNING

WINDING SPRING IS AN EXTREMELY DANGEROUS PROCEDURE AND SHOULD BE PERFORMED ONLY BY A TRAINED DOOR SYSTEM TECHNICIAN USING PROPER TOOLS AND INSTRUCTIONS.

⚠ WARNING

IT IS RECOMMENDED THAT LEATHER GLOVES BE WORN WHILE WINDING SPRINGS. FAILURE TO WEAR GLOVES MAY CAUSE INJURY TO HANDS.

NOTE: A 3" ratchet extension is recommended for added clearance from the horizontal track angle.

IMPORTANT: PAWL KNOB MUST BE IN UPPER POSITION TO ADD / REMOVE REQUIRED NUMBER OF SPRING TURNS.

There are two methods for counting the spring turns as you wind. One method is to identify the black tooth on the ratchet wheel inside of the end bracket. When the wheel makes one revolution and the tooth returns to its starting point, one turn has been made. The other method is to make a mark on the winding shaft (or socket) and end bracket, and count your turns in this manner.

Check the label attached to the spring warning tag or the Winding Spring Turn Chart (below) for the required number of complete turns to balance your door.

IMPORTANT: MARK THE NUMBER OF SPRING TURNS ONTO THE END BRACKET WARNING TAG.

WINDING SPRING TURN CHART

DOOR HEIGHT	SPRING TURNS
6'-0"	14
6'-3"	14-1/2
6'-5" - 6'-6"	15
6'-8" - 6'-9"	15-1/2
7'-0"	16
7'-3"	16-1/2
7'-6"	17
7'-9"	17-1/2
8'-0"	18

NOTE: Since total turns to balance door can deviate from winding spring turn chart values by ± 1 turn, adjustments to the recommended number of turns may be required after rear back hangs are installed.

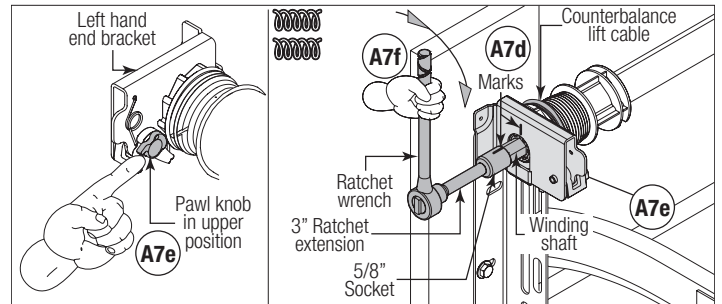
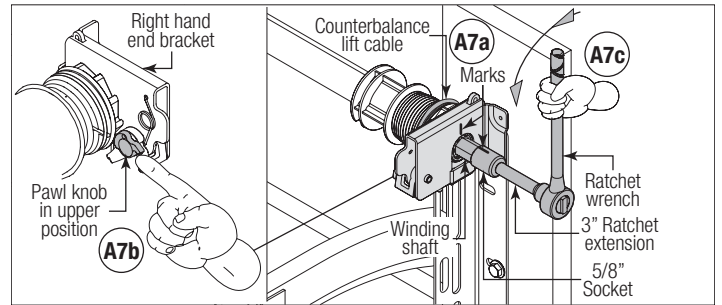

A8

Securing Drum Wraps (Optional)

Tools Required: Step ladder, Safety glasses, Leather gloves

NOTE: If you don't have drum wraps, then skip this step. Refer to Package Contents / Parts Breakdown, to determine if you have drum wraps.

IMPORTANT: PULL THE COUNTERBALANCE LIFT CABLE AWAY FROM THE HEADER TO CLEAR THE LATCH, WHILE SIMULTANEOUSLY SLIDING THE DRUM WRAP AGAINST THE LAST RIB UNTIL THE THREE CATCHES ENGAGE THE 3RD RIB.

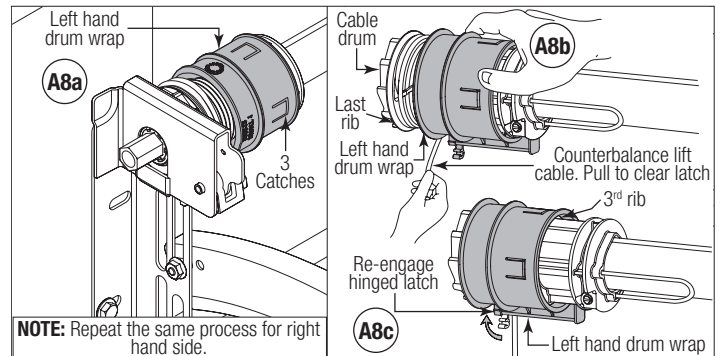

NOTE: Repeat the same process for right hand side.

A9

Attaching Rear Back Hangs

Tools Required: Ratchet wrench, Socket: 1/2", Wrench: 1/2", 3" Ratchet extension, (2) Locking pliers, Step ladder, Tape measure, Safety glasses, Leather gloves

IMPORTANT: HOLD THE DOOR DOWN TO PREVENT IT FROM RISING UNEXPECTEDLY IN THE EVENT THE SPRING(S) WERE OVER-WOUND AND CAUTIOUSLY REMOVE LOCKING PLIERS FROM VERTICAL TRACKS.

Raise the door until the top section and half of the next section are in the horizontal track radius. Do not raise door any further since rear of horizontal tracks are not yet supported.

⚠ WARNING

RAISING DOOR INTO THE LOOSE HORIZONTAL TRACKS CAN RESULT IN DOOR FALLING AND CAUSE SEVERE OR FATAL INJURY.

Clamp a pair of locking pliers onto the vertical tracks just above the second track roller on one side, and just below the second track roller on the other side. This will prevent the door from raising or lowering while installing the rear back hangs.

Using the chart below, select the appropriate perforated angle (may not be supplied). Fabricate and install rear back hangs, as shown.

Perforated Angle Gauge Weight Limitations:

Perforated Angle Gauge	Door Balance Weight
2" x 2" x 12 Gauge	800 lbs. to 1600 lbs.
1-1/4" x 1-1/4" x 13 Gauge	305 lbs. to 610 lbs.

Perforated Angle Gauge Weight Limitations:

Perforated Angle Gauge	Door Balance Weight
1-1/4" x 1-1/4" x 15 Gauge	220 lbs. to 440 lbs.
1-1/4" x 1-1/4" x 16 Gauge	175 lbs. to 350 lbs.

NOTE: If an opener is installed, position horizontal tracks one hole above level when securing them to the rear back hangs.

WARNING

KEEP HORIZONTAL TRACKS PARALLEL AND WITHIN 3/4" TO 7/8" FROM DOOR EDGE, OTHERWISE DOOR COULD FALL, RESULTING IN SEVERE OR FATAL INJURY.

IMPORTANT: DO NOT SUPPORT THE WEIGHT OF THE DOOR ON ANY PART OF THE REAR BACK HANGS THAT CANTILEVERS 4" OR MORE BEYOND A SOUND FRAMING MEMBER.

NOTE: If rear back hangs are to be installed over drywall, use (2) 5/16" x 2" hex head lag screws and make sure lag screws engage into solid structural lumber.

WARNING

FAILURE TO ASSEMBLE AND ATTACH REAR BACK HANGS PROPERLY ACCORDING TO THE ABOVE INSTRUCTIONS MAY RESULT IN DOOR FALLING WHEN RAISED, CAUSING SEVERE OR FATAL INJURY.

NOTE: Perforated angle must be attached to sound framing members and **nails should not be used.**

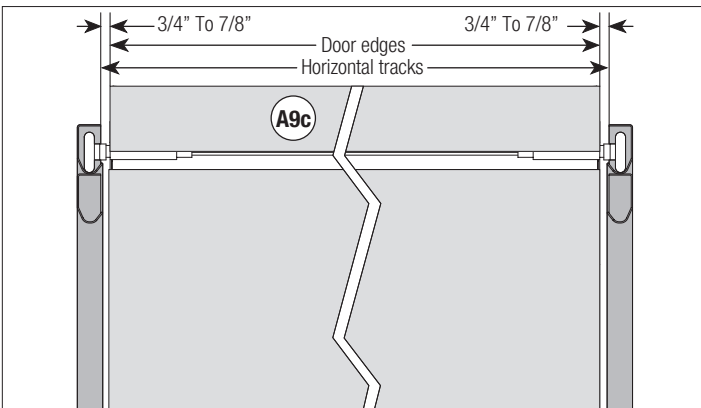
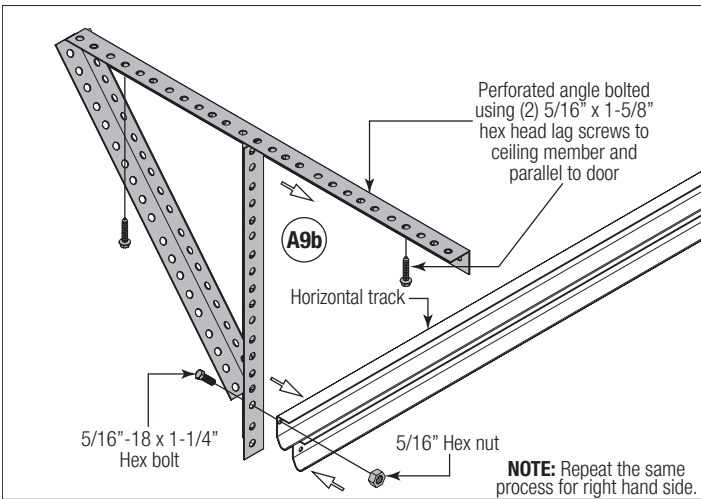
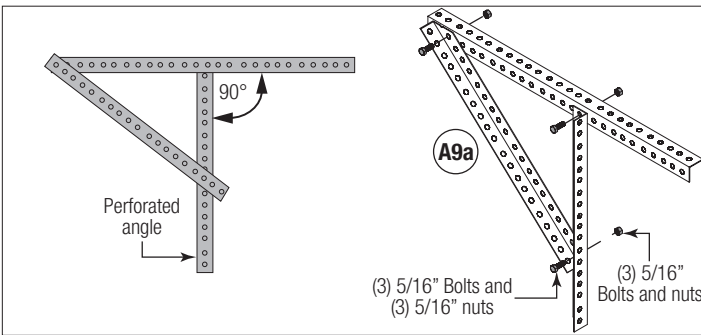

A10

Attaching Weather Seal

Tools Required: Hammer, Step ladder, Safety glasses, Leather gloves

Permanently attach the weatherstrips on both door jambs and header. The weatherstrips were temporarily attached in Preparing the Opening, in the pre-installation section of this manual.

NOTE: When permanently attaching the weatherstrips to the jambs, avoid pushing the weatherstrips too tightly against the face of door.

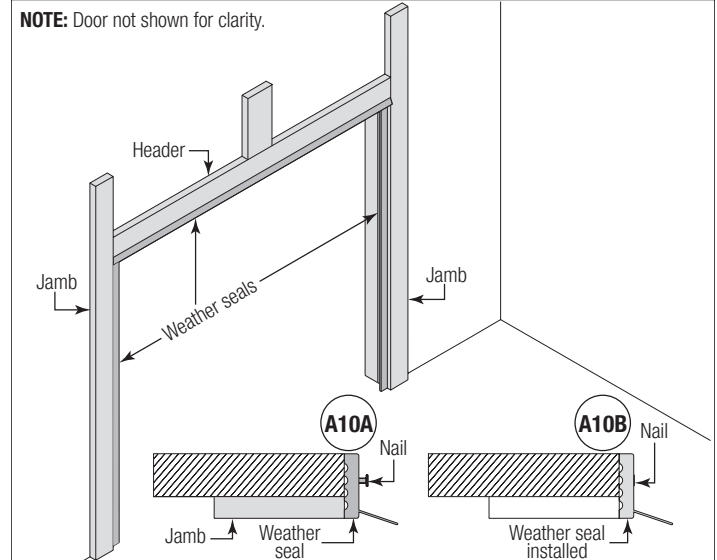

A11

Balancing Door

Tools Required: Ratchet wrench, Socket: 5/8", Wrench: 5/8", 3" Ratchet extension, (2) Locking pliers, Step ladder, Tape measure, Safety glasses, Leather gloves

NOTE: Windows may cause the top section to be significantly heavier than the remaining sections. Wayne Dalton attempts to balance the door at the top and bottom. To prevent any sudden door acceleration between the top and bottom, we recommend motor operating all doors with windows.

Remove any locking pliers. Lift the door and check its balance. Adjust spring(s) if door lifts by itself (hard to pull down) or if door is difficult to lift (drifts down). Anytime spring adjustments are made, ratchet pawl knob must be in the upper position. An unbalanced door can cause TorqueMaster® Plus operation problems.

Close the door and place locking pliers onto both vertical tracks just above the third track roller. This is to prevent the garage door from rising while adjusting the spring(s).

IMPORTANT: TO ADJUST SPRINGS, ONLY ADD OR REMOVE A MAXIMUM OF 3/10 OF A TURN (THREE TEETH ON THE RATCHET WHEEL) AT A TIME. BOTH SIDES NEED TO BE ADJUSTED EQUALLY ON DOUBLE SPRING DOORS.

WARNING

WINDING SPRINGS IS AN EXTREMELY DANGEROUS PROCEDURE AND SHOULD BE PERFORMED ONLY BY A TRAINED DOOR SYSTEM TECHNICIAN USING PROPER TOOLS AND INSTRUCTIONS.

ADD SPRING TENSION: The ratchet wheel is made of 10 teeth. To add spring tension, tighten counter clockwise on the right hand side and clockwise on the left hand side. Place pawl knob in upper position. Place the ratchet with 5/8" socket and 3" ratchet extension onto the winding shaft, to add 3/10 of a turn. Watch as three teeth of the ratchet wheel pass over the pawl, creating three "clicks". Place pawl knob in lower position. For double spring applications, repeat the same process for the other side.

REMOVE SPRING TENSION: To remove spring tension, place a regular 5/8" wrench onto the winding shaft. Place pawl knob in upper position.

IMPORTANT: BE PREPARED TO HOLD THE FULL TENSION OF THE SPRING.

Push down on the wrench to relieve pressure between the pawl and the ratchet wheel. Push in on the pawl to allow the three ratchet wheel teeth to pass by the pawl, as you carefully allow the wrench to be rotated upward by the spring tension, release the pawl to allow it to engage with the ratchet wheel. Place pawl knob in lower position. For double spring applications, repeat the same process for the other side.

IMPORTANT: DO NOT ADD OR REMOVE MORE THAN 1 SPRING TURN (1 SPRING TURN EQUALS 10 TEETH ON RATCHET WHEEL) FROM THE RECOMMENDED NUMBER OF TURNS SHOWN ON THE WINDING SPRING TURN CHART.

If the door still does not operate easily, lower the door into the closed position, unwind spring(s) completely, and recheck the following items:

- 1.) Is the door level?
- 2.) Are the TorqueMaster® spring tube and flag angles level and plumb?

- 3.) Does the distance between the flag angles equal door width plus 3-3/8" to 3-1/2"?
- 4.) Do the counterbalance lift cables have equal tension? Adjust if necessary.
- 5.) Rewind the spring(s).
- 6.) Make sure door is not rubbing on jambs.

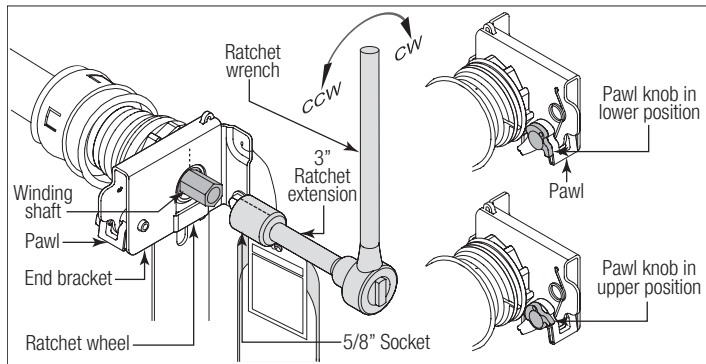

TORQUEMASTER® REAR MOUNT LHR

NOTE: Some graphics in "B" are designated as either single spring applications or double spring applications.



B1 Attaching Cable Lift Sheaves

Tools Required: Ratchet wrench, Socket: 9/16", Wrench: 9/16", (2) Locking pliers, Tape measure, Level, Step ladder, Safety glasses, Leather gloves

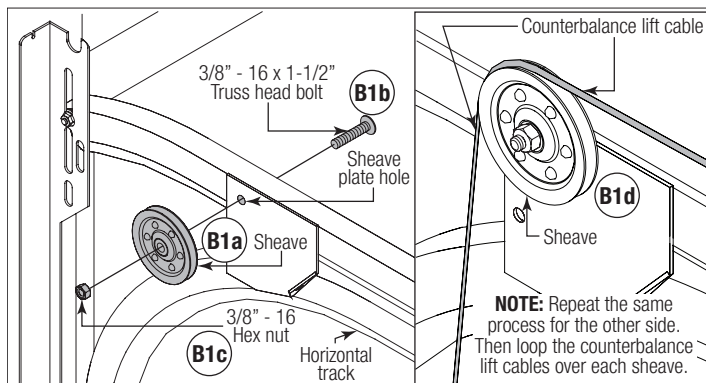

B2 Attaching Rear Back Hangs

Tools Required: Ratchet wrench, Socket: 1/2", Wrench: 1/2", (2) Locking pliers, Tape measure, Level, Step ladder, Safety glasses, Leather gloves

NOTE: Temporarily support the horizontal track with rear back hangs as shown in Step A9, without lifting door and then proceed to Step B3.

B3 Preparing The TorqueMaster® Spring Tube Assembly

Tools Required: Safety glasses, Leather gloves

NOTE: TorqueMaster® springs come lubricated and pre-assembled inside the spring tube. Parts are cam shaped to fit together only one way.

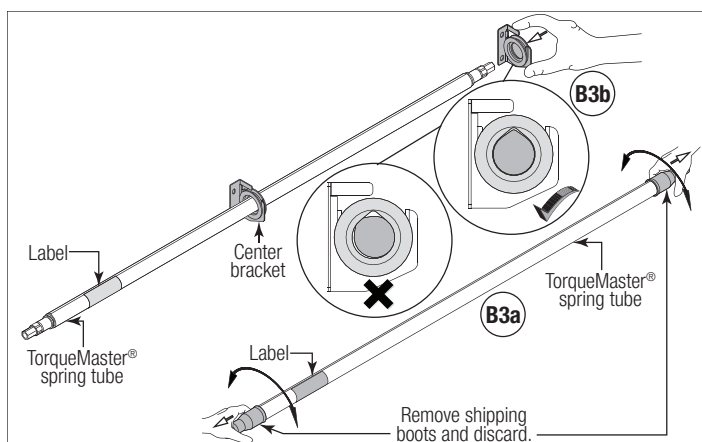

B4

Attaching Reinforcing Brackets (if included)

Tools Required: Ratchet wrench, 1/2" Socket, 1/2" Wrench, Step ladder, Safety glasses, Leather gloves

NOTE: If reinforcing brackets were not included, skip this step.

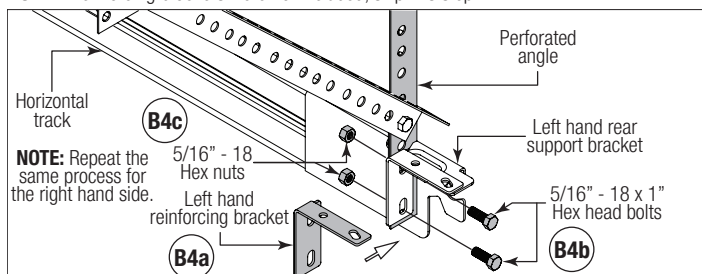

B5

Installing Cable Drum Assemblies

Tools Required: Tape measure, Step ladder, Safety glasses, Leather gloves

NOTE: Cable drum assemblies are marked right and left hand. Cable drums and TorqueMaster® spring tube assembly are cam shaped to fit together only one way.

NOTE: Temporarily support the center of the TorqueMaster® spring tube assembly until the center bracket is installed in step B7.

FOR SINGLE SPRING APPLICATIONS:

IMPORTANT: ENSURE THE SNAPS ON THE IDLER BRACKET (LEFT HAND SIDE) ARE ENGAGED INTO THE LEFT HAND CABLE DRUM, SO THAT IT DOES NOT COME BACK OUT.

NOTE: The idler bracket is designed for permanent assembly. Do not attempt to remove idler bracket once inserted into the cable drum.

NOTE: The idler bracket must extend past the cable drum far enough to expose the groove.

Align the idler bracket groove with the round notch in the flag angle.

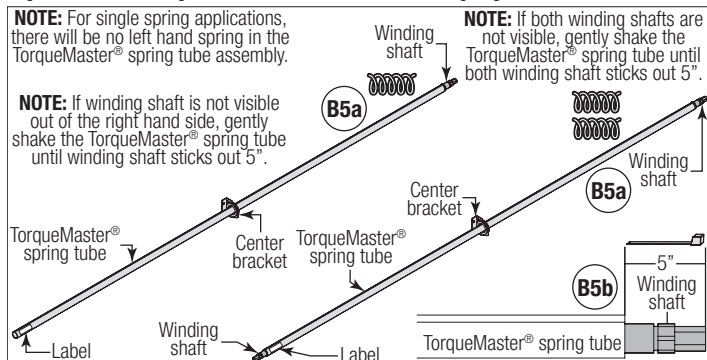

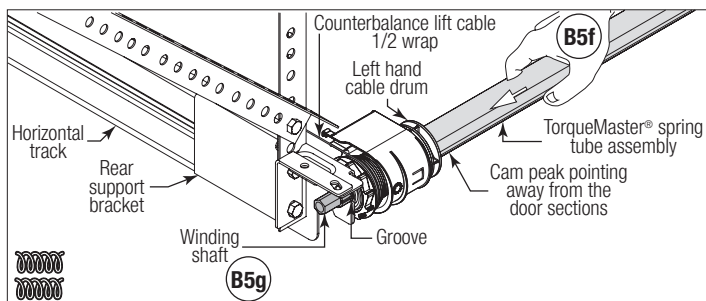
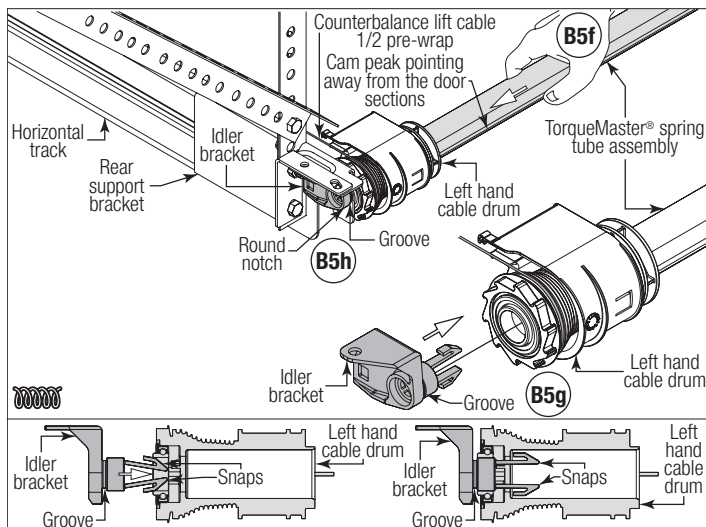
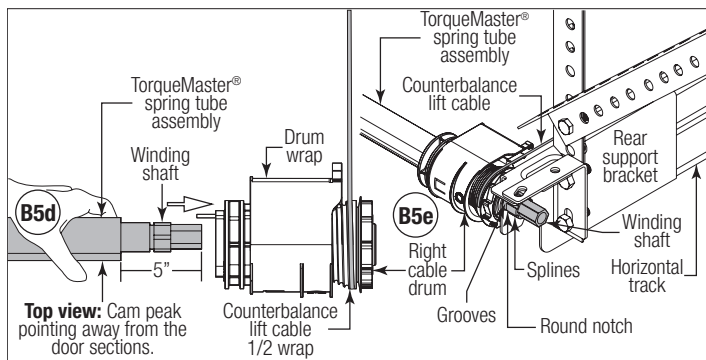
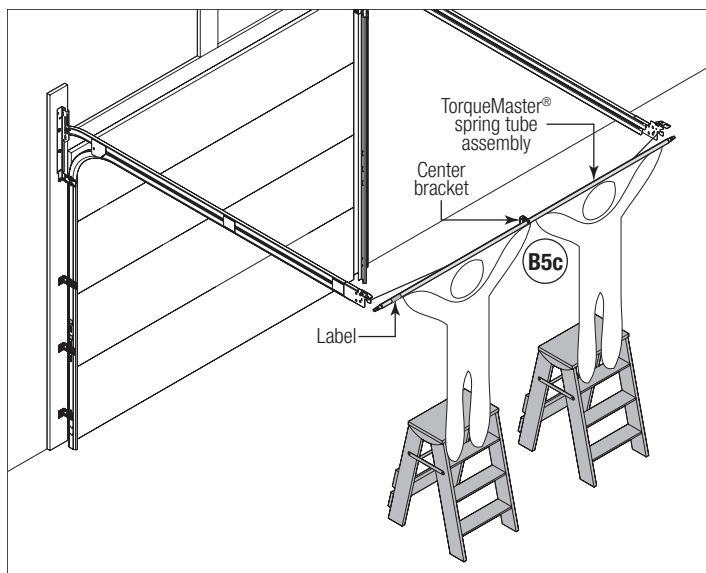

NOTE: On single spring applications, the idler was positioned in a previous step, but must be fastened in this step.

NOTE: On single spring applications, no ratchet wheel is required on the left hand side.

NOTE: If ratchet wheel falls out of end bracket, refer to illustration for proper insertion orientation.

NOTE: Ensure the 5/16" - 18 x 1" hex head bolt is going through the end bracket first and the 5/16" - 18 nut is on top of the rear support bracket or the reinforcing bracket (if included).

NOTE: Ensure the 1/4" - 20 x 9/16" track bolt is going through the inside of rear support bracket first, then the 5/16" flat washer and the 1/4" - 20 flange hex nut is on the outside of the rear support bracket.

NOTE: For single spring doors, make sure the cable drum is all the way up against the rear support bracket to avoid noise.

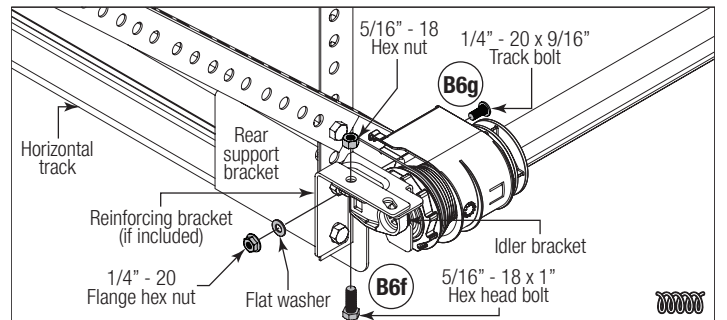
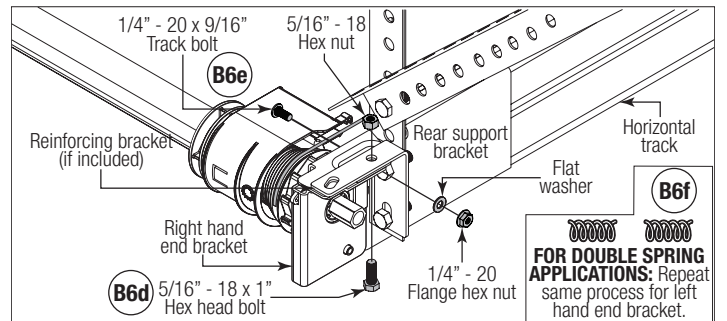
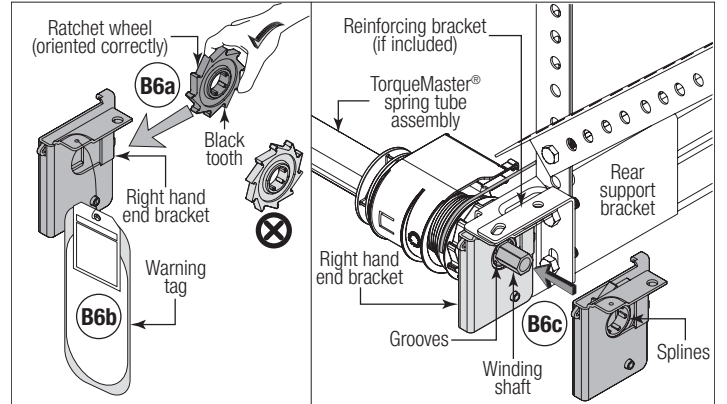

B7 Attaching Center Bracket

Tools Required: 1/2" Wrench, Level, Tape measure, Step ladder, Safety glasses, Leather gloves

IMPORTANT: TORQUEMASTER® SPRING TUBE MUST BE LEVEL BEFORE SECURING CENTER BRACKET BUSHING ASSEMBLY TO HEADER.

Referring to Step A9, locate the center of the TorqueMaster® spring tube and secure a perforated angle set to the ceiling as near to the center bracket bushing assembly location as possible. Slide the center bracket bushing assembly to the center of the TorqueMaster® spring tube. Position the center bracket assembly onto the perforated angle and secure using (2) 5/16" - 18 x 1" bolts and (2) 5/16" - 18 hex nuts (may not be supplied), keeping the TorqueMaster® spring tube level.

B6

Attaching End Brackets

Tools Required: Power drill, 7/16", 1/2" Socket, 7/16", 1/2" Wrench, Tape measure, Step ladder, Safety glasses, Leather gloves

IMPORTANT: WARNING TAGS MUST BE SECURELY ATTACHED TO END BRACKET(S).

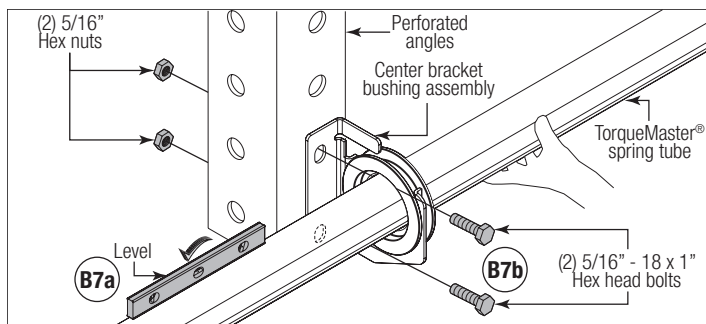

B8

Securing Door For Winding Spring(s)

Tools Required: Locking pliers, Step ladder, Safety glasses, Leather gloves

WARNING

FAILURE TO PLACE LOCKING PLIERS ONTO VERTICAL TRACK CAN ALLOW DOOR TO RAISE AND CAUSE SEVERE OR FATAL INJURY.

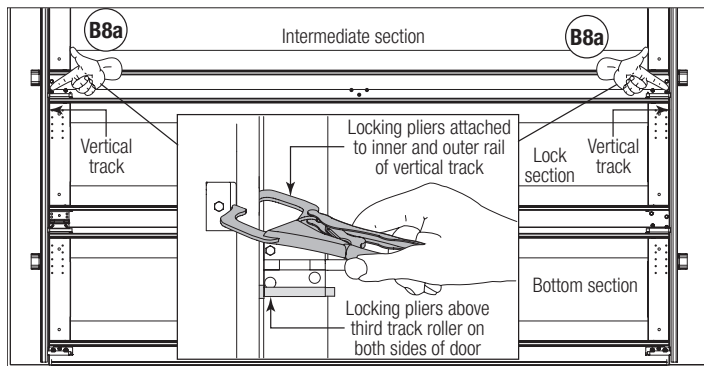

B9

Adjusting Counterbalance Lift Cable

Tools Required: Locking pliers, Flat tip screwdriver, Step ladder, Tape measure, Pliers / Wire cutters, Safety glasses, Leather gloves

IMPORTANT: ENSURE THE COUNTERBALANCE LIFT CABLE IS SEATED IN THE FIRST GROOVE OF THE CABLE DRUM PRIOR TO WINDING SPRINGS.

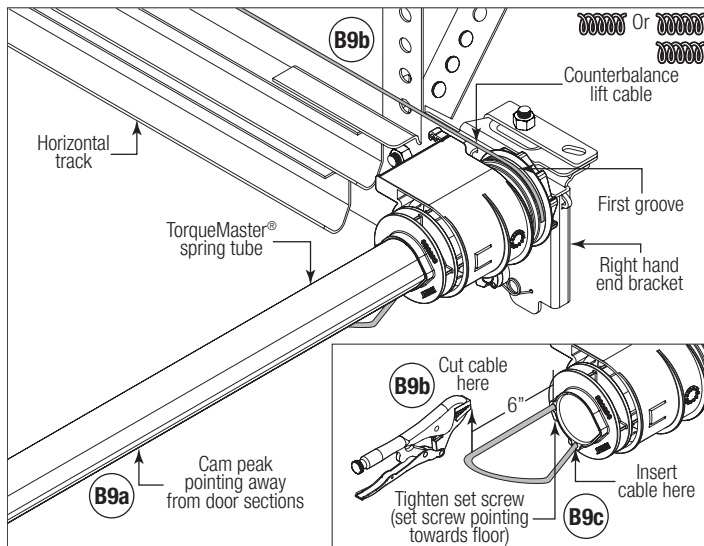

NOTE: Illustration shows the right hand cable drum assembly. Repeat the same process for the left hand side.

B10

Winding Spring(s)

Tools Required: Ratchet wrench, 5/8\"/>

IMPORTANT: VERIFY THAT THERE ARE NO OBSTRUCTIONS IN THE TRAVEL PATH OF THE DOOR SECTIONS OR COUNTERBALANCE LIFT CABLES.

IMPORTANT: INSPECT EACH COUNTERBALANCE LIFT CABLE MAKING SURE IT IS SEATED PROPERLY ONTO THE CABLE DRUM AND THAT BOTH COUNTERBALANCE LIFT CABLES HAVE

EQUAL TENSION.

PRIOR TO WINDING SPRING(S), CHECK COUNTERBALANCE LIFT CABLES FOR EQUAL TENSION:

1. Attach locking pliers to track above top roller.
2. Grasp cable at approximate mid-door height location.
3. Draw cable toward you about 1/2\"/>

WARNING

WINDING SPRING(S) IS AN EXTREMELY DANGEROUS PROCEDURE AND SHOULD BE PERFORMED ONLY BY A TRAINED DOOR SYSTEM TECHNICIAN USING PROPER TOOLS AND INSTRUCTIONS.

WARNING

IT IS RECOMMENDED THAT LEATHER GLOVES BE WORN WHILE WINDING SPRINGS. FAILURE TO WEAR GLOVES MAY CAUSE INJURY TO HANDS.

NOTE: A 3\"/>

IMPORTANT: PAWL KNOB MUST BE IN UPPER POSITION TO ADD / REMOVE REQUIRED NUMBER OF SPRING TURNS, AS SHOWN.

There are two methods for counting the spring turns as you wind. One method is to identify the black tooth on the ratchet wheel inside of the end bracket. When the wheel makes one revolution and the tooth returns to its starting point, one turn has been made. The other method is to make a mark on the winding shaft (or socket) and end bracket, and count your turns in this manner.

Check the label attached to the spring warning tag or the Winding Spring Turn Chart (below) for the required number of complete turns to balance your door.

IMPORTANT: MARK THE NUMBER OF SPRING TURNS ONTO THE END BRACKET WARNING TAG.

WINDING SPRING TURN CHART	
DOOR HEIGHT	SPRING TURNS
6'-0"	14
6'-3"	14-1/2
6'-5" - 6'-6"	15
6'-8" - 6'-9"	15-1/2
7'-0"	16
7'-3"	16-1/2
7'-6"	17
7'-9"	17-1/2
8'-0"	18

NOTE: Since total turns to balance door can deviate from chart values by ± 1 turn, adjustments to the recommended number of turns may be required after rear back hangs are installed.

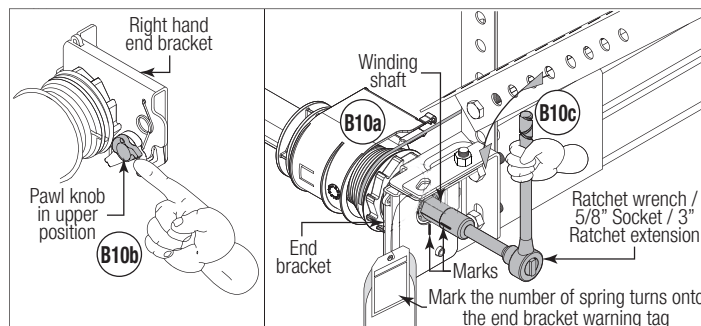

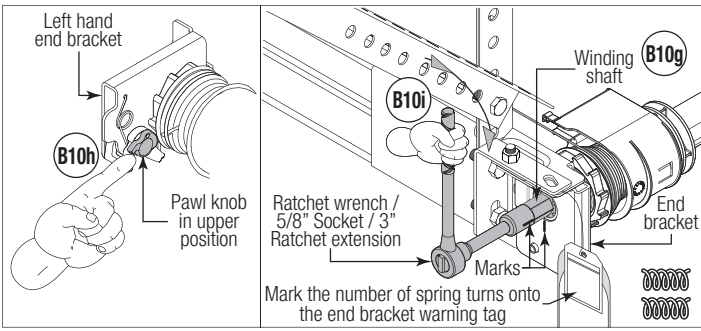

B11 Finish Installing Rear Back Hangs

Tools Required: Ratchet wrench, Socket: 1/2" Wrench: 1/2", 3" Ratchet extension, (2) Locking pliers, Step ladder, Tape measure, Safety glasses, Leather gloves

FINISH INSTALLING THE REAR BACK HANGS, WHICH YOU TEMPORARILY INSTALLED IN STEP B2, THEN PROCEED TO STEP B12.

B12 Attaching Weather Seal

Tools Required: Hammer, Step ladder, Safety glasses, Leather gloves

NOTE: Complete Step A10 now to permanently attach the weatherstrips, then proceed to Step B13.

B13 Securing Drum Wraps

Tools Required: Step ladder, Safety glasses, Leather gloves

IMPORTANT: PULL THE COUNTERBALANCE LIFT CABLE DOWN FROM THE CEILING TO CLEAR THE LATCH, WHILE SIMULTANEOUSLY SLIDING THE DRUM WRAP AGAINST THE LAST RIB UNTIL THE THREE CATCHES ENGAGE THE 3RD RIB.

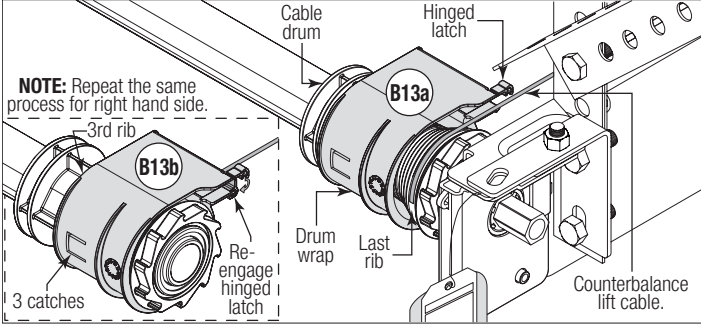

B14 Balancing Door

Tools Required: Ratchet wrench, Socket: 5/8", 3" Ratchet extension, Wrench: 5/8", Locking pliers, Tape measure, Level, Step ladder, Safety glasses, Leather gloves

NOTE: Windows may cause the top section to be significantly heavier than the remaining sections. Wayne Dalton attempts to balance the door at the top and bottom. To prevent any sudden door acceleration between the top and bottom, we recommend motor operating all doors with windows.

Remove any locking pliers. Lift the door and check its balance. Adjust spring(s) if door lifts by itself (hard to pull down) or if door is difficult to lift (drifts down). Anytime spring adjustments are made, ratchet pawl knob must be in the upper position. An unbalanced door can cause TorqueMaster® Plus operation problems.

Close the door and place locking pliers onto both vertical tracks just above the third track roller. This is to prevent the garage door from rising while adjusting the spring(s).

IMPORTANT: TO ADJUST SPRINGS, ONLY ADD OR REMOVE A MAXIMUM OF 3/10 OF A TURN (THREE TEETH ON THE RATCHET WHEEL) AT A TIME. BOTH SIDES NEED TO BE ADJUSTED EQUALLY ON DOUBLE SPRING DOORS.

⚠ WARNING
WINDING SPRING(S) IS AN EXTREMELY DANGEROUS PROCEDURE AND SHOULD BE PERFORMED ONLY BY A TRAINED DOOR SYSTEM TECHNICIAN USING PROPER TOOLS AND INSTRUCTIONS.

ADD SPRING TENSION: The ratchet wheel is made of 10 teeth. To add spring tension, tighten counter clockwise on the right hand side and clockwise on the left hand side. Place pawl knob in upper position. Place the ratchet with 5/8" socket and 3" ratchet extension onto the winding shaft, to add 3/10 of a turn. Watch as three teeth of the ratchet wheel pass over the pawl, creating three "clicks". Place pawl knob in lower position. For double spring applications, repeat the same process for the other side.

REMOVE SPRING TENSION: To remove spring tension, place a regular 5/8" wrench onto the

winding shaft. Place pawl knob in upper position.

IMPORTANT: BE PREPARED TO HOLD THE FULL TENSION OF THE SPRING.

Pull down on the wrench to relieve pressure between the pawl and the ratchet wheel. Push in on the pawl to allow the three ratchet wheel teeth to pass by the pawl, as you carefully allow the wrench to be rotated upward by the spring tension, release the pawl to allow it to engage with the ratchet wheel. Place pawl knob in lower position. For double spring applications, repeat the same process for the other side.

IMPORTANT: DO NOT ADD OR REMOVE MORE THAN 1 SPRING TURN (1 SPRING TURN EQUALS 10 TEETH ON RATCHET WHEEL) FROM THE RECOMMENDED NUMBER OF TURNS SHOWN ON THE WINDING SPRING TURN CHART.

If the door still does not operate easily, lower the door into the closed position, unwind spring(s) completely, and recheck the following items:

- 1.) Is the door level?
- 2.) Are the TorqueMaster® spring tube and flag angles level and plumb?
- 3.) Does the distance between the flag angles equal door width plus 3-3/8" to 3-1/2"?
- 4.) Do the counterbalance lift cables have equal tension? Adjust if necessary.
- 5.) Rewind the spring(s).
- 6.) Make sure door is not rubbing on jambs.

TORSION FRONT MOUNT LHR INSIDE HOOKUP

NOTE: Some graphics in "C" are designated as either single spring applications or double spring applications.

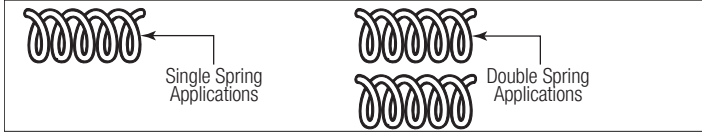

C1 Attaching End Bearing Brackets

Tools Required: Step ladder, Power drill, 3/16" Drill bit, Ratchet wrench, 7/16" Socket driver, 9/16" Socket, 9/16" Wrench, Tape measure, Safety glasses, Leather gloves

NOTE: Right and left hand is always determined from inside the garage looking out.

NOTE: Ensure the 3/8" - 16 x 3/4" truss head bolt is going through the inside portion of flag angle first and the 3/8" - 16 hex nut is on the outside of the flag angle, as shown.

IMPORTANT: SPACING SPECIFIED BELOW MUST BE MAINTAINED BETWEEN THE END BEARING BRACKET AND THE FLAG ANGLE. THIS IS TO ENSURE PROPER CLEARANCE OF THE COUNTERBALANCE LIFT CABLE.

NOTE: Prior to fastening end bearing brackets into the door jamb, pilot drill using a 3/16" drill bit.

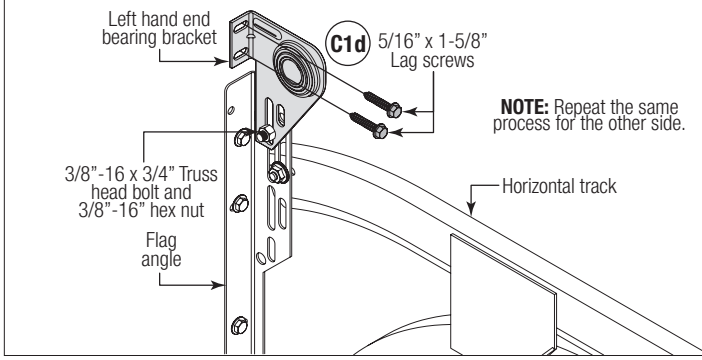
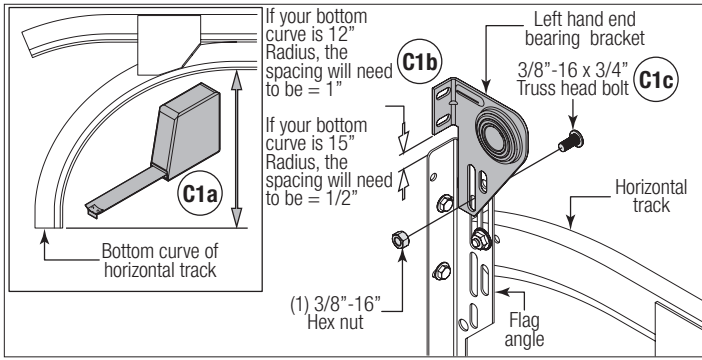

C2

Attaching Center Bracket to Wall

Tools Required: Step ladder, Power drill, 7/16" Socket driver, 3/16" Drill bit, Level, Tape measure, Pencil, Safety glasses, Leather gloves

NOTE: Prior to fastening center bracket(s) to the header, pilot drill using a 3/16" drill bit.

NOTE: On some single spring doors, the spring can be longer than half the opening width. If your spring is longer, then the center bracket must be mounted off center for the spring to fit properly. Measure spring length adding room for spring growth during winding, to determine appropriate center bracket location.

IMPORTANT: USE A 5/16" X 2-1/2" RED HEAD LAG SCREW INSTEAD OF THE 5/16" X 1-5/8" RED HEAD LAG SCREW IF MOUNTING SURFACE IS COVERED BY DRYWALL. THE LAG SCREW MUST BE ATTACHED THROUGH THE BOTTOM HOLE OF THE CENTER BRACKET(S). IF MOUNTING SURFACE IS A 2" X 6" BOARD INSTALLED ON TOP OF MASONRY, DRILL A CLEARANCE HOLE IN MASONRY FOR THE 5/16" X 2-1/2" RED HEAD LAG SCREWS.

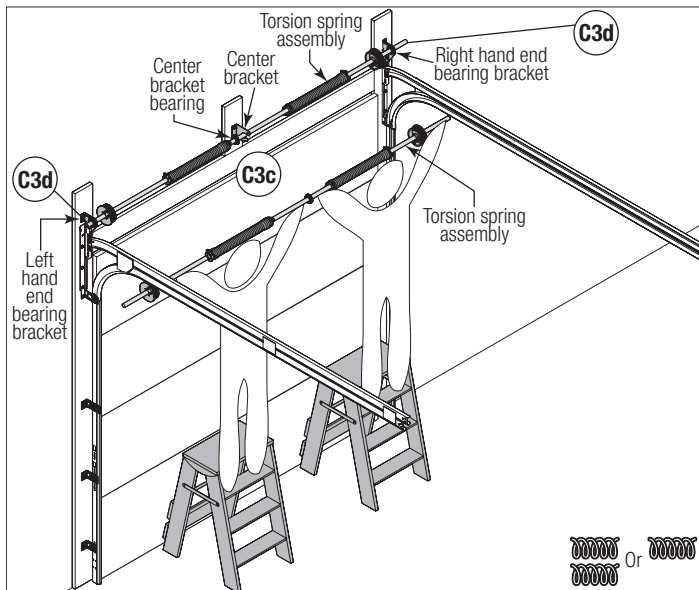
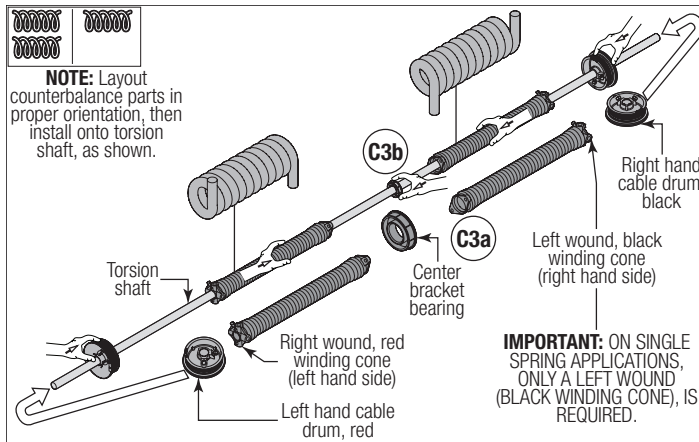
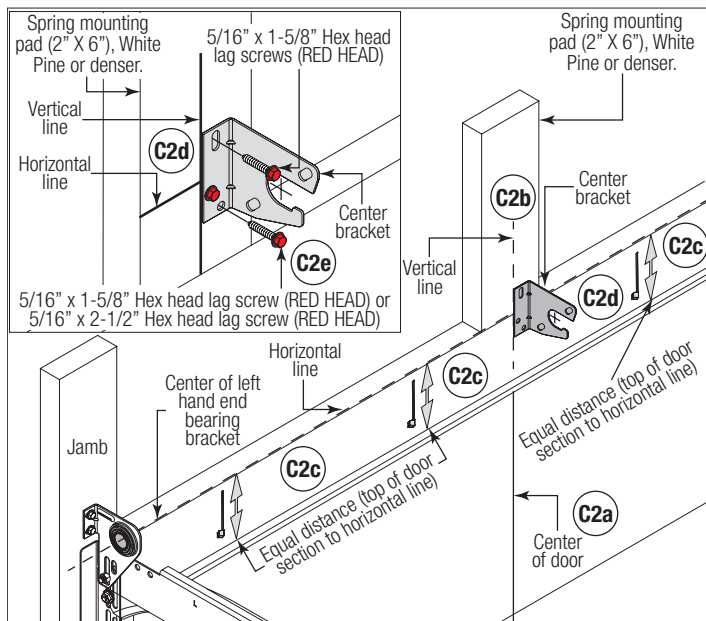

C3

Torsion Spring Assembly

Tools Required: 3/8" Wrench, 9/16" Wrench, Step ladder, Tape measure, Safety glasses, Leather gloves

IMPORTANT: RIGHT AND LEFT HAND IS ALWAYS DETERMINED FROM INSIDE THE BUILDING LOOKING OUT.

IMPORTANT: IDENTIFY THE TORSION SPRINGS PROVIDED AS EITHER RIGHT WOUND (RED WINDING CONE), WHICH GOES ON THE LEFT HAND SIDE OR LEFT WOUND (BLACK WINDING CONE), WHICH GOES ON THE RIGHT HAND SIDE.

IMPORTANT: ON SINGLE SPRING APPLICATIONS, ONLY A LEFT HAND WOUND (BLACK WINDING CONE), IS REQUIRED.

NOTE: The set screws used on all winding cones and cable drums are colored red. DO NOT identify right and left hand by the set screw color.

Facing the inside of the door, lay the torsion shaft on the floor. Lay the torsion spring with the black winding cone and the black cable drum at the right end of the torsion shaft. Lay the torsion spring with the red winding cone and the red cable drum at the left end of the torsion shaft. Slide the center bracket bearing onto the torsion shaft followed by the torsion springs and cable drums.

IMPORTANT: THE CENTER BRACKET BEARING, TORSION SPRING(S) AND CABLE DRUMS MUST BE POSITIONED AND ORIENTED, AS SHOWN.

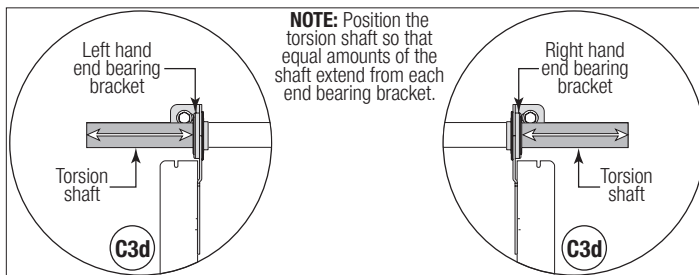

C4

Attaching Springs to Center Bracket

Tools Required: Ratchet Wrench, 9/16" Socket, 9/16" Wrench, Tape measure, Step ladder, Safety glasses, Leather gloves

IMPORTANT: THE SPRING WARNING TAG(S) SUPPLIED MUST BE SECURELY ATTACHED TO THE STATIONARY SPRING CONE(S) IN PLAIN VIEW. SHOULD A REPLACEMENT SPRING WARNING TAG BE REQUIRED, CONTACT WAYNE DALTON FOR FREE REPLACEMENTS.

Slide center bracket bearing into the spring. Align the stationary spring cone(s) with the holes in the center bracket bearing assembly. Secure the torsion spring(s) to the center bracket assembly with (2) 3/8" - 16 x 1-1/2" hex head bolts and (2) 3/8" - 16 nuts.

IMPORTANT: NEVER USE MORE THAN ONE BEARING WHEN ATTACHING TWO SPRINGS TO ONE CENTER BRACKET.

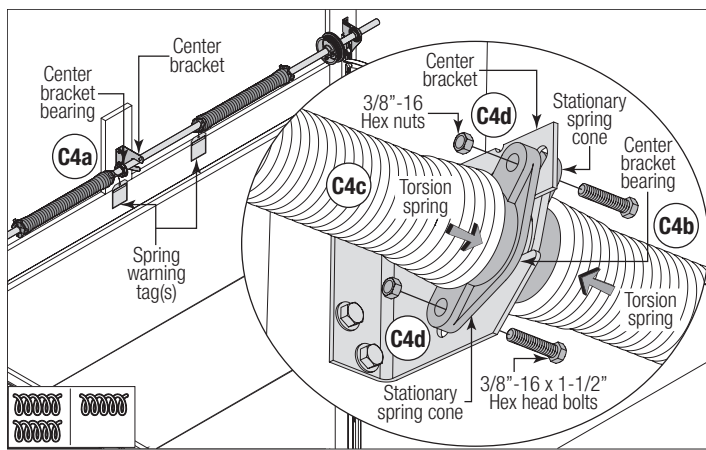

C7 Securing Door for Spring Winding

Tools Required: Locking pliers, Safety glasses, Leather gloves

WARNING
FAILURE TO ENSURE DOOR IS IN A CLOSED POSITION AND TO PLACE LOCKING PLIERS ONTO VERTICAL TRACK CAN ALLOW DOOR TO RISE AND CAUSE SEVERE OR FATAL INJURY.

Winding Bars (Steel Rods)	Size Of Winding Bar (Inches)	Spring Inner Diameter Used On
	1/2" dia. x 18"	2" and 2-5/8"

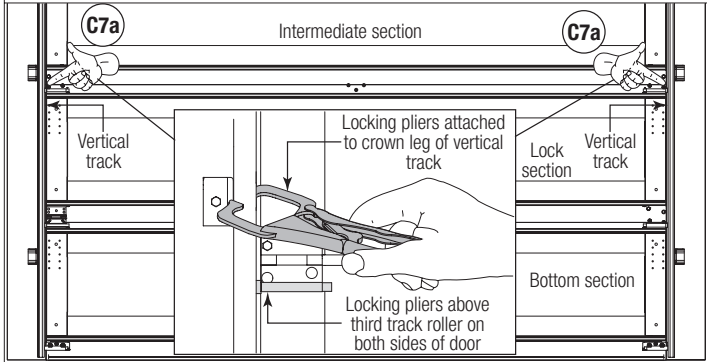

C8 Winding Spring(s)

Tools Required: Step ladder, (2) Approved winding bars, 3/8" Wrench, Tape measure, Safety glasses, Leather gloves

WARNING
WINDING SPRING IS AN EXTREMELY DANGEROUS PROCEDURE AND SHOULD BE PERFORMED ONLY BY A TRAINED DOOR SYSTEM TECHNICIAN USING PROPER TOOLS AND INSTRUCTIONS.

WARNING
USE ONLY SPECIFIED WINDING BARS, AS STATED IN STEP SECURING DOOR FOR SPRING WINDING (C7). DO NOT SUBSTITUTE WITH SCREWDRIVERS, PIPE, ETC. OTHER TOOLS MAY FAIL OR RELEASE FROM THE SPRING CONE AND CAUSE SEVERE OR FATAL INJURY.

WARNING
PRIOR TO WINDING THE SPRING, ENSURE YOU'RE WINDING IN THE PROPER DIRECTION AS SHOWN BELOW. OTHERWISE THE SPRING FITTING MAY RELEASE FROM SPRING AND RESULT IN SEVERE OR FATAL INJURY.

Check the label attached to the spring warning tag for the required number of complete turns to balance your door.

HOW TO WIND TORSION SPRINGS:

1. Insert one winding rod snugly into winding cone, to full socket depth
2. Maintaining a tight grip on the winding rod rotate it slowly in the proper direction, as shown below.
3. If there is any slippage of the winding rod in the winding cone socket, reverse the direction of winding and return the cone to its original position. Remove the winding rod from the winding cone socket. Reseat the winding rod in the socket. Start over at Step #1.
4. When the winding rod is vertical above the winding cone, insert another winding rod into one of the other sockets, being careful to seat it snugly and at full socket depth.
5. Hold the spring with the second winding bar, and remove the first.
6. Repeat Steps #2 through #5 until the complete turns have been applied.

IMPORTANT: AFTER WINDING THE SPRING(S), TIGHTEN THE SET SCREWS IN THE WINDING CONE TO 14-15 FT. LBS. OF TORQUE. ONCE SET SCREWS CONTACT THE TORSION SHAFT, TIGHTEN SCREWS AN ADDITIONAL ONE FULL TURN.

C5 Attaching Counterbalance Lift Cables

Tools Required: 3/8" Wrench, Locking pliers, Tape measure, Step ladder, Safety glasses, Leather gloves

IMPORTANT: VERIFY THAT THERE ARE NO OBSTRUCTIONS IN THE TRAVEL PATH OF THE DOOR SECTIONS OR COUNTERBALANCE LIFT CABLES.

IMPORTANT: INSPECT EACH COUNTERBALANCE LIFT CABLE MAKING SURE IT IS SEATED PROPERLY ONTO THE CABLE DRUM AND THAT BOTH COUNTERBALANCE LIFT CABLES HAVE EQUAL TENSION.

CHECK COUNTERBALANCE LIFT CABLES FOR EQUAL TENSION:

1. Attach locking pliers to track above top roller.
2. Grasp cable at approximate mid-door height location.
3. Draw cable toward you about 1/2" to 1" and release, noting the response of the cable.
4. Repeat above steps for other cable.
5. Adjust cable tension as needed until right and left cables both respond the same.

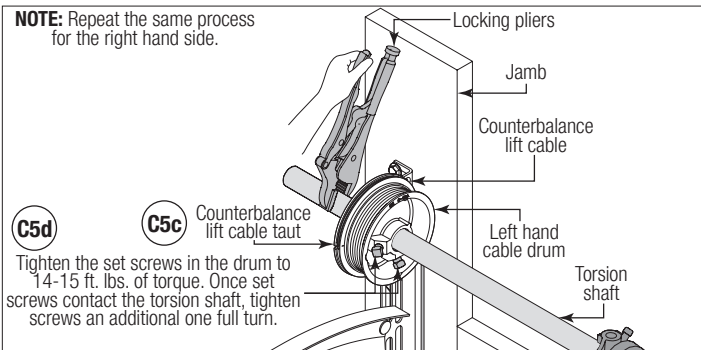
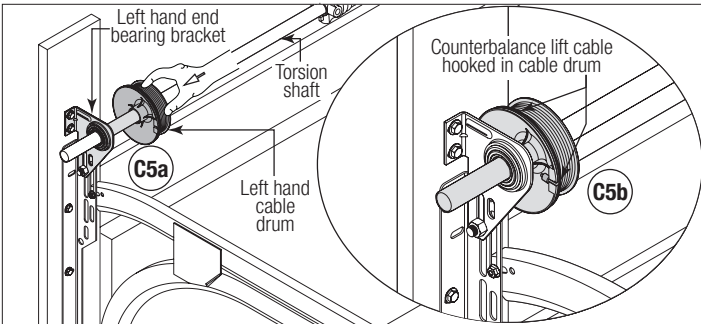

C6 Chalking Torsion Spring(s)

Tools Required: Step ladder, Chalk, Safety glasses, Leather gloves

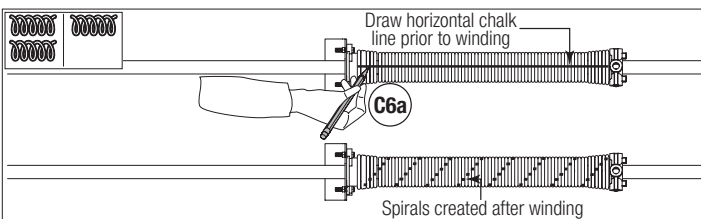

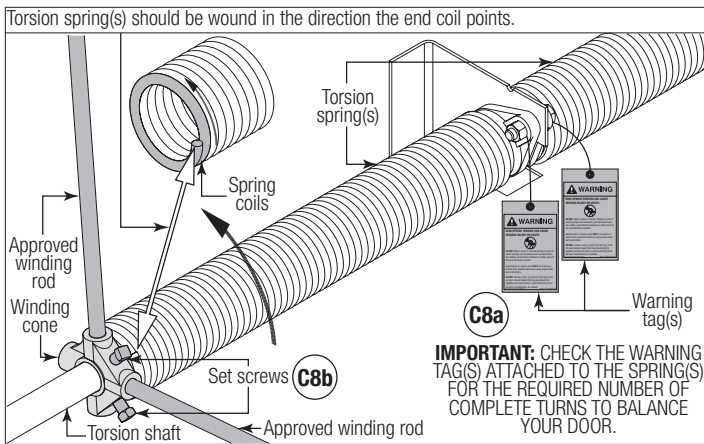

NOTE: Right and left hand is always determined from inside the garage looking out.

NOTE: Identify the end bearing brackets supplied with your door. Refer to Illustrations below, Package Contents or Parts Breakdown, to determine which end bearing brackets you have.

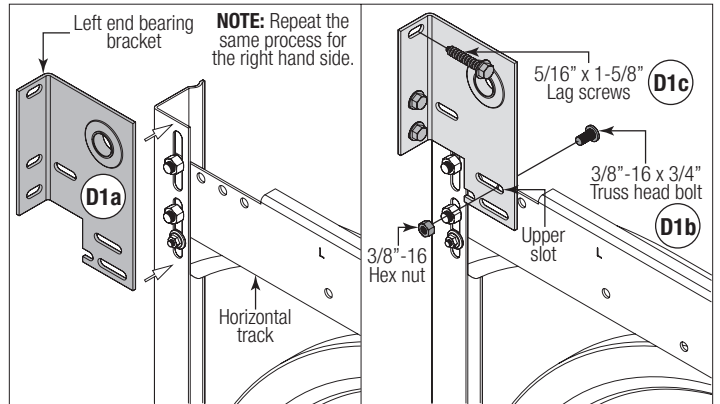
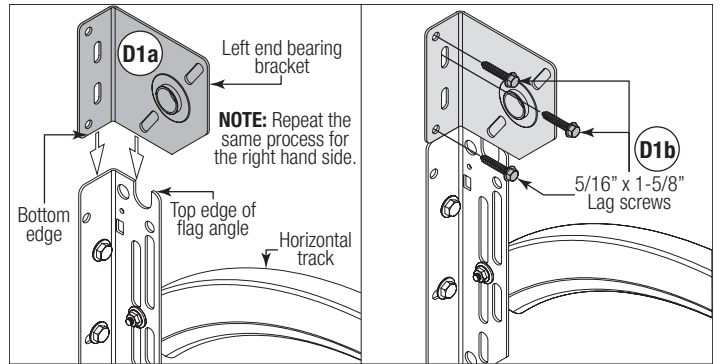

NOTE: Prior to fastening center bracket(s) to the header, pilot drill using a 3/16" drill bit.

NOTE: On some single spring doors, the spring can be longer than half the opening width. If your spring is longer, then the center bracket must be mounted off center for the spring to fit properly. Measure spring length adding room for spring growth during winding, to determine appropriate center bracket location.

IMPORTANT: USE A 5/16" X 2-1/2" RED HEAD LAG SCREW INSTEAD OF THE 5/16" X 1-5/8" RED HEAD LAG SCREW IF MOUNTING SURFACE IS COVERED BY DRYWALL. THE LAG SCREW MUST BE ATTACHED THROUGH THE BOTTOM HOLE OF THE CENTER BRACKET(S). IF MOUNTING SURFACE IS A 2" X 6" BOARD INSTALLED ON TOP OF MASONRY, DRILL A CLEARANCE HOLE IN MASONRY FOR THE 5/16" X 2-1/2" RED HEAD LAG SCREWS.

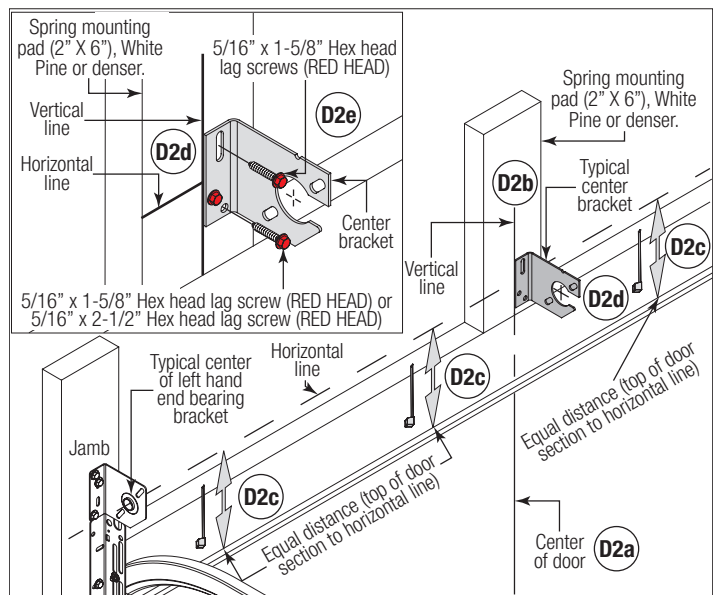

C9 Attaching Rear Back Hangs

Tools Required: Ratchet wrench, Socket: 1/2", Wrench: 1/2", (2) Locking pliers, Tape measure, Level, Step ladder, Safety glasses, Leather gloves

NOTE: Complete Step A9 now to attach the Rear Back Hangs, then proceed to Step C10.

C10 Attaching Weather Seal

Tools Required: Hammer, Step ladder, Safety glasses, Leather gloves

NOTE: Complete Step A10 now to permanently attach the weatherstrips, then proceed to Step C11.

C11 Balancing Door

Tools Required: Step ladder, (2) Approved winding bars, 3/8" Wrench, (2) Locking pliers, Tape measure, Step ladder, Safety glasses, Leather gloves

Remove locking pliers. Lift door and check its balance. Adjustments to the required number of spring turns stated may be necessary. If door rises off floor more than 2 ft. under spring tension alone, reduce spring tension. If the door is hard to rise or drifts down on its own, add spring tension. A poorly balanced door can cause garage door operator problems.

To adjust spring tension, fully close door. Apply locking pliers to track above third track roller. Place locking pliers on torsion shaft, as shown in C5. Insert a winding rod into the winding cone. Push upward on the winding rod slightly while carefully loosening the set screws in the winding cone.

IMPORTANT: BE PREPARED TO SUPPORT THE FULL FORCE OF THE TORSION SPRING ONCE THE SET SCREWS ARE LOOSE.

Carefully adjust spring tension 1/4 turn. Retighten both set screws to 14-15 ft. lbs. of torque in the winding cone and repeat for the other side. Recheck door balance and re-adjust spring tension if needed.

IMPORTANT: DO NOT ADJUST MORE THAN 1 TURN FROM THE RECOMMENDED NUMBER OF TURNS.

If the door still does not operate easily, lower the door into the closed position, unwind spring(s) completely, and recheck the following items:

- 1.) Is the door level?
- 2.) Are the torsion shaft and flag angles level and plumb?
- 3.) Does the distance between the flag angles equal door width plus 3-3/8" to 3-1/2"?
- 4.) Do the counterbalance lift cables have equal tension? Adjust if necessary.
- 5.) Rewind the spring(s).
- 6.) Make sure door is not rubbing on jambs.

IMPORTANT: IF DOOR STILL DOES NOT BALANCE PROPERLY, THEN CONTACT A TRAINED DOOR SYSTEM TECHNICIAN.

TORSION FRONT MOUNT LHR OUTSIDE HOOKUP

NOTE: Some graphics in "D" are designated as either single spring applications or double spring applications.



D1 Attaching End Bearing Brackets

Tools Required: Step ladder, Power drill, 3/16" Drill bit, Ratchet wrench, 7/16" Socket driver, 9/16" Socket, 9/16" Wrench, Tape measure, Safety glasses, Leather gloves

NOTE: If you have any of these components shown in this illustration, refer to the full **Installation Instructions And Owner's Manual** available at no charge from:

- Your local Wayne Dalton Sales Center, or
- Online at www.Wayne-Dalton.com, or
- By mailing to: Wayne Dalton, a division of Overhead Door Corporation, P.O. Box 67, Mt. Hope, OH., 44660.

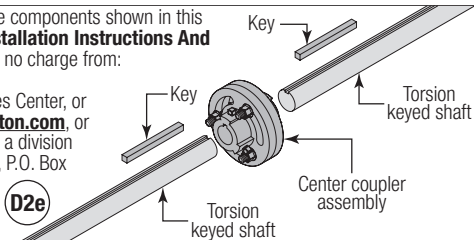

D3

Torsion Spring Assembly

Tools Required: 3/8" Wrench, 9/16" Wrench, Step ladder, Tape measure, Safety glasses, Leather gloves

IMPORTANT: RIGHT AND LEFT HAND IS ALWAYS DETERMINED FROM INSIDE THE BUILDING LOOKING OUT.

IMPORTANT: IDENTIFY THE TORSION SPRINGS PROVIDED AS EITHER RIGHT WOUND (RED WINDING CONE), WHICH GOES ON THE RIGHT HAND SIDE OR LEFT WOUND (BLACK WINDING CONE), WHICH GOES ON THE LEFT HAND SIDE.

IMPORTANT: ON SINGLE SPRING APPLICATIONS, ONLY A LEFT WOUND (BLACK WINDING CONE), WHICH GOES ON THE LEFT HAND SIDE IS REQUIRED.

NOTE: The set screws used on all torsion winding cones and cable drums are colored red. DO NOT identify right and left hand by the set screw color.

Facing the inside of the door, lay the torsion shaft on the floor. Lay the torsion spring with the red winding cone at the right end of the torsion shaft. Lay the torsion spring with the black winding cone at the left end of the torsion shaft. Slide the center bracket bearing onto the torsion shaft followed by the torsion springs and set collars (if applicable).

IMPORTANT: THE CENTER BRACKET BEARING / TORSION SPRING(S) AND THE SET COLLARS (IF APPLICABLE) MUST BE POSITIONED, AS SHOWN.

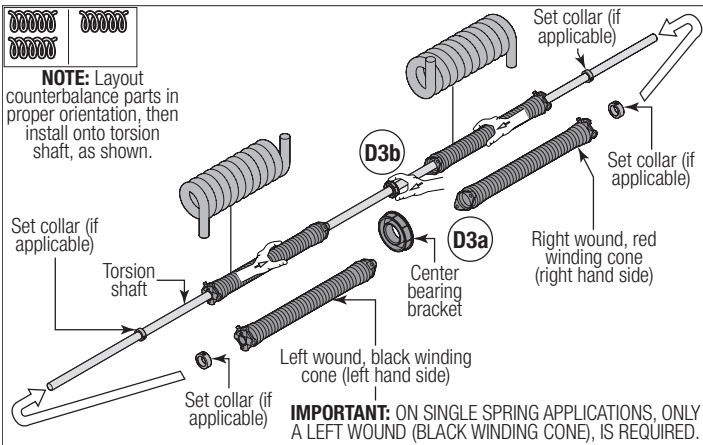

IMPORTANT: ON SINGLE SPRING APPLICATIONS, ONLY A LEFT WOUND (BLACK WINDING CONE), IS REQUIRED.

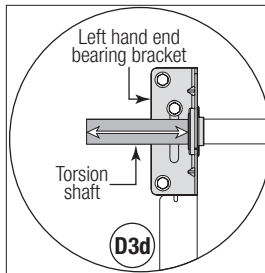
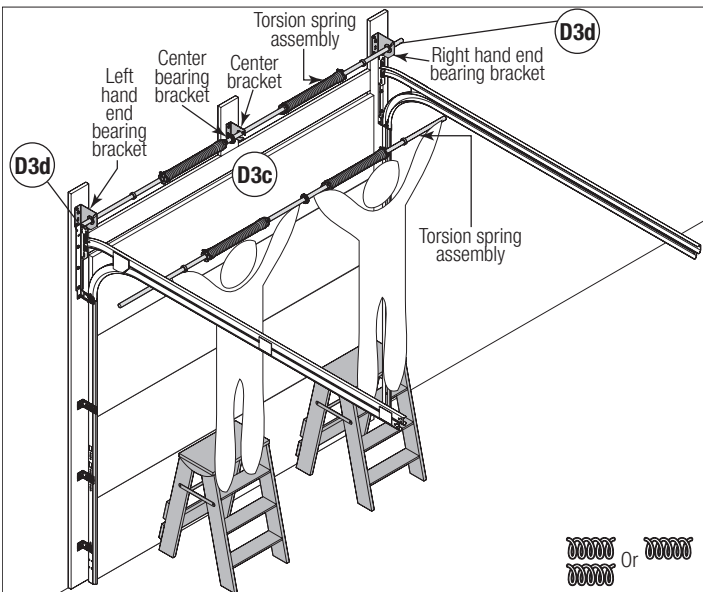

NOTE: Position the torsion shaft so that equal amounts of the shaft extend from each end bearing bracket.

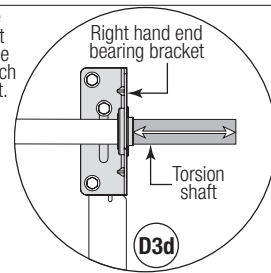

D4

Attaching Springs to Center Bracket

Tools Required: Ratchet Wrench, 9/16" Socket, 9/16" Wrench, Tape measure, Step ladder, Safety glasses, Leather gloves

IMPORTANT: THE SPRING WARNING TAG(S) SUPPLIED MUST BE SECURELY ATTACHED TO THE STATIONARY SPRING CONE(S) IN PLAIN VIEW. SHOULD A REPLACEMENT SPRING WARNING TAG BE REQUIRED, CONTACT WAYNE DALTON FOR FREE REPLACEMENTS.

Slide center bracket bearing into the spring. Align the stationary spring cone(s) with the holes in the center bracket bearing assembly. Secure the torsion spring(s) to the center bracket bearing assembly with (2) 3/8" - 16 x 1-1/2" hex head bolts and (2) 3/8" - 16 nuts.

IMPORTANT: NEVER USE MORE THAN ONE BEARING WHEN ATTACHING TWO SPRINGS TO ONE CENTER BRACKET.

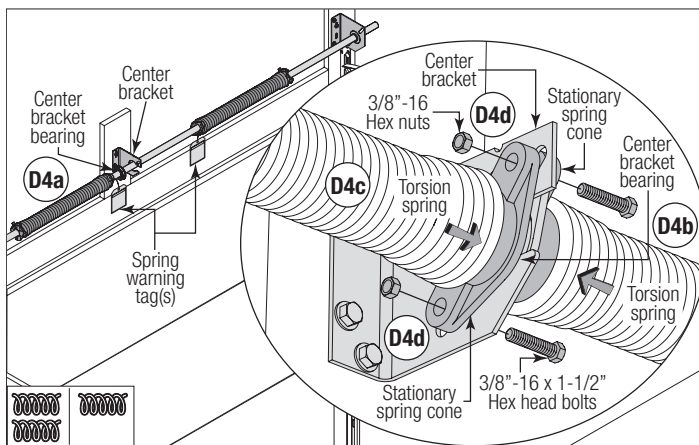

D5

Attaching Counterbalance Lift Cables

Tools Required: 3/8" Wrench, Locking pliers, Tape measure, Step ladder, Safety glasses, Leather gloves

IMPORTANT: VERIFY THAT THERE ARE NO OBSTRUCTIONS IN THE TRAVEL PATH OF THE DOOR SECTIONS OR COUNTERBALANCE LIFT CABLES.

IMPORTANT: INSPECT EACH COUNTERBALANCE LIFT CABLE MAKING SURE IT IS SEATED PROPERLY ONTO THE CABLE DRUM AND THAT BOTH COUNTERBALANCE LIFT CABLES HAVE EQUAL TENSION.

CHECK COUNTERBALANCE LIFT CABLES FOR EQUAL TENSION:

1. Attach locking pliers to track above top roller.
2. Grasp cable at approximate mid-door height location.
3. Draw cable toward you about 1/2" to 1" and release, noting the response of the cable.
4. Repeat above steps for other cable.
5. Adjust cable tension as needed until right and left cables both respond the same.

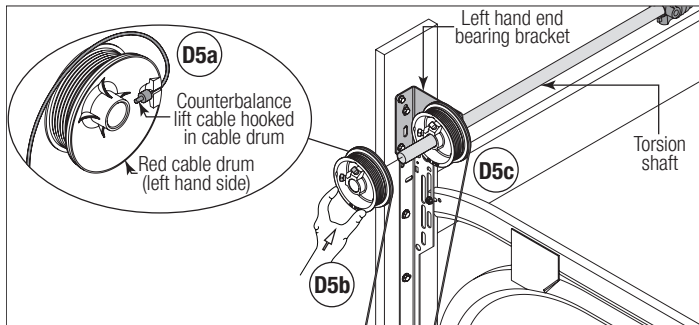

Tighten the set screws in the drum to 14-15 ft. lbs. of torque. Once set screws contact the torsion shaft, tighten screws an additional one full turn.

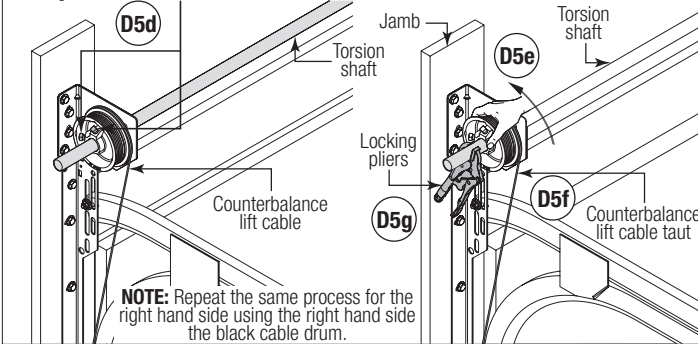

D6

Chalking Torsion Spring(s)

Tools Required: Step ladder, Chalk, Safety glasses, Leather gloves

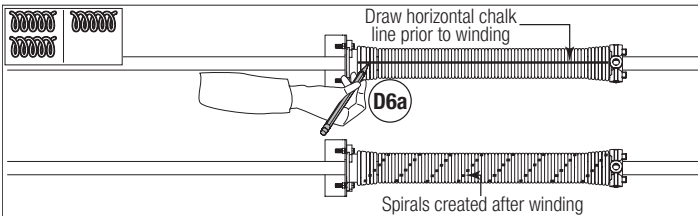

D7

Securing Door for Spring Winding

Tools Required: Locking pliers, Safety glasses, Leather gloves

WARNING

FAILURE TO ENSURE DOOR IS IN A CLOSED POSITION AND TO PLACE LOCKING PLIERS ONTO VERTICAL TRACK CAN ALLOW DOOR TO RISE AND CAUSE SEVERE OR FATAL INJURY.

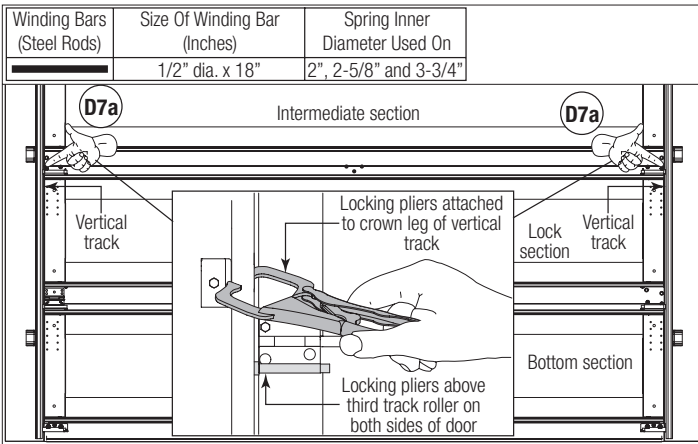

D8

Winding Spring(s)

Tools Required: Step ladder, (2) Approved winding bars, 3/8" Wrench, Tape measure, Safety glasses, Leather gloves

WARNING

WINDING SPRING IS AN EXTREMELY DANGEROUS PROCEDURE AND SHOULD BE PERFORMED ONLY BY A TRAINED DOOR SYSTEM TECHNICIAN USING PROPER TOOLS AND INSTRUCTIONS.

WARNING

USE ONLY SPECIFIED WINDING BARS, AS STATED IN STEP SECURING DOOR FOR SPRING WINDING (D8). DO NOT SUBSTITUTE WITH SCREWDRIVERS, PIPE, ETC. OTHER TOOLS MAY FAIL OR RELEASE FROM THE SPRING CONE AND CAUSE SEVERE OR FATAL INJURY.

WARNING

PRIOR TO WINDING THE SPRING, ENSURE YOU'RE WINDING IN THE PROPER DIRECTION AS SHOWN BELOW. OTHERWISE THE SPRING FITTING MAY RELEASE FROM SPRING AND RESULT IN SEVERE OR FATAL INJURY.

Check the label attached to the spring warning tag for the required number of complete turns to balance your door.

HOW TO WIND TORSION SPRINGS:

1. Insert one winding rod snugly into winding cone, to full socket depth
2. Maintaining a tight grip on the winding rod rotate it slowly in the proper direction, as shown below.
3. If there is any slippage of the winding rod in the winding cone socket, reverse the direction of winding and return the cone to its original position. Remove the winding rod from the winding cone socket. Reseat the winding rod in the socket. Start over at Step #1.
4. When the winding rod is vertical above the winding cone, insert another winding rod into one of the other sockets, being careful to seat it snugly and at full socket depth.
5. Hold the spring with the second winding bar, and remove the first.
6. Repeat Steps #2 through #5 until the complete turns have been applied.

IMPORTANT: AFTER WINDING THE SPRING(S), TIGHTEN THE SET SCREWS IN THE WINDING CONE TO 14-15 FT. LBS. OF TORQUE. ONCE SET SCREWS CONTACT THE TORSION SHAFT, TIGHTEN SCREWS AN ADDITIONAL ONE FULL TURN.

Torsion spring(s) should be wound in the direction the end coil points.

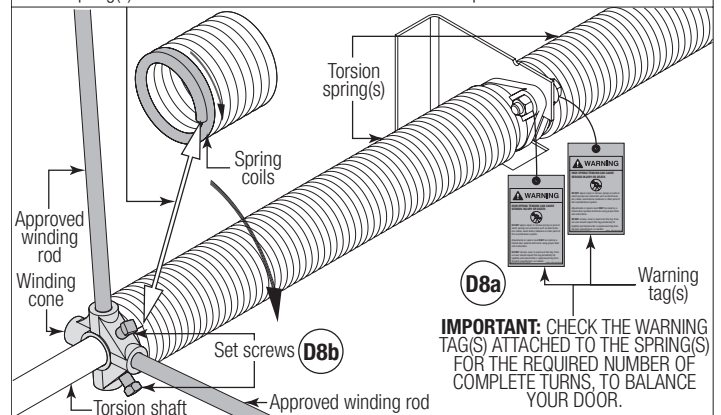

D9

Attaching Rear Back Hangs

Tools Required: Ratchet wrench, Socket: 1/2", Wrench: 1/2", (2) Locking pliers, Tape measure, Level, Step ladder, Safety glasses, Leather gloves

NOTE: Complete Step A9 now to attach the Rear Back Hangs, then proceed to Step D10.

D10

Attaching Weather Seal

Tools Required: Hammer, Step ladder, Safety glasses, Leather gloves

NOTE: Complete Step A10 now to permanently attach the weatherstrips, then proceed to Step D11.

D11

Balancing Door

Tools Required: Step ladder, (2) Approved winding bars, 3/8" Wrench, Locking pliers, Tape measure, Step ladder, Safety glasses, Leather gloves

Remove locking pliers. Lift door and check its balance. Adjustments to the required number of spring turns stated may be necessary. If door rises off floor more than 2 ft. under spring tension alone, reduce spring tension. If the door is hard to rise or drifts down on its own, add spring tension. A poorly balanced door can cause garage door operator problems.

To adjust spring tension, fully close door. Apply locking pliers to track above third track roller. Place locking pliers on torsion shaft, as shown in D5. Insert a winding rod into the winding cone. Push downward on the winding rod slightly while carefully loosening the set screws in the winding cone.

IMPORTANT: BE PREPARED TO SUPPORT THE FULL FORCE OF THE TORSION SPRING ONCE THE SET SCREWS ARE LOOSE.

Carefully adjust spring tension 1/4 turn. Retighten both set screws to 14-15 ft. lbs. of torque in the winding cone and repeat for the other side. Recheck door balance and re-adjust spring tension if needed.

IMPORTANT: DO NOT ADJUST MORE THAN 1 TURN FROM THE RECOMMENDED NUMBER OF TURNS.

If the door still does not operate easily, lower the door into the closed position, unwind spring(s) completely, and recheck the following items:

- 1.) Is the door level?

- 2.) Are the torsion shaft and flag angles level and plumb?
- 3.) Does the distance between the flag angles equal door width plus 3-3/8" to 3-1/2"?
- 4.) Do the counterbalance lift cables have equal tension? Adjust if necessary.
- 5.) Rewind the spring(s).
- 6.) Make sure door is not rubbing on jambs.

IMPORTANT: IF DOOR STILL DOES NOT BALANCE PROPERLY, THEN CONTACT A TRAINED DOOR SYSTEM TECHNICIAN.

TORSION REAR MOUNT LHR OUTSIDE HOOKUP

NOTE: Some graphics in "E" are designated as either single spring applications or double spring applications.



E1

Attaching Cable Lift Sheaves

Tools Required: Ratchet wrench, Socket: 1/2" 9/16", Wrench: 1/2" 9/16", (2) Locking pliers, Tape measure, Level, Step ladder, Safety glasses, Leather gloves

FOR 3" OR 4" SHEAVES, WITH NO SHEAVE SADDLE:

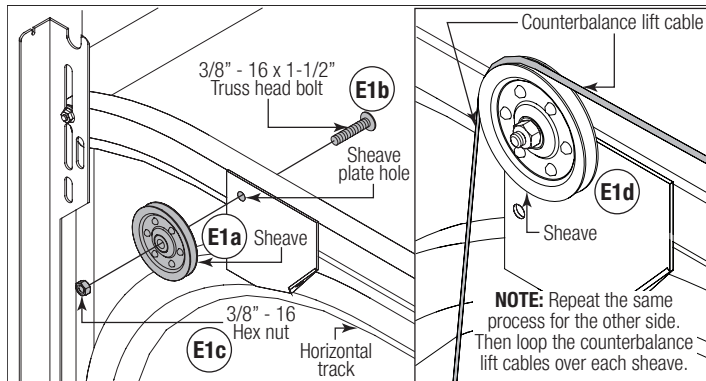

FOR 5" SHEAVES, WITH SHEAVE SADDLE:

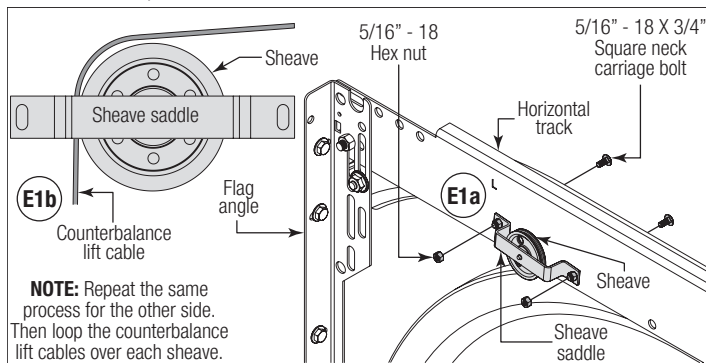

E2

Attaching Rear Back Hangs

Tools Required: Ratchet wrench, Socket: 1/2", Wrench: 1/2", (2) Locking pliers, Tape measure, Level, Step ladder, Safety glasses, Leather gloves

NOTE: Temporarily support the horizontal track with rear back hangs as shown in Step A9, without lifting door and then proceed to Step E3.

E3

Torsion Spring Assembly

Tools Required: 3/8" Wrench, 9/16" Wrench, Step ladder, Tape measure, Safety glasses, Leather gloves

IMPORTANT: RIGHT AND LEFT HAND IS ALWAYS DETERMINED FROM INSIDE THE BUILDING LOOKING OUT.

IMPORTANT: IDENTIFY THE TORSION SPRINGS PROVIDED AS EITHER RIGHT WOUND (RED WINDING CONE) OR LEFT WOUND (BLACK WINDING CONE).

IMPORTANT: ON SINGLE SPRING APPLICATIONS, ONLY A LEFT WOUND (BLACK WINDING CONE), IS REQUIRED.

NOTE: The set screws used on all torsion winding cones and cable drums are colored red. DO NOT identify right and left hand by the set screw color.

Facing the inside of the door, lay the torsion shaft on the floor. Using the images below, layout the torsions springs and the oval bearing (if applicable). Next, slide the oval bearing (if applicable) onto the torsion shaft followed by the torsion spring(s).

IMPORTANT: THE OVAL BEARING AND THE TORSION SPRING(S) MUST BE POSITIONED, AS SHOWN.

NOTE: If applicable, it is recommended that 5/16" lag screws are pilot drilled using a 3/16" drill bit, prior to fastening the center bracket to the ceiling.

NOTE: On some single spring doors, the spring can be longer than half the opening width. If your spring is longer, then the center bracket must be mounted off center for the spring to fit properly.

Measure spring length adding room for spring growth during winding, to determine appropriate center bracket location. Referring to Step, Rear Back Hangs either secure the center bearing bracket(s) to the ceiling using perforated angle at the center of the opening width using 3/8" - 16 x 3/4" hex head bolts and nuts (not supplied) or to wood blocking (adequate framing member(s)) at the center of the opening width using 5/16" RED HEAD lag screws.

IMPORTANT: USE A 5/16" X 2-1/2" RED HEAD LAG SCREW INSTEAD OF THE 5/16" X 1-5/8" RED HEAD LAG SCREW IF MOUNTING SURFACE IS COVERED BY DRYWALL. THE LAG SCREW MUST BE ATTACHED THROUGH THE BOTTOM HOLE OF THE CENTER BRACKET(S).

With assistance, pick up the torsion spring assembly and slide one end of the shaft through the end bearing bracket. Extend the shaft through the bearing until the opposite end of the shaft can be inserted into the other end bearing bracket. Lay the middle of the shaft into the center bracket (if applicable). If your door came with oval bearing(s), loosely attach the oval bearing to the center bracket with (2) 3/8" - 16 x 1-1/2" hex head bolts and (2) 3/8" - 16 hex nuts, as shown. Repeat for others, if needed.

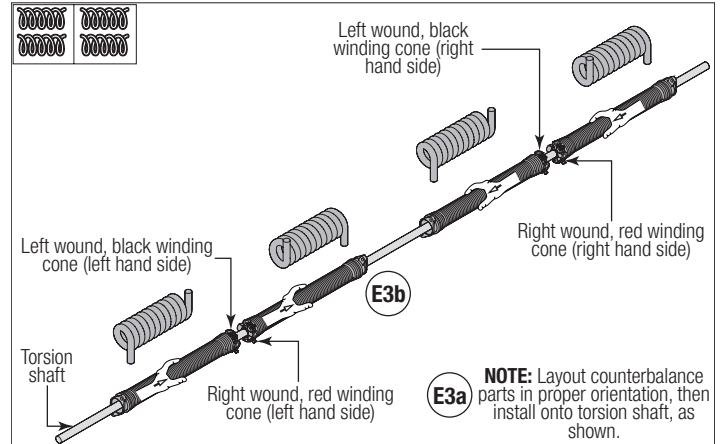
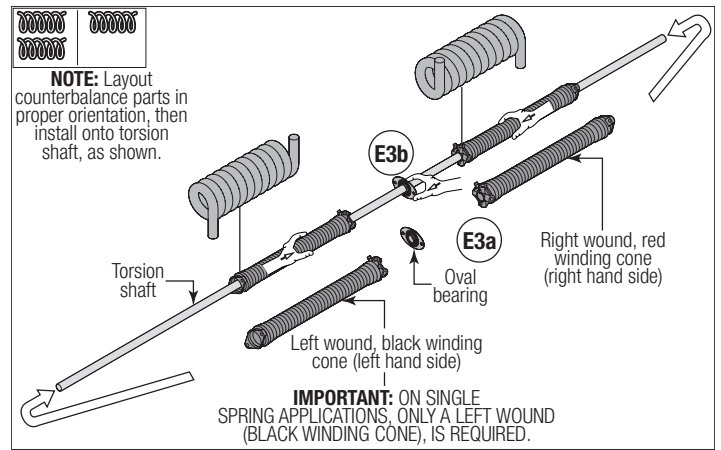

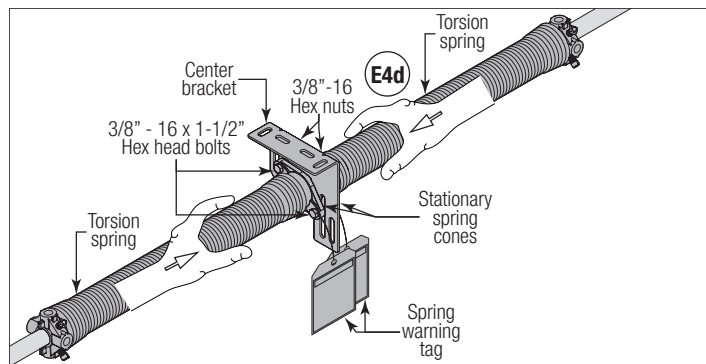
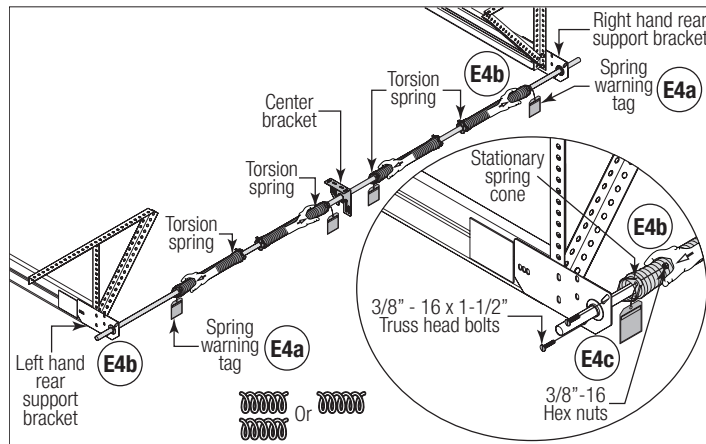
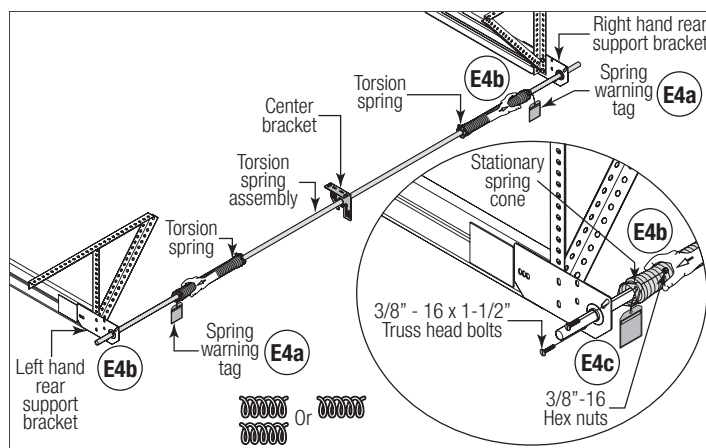
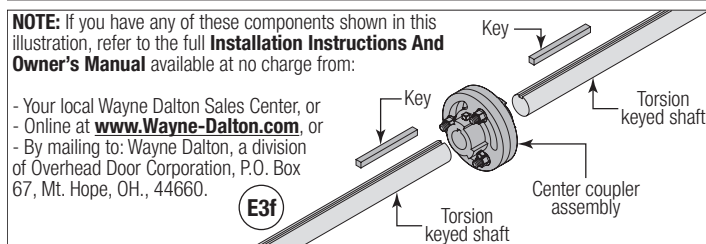
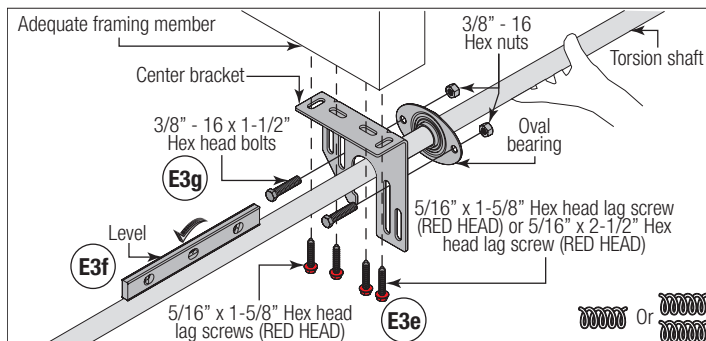
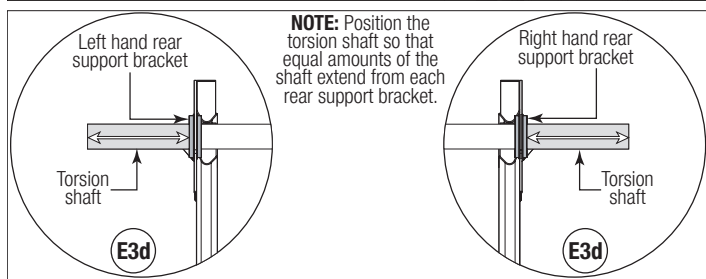
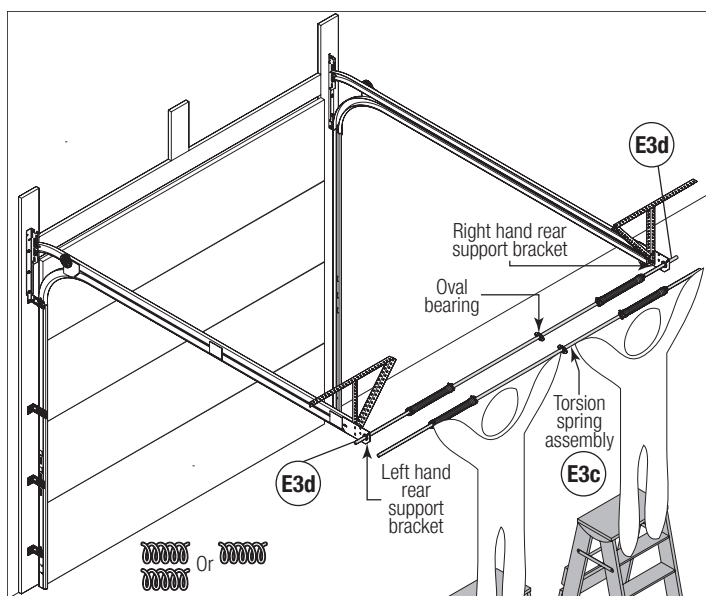

E5 Attaching Counterbalance Lift Cables

Tools Required: 3/8" Wrench, Locking pliers, Tape measure, Step ladder, Safety glasses, Leather gloves

IMPORTANT: VERIFY THAT THERE ARE NO OBSTRUCTIONS IN THE TRAVEL PATH OF THE DOOR SECTIONS OR COUNTERBALANCE LIFT CABLES.

IMPORTANT: INSPECT EACH COUNTERBALANCE LIFT CABLE MAKING SURE IT IS SEATED PROPERLY ONTO THE CABLE DRUM AND THAT BOTH COUNTERBALANCE LIFT CABLES HAVE EQUAL TENSION.

CHECK COUNTERBALANCE LIFT CABLES FOR EQUAL TENSION:

1. Attach locking pliers to track above top roller.
2. Grasp cable at approximate mid-door height location.
3. Draw cable downward to you about 1/2" to 1" and release, noting the response of the cable.
4. Repeat above steps for other cable.
5. Adjust cable tension as needed until right and left cables both respond the same.

E4 Attaching Torsion Spring

Tools Required: Ratchet Wrench, 9/16" Socket, 9/16" Wrench, Tape measure, Step ladder, Safety glasses, Leather gloves

IMPORTANT: THE SPRING WARNING TAG(S) SUPPLIED MUST BE SECURELY ATTACHED TO THE STATIONARY SPRING CONE(S) IN PLAIN VIEW. SHOULD A REPLACEMENT SPRING WARNING TAG BE REQUIRED, CONTACT WAYNE DALTON FOR FREE REPLACEMENTS.

Slide the torsion spring(s) towards the rear support bracket. Align the stationary spring cone(s) with the holes in the rear support bracket. Secure the torsion spring(s) to the rear support bracket with (2) 3/8" - 16 x 1-1/2" truss head bolts and (2) 3/8" - 16 nuts.

NOTE: If you have 4 springs, secure the torsion spring(s) to the center bracket with (2) 3/8" - 16 x 1-1/2" hex head bolts and (2) 3/8" - 16 nuts.

IMPORTANT: NEVER USE MORE THAN ONE BEARING WHEN ATTACHING TWO SPRINGS TO ONE CENTER BRACKET.

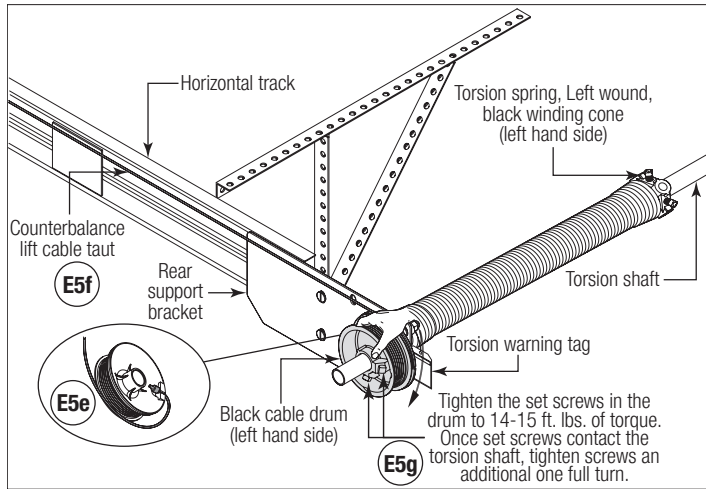
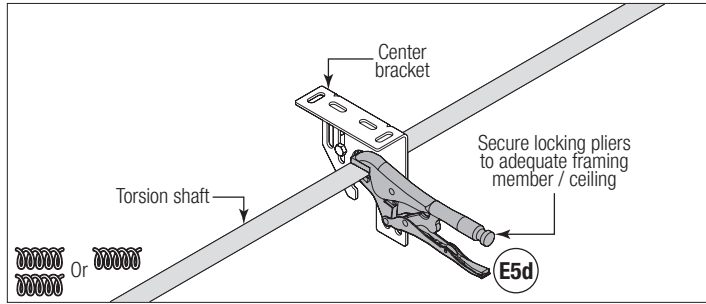
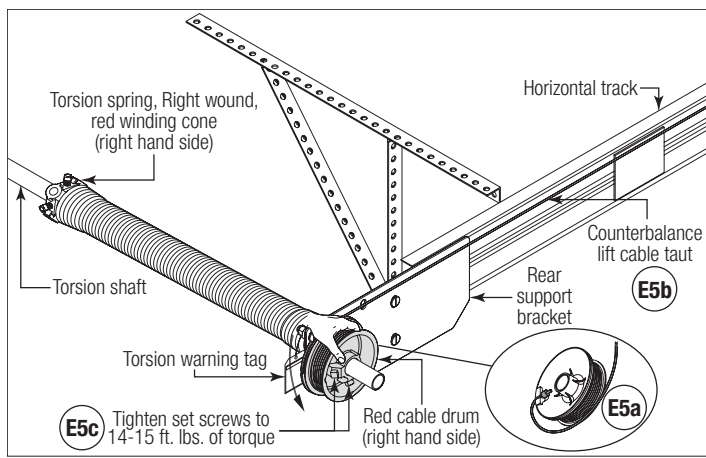

Winding Bars (Steel Rods)	Size Of Winding Bar (Inches)	Spring Inner Diameter Used On
	1/2" dia. x 18"	2" and 2-5/8"

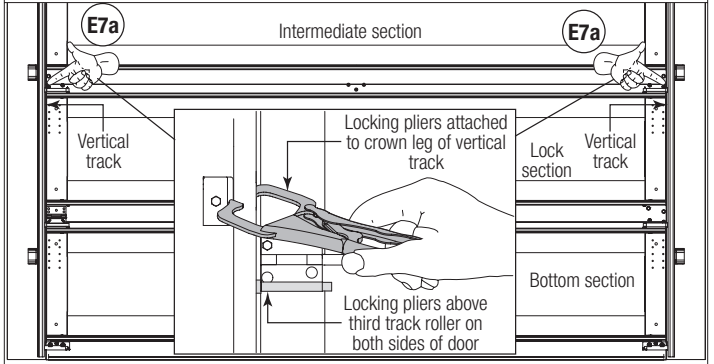

E8 Winding Spring(s)

Tools Required: Step ladder, (2) Approved winding bars, 3/8" Wrench, Tape measure, Safety glasses, Leather gloves

WARNING
WINDING SPRING IS AN EXTREMELY DANGEROUS PROCEDURE AND SHOULD BE PERFORMED ONLY BY A TRAINED DOOR SYSTEM TECHNICIAN USING PROPER TOOLS AND INSTRUCTIONS.

WARNING
USE ONLY SPECIFIED WINDING BARS, AS STATED IN STEP SECURING DOOR FOR SPRING WINDING (E7). DO NOT SUBSTITUTE WITH SCREWDRIVERS, PIPE, ETC. OTHER TOOLS MAY FAIL OR RELEASE FROM THE SPRING CONE AND CAUSE SEVERE OR FATAL INJURY.

WARNING
PRIOR TO WINDING THE SPRING, ENSURE YOU'RE WINDING IN THE PROPER DIRECTION AS SHOWN BELOW. OTHERWISE THE SPRING FITTING MAY RELEASE FROM SPRING AND RESULT IN SEVERE OR FATAL INJURY.

Check the label attached to the spring warning tag for the required number of complete turns to balance your door.

HOW TO WIND TORSION SPRINGS:

1. Insert one winding rod snugly into winding cone, to full socket depth.
2. Maintaining a tight grip on the winding rod rotate it slowly in the proper direction, as shown below.
3. If there is any slippage of the winding rod in the winding cone socket, reverse the direction of winding and return the cone to its original position. Remove the winding rod from the winding cone socket. Reseat the winding rod in the socket. Start over at Step #1.
4. When the winding rod is vertical above the winding cone, insert another winding rod into one of the other sockets, being careful to seat it snugly and at full socket depth.
5. Hold the spring with the second winding bar, and remove the first.
6. Repeat Steps #2 through #5 until the complete turns have been applied.

IMPORTANT: AFTER WINDING THE SPRING(S), TIGHTEN THE SET SCREWS IN THE WINDING CONE TO 14-15 FT. LBS. OF TORQUE. ONCE SET SCREWS CONTACT THE TORSION SHAFT, TIGHTEN SCREWS AN ADDITIONAL ONE FULL TURN.

E6 Chalking Torsion Spring(s)

Tools Required: Step ladder, Chalk, Safety glasses, Leather gloves

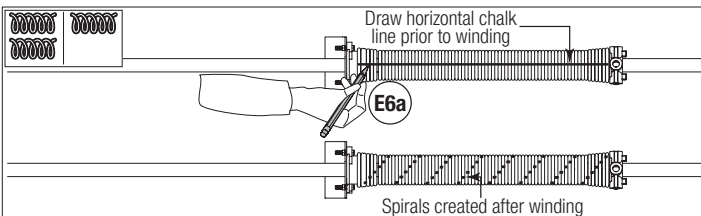

E7 Securing Door for Spring Winding

Tools Required: Locking pliers, Safety glasses, Leather gloves

WARNING
FAILURE TO ENSURE DOOR IS IN A CLOSED POSITION AND TO PLACE LOCKING PLIERS ONTO VERTICAL TRACK CAN ALLOW DOOR TO RISE AND CAUSE SEVERE OR FATAL INJURY.

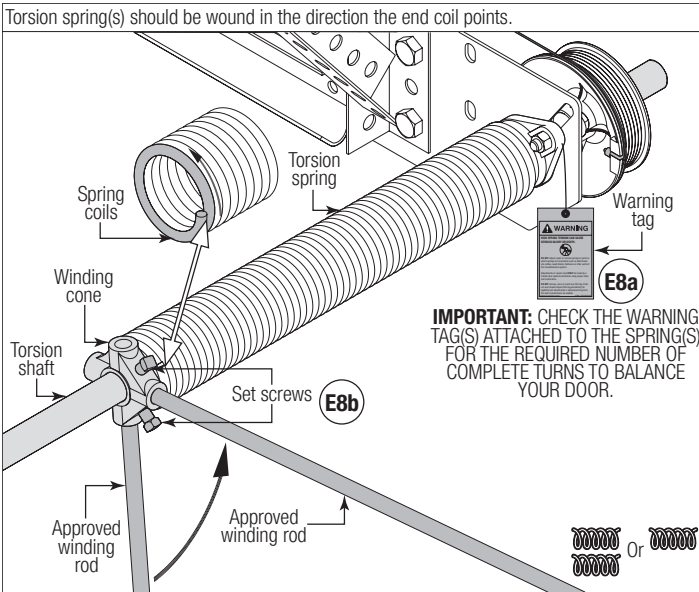

without lifting door and then proceed to Step F2. Adjust the rear back hangs after springs are installed.

Using the chart below, select the appropriate perforated angle (may not be supplied). Fabricate and install rear back hangs, as shown.

Perforated Angle Gauge Weight Limitations For Extension Springs:	
Perforated Angle Gauge	Door Balance Weight
2" x 2" x 12 Gauge	Less Than 400 lbs.
1-1/4" x 1-1/4" x 13 Gauge	Less Than 175 lbs.

⚠ WARNING

MAKE SURE BACK HANGS ARE BRACED SUFFICIENTLY TO RESIST ANY MOTION DURING SPRING APPLICATION AND DOOR TRAVEL. IF BACK HANGS PIVOT OR DEFLECT, ADD REINFORCEMENT UNTIL THEY REMAIN FIRM AND STATIONARY. ANY BACK HANG THAT HAS BENT MUST BE REPLACED.

⚠ WARNING

KEEP HORIZONTAL TRACKS PARALLEL AND WITHIN 3/4" TO 7/8" FROM DOOR EDGE, OTHERWISE DOOR COULD FALL, RESULTING IN SEVERE OR FATAL INJURY.

⚠ WARNING

FAILURE TO ASSEMBLE AND ATTACH REAR BACK HANGS PROPERLY ACCORDING TO THE ABOVE INSTRUCTIONS MAY RESULT IN DOOR FALLING WHEN RAISED, CAUSING SEVERE OR FATAL INJURY.

E9

Finish installing Rear Back Hangs

Tools Required: Ratchet wrench, Socket: 1/2", Wrench: 1/2", (2) Locking pliers, Tape measure, Level, Step ladder, Safety glasses, Leather gloves

NOTE: Complete Step A9 now to attach the Rear Back Hangs, then proceed to Step E10.

E10

Attaching Weather Seal

Tools Required: Hammer, Step ladder, Safety glasses, Leather gloves

NOTE: Complete Step A10 now to permanently attach the weatherstrips, then proceed to Step E11.

E11

Balancing Door

Tools Required: Step ladder, (2) Approved winding bars, 3/8" Wrench, Locking pliers, Tape measure, Step ladder, Safety glasses, Leather gloves

Remove locking pliers. Lift door and check its balance. Adjustments to the required number of spring turns stated may be necessary. If door rises off floor more than 2 ft. under spring tension alone, reduce spring tension. If the door is hard to rise or drifts down on its own, add spring tension. A poorly balanced door can cause garage door operator problems.

To adjust spring tension, fully close door. Apply locking pliers to track above third track roller. Place locking pliers on torsion shaft, as shown in E5. Insert a winding rod into the winding cone. Push upward on the winding rod slightly while carefully loosening the set screws in the winding cone.

IMPORTANT: BE PREPARED TO SUPPORT THE FULL FORCE OF THE TORSION SPRING ONCE THE SET SCREWS ARE LOOSE.

Carefully adjust spring tension 1/4 turn. Retighten both set screws to 14-15 ft. lbs. of torque in the winding cone and repeat for the other side. Recheck door balance and re-adjust spring tension if needed.

IMPORTANT: DO NOT ADJUST MORE THAN 1 TURN FROM THE RECOMMENDED NUMBER OF TURNS.

If the door still does not operate easily, lower the door into the closed position, unwind spring(s) completely, and recheck the following items:

- 1.) Is the door level?
- 2.) Are the torsion shaft and flag angles level and plumb?
- 3.) Does the distance between the flag angles equal door width plus 3-3/8" to 3-1/2"?
- 4.) Do the counterbalance lift cables have equal tension? Adjust if necessary.
- 5.) Rewind the spring(s).
- 6.) Make sure door is not rubbing on jambs.

IMPORTANT: IF DOOR STILL DOES NOT BALANCE PROPERLY, THEN CONTACT A TRAINED DOOR SYSTEM TECHNICIAN.

EXTENSION LHR

F1

Attaching Rear Back Hangs

Tools Required: Ratchet wrench, Socket: 1/2", Wrench: 1/2", (2) Locking pliers, Tape measure, Level, Step ladder, Safety glasses, Leather gloves

NOTE: Temporarily support the horizontal track with rear back hangs as shown below,

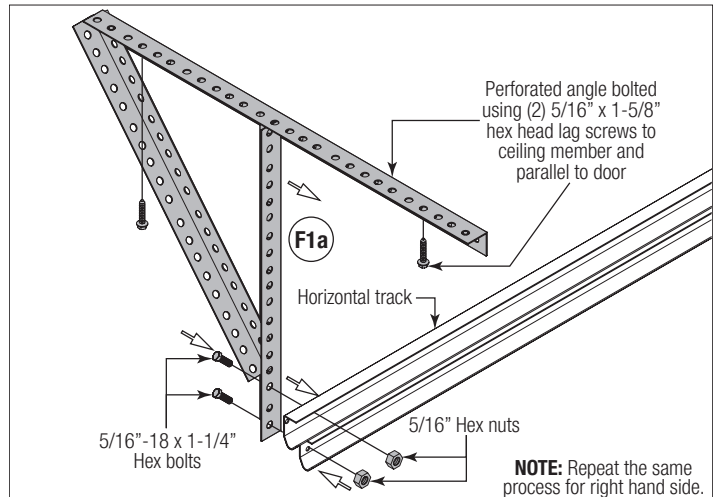
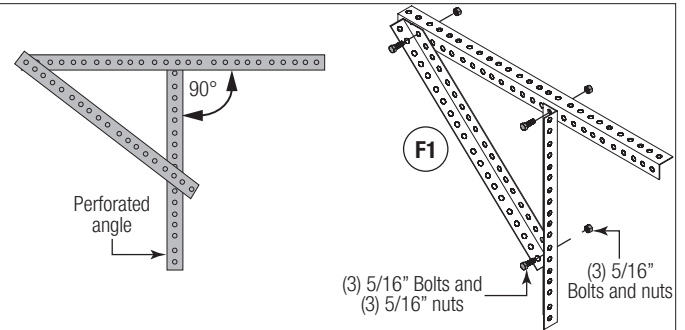

F2

Attaching Front Cable Lift Sheaves

Tools Required: 9/16" Wrench, Locking pliers, Tape measure, Level, Step ladder, Safety glasses, Leather gloves

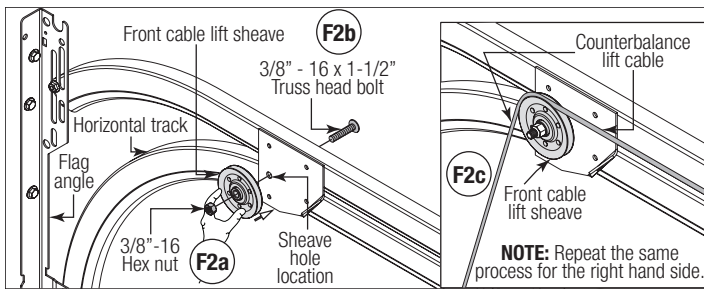

F3

Attaching Extension Springs

Tools Required: Power drill, 3/16" Drill bit, 7/16" Socket driver, 1/2" Wrench, Locking pliers, Tape measure, Level, Step ladder, Safety glasses, Leather gloves

WARNING

WITH ASSISTANCE, RAISE THE DOOR SLOWLY INTO THE OPEN POSITION MAKING SURE THE DOOR TRAVELS SMOOTHLY THROUGH THE TRACKS. CLAMP LOCKING PLIERS TO THE BACK LEG OF BOTH HORIZONTAL TRACKS, BELOW THE BOTTOM TRACK ROLLERS TO KEEP THE DOOR FROM LOWERING.

WARNING

FAILURE TO INSTALL SPRING RESTRAINT CABLES CAN RESULT IN SEVERE OR FATAL INJURY IN CASE OF SPRING BREAKAGE.

NOTE: Some larger doors feature 2 pairs of extension springs. A spring restraint cable must be installed through each spring.

IMPORTANT: SPRING RESTRAINT CABLES MUST BE TAUT AND EQUALIZED.

NOTE: This illustration shows the outside of the door in the open position.

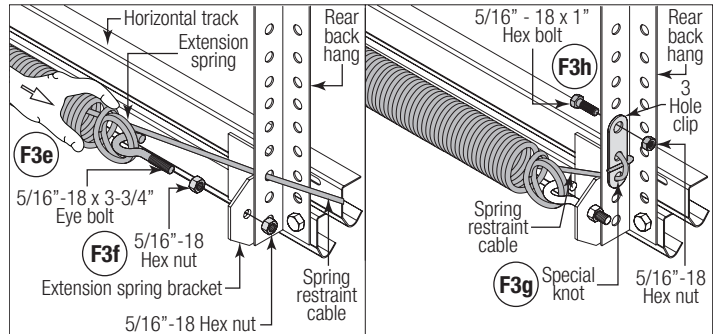
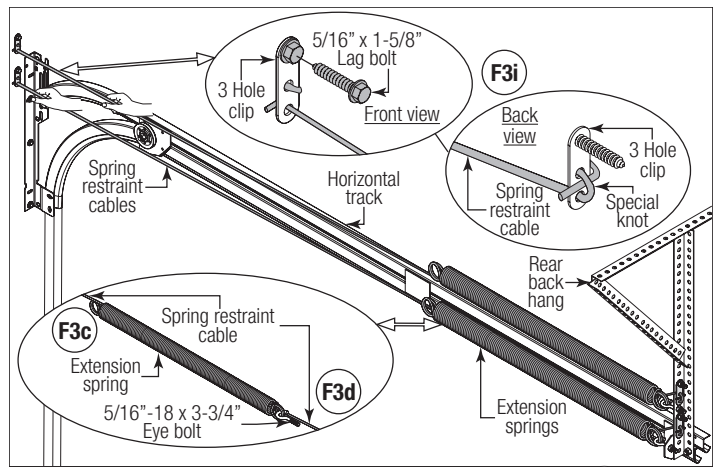
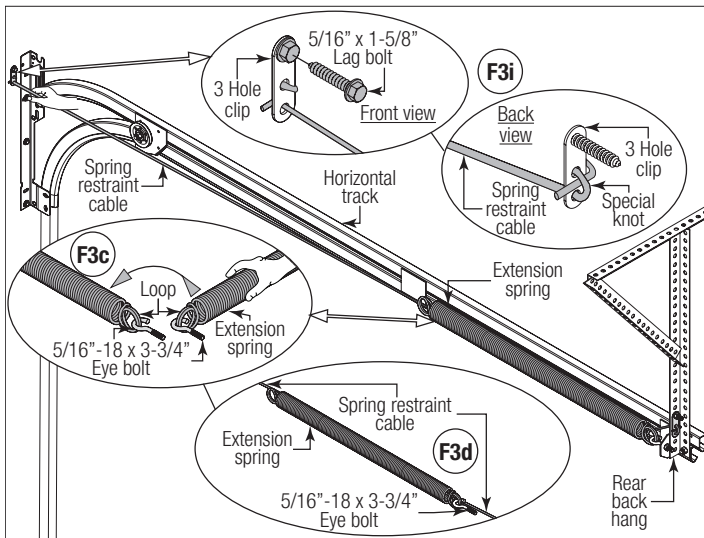
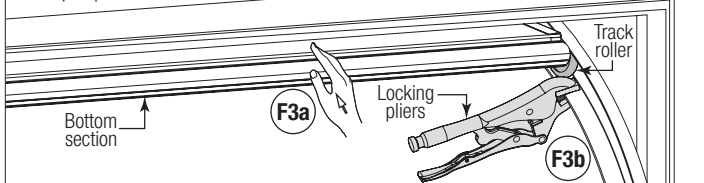

NOTE: As an option, eyebolt may be fastened to rear back hangs and extension spring bracket left unused. The extension spring bracket is useful in applications where rear headroom is small, resulting in short rear back hangs.

F4

Attaching Spring Sheaves

Tools Required: 9/16" Wrench, Tape measure, Level, Locking pliers, Step ladder, Safety glasses, Leather gloves

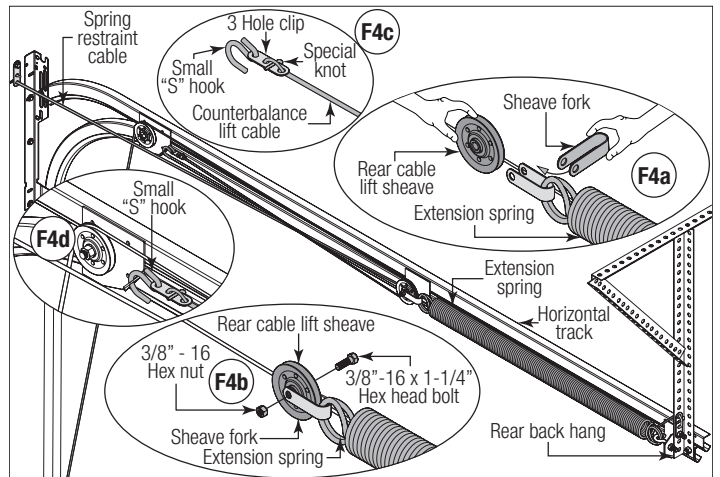

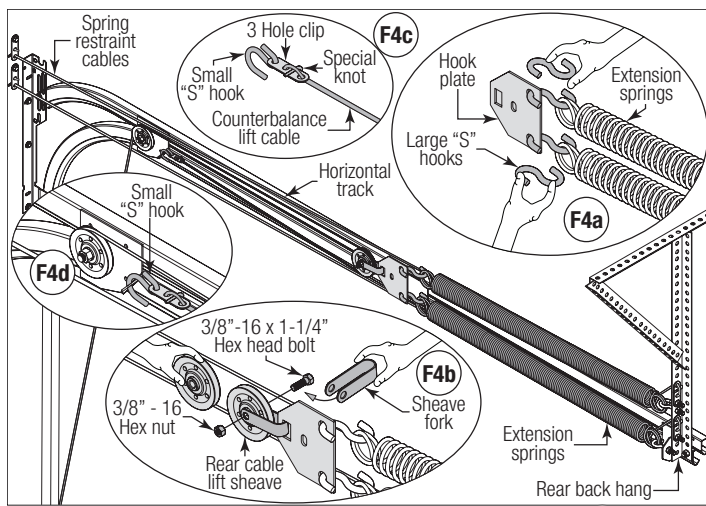

IMPORTANT: CLOSE "S" HOOKS AND EYE BOLTS WITH LOCKING PLIERS, TO PREVENT SPRINGS FROM COMING LOOSE.

IMPORTANT: WHENEVER ADJUSTING EXTENSION SPRING LENGTH FOR DOOR BALANCE, ALWAYS OPEN THE DOOR TO THE FULLY OPEN POSITION AND RETURN THE LOCKING PLIERS, AS SHOWN IN F3 TO THE HORIZONTAL TRACKS BELOW THE BOTTOM TRACK ROLLERS.

If door raises more than 2 ft. under spring tension alone, reduce spring tension. Adjust extension spring length by loosening the special knot on the 3 hole clip and lengthen the counterbalance lift cable between the 3 hole clip and the extension spring about 1/2". If door is hard to raise or drifts down on its own, add spring tension. Adjust extension spring length by loosening the special knot on the 3 hole clip and shortening the counterbalance lift cable between the 3 hole clip and the extension spring about 1/2". A poorly balanced door can cause garage door operator problems.

If the door still does not operate easily, raise the door into the open position, return the locking pliers, and recheck the following items:

- 1.) Is the door level?
- 2.) Are the flag angles level and plumb?
- 3.) Does the distance between the flag angles equal door width plus 3-3/8" to 3-1/2"?
- 4.) Do the counterbalance lift cables have equal tension? Adjust by re-tying the special knot, if necessary.
- 5.) Make sure door is not rubbing on jambs.

IMPORTANT: IF DOOR STILL DOES NOT BALANCE PROPERLY, THEN CONTACT A TRAINED DOOR SYSTEM TECHNICIAN.

F7

Attaching Weather Seal

Tools Required: Hammer, Step ladder, Safety glasses, Leather gloves

NOTE: Complete Step A10 now to permanently attach the weatherstrips.

WARNING
FAILURE TO CLOSE "S" HOOKS AND EYE BOLTS CAN RESULT IN SEVERE OR FATAL INJURY IF SPRINGS COME LOOSE.

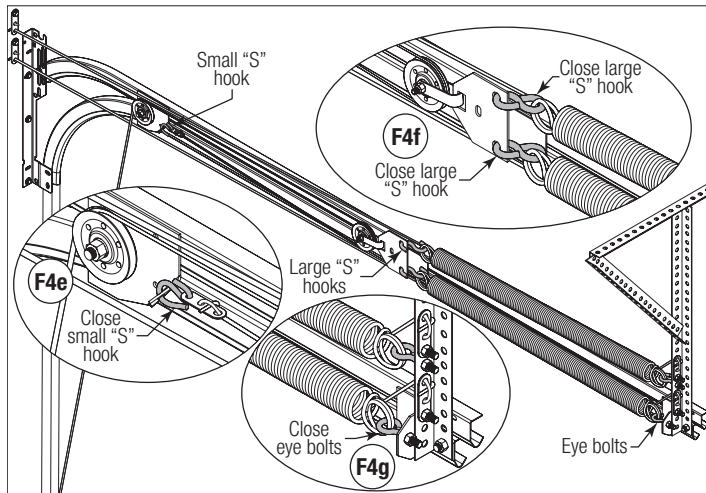

F5

Counterbalance Lift Cable Adjustments

Tools Required: 9/16" Wrench, Locking pliers, Tape measure, Level, Step ladder, Safety glasses, Leather gloves

Adjust counterbalance lift cables to create about 1" to 2" (25 mm to 50 mm) of pre-stretch on the extension spring, with the door in the fully opened position. Measure extension spring length (door open) and verify with the chart below. Spring length must be the same for both left hand and right hand extension springs to allow even door balance. Carefully remove the locking pliers from the horizontal track and lower the door into the closed position. Once the door is closed, measure the extension spring length for both sides. Using the chart, verify the spring length extended is correct for your door height.

Door Height	Spring Length (Door Open) (Does Not Include Pre-stretch)	Spring Length Extended (Door Closed) (Does Not Include Pre-stretch)
6' 0"	25" (635 mm)	61" (1549 mm)
6' 3"	25" (635 mm)	62-1/2" (1588 mm)
6' 6"	25" (635 mm)	64" (1626 mm)
7' 0"	25" (635 mm)	67" (1702 mm)
7' 6"	27" (686 mm)	72" (1829 mm)
7' 9"	27" (686 mm)	73-1/2" (1867 mm)
8' 0"	27" (686 mm)	75" (1905 mm)

F6

Balancing Door

Tools Required: Locking pliers, Tape measure, Step ladder, Safety glasses, Leather gloves

Cleaning Your Garage Door

IMPORTANT: DO NOT USE A PRESSURE WASHER ON YOUR GARAGE DOOR!

While factory-applied finishes on garage doors are durable, it is desirable to clean them on a routine basis. Some discoloration of the finish may occur when a door has been exposed to dirt-laden atmosphere for a period of time. Slight chalking may also occur as a result of direct exposure to sunlight. Cleaning the door will generally restore the appearance of the finish. To maintain an aesthetically pleasing finish of the garage door, a periodic washing of the garage door is recommended.

THE FOLLOWING CLEANING SOLUTION IS RECOMMENDED: A mild detergent solution consisting of one cup detergent (with less than 0.5% phosphate) dissolved into five gallons of warm water will aid in the removal of most dirt.

NOTE: The use of detergents containing greater than 0.5% phosphate is not recommended.

NOTE: Be sure to clean behind weatherstrips on both sides and top of door sections.

CAUTION

NEVER MIX CLEANSERS OR DETERGENTS WITH BLEACH.

NOTE: Do not use any window cleaning fluids, scouring compounds, gritty cloths or solvent-based cleaners of any kind.

To clean polycarbonate windows, see www.Wayne-Dalton.com.

Painting Your Garage Door

Refer to Insert **"Field Painting and Finishing Fiberglass or Steel Door Sections"**.

Maintaining The Finish On Your Garage Door

If the factory finish is beginning to fade, the door may require a field applied top clear coat. Depending on environment and usage, this may be necessary after 1 to 3 years of use. Refer to Instruction Insert **"Field Painting and Finishing Fiberglass Or Steel Door Sections"**.

Operation And Maintenance

OPERATING YOUR GARAGE DOOR: Before you begin, read all warning labels affixed to the door and the installation instructions and owner's manual. When correctly installed, your Wayne Dalton door will operate smoothly. Always operate your door with controlled movements. Do not slam your door or throw your door into the open position, this may cause damage to the door or its components. If your door has an electric opener, refer to the owner's manual to disconnect the opener before performing manual door operation below.

MANUAL DOOR OPERATION: For additional information on manual garage door operations go to www.dasma.com and reference TDS 165.

WARNING

DO NOT PLACE FINGERS OR HANDS INTO SECTION JOINTS WHEN OPENING AND/OR CLOSING A DOOR. ALWAYS USE LIFT HANDLES / SUITABLE GRIPPING POINTS WHEN OPERATING THE DOOR MANUALLY.

OPENING A DOOR: Make sure the lock(s) are in the unlocked position. Lift the door by using the lift handles / suitable gripping points only. Door should open with little resistance.

CLOSING A DOOR: From inside the garage, pull door downward using lift handles / gripping point only. If you are unable to reach the lift handles / suitable gripping points only, use pull down rope affixed to the side of door. Door should close completely with little resistance.

USING AN ELECTRIC OPERATOR:

IMPORTANT: PULL DOWN ROPES MUST BE REMOVED AND LOCKS MUST BE REMOVED OR MADE INOPERATIVE IN THE UNLOCKED POSITION.

When connecting a drawbar (trolley type) garage door operator to this door, a drawbar operator bracket must be securely attached to the top section of the door, along with any struts provided with the door. Always use the drawbar operator bracket supplied with the door. To avoid possible damage to your door, Wayne Dalton recommends reinforcing the top section with a strut (may or may not be supplied). The installation of the drawbar operator must be according to manufacturer's instructions and force settings must be adjusted properly. Refer to the owner's manual supplied with your drawbar operator for complete details on installation, operation, maintenance and testing of the operator.

MAINTAINING YOUR GARAGE DOOR: Before you begin, read all warning labels affixed to the door and the installation instructions and owner's manual. Perform routine maintenance steps once a month, and have the door professionally inspected once a year. Review your Installation Instructions and Owner's Manual for the garage door. These instructions are

available at no charge from Wayne Dalton, a division of Overhead Door Corporation, P.O. Box 67, Mt. Hope, OH., 44660, or at www.Wayne-Dalton.com. For additional information on garage door / operator maintenance go to www.dasma.com and reference TDS 151, 167 and 179.

MONTHLY INSPECTIONS:

1. VISUAL INSPECTION: Closely inspect jambs, header and mounting surface. Any material found not to be structurally sound must be replaced. It may be necessary to uninstall part or all of the door assembly in order to replace defective material. Refer to the supplemental instructions "Removing an Existing Door / Preparing the Opening" at www.Wayne-Dalton.com. Inspect the springs, counterbalance lift cables, track rollers, pulleys, rear back hangs and other door hardware for signs of worn or broken parts. Tighten any loose screws and/or bolts, except on bottom corner brackets or on the counterbalance assembly. Check exterior surface of the door sections for any minor cracks. Verify door has not shifted right or left in the opening. If you suspect problems, contact a trained door system technician.

WARNING

GARAGE DOOR SPRINGS, COUNTERBALANCE LIFT CABLES, BRACKETS, AND OTHER HARDWARE ATTACHED TO THE SPRINGS ARE UNDER EXTREME TENSION, AND IF HANDLED IMPROPERLY, CAN CAUSE SEVERE OR FATAL INJURY. ONLY A TRAINED DOOR SYSTEMS TECHNICIAN SHOULD ADJUST THEM, BY CAREFULLY FOLLOWING THE MANUFACTURER'S INSTRUCTIONS.

WARNING

NEVER REMOVE, ADJUST, OR LOOSEN THE BOLTS, SCREWS AND/OR LAG SCREWS ON THE COUNTERBALANCE (END BEARING BRACKETS, DRUMS OR SPRING SYSTEM) OR BOTTOM CORNER BRACKETS OF THE DOOR. THESE BRACKETS ARE CONNECTED TO THE SPRING(S) AND ARE UNDER EXTREME TENSION. TO AVOID POSSIBLE SEVERE OR FATAL INJURY, HAVE ANY SUCH WORK PERFORMED BY A TRAINED DOOR SYSTEMS TECHNICIAN USING PROPER TOOLS AND INSTRUCTIONS.

TORQUEMASTER® PLUS SPRINGS: Pawl knob(s) (located on the TorqueMaster® end brackets above the door) should be engaged to prevent the door from rapidly descending in case of spring failure or forceful manual operation.

EXTENSION SPRINGS: A restraining cable or other device should be installed on the extension spring (located above the horizontal tracks) to help contain the spring if it breaks.

2. DOOR BALANCE: Periodically test the balance of your door. If you have a garage door drawbar operator, use the release mechanism so you can operate the door by hand when doing this test. Start with the door in the fully closed position. Using handles or suitable gripping points, lift the door to check its balance. Adjust TorqueMaster® or Extension spring(s), if door lifts by itself (hard to pull down) or if door is difficult to lift (easy to pull down). DO NOT attempt to repair or adjust Torsion Springs yourself. To adjust TorqueMaster® or Extension spring(s), refer to your installation instructions and owner's manual. If in question about any of the procedures, do not perform the work. Instead, have it adjusted by a trained door systems technician.

3. LUBRICATION: The door should open and close smoothly. Ensure the door track rollers are rotating freely when opening and closing the door. If track rollers do not rotate freely, clean the door tracks, removing dirt and any foreign substances. Clean and lubricate (use a non-silicon based lubricant) graduated end hinges, center hinges, steel track rollers, bearings and torsion springs (torsion spring coil surfaces). DO NOT lubricate plastic idler bearings, nylon track rollers, door track. DO NOT oil a cylinder lock, if actuation is difficult use a graphite dust to lubricate.

CHECK FOR PRESENCE OF SAFETY LABELS:

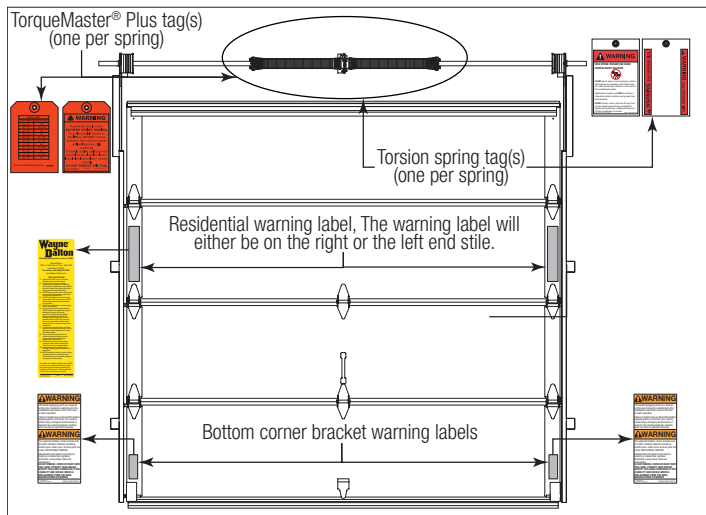

Limited Warranty

Models 8000, 8100, 8200, 8300 and 8500

Wayne Dalton, a division of Overhead Door Corporation ("Seller") warrants to the original purchaser of the Models 8000, 8100, 8200, 8300, the 8300 Sonoma Wood Grain and 8500 ("Product"), subject to all of the terms and conditions hereof, that the Product and all components thereof will be free from defects in materials and workmanship for the following period(s) of time, measured from the date of installation:

FOR DOOR MODELS 8000, 8100 AND 8200:

TEN (10) YEARS from the date of installation against:

- The Product becoming inoperable due to rust - through of the steel skin from the core of the Product section, due to cracking, splitting, or other deterioration of the steel skin, or due to structural failure caused by separation or degradation of the foam insulation.
Peeling of the original paint as a result of a defect in the original paint or in the application of the original paint coating.

TEN (10) YEARS on Product hardware and tracks (except springs).

ONE (1) YEAR on all other component and parts.

FOR DOOR MODELS 8300 AND 8500:

Limited Lifetime Warranty* on the Product sections against:

- The Product becoming inoperable due to rust-through of the steel skin from the core of the Product section, due to cracking, splitting, or other deterioration of the steel skin, or due to structural failure caused by separation or degradation of the foam insulation.
Peeling of the original paint as a result of a defect in the original paint or in the application of the original paint coating on standard paint colors (excludes Walnut or Golden Oak wood grain finish).
The Product hardware and tracks (except springs).

TWO (2) YEARS against peeling or fading of finish on Product sections with Walnut or Golden Oak wood grain finish.

ONE (1) YEAR on those component parts of the Product not covered by the preceding provisions of this Warranty.

*Limited Lifetime shall mean as long as the original purchaser owns the house in which the Product is originally installed.

Seller's obligation under this warranty is specifically limited to repairing or replacing, at its option, any part which is determined by Seller to be defective during the applicable warranty period. Any labor charges are excluded and will be the responsibility of the purchaser.

This warranty gives you specific legal rights, and you may also have other rights which vary from state to state. This warranty is made to the original purchaser of the Product only, and is not transferable or assignable. This warranty applies only to Product installed in a residential or other non-commercial application. It does not cover any Product installed in commercial or industrial building applications. This warranty does not apply to any unauthorized alteration or repair of the Product, or to any Product or component which has been damaged or deteriorated due to misuse, neglect, accident, failure to provide necessary maintenance, normal wear and tear, acts of God, or any other cause beyond the reasonable control of Seller or as a result of having been exposed to toxic or abrasive environments, including blowing sand, salt water, salt spray and toxic chemicals and fumes.

ALL EXPRESS AND IMPLIED WARRANTIES FOR THE PRODUCT, INCLUDING BUT NOT LIMITED TO ANY IMPLIED WARRANTIES OF MERCHANTABILITY AND FITNESS FOR A PARTICULAR PURPOSE, ARE LIMITED IN TIME TO THE APPLICABLE WARRANTY PERIOD REFLECTED ABOVE. NO WARRANTIES, WHETHER EXPRESS OR IMPLIED, WILL APPLY AFTER THE LIMITED WARRANTY PERIOD HAS EXPIRED. Some states do not allow limitations on how long an implied warranty lasts, so the above limitation may not apply to you.

IN NO EVENT SHALL SELLER BE RESPONSIBLE FOR, OR LIABLE TO ANYONE FOR, SPECIAL, INDIRECT, COLLATERAL, PUNITIVE, INCIDENTAL OR CONSEQUENTIAL DAMAGES, even if Seller has been advised of the possibility of such damages. Such excluded damages include, but are not limited to, loss of use, cost of any substitute product, or other similar indirect financial loss. Some states do not allow the exclusion or limitation of incidental or consequential damages, so the above limitation or exclusion may not apply to you.

Claims under this warranty must be made promptly after discovery, within the applicable warranty period, and in writing to the authorized distributor or installer whose name and address appear below. The purchaser must allow Seller a reasonable opportunity to inspect any Product claimed to be defective prior to removal or any alteration of its condition. Proof of the purchase and/or installation date, and identification as the original purchaser, may be required. There are no established informal dispute resolution procedures of the type described in the Magnuson-Moss Warranty Act.

- INSTALLING COMPANY:

- INSTALLING COMPANY'S ADDRESS:

Thank you for your purchase.

PLEASE DO NOT RETURN THIS PRODUCT TO THE STORE

If you need assistance, please call 1-866-569-3799 (press Option 1) and follow the prompts to contact a customer service representative. They will be happy to handle any questions that you may have.

After installation is complete, leave this quick start guide /owner's manual with the homeowner, or fasten it near garage door for easy reference.