

# Model Series 7100

TORSION

RESIDENTIAL AND LIGHT COMMERCIAL  
FRONT MOUNT LOW HEADROOM  
OUTSIDE HOOKUP

## QUICK START GUIDE

### **DEFINITION OF LIGHT COMMERCIAL:**

1. Door Heights less than or equal to 8'0" ( $\leq 8'0"$ ) are considered Residential Applications.
2. Door Heights greater than 8'0" ( $> 8'0"$ ) are considered Light Commercial Applications.

## **PLEASE DO NOT RETURN THIS PRODUCT TO THE STORE**

If you need assistance, please call 1-800-764-1457 (press Option 1) and follow the prompts to contact a customer service representative. They will be happy to handle any questions that you may have.

## Table Of Contents

<b>Pre-Installation</b>	<b>2</b>
Important Safety Instructions	2
Removing an Existing Door and Preparing the Opening	2
<b>Breakdown Of Parts</b>	<b>3</b>
<b>Door Installation Instructions</b>	<b>4</b>
<b>Counterbalance Installation Instructions</b>	<b>7</b>
<b>Maintenance</b>	<b>13</b>
Cleaning Your Garage Door	13
Painting Your Garage Door	13
Maintaining The Finish On Your Garage Door	13
Operation And Maintenance	13
<b>Warranty</b>	<b>14</b>

### **QUICK START GUIDE IMPORTANT NOTICES!**

This **Quick Start Guide is only meant to be used as an aid** and / or introduction to garage door installation, and does not replace the complete Installation Instructions and Owner's manual available on the web at [www.Wayne-Dalton.com](http://www.Wayne-Dalton.com). Wayne Dalton highly recommends that you read and fully understand the Installation Instructions and Owner's Manual before you attempt this installation.

To avoid possible injury, read and fully understand the enclosed instructions carefully before installing and operating the garage door. Pay close attention to all warnings and notes. After installation is complete, fasten this manual near garage door for easy reference.

The complete Installation Instructions and Owner's Manual are available at no charge from:

- Your local Wayne Dalton Sales Center, or
- Online at [www.Wayne-Dalton.com](http://www.Wayne-Dalton.com), or
- By mailing to: Wayne Dalton, a division of Overhead Door Corporation, P.O. Box 67, Mt. Hope, OH., 44660

## Important Safety Instructions

**DEFINITION OF KEY WORDS USED IN THIS MANUAL:**

### **WARNING**

INDICATES A POTENTIALLY HAZARDOUS SITUATION WHICH; IF NOT AVOIDED, COULD RESULT IN SEVERE OR FATAL INJURY.

### **CAUTION**

PROPERTY DAMAGE OR INJURY CAN RESULT FROM FAILURE TO FOLLOW INSTRUCTIONS.

**IMPORTANT:** REQUIRED STEP FOR SAFE AND PROPER DOOR OPERATION.

**NOTE:** Information assuring proper installation of the door.

**READ THESE INSTRUCTIONS CAREFULLY BEFORE ATTEMPTING INSTALLATION. IF IN QUESTION ABOUT ANY OF THE PROCEDURES, DO NOT PERFORM THE WORK. INSTEAD, HAVE A TRAINED DOOR SYSTEMS TECHNICIAN DO THE INSTALLATION OR REPAIRS.**

1. READ AND FOLLOW ALL INSTALLATION INSTRUCTIONS.
2. Wear protective gloves during installation to avoid possible cuts from sharp metal edges.
3. It is always recommended to wear eye protection when using tools, otherwise eye injury could result.
4. Avoid installing your new door on windy days. Door could fall during the installation causing severe or fatal injury.
5. Doors 12'-0" wide and over should be installed by two persons, to avoid possible injury.
6. Operate door only when it is properly adjusted and free from obstructions.
7. If a door becomes hard to operate, inoperative or is damaged, immediately have necessary adjustments and/ or repairs made by a trained door system technician using proper tools and instructions.
8. DO NOT stand or walk under a moving door, or permit anybody to stand or walk under an electrically operated door.
9. DO NOT place fingers or hands into open section joints when closing a door. Use lift handles/ gripping points when operating door manually.
10. DO NOT permit children to operate garage door or door controls. Severe or fatal injury could result should the child become entrapped between the door and the floor.
11. Due to constant extreme spring tension, do not attempt any adjustment, repair or alteration to any part of the door, especially to springs, spring brackets, bottom corner brackets, fasteners, counterbalance lift cables or supports. To avoid possible severe or fatal injury, have any such work performed by a trained door systems technician using proper tools and instructions.
12. On electrically operated doors, pull down ropes must be removed and locks must be removed or made inoperative in the open (unlocked) position.
13. Top section of door may need to be reinforced when attaching an electric opener. Check door and/ or opener manufacturer's instructions.
14. Visually inspect door and hardware monthly for worn and or broken parts. Check to ensure door operates freely.
15. Test electric opener's safety features monthly, following opener manufacturer's instructions.
16. NEVER hang tools, bicycles, hoses, clothing or anything else from horizontal tracks. Track systems are not intended or designed to support extra weight.
17. This door may not meet the building code wind load requirements in your area. For your safety, you will need to check with your local building official for wind load code requirements and building permit information.
18. For windloaded doors, the wind performance is achieved via the entire door system and component substitution is not authorized without express permission by Wayne Dalton.

**NOTE:** It is recommended that 5/16" lag screws are pilot drilled using a 3/16" drill bit, prior to fastening.



### **CAUTION**

IF ANY PART OF THE DOOR IS TO BE INSTALLED ONTO PRESERVATIVE-TREATED WOOD, PTFE-COATED OR STAINLESS STEEL FASTENERS MUST BE OBTAINED AND USED. REPLACEMENT FASTENERS MUST BE OF AT LEAST EQUAL STRENGTH AND SIZE AS ORIGINAL FASTENERS. IF THE ORIGINAL FASTENER WAS RED-HEAD, THE REPLACEMENT FASTENER MUST BE RED-HEAD ALSO. CONTACT WAYNE DALTON FOR FASTENER STRENGTH VALUES IF NEEDED.

### **WARNING**

**IMPACT GUNS ARE NOT RECOMMENDED. WHEN INSTALLING 5/16" LAG SCREWS USING AN ELECTRIC DRILL/ DRIVER, THE DRILL/ DRIVERS CLUTCH MUST BE SET TO DELIVER NO MORE THAN 200 IN-LBS OF TORQUE. FASTENER FAILURE COULD OCCUR AT HIGHER SETTINGS.**

**IMPORTANT:** RIGHT AND LEFT HAND IS DETERMINED INSIDE THE BUILDING LOOKING OUT.

Potential Hazard	Effect	Prevention
 <p>Moving door</p>	<p><b>WARNING</b></p> <p>Could result in Death or Serious Injury</p>	<p>Keep people clear of opening while Door is moving.</p> <p>Do <b>NOT</b> allow children to play with the Door Opener.</p> <p>Do <b>NOT</b> operate a Door that jams or one that has a broken spring.</p>
 <p>High tension spring</p>	<p><b>WARNING</b></p> <p>Could result in Death or Serious Injury</p>	<p>Do <b>NOT</b> try to remove, install, repair or adjust springs or anything to which door spring parts are fastened, such as, wood blocks, steel brackets, cables or other like items.</p> <p>Installations, repairs and adjustments must be done by a trained door system technician using proper tools and instructions.</p>

## Removing an Existing Door and Preparing the Opening

**IMPORTANT:** COUNTERBALANCE SPRING TENSION MUST ALWAYS BE RELEASED BEFORE ANY ATTEMPT IS MADE TO START REMOVING AN EXISTING DOOR.

### **WARNING**

**A POWERFUL SPRING RELEASING ITS ENERGY SUDDENLY CAN CAUSE SEVERE OR FATAL INJURY. TO AVOID INJURY, HAVE A TRAINED DOOR SYSTEMS TECHNICIAN, USING PROPER TOOLS AND INSTRUCTIONS, RELEASE THE SPRING TENSION.**

To avoid possible injury and to insure proper installation, it's highly recommended that you read and fully understand the complete instructions on removing an Existing Door & Preparing the Opening. These are available for download at [www.Wayne-Dalton.com](http://www.Wayne-Dalton.com) or at your local Wayne Dalton Sales Center.

**WEATHERSTRIPS (MAY NOT BE INCLUDED):**

Depending on the size of your door, you may have to cut or trim the weatherstrips (if necessary) to properly fit into the header and jambs.

**NOTE:** If nailing product at 40°F or below, pre-drilling is required.

**NOTE:** Do not permanently attach weatherstrips to the header and jambs at this time.

For the header, align the weatherstrip 1/8" to 1/4" inside the header edge, and temporarily secure it to the header with equally spaced nails. Starting at either side of the jamb, fit the weatherstrip up tight against the temporarily attached weatherstrip in the header and 1/8" to 1/4" inside the jamb edge. Temporarily secure the weatherstrip with equally spaced nails. Repeat for other side. This will keep the bottom section from falling out of the opening during installation. Equally space nails approximately 12" to 18" apart.

# BREAKDOWN OF PARTS

**NOTE:** The illustrations shown on this page are general representations of the door parts. Each specific door models may have unique variations.

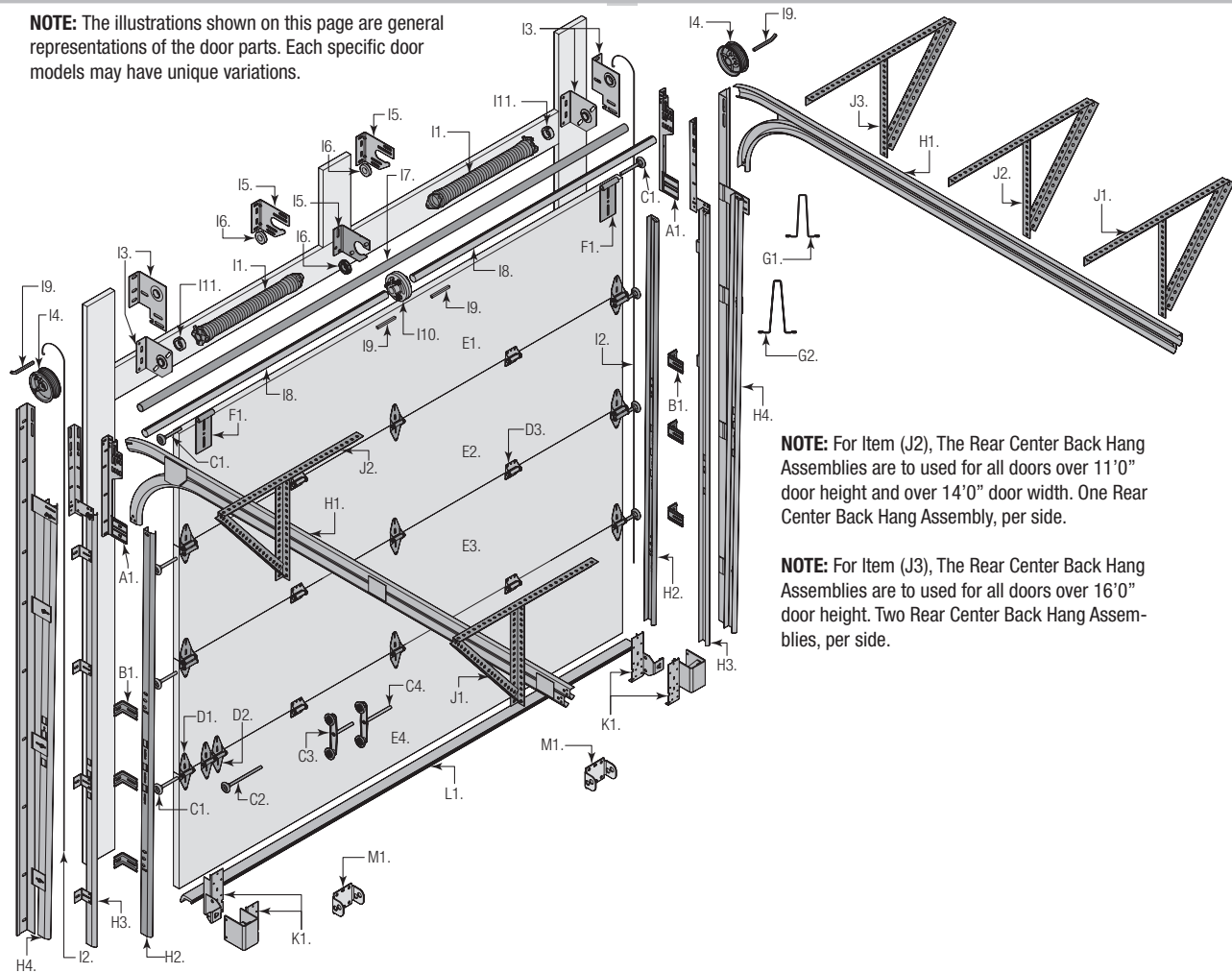

**NOTE:** For Item (J2), The Rear Center Back Hang Assemblies are to be used for all doors over 11'0" door height and over 14'0" door width. One Rear Center Back Hang Assembly, per side.

**NOTE:** For Item (J3), The Rear Center Back Hang Assemblies are to be used for all doors over 16'0" door height. Two Rear Center Back Hang Assemblies, per side.

## A. FLAG ANGLES (AS REQUIRED):

A1. Fully Adjustable (F.A.) Flag Angles

## B. JAMB BRACKETS (AS REQUIRED):

B1. Fully Adjustable (F.A.) Jamb Brackets

## C. TRACK ROLLERS (AS REQUIRED):

- C1. Short Stem Track Rollers
- C2. Long Stem Track Rollers
- C3. Short Stem Tandem Track Rollers
- C4. Long Stem Tandem Track Rollers

## D. GRADUATED END HINGES:

- D1. Single Graduated End Hinges (S.E.H.), Industry Standard
- D2. Double Graduated End Hinges (D.E.H.), Industry Standard
- D3. Half Center Hinges (As required)

## E. STACKED SECTIONS:

- E1. Top Section
- E2. Intermediate(s) Section
- E3. Bottom Section

## F. TOP FIXTURES (AS REQUIRED):

F1. Top Fixtures

## G. STRUT(S) (AS REQUIRED):

G1. Strut (2" U-shaped) / G2. Strut (3" U-shaped)

## H. TRACKS (AS REQUIRED):

- H1. Left Hand and Right Hand Horizontal Track Assemblies
- H2. Left Hand and Right Hand Vertical Tracks

H3. Left Hand and Right Hand Riveted Vertical Track Assemblies

H4. Left Hand and Right Hand Angle Mount Vertical Track Assemblies

## I. TORSION SPRING ASSEMBLY (AS REQUIRED):

- I1. Left Hand and Right Hand Torsion Springs (As Required)
- I2. Counterbalance Lift Cables
- I3. Left Hand and Right Hand Bearing Brackets (As Required)
- I4. Left Hand and Right Hand Cable Drums
- I5. Center Bracket (As Required)
- I6. Center Bracket Bearing (As Required)
- I7. Torsion Shaft / Torsion Keyed Shaft (As Required)
- I8. Torsion Keyed Shafts (As Required)
- I9. Keys (As Required)
- I10. Center Coupler Assembly (As Required)
- I11. Set Collars (As Required)

## J. REAR BACK HANGS:

- J1. Left Hand And Right Hand Rear Back Hang Assemblies
- J2. Left and Right Hand Rear Center Back Hang Assemblies (As Required)
- J3. Left and Right Hand Rear Center Back Hang Assemblies (As Required)

## K. BOTTOM CORNER BRACKETS (AS REQUIRED):

K1. Left Hand and Right Hand Bottom Corner Brackets

## L. BOTTOM WEATHER SEAL (AS REQUIRED):

L1. Bottom Weather Seal (Door Width), (Nails Not Supplied)

## M. TRACK ROLLER CARRIERS (AS REQUIRED):

M1. Track Roller Carriers

# DOOR INSTALLATION INSTRUCTIONS

Before installing your door, be certain that you have read and followed all of the instructions covered in the pre-installation section of this manual. Failure to do so may result in an improperly installed door.

**NOTE:** Reference TDS 160 for general garage door terminology at [www.dasma.com](http://www.dasma.com).

**IMPORTANT:** WOOD DOORS MUST BE COMPLETELY FINISHED (3 TOTAL COATS, INCLUDING PRIMER COAT) PRIOR TO INSTALLATION, TO ENSURE THAT THE INTERIOR AND EXTERIOR SURFACES, AS WELL AS ALL EDGES OF THE DOORS ARE PROPERLY PROTECTED AGAINST MOISTURE OR OTHER CONTAMINANTS. WOOD DOORS, IN A NON-FINISHED CONDITION, MUST BE TRANSPORTED AND STORED SO THE WOOD SURFACES ARE NOT EXPOSED TO MOISTURE OR OTHER CONTAMINANTS. IMPROPER TRANSPORTATION, STORAGE OR DELAYS IN FINISHING, THAT ALLOWS EXPOSURE OF THE WOOD DOOR SURFACES TO MOISTURE OR OTHER CONTAMINANTS WILL RESULT IN THE WARRANTY BEING VOIDED.

## 1 Attaching Flag Angles and Jamb Brackets To Vertical Tracks

**NOTE:** If you have Riveted Track or Angle Mount Track, skip this step.

Hand tighten the left hand flag angle to the left hand vertical track using (2) 1/4" - 20 x 9/16" track bolts and (2) 1/4" - 20 flange hex nuts.

**NOTE:** The bottom jamb bracket is always the shortest bracket, while the center jamb bracket is the next tallest. If three jamb brackets per side are included with your door, you will have received a top jamb bracket, which is the tallest.

To attach the bottom jamb bracket, locate lower hole of the hole/ slot pattern of the 1st hole set on the vertical track. Align the slot in the jamb bracket with the lower hole of the hole/ slot pattern. Hand tighten jamb bracket using (1) 1/4" - 20 x 9/16" track bolt and (1) 1/4" - 20 flange hex nut.

Place the center jamb bracket over the lower hole of the hole/ slot pattern that is centered between the bottom jamb bracket and flag angle of the 2nd hole set. Hand tighten jamb bracket using (1) 1/4" - 20 x 9/16" track bolt and (1) 1/4" - 20 flange hex nut.

If a top jamb bracket was included, hand tighten it to vertical track using the lower hole of the hole/ slot pattern in the 3rd hole set and (1) 1/4" - 20 x 9/16" track bolt and (1) 1/4" - 20 flange hex nut.

Repeat the same process for right hand side.

## 2 Attaching Bottom Weather Seal

**NOTE:** Reference Package Contents or Breakdown Of Parts, to determine if a bottom weather seal was supplied. If a bottom weather seal was supplied, complete this step.

**NOTE:** Refer to door section identification, located in the pre-installation section of this manual to determine what size section you need to use as your bottom (first) section. Measure your section to make sure it is the correct height as indicated on the chart.

Place the bottom section face down on a couple of sawhorses or flat clean/ smooth surface. Align the bottom weather seal with the flap pointing towards the outside surface of the bottom section. Starting at one end of the door, measure inward 1" and attach the bottom weather seal to the bottom of the bottom section with 3/4" long galvanized roofing nails (not supplied). Now stretch the bottom weather seal slightly and nail the rest of the bottom weather seal to the bottom of the bottom section every 6". Once the bottom weather seal is fastened cut off any extra material so that the bottom weather seal is even with both ends of the bottom section.

**NOTE:** Verify bottom weather seal is aligned with bottom section. If there is more than 1/2" excess weather seal on either side, trim weather seal even with bottom section.

## 3 Attaching Bottom Corner Brackets

**NOTE:** Refer to door section identification, located in the pre-installation section of this manual or refer to Breakdown of Parts.

With the bottom section facing down from the previous step, uncoil the counterbalance lift cables.

**NOTE:** Refer to Package Contents / Breakdown of Parts, to determine which bottom corner brackets you have.

Secure the cable loop to the clevis pin and bottom corner bracket using a flat washer and a cotter pin. Repeat for other bottom corner bracket.

### WARNING

**ENSURE TIGHT FIT OF CABLE LOOP OVER PIN TO PREVENT COUNTERBALANCE LIFT CABLE FROM COMING OFF THE PIN, WHICH COULD ALLOW THE DOOR TO FALL AND RESULT IN SEVERE OR FATAL INJURY.**

Locate the left hand bottom corner bracket. Align the bottom corner bracket horizontally with the bottom edge of the bottom section and also align the bottom corner bracket vertically with the left bottom edge of the bottom section. Mark and pre-drill 9/32" diameter holes through the bottom section. Attach the bottom corner bracket to the bottom section using (3) 1/4" - 20 x 2-1/4" carriage bolts and (3) 1/4" - 20 RED HEAD flange hex nuts. Repeat the same process for the right hand side.

**IMPORTANT:** THE CARRIAGE BOLTS AND THE 1/4" - 20 RED HEAD FLANGE HEX NUTS MUST BE INSTALLED ON THE BOTTOM CORNER BRACKETS, AS SHOWN.

## 4 Attaching Track Roller Carrier's

**NOTE:** If you don't have track roller carriers, then skip this step. Refer to Package Contents / Breakdown of Parts, to determine if a track roller carrier was supplied with your door.

Starting on left hand side of the bottom section, position the track roller carrier with the stamp "STD" facing UP to the bottom corner bracket and aligning the four holes of the track roller carrier with the four holes in the bottom corner bracket. Secure the track roller carrier to the bottom corner bracket with (4) 1/4" - 14 x 1" lag screws.

**NOTE:** Prior to fastening the track roller carrier to the bottom section, pilot drill using a 1/8" drill bit.

**IMPORTANT:** BE EXTREMELY CAREFUL NOT TO DRILL THRU THE SECTION. ONLY DRILL 1" DEEP.

Insert a short stem track roller and spacer into the bottom corner bracket. Repeat the same process for the right hand side.

**NOTE:** The track roller carrier's inner holes are used on doors with 2" track applications; the outer holes are used on doors with 3" track applications.

## 5 Attaching Hinges and Strut To Bottom Section

Lay a **SHORT STRUT** onto the bottom rail of the bottom section. Position the bottom of the strut 3/4" up from the bottom edge of the bottom section. Center the short strut from side to side on the section surface. Drill pilot holes, 1" deep into the bottom section using a 1/8" drill bit.

**IMPORTANT:** BE EXTREMELY CAREFUL NOT TO DRILL THRU THE SECTION. ONLY DRILL 1" DEEP.

Attach the strut using (1) 1/4" - 14 x 1" lag screw at each pre-drilled hole.

**NOTE:** Refer to the Graduated End Hinge Schedule below, to determine the appropriate hinges for your bottom section.

Graduated End Hinge Schedule		
Door Height	Section Type	Graduated End Hinge Number
3 Section High Door	Bottom	#2
4 Section High Door		#1

**NOTE:** Center hinge(s) use #1 graduated end hinges at each pre-drilled or vertical stile location. The pre-drilled locations are located at the top rails on the inside of the section surface.

**NOTE:** Measure the height of the long strut(s) to determine if you have 2" or 3".

**NOTE:** Some struts also may or may not have holes in them. If they don't, then prior to installing the strut and hinge to the section surface, you may have to drill a 3/16" hole for the appropriate fastener on one or both sides of the strut legs.

Using the appropriate graduated end hinges for the ends and depending on the width of your door, enough center hinge(s) for each pre-drilled hole location(s). Starting at the upper left hand corner of the bottom section. Position the lower hinge leaf of the appropriate graduated end hinge onto the upper corner of the bottom section. Align the slots of the lower hinge leaf with the pre-drilled holes in the bottom section.

**NOTE:** If you have strut clips, ensure the strut clip is positioned on the hinge, as shown.

### **FOR GRADUATED END HINGES:**

**IF YOU HAVE 2" LONG STRUTS:** Lay the leg of the long strut over the bottom hole of the lower hinge leaf and the bottom section. Center the long strut from side to side. Attach the upper slot of the graduated end hinge to the bottom section using (1) 1/4" - 20 x 2-1/4" carriage bolt and (1) 1/4" - 20 flange hex nut. Next attach the bottom hole of the graduated end hinge to the upper leg of the strut to the bottom section using (1) 1/4" - 20 x 2-1/4" carriage bolt and (1) 1/4" - 20 flange hex nut. Next secure the bottom leg of the strut to the bottom section using (1) 1/4" - 20 x 2-1/4" carriage bolt and (1) 1/4" - 20 flange hex nut. Repeat for other side.

**IF YOU HAVE 3" LONG STRUTS:** Lay a long strut over the lower hinge leaf and over the top rail of the bottom section. Center the long strut from side to side. Attach the upper slot of the graduated end hinge, (1) strut clip to the upper leg of the strut to the bottom section using (1) 1/4" - 20 x 2-1/4" carriage bolt and (1) 1/4" - 20 flange hex nut. Next secure the bottom leg of the strut with the hole of the graduated end hinge to the bottom section using (1) 1/4" - 20 x 2-1/4" carriage bolt and (1) 1/4" - 20 flange hex nut. Repeat for other side.

**IF YOU HAVE DOUBLE GRADUATED END HINGES:** Position the second graduated end hinge next to the first (single) graduated end hinge. Using the second graduated end hinge as a template, drill pilot holes, 1" deep into the bottom section using a 1/8" drill bit.

**IMPORTANT:** BE EXTREMELY CAREFUL NOT TO DRILL THRU THE SECTION. ONLY DRILL 1" DEEP.

Secure the strut and the graduated end hinge to the bottom section using (2) 1/4" - 14 x 1" lag screws. Repeat for other side.

**FOR CENTER HINGES:** Align the slots of the lower hinge leaf with the pre-drilled holes at each center stile, located at the top rail of the bottom section. Using the center hinge as a template, drill pilot holes, 1" deep into the bottom section with a 1/8" drill bit (if needed).

**IMPORTANT:** BE EXTREMELY CAREFUL NOT TO DRILL THRU THE SECTION. ONLY DRILL 1" DEEP.

**IF YOU HAVE 2" LONG STRUTS:** Attach the upper slot of the center hinge using a 1/4" - 14 x 1" lag screw. Secure the leg of the strut to the hole of the center hinge using a 1/4" - 14 x 1" lag screw. Secure the other leg of the strut to the section using a 1/4" - 14 x 1" lag screw. Repeat for other center hinge(s).

**IF YOU HAVE 3" LONG STRUTS:** Attach the upper leg of the strut to the upper slot of the center hinge using (1) strut clip and a 1/4" - 14 x 1" lag screw. Secure the lower leg of the strut to the hole of the center hinge using a 1/4" - 14 x 1" lag screw. Repeat for other center hinge(s).

**NOTE:** If you don't have half center hinges, then skip this part of the step. Refer to Package Contents / Breakdown Of Parts, to determine if you have half center hinges.

Using a tape measure, position the half center hinges equally spaced in between the center hinges and the graduated end hinges. Position the holes of the lower hinge leaf at the top rail of the bottom section. Using the half center hinge as a template, drill pilot holes, 1" deep into the bottom section with a 1/8" drill bit (if needed).

**IMPORTANT:** BE EXTREMELY CAREFUL NOT TO DRILL THRU THE SECTION. ONLY DRILL 1" DEEP.

Attach the lower hinge leaf of the center hinge to the bottom section using (2) 1/4" - 14 x 1" lag screws. Repeat for other half center hinge(s).

If you have single graduated end hinges, insert a short stem track roller / short stem tandem track roller (if included) into the hinge tube on each side.

If you have double graduated end hinges, insert a long stem track roller / short stem tandem track roller (if included) into the hinge tubes on each side.

**IMPORTANT:** WHEN PLACING TRACK ROLLERS / TANDEM TRACK ROLLER (IF INCLUDED) INTO GRADUATED END HINGES NUMBER 2 AND HIGHER, THE TRACK ROLLER / TANDEM TRACK ROLLER (IF INCLUDED) GOES INTO TUBE FURTHEST AWAY FROM SECTION.

long strut over the lower hinge leaf and over the top rail of the Intermediate section. Center the long strut from side to side.

**FOR GRADUATED END HINGES:**

**IF YOU HAVE 2" LONG STRUTS:** Lay the leg of the long strut over the bottom hole of the lower hinge leaf and the Intermediate section. Center the long strut from side to side. Attach the upper slot of the graduated end hinge to the Intermediate section using (1) 1/4" - 20 x 2-1/4" carriage bolt and (1) 1/4" - 20 flange hex nut. Next attach the bottom hole of the graduated end hinge to the upper leg of the strut to the Intermediate section using (1) 1/4" - 20 x 2-1/4" carriage bolt and (1) 1/4" - 20 flange hex nut. Next secure the bottom leg of the strut to the Intermediate section using (1) 1/4" - 20 x 2-1/4" carriage bolt and (1) 1/4" - 20 flange hex nut. Repeat for other side.

**IF YOU HAVE 3" LONG STRUTS:** Lay a long strut over the lower hinge leaf and over the top rail of the Intermediate section. Center the long strut from side to side. Attach the upper slot of the graduated end hinge, (1) strut clip to the upper leg of the strut to the Intermediate section using (1) 1/4" - 20 x 2-1/4" carriage bolt and (1) 1/4" - 20 flange hex nut. Next secure the bottom leg of the strut with the hole of the graduated end hinge to the Intermediate section using (1) 1/4" - 20 x 2-1/4" carriage bolt and (1) 1/4" - 20 flange hex nut. Repeat for other side.

**IF YOU HAVE DOUBLE GRADUATED END HINGES:** Position the second graduated end hinge next to the first (single) graduated end hinge. Using the second graduated end hinge as a template, drill pilot holes, 1" deep into the bottom section using a 1/8" drill bit.

**IMPORTANT:** BE EXTREMELY CAREFUL NOT TO DRILL THRU THE SECTION. ONLY DRILL 1" DEEP.

Secure the strut and the graduated end hinge to the Intermediate section using (2) 1/4" - 14 x 1" lag screws. Repeat for other side.

**FOR CENTER HINGES:** Align the slots of the lower hinge leaf with the pre-drilled holes at each center stile, located at the top rail of the Intermediate section. Using the center hinge as a template, drill pilot holes, 1" deep into the Intermediate section with a 1/8" drill bit (if needed).

**IMPORTANT:** BE EXTREMELY CAREFUL NOT TO DRILL THRU THE SECTION. ONLY DRILL 1" DEEP.

**IF YOU HAVE 2" LONG STRUTS:** Attach the upper slot of the center hinge using a 1/4" - 14 x 1" lag screw. Secure the leg of the strut to the hole of the center hinge using a 1/4" - 14 x 1" lag screw. Secure the other leg of the strut to the section using a 1/4" - 14 x 1" lag screw. Repeat for other center hinge(s).

**IF YOU HAVE 3" LONG STRUTS:** Attach the upper leg of the strut to the upper slot of the center hinge using (1) strut clip and a 1/4" - 14 x 1" lag screw. Secure the lower leg of the strut to the hole of the center hinge using a 1/4" - 14 x 1" lag screw. Repeat for other center hinge(s).

**NOTE:** If you don't have half center hinges, then skip this part of the step. Refer to Package Contents / Breakdown Of Parts, to determine if you have half center hinges.

Using a tape measure, position the half center hinges equally spaced in between the center hinges and the graduated end hinges. Position the holes of the lower hinge leaf at the top rail of the Intermediate section. Using the half center hinge as a template, drill pilot holes, 1" deep into the Intermediate section with a 1/8" drill bit (if needed).

**IMPORTANT:** BE EXTREMELY CAREFUL NOT TO DRILL THRU THE SECTION. ONLY DRILL 1" DEEP.

Attach the lower hinge leaf of the center hinge to the Intermediate section using (2) 1/4" - 14 x 1" lag screws. Repeat for other half center hinge(s).

If you have single graduated end hinges, insert a short stem track roller / short stem tandem track roller (if included) into the hinge tube on each side.

If you have double graduated end hinges, insert a long stem track roller / short stem tandem track roller (if included) into the hinge tubes on each side.

**IMPORTANT:** WHEN PLACING TRACK ROLLERS / TANDEM TRACK ROLLER (IF INCLUDED) INTO GRADUATED END HINGES NUMBER 2 AND HIGHER, THE TRACK ROLLER / TANDEM TRACK ROLLER (IF INCLUDED) GOES INTO TUBE FURTHEST AWAY FROM SECTION.

## 6

### Attaching Hinges and Strut To Intermediate Section(s)

**NOTE:** Refer to door section identification, located in the pre-installation section of this manual to determine what size section you need to use as your intermediate I (second) and if applicable intermediate II (third) section. Measure your section to make sure it is the correct height as indicated on the chart.

**NOTE:** Refer to the Graduated End Hinge Schedule below, to determine the appropriate hinges for your bottom section.

Graduated End Hinge Schedule		
Door Height	Section Type	Graduated End Hinge Number
3 Section High Door	Intermediate I	#4
4 Section High Door	Intermediate II	#3
	Intermediate I	#2

**NOTE:** Refer to the Strutting Schedules below, to determine the appropriate strutting for your Intermediate(s) section.

3 Section High Strutting Schedule		
Section Type	Type Of Strut	Location On Section
Intermediate I	(1) Long	Top Of Section
	N/A	Bottom Of Section

4 Section High Strutting Schedule		
Section Type	Type Of Strut	Location On Section
Intermediate II	N/A	Top Of Section
	N/A	Bottom Of Section
Intermediate I	(1) Long	Top Of Section
	N/A	Bottom Of Section

**NOTE:** Center hinge(s) use #1 graduated end hinges at each pre-drilled or vertical stile location. The pre-drilled locations are located at the top rails on the inside of the section surface.

**NOTE:** Some struts also may or may not have holes in them. If they don't, then prior to installing the strut and hinge to the section surface, you may have to drill a 3/16" hole for the appropriate fastener on one or both sides of the strut legs.

Place the Intermediate I section face down on a couple of sawhorses or flat clean/ smooth surface. Using the appropriate graduated end hinges for the ends and depending on the width of your door, enough center hinge(s) for each pre-drilled hole location(s). Starting at the upper left hand corner of the Intermediate section. Position the lower hinge leaf of the appropriate graduated end hinge onto the upper corner of the Intermediate section. Align the slots of the lower hinge leaf with the pre-drilled holes in the Intermediate section. Next, lay a

## 7

### Attaching Top Fixtures And Strut To Top Section

**NOTE:** Refer to door section identification, located in the pre-installation section of this manual to determine what size section you need to use as your top section. Measure your section to make sure it is the correct height as indicated on the chart.

Place the top section face down on a couple of sawhorses or flat clean/ smooth surface. Lay a **SHORT STRUT** onto the top rail of the top section. Position the top of the strut 3/4" downward from the top edge of the top section. Center the short strut from side to side on the section surface. Drill pilot holes, 1" deep into the top section using a 1/8" drill bit.

**IMPORTANT:** BE EXTREMELY CAREFUL NOT TO DRILL THRU THE SECTION. ONLY DRILL 1" DEEP.

Attach the strut using (1) 1/4" - 14 x 1" lag screw at each pre-drilled hole.

**NOTE:** If your door came with two top fixtures, then one top fixture and a short stem track roller are required for each side.

**NOTE:** If your door came with four top fixtures, then two top fixtures and a long stem track roller are required for each side.

Starting on the left hand side, align the edge of the top fixture parallel to the top section edge. Using the top fixture base as a template, mark and pre-drill (2) 9/32" diameter holes through the top section. Loosely attach the top fixture base to the top section using (2) 1/4" - 20 x 2-1/4" carriage bolts and (2) 1/4" - 20 flange hex nuts. Repeat the same process for

the right hand side.

**IF YOU HAVE FOUR TOP FIXTURE ASSEMBLIES:** Position the second top fixture assembly next to the first installed top fixture assembly. Using the top fixture base as a template, drill pilot holes, 1" deep into the top section with a 1/8" drill bit (if needed).

**IMPORTANT:** BE EXTREMELY CAREFUL NOT TO DRILL THRU THE SECTION. ONLY DRILL 1" DEEP.

Loosely attach the top fixture base to the top section using (2) 1/4" - 14 x 1" lag screws. Repeat the same process for the right hand side.

## 8 Positioning Bottom Section

Center the bottom section in the door opening. Level the section using wooden shims (if necessary) under the bottom section. When the bottom section is leveled, temporarily hold it in place by driving a nail into the jamb and bending it over the edge of the bottom section on both sides.

## 9 Attaching Vertical Tracks To Jamb

**NOTE:** Depending on your door, you may have Fully Adjustable Flag Angles, Riveted Vertical Track Assemblies or you may have Angle Mount Vertical Track Assemblies. Refer to Package Contents / Breakdown of Parts, to determine which Flag Angles / Vertical Track Assemblies you have.

**IMPORTANT:** IF YOUR DOOR IS TO BE INSTALLED PRIOR TO A FINISHING CONSTRUCTION OF THE BUILDING'S FLOOR, THE VERTICAL TRACKS AND THE DOOR BOTTOM SECTION ASSEMBLY SHOULD BE INSTALLED SUCH THAT WHEN THE FLOOR IS CONSTRUCTED, NO DOOR OR TRACK PARTS ARE TRAPPED IN THE FLOOR CONSTRUCTION.

**IMPORTANT:** THE TOPS OF THE VERTICAL TRACKS MUST BE LEVEL FROM SIDE TO SIDE. IF THE BOTTOM SECTION WAS SHIMMED TO LEVEL IT, THE VERTICAL TRACK ON THE SHIMMED SIDE MUST BE RAISED THE HEIGHT OF THE SHIM.

**NOTE:** Make sure the counterbalance lift cable is located between the track rollers and the door jamb.

Starting on the left hand side of the bottom section, remove the nail. Position the left hand vertical track assembly over the track rollers of the bottom section and install, as shown. Drill 3/16" pilot holes into the door jamb for the lag screws.

**FOR FULLY ADJUSTABLE FLAG ANGLES:** Loosely fasten jamb brackets and flag angle to the jamb using 5/16" x 1-5/8" lag screws. Tighten lag screws, securing the bottom jamb bracket to jamb, maintain 3/8" to 5/8" spacing, between the bottom section and vertical track. Hang counterbalance lift cable over flag angle. Repeat same process for other side.

**FOR RIVETED VERTICAL TRACK ASSEMBLY:** Loosely fasten jamb brackets and flag angle to the jamb using 5/16" x 1-5/8" lag screws. Tighten lag screws, securing the bottom jamb bracket to jamb, maintain 3/8" to 5/8" spacing as shown between the bottom section and vertical track. Hang counterbalance lift cable over flag angle. Repeat same process for other side.

**FOR ANGLE MOUNT VERTICAL TRACK ASSEMBLY:** Loosely fasten the slots in the wall angle to the jamb using 5/16" x 1-5/8" lag screws. Tighten lag screws, securing the bottom slot in the wall angle, maintain 3/8" to 5/8" spacing as shown between the bottom section and vertical track. Hang counterbalance lift cable over angle mount. Repeat same process for other side.

## 10 Stacking Sections

**NOTE:** Refer to door section identification, located in the pre-installation section of this manual to determine what size sections you need to use as your intermediate I (second) section and intermediate II (third) section (if applicable). Measure your sections to make sure they are the correct height as indicated on the chart.

**NOTE:** Make sure graduated end and center hinges are flipped down, when stacking another section on top.

With assistance, lift second section and guide the track rollers into the vertical tracks. Keeping the sections vertically aligned, lower section until it is seated against bottom section.

**FOR CENTER HINGE(S) AND OR HALF CENTER HINGE(S):** Flip a upper hinge leaf up and use it as a template. Mark and pre-drill (2) 1/8" pilot holes, 1" deep into the section with a 1/8" drill bit.

**IMPORTANT:** BE EXTREMELY CAREFUL NOT TO DRILL THRU THE SECTION. ONLY DRILL 1" DEEP.

Attach the center hinge upper leaf to the section using (2) 1/4" - 14 x 1" lag screws. Repeat same process for other center hinge(s) and or half center hinge(s).

**FOR GRADUATED END HINGES:** Starting with the outer graduated end hinges, flip the upper hinge leaf up and use it as a template. Mark and pre-drill (2) 9/32" diameter holes through the section. Attach the upper hinge leaf to the section using (2) 1/4" - 20 x 2-1/4" carriage bolts and (2) 1/4" - 20 flange hex nuts. Repeat same process for the other side.

**IF YOU HAVE DOUBLE GRADUATED END HINGES:** Flip the inner upper hinge leaf up and use it as a template. Mark and pre-drill (2) 1/8" pilot holes, 1" deep into the section with a 1/8" drill bit.

**IMPORTANT:** BE EXTREMELY CAREFUL NOT TO DRILL THRU THE SECTION. ONLY DRILL 1"

DEEP.

Attach the inner upper hinge leaf to the section using (2) 1/4" - 14 x 1" lag screws. Repeat same process for the other side.

**IMPORTANT:** PUSH & HOLD THE HINGE LEAFS SECURELY AGAINST THE SECTIONS WHILE SECURING WITH APPROPRIATE FASTENERS. THERE SHOULD BE NO GAP BETWEEN THE HINGE LEAFS AND THE SECTIONS.

Repeat same process for other sections (if applicable), except top section.

## 11 Stacking Top Section

Place the top section in the opening. Install a nail to prevent the top section from falling backwards. Now, flip up the hinge leaves, hold tight against section, and fasten center hinges first and end hinges last (refer to step, Stacking Sections). Vertical track alignment is critical. Position flag angle or wall angle between 1-11/16" (43 mm) to 1-3/4" (44 mm) from the edge of the door; tighten the bottom lag screw. Flag angles must be parallel to the door sections. Repeat for other side.

**IMPORTANT:** THE DIMENSION BETWEEN THE FLAG ANGLES OR WALL ANGLES MUST BE DOOR WIDTH PLUS 3-3/8" (86MM) TO 3-1/2" (89 MM) FOR SMOOTH, SAFE DOOR OPERATION.

**FOR FULLY ADJUSTABLE TRACK OR RIVETED TRACK:** Complete the vertical track installation by securing the jamb bracket(s) and tightening the other lag screws. Push the vertical track against the track rollers so that the track rollers are touching the deepest part of the curved side of the track; tighten all the track bolts and nuts. Repeat for other side.

**FOR ANGLE MOUNT TRACK:** Complete the vertical track installation by securing the jamb bracket(s) and or tightening the other lag screws. Push the vertical track against the track rollers so that the track rollers are touching the deepest part of the curved side of the vertical track, as shown. Repeat for other side.

## 12 Attaching Horizontal Tracks

**NOTE:** Depending on your door, you may have Fully Adjustable Flag Angles, Riveted Vertical Track Assemblies or you may have Angle Mount Vertical Track Assemblies. Refer to Package Contents / Breakdown of Parts, to determine which Flag Angles / Vertical Track Assemblies you have.

### WARNING

**DO NOT RAISE DOOR UNTIL HORIZONTAL TRACKS ARE SECURED AT REAR, AS OUTLINED IN STEP, REAR BACK HANGS, OR DOOR COULD FALL FROM OVERHEAD POSITION CAUSING SEVERE OR FATAL INJURY.**

**IF YOU HAVE FULLY ADJUSTABLE FLAG ANGLES OR RIVETED TRACK ASSEMBLIES:** To install horizontal track, place the top rail end over the top track roller of the top section. Align the bottom rail end of the horizontal track with the top of the vertical track. Tighten the bottom rail of the horizontal track to the flag angle with (2) 1/4" - 20 x 9/16" track bolts and (2) 1/4" - 20 flange hex nuts.

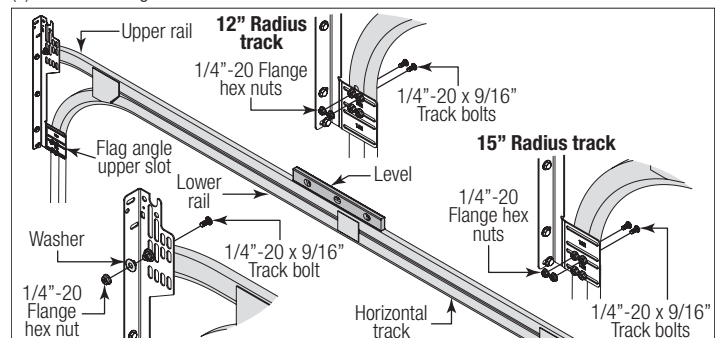

**IF YOU HAVE ANGLE MOUNT VERTICAL TRACK ASSEMBLIES:** To install horizontal track, place the top rail end over the top track roller of the top section. Align the bottom rail end of the horizontal track with the top of the vertical track. Tighten the bottom rail of the horizontal track to the angle mount with (2) 1/4" - 20 x 9/16" track bolts and (2) 1/4" - 20 flange hex nuts.

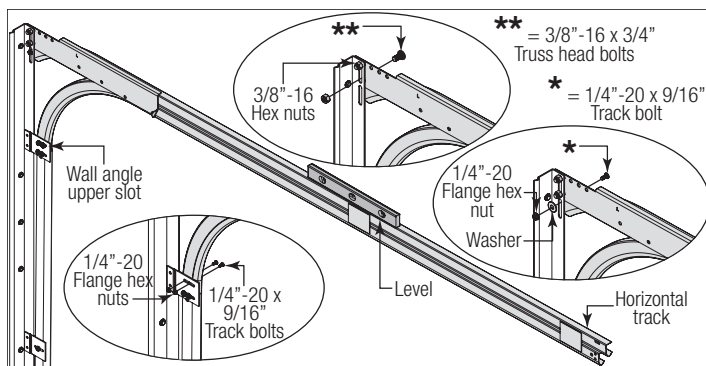

Next level the horizontal track assembly and bolt the top rail of the horizontal track to the encountered slot in the flag angle / angle mount using (1) 1/4" - 20 x 9/16" track bolt, (1) 1/4" - 20 flange hex nut and (1) 5/16" washer.

**NOTE:** If you have angle mount, bolt the top rail of the horizontal track to the encountered slots in the angle mount using (2) 3/8" - 16 x 3/4" truss head bolts, (2) 3/8" - 16 hex nuts. Repeat for other side.

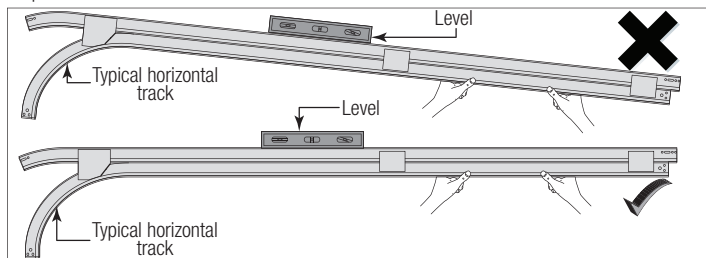

Next remove the nail that was temporarily holding the top section in place, installed in step, Top Section.

**IMPORTANT:** FAILURE TO REMOVE NAIL BEFORE ATTEMPTING TO RAISE DOOR COULD CAUSE PERMANENT DAMAGE TO TOP SECTION.

## 13

### Adjusting Top Fixtures

**NOTE:** Refer to Package Contents / Breakdown of Parts, to determine which Top Fixtures Assemblies you have.

With horizontal tracks installed, you can now adjust the top fixtures. Vertically align the top section of the door with the lower sections. Once aligned, position the top fixture slide(s), out against the horizontal track. Maintaining the slide's position, tighten the 1/4" - 14 x 1" lag screws to secure each of the top fixtures.

# COUNTERBALANCE INSTALLATION INSTRUCTIONS

## 14

### Attaching End Bearing Brackets

**NOTE:** Right and left hand is always determined from inside the garage looking out.

**NOTE:** Identify the end bearing brackets supplied with your door. Refer to Illustrations below, Package Contents or Breakdown of Parts, to determine which end bearing brackets you have.

**NOTE:** End bearing brackets are right and left hand.

**NOTE:** Prior to fastening end bearing brackets to the jamb, pilot drill using a 3/16" drill bit.

Align the bottom edge of left end bearing bracket with the top edge of the flag angle. Maintaining this alignment, also align the right edge of the end bearing bracket with the right edge of the flag angle. Secure the end bearing bracket to the jamb using (3) 5/16" x 1-5/8" lag screws, as shown. Repeat same process for the other side.

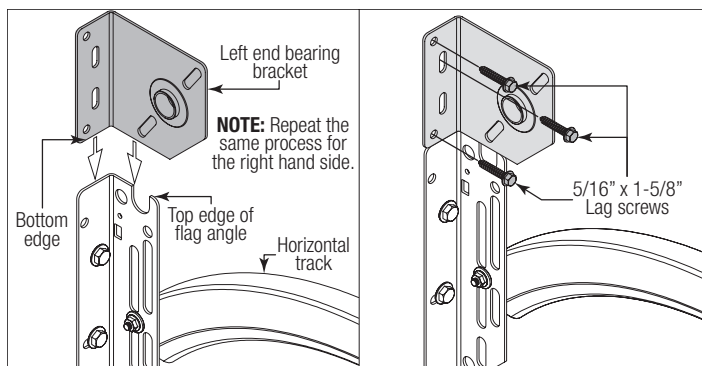

Position the left hand end bearing bracket up against the jamb and on the horizontal track, as shown. Fasten the left hand end bearing bracket to the horizontal track with (1) 3/8" - 16 x 3/4" truss head bolt and (1) 3/8" - 16 nut. Secure the left hand end bearing bracket to the jamb using (3) 5/16" x 1-5/8" lag screws. Repeat same process for the other side.

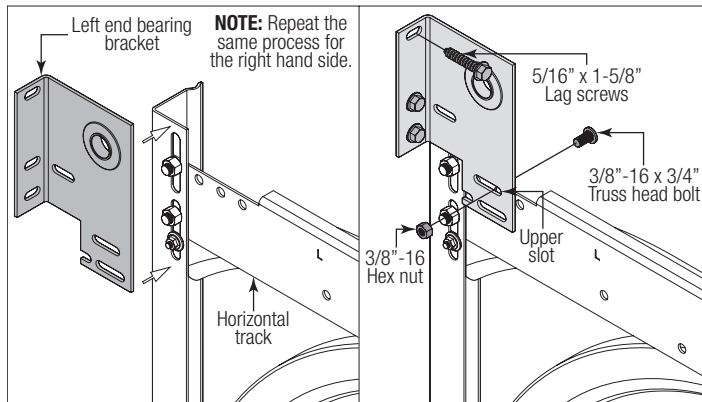

## 15

### Attaching Center Bracket to Wall

**NOTE:** Refer to Package Contents / Parts Breakdown, to determine if your door came with a coupler assembly. If your door came with a coupler assembly, the mounting surface needs to be a minimum of 17" wide. The two center bearing brackets will need to be spaced 12" to 14" apart at the center of the door, as shown.

**NOTE:** Prior to fastening center bracket(s) to the header, pilot drill using a 3/16" drill bit.

**NOTE:** If your door came with (4) springs, each of the outer springs mounting surface will need to be a minimum of 3" wide.

**NOTE:** If needed, measure the diameter of your springs. If you have a one piece shaft with 3-3/4" diameter springs, they do not share center brackets and do not have a coupler assembly.

First, locate the center of the door. Mark a vertical pencil line on the mounting surface above the door, at the center. Measure from the center of the bearing, in one of the end bearing brackets, downwards, to the top of the door. Using that measurement, measure that distance upwards from the top of the door to the mounting surface and mark a horizontal pencil line which intersects the vertical pencil line.

**IF YOUR DOOR DID NOT COME WITH A CENTER COUPLER ASSEMBLY OR USES TORSION SPRINGS LESS THAN 3-3/4" ID:** Mark a vertical pencil line on the mounting surface above the door, at the center. Align the edge of the center bracket with the vertical pencil line and the center of the center bracket with the horizontal pencil line; this is to ensure the torsion shaft is level between the center and end bearing brackets.

**NOTE:** On some single spring doors, the spring can be longer than half the opening width. If your spring is longer, then the center bracket must be mounted off center for the spring to fit properly. Measure spring length adding room for spring growth during winding, to determine appropriate center bracket location.

**IF YOUR DOOR DID COME WITH A CENTER COUPLER ASSEMBLY OR 3-3/4" ID TORSION SPRINGS:** Mark a vertical pencil line on the mounting surface above the door, at the center. Split the difference up and position the (2) center bearing brackets apart from each other. Mark two vertical pencil lines, one for each center bearing bracket onto the mounting surface above the door.

**NOTE:** If your door came with a center coupler assembly or if it utilizes 3-3/4" springs, the springs will not share a center bracket.

**NOTE:** If your door has (4) springs, split the distance between the center of the door and the end bracket on each side to locate the intermediate center brackets.

Attach the center bracket(s) to the mounting surface, using 5/16" RED HEAD lag screws, as shown.

**IMPORTANT:** USE A 5/16" X 2-1/2" RED HEAD LAG SCREW INSTEAD OF THE 5/16" X 1-5/8" RED HEAD LAG SCREW IF MOUNTING SURFACE IS COVERED BY DRYWALL. THE LAG SCREW MUST BE ATTACHED THROUGH THE BOTTOM HOLE OF THE CENTER BRACKET(S).

IF MOUNTING SURFACE IS A 2" X 6" BOARD INSTALLED ON TOP OF MASONRY, DRILL A CLEARANCE HOLE IN MASONRY FOR THE 5/16" X 2-1/2" RED HEAD LAG SCREWS.

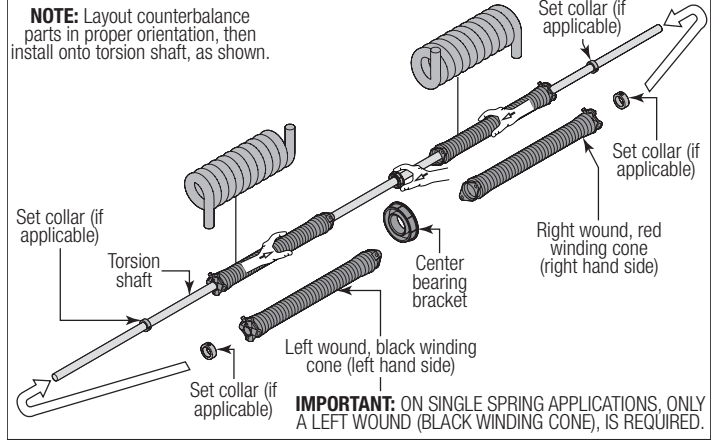
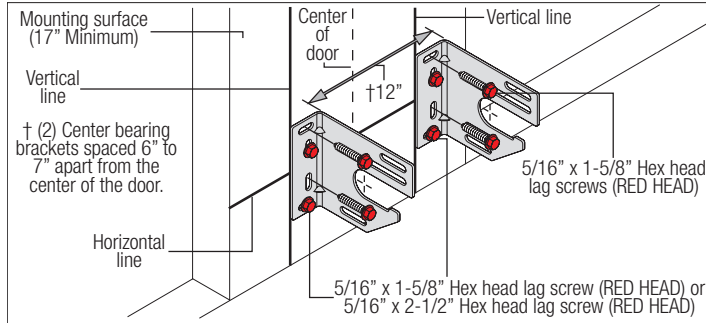
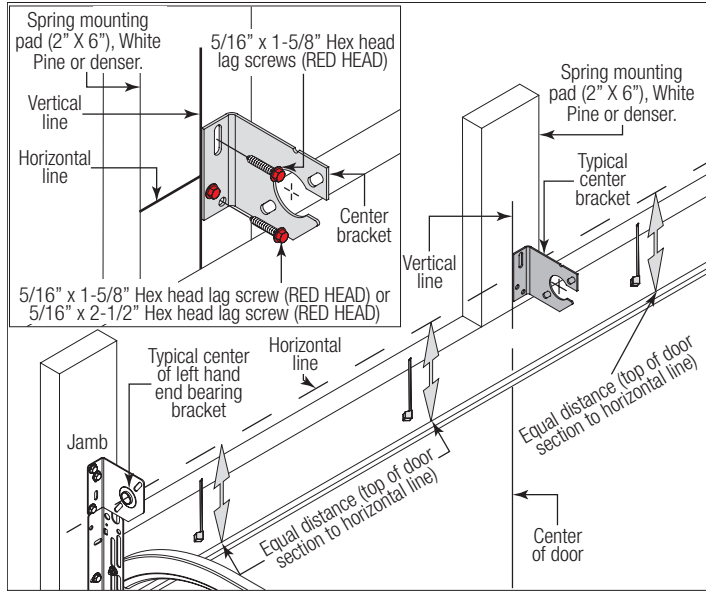

With assistance, pick up the torsion spring assembly and slide one end of the torsion shaft / torsion keyed shaft into the center bracket. Slide the other end of the torsion shaft / torsion keyed shaft into the other end bearing bracket. Position the torsion shaft / torsion keyed shaft so that equal amounts of the shaft extend from each end bearing bracket.

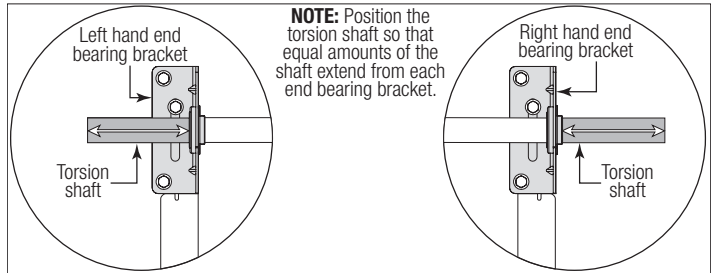
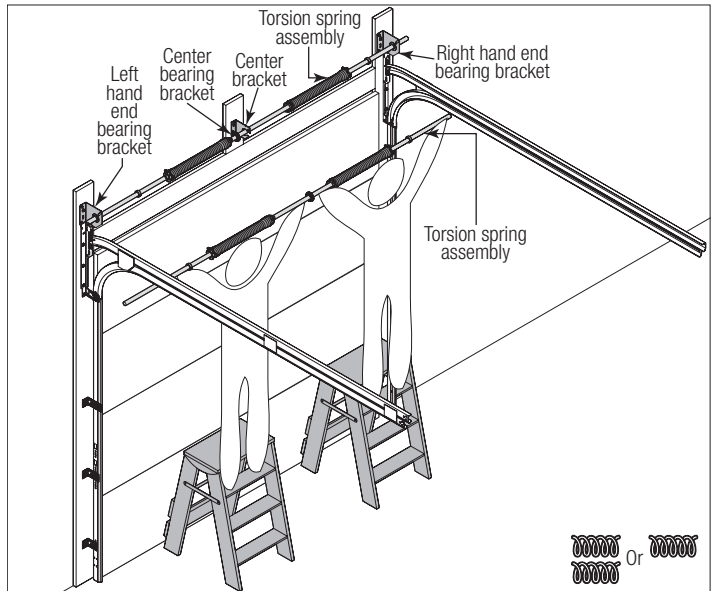

**IF YOU HAVE A COUPLER ASSEMBLY:** Disassemble the coupler assembly by removing the (3) 3/8" - 16 x 1-3/4" hex head screws and the (3) 3/8" - 16 nylon hex lock nuts from the coupler halves. Loosen the set screws. Set the components aside.

## 16 Torsion Spring Assembly

**NOTE:** Refer to the Package Contents and or Parts Breakdown to determine if your door came with a coupler assembly.

**IMPORTANT:** RIGHT AND LEFT HAND IS ALWAYS DETERMINED FROM INSIDE THE BUILDING LOOKING OUT.

**IMPORTANT:** IDENTIFY THE TORSION SPRINGS PROVIDED AS EITHER RIGHT WOUND (RED WINDING CONE), WHICH GOES ON THE RIGHT HAND SIDE OR LEFT WOUND (BLACK WINDING CONE), WHICH GOES ON THE LEFT HAND SIDE.

**IMPORTANT:** ON SINGLE SPRING APPLICATIONS, ONLY A LEFT WOUND (BLACK WINDING CONE), WHICH GOES ON THE LEFT HAND SIDE IS REQUIRED.

**NOTE:** The set screws used on all torsion winding cones and cable drums are colored red. DO NOT identify right and left hand by the set screw color.

**IF YOU DON'T HAVE A COUPLER ASSEMBLY:** Facing the inside of the door, lay the torsion shaft on the floor. Lay the torsion spring with the red winding cone at the right end of the torsion shaft. Lay the torsion spring with the black winding cone at the left end of the torsion shaft. Slide the center bracket bearing onto the torsion shaft followed by the torsion springs and set collars (if applicable).

**IMPORTANT:** THE CENTER BRACKET BEARING / TORSION SPRING(S) AND THE SET COLLARS (IF APPLICABLE) MUST BE POSITIONED, AS SHOWN.



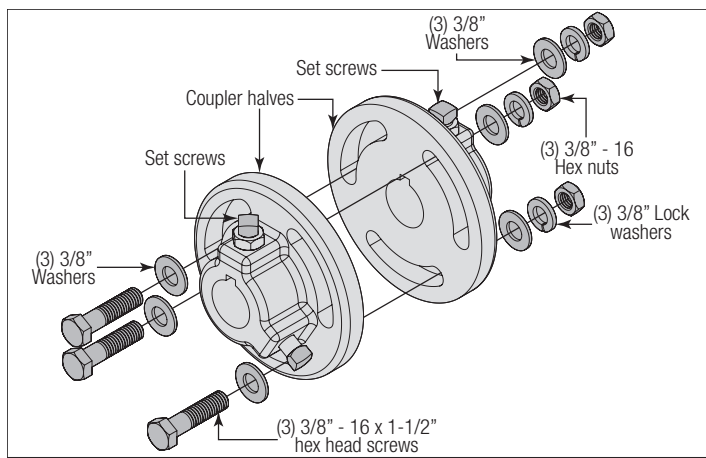

Facing the inside of the door, lay the (2) torsion keyed shafts on the floor. One torsion keyed shaft on the left hand side and the other torsion keyed shaft on the right hand side. Starting on the left hand side, lay one of the coupler halves, the center bearing, torsion spring with the black winding cone and one set collar at the left end of the torsion keyed shaft. Next on the right hand side, lay the other coupler half, center bearing, the torsion spring with the red winding cone and one set collar at the right end of the torsion keyed shaft. Slide the coupler halves, center bearings onto the torsion keyed shafts followed by the torsion springs and the set collars, as shown.

**IMPORTANT:** THE COUPLER HALVES, CENTER BEARINGS, TORSION SPRINGS AND THE SET COLLARS MUST BE POSITIONED, AS SHOWN.

Slide the flat edge of the coupler half flush with the side edge of the torsion keyed shaft. Insert (1) key into the slot of both the coupler half and the slot in the torsion keyed shaft. Tighten the (2) set screws and the locking nut to secure the coupler half to the torsion keyed shaft, as shown.

**NOTE:** Tighten the set screws to 14-15 ft. lbs. of torque (once set screws contact the shaft, tighten set screws one full turn). Repeat the same process for the other coupler half.

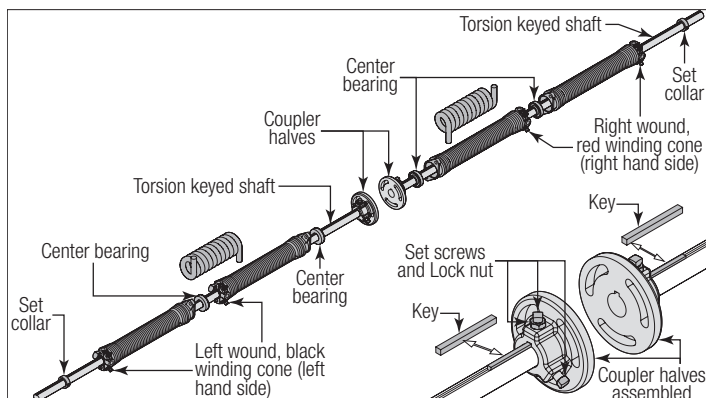
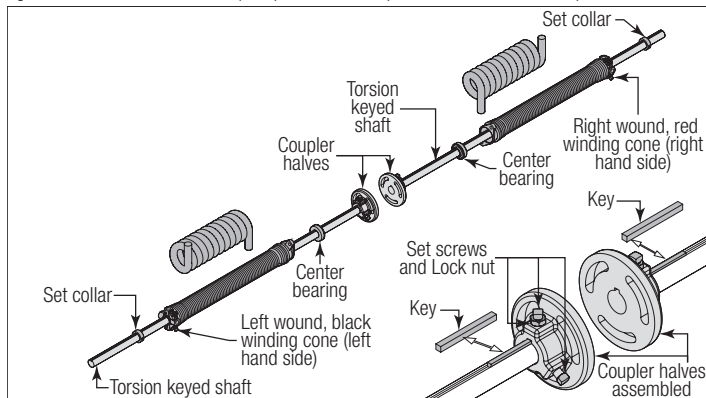

With assistance and starting on the left hand side of door, pick up the left hand torsion spring assembly and slide one end of the torsion keyed shaft through the end bearing bracket. Lay the other side of the torsion keyed shaft into the center bracket. Repeat the same process for the right hand torsion spring assembly. Position both torsion keyed shafts so that equal amounts of the shafts extend from each end bearing brackets.

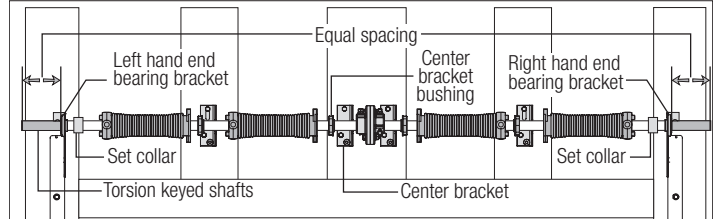
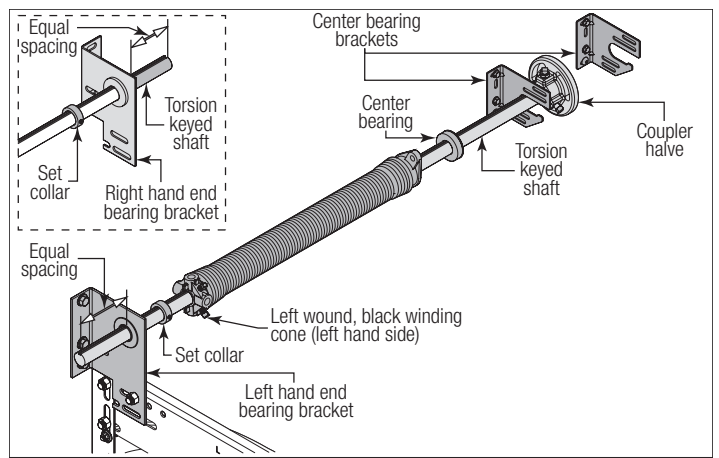

## 17 Attaching Springs to Center Bracket

**IMPORTANT:** THE SPRING WARNING TAG(S) SUPPLIED MUST BE SECURELY ATTACHED TO THE STATIONARY SPRING CONE(S) IN PLAIN VIEW. SHOULD A REPLACEMENT SPRING WARNING TAG BE REQUIRED, CONTACT WAYNE DALTON FOR FREE REPLACEMENTS.

**NOTE:** Measure the diameter of your springs. If your spring diameter is 3-3/4", the springs do not share center brackets. If your spring diameter is either 2" or 2-5/8", then two springs will share the same center bracket, unless a coupler assembly is provided.

**IF YOU DON'T HAVE A COUPLER ASSEMBLY:** Slide center bracket bearing into the spring. Align the stationary spring cone(s) with the holes in the center bracket bearing assembly. Secure the torsion spring(s) to the center bracket bearing assembly with (2) 3/8" - 16 x 1-1/2" hex head bolts and (2) 3/8" - 16 nuts.

**IMPORTANT:** NEVER USE MORE THAN ONE BEARING WHEN ATTACHING TWO SPRINGS TO ONE CENTER BRACKET.

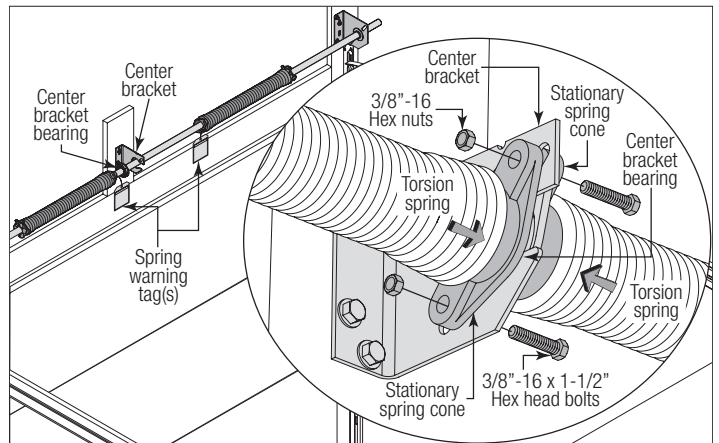

**IF YOU HAVE A COUPLER ASSEMBLY:** Slide center bracket bushing into the spring. Align the stationary spring cone with the holes in the center bracket. Secure the torsion spring to the center bracket with (2) 3/8" - 16 x 1-1/2" hex head bolts and (2) 3/8" - 16 nuts. Repeat the same process for the other center bearing bracket. At the middle of the two center bearing brackets, re-assemble the coupler assembly by loosely fastening the coupler halves together using the (3) 3/8" - 16 x 1-3/4" hex head screws and the (3) 3/8" - 16 nylon hex lock nuts, as shown.

**NOTE:** Ensure both torsion keyed shafts have equal amounts of the shafts extending from each end bearing bracket.

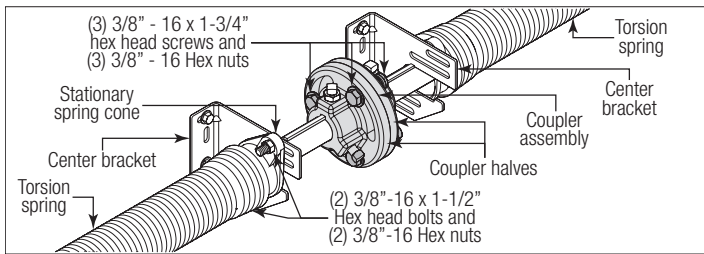
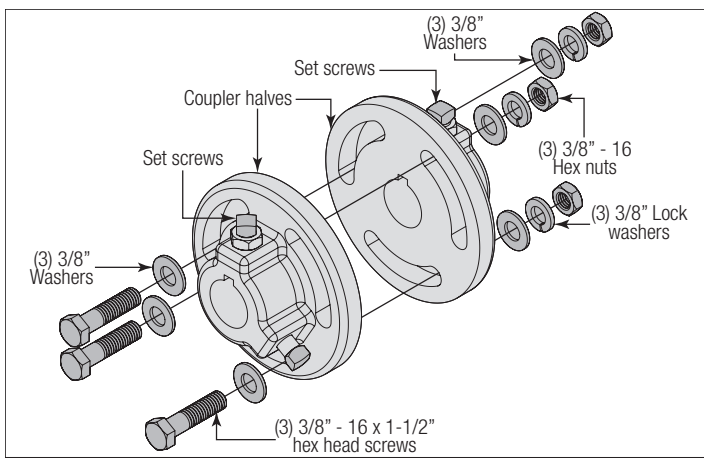

## 18 Attaching Counterbalance Lift Cables

**NOTE:** Always assemble the left hand cable and cable drum first to help maintain equal cable tension on both sides of the door.

Starting on the left hand slide the red cable drum onto the torsion shaft / torsion keyed shaft(s). Hook the counterbalance lift cable into the left hand cable drum and thread the counterbalance lift cable up and around the front side of the cable drum. Slide the left hand cable drum up against the left hand end bearing bracket.

**NOTE:** If you have torsion keyed shaft(s), insert (1) key into the slot of both the cable drum and the slot in the torsion keyed shaft, as shown.

Counterbalance lift cable should terminate at the 3 o'clock position. Tighten the set screws in the drum to 14-15 ft. lbs. of torque (once set screws contact the shaft, tighten screws one full turn).

Rotate the left hand drum and torsion shaft until counterbalance lift cable is taut. Attach locking pliers to the torsion shaft and brace locking pliers up against jamb to keep counterbalance lift cable taut. Repeat for right hand side using the right hand side the black cable drum.

**IMPORTANT:** VERIFY THAT THERE ARE NO OBSTRUCTIONS IN THE TRAVEL PATH OF THE DOOR SECTIONS OR COUNTERBALANCE LIFT CABLES.

**IMPORTANT:** INSPECT EACH COUNTERBALANCE LIFT CABLE MAKING SURE IT IS SEATED PROPERLY ONTO THE CABLE DRUM AND THAT BOTH COUNTERBALANCE LIFT CABLES HAVE EQUAL TENSION.

### CHECK COUNTERBALANCE LIFT CABLES FOR EQUAL TENSION:

1. Attach locking pliers to track above top roller.
2. Grasp cable at approximate mid-door height location.
3. Draw cable toward you about 1/2" to 1" and release, noting the response of the cable.
4. Repeat above steps for other cable.
5. Adjust cable tension as needed until right and left cables both respond the same. Once the counterbalance cables are set and if applicable tighten the coupler assembly together by tightening the (3) 3/8" - 16 nylon hex lock nuts to secure the coupler halves together.

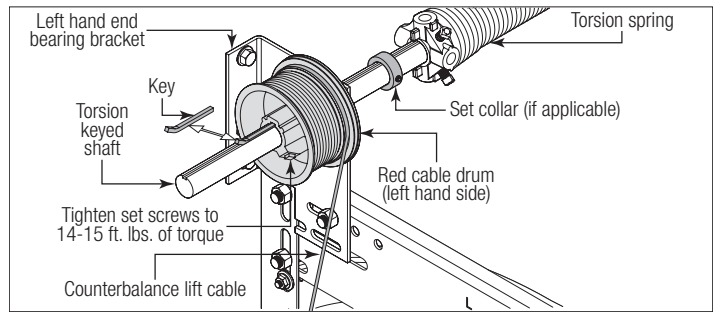
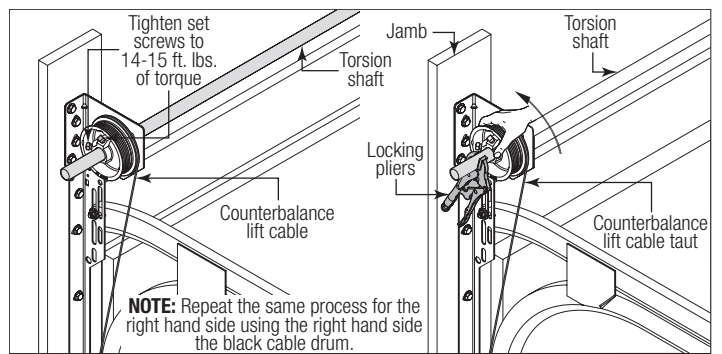
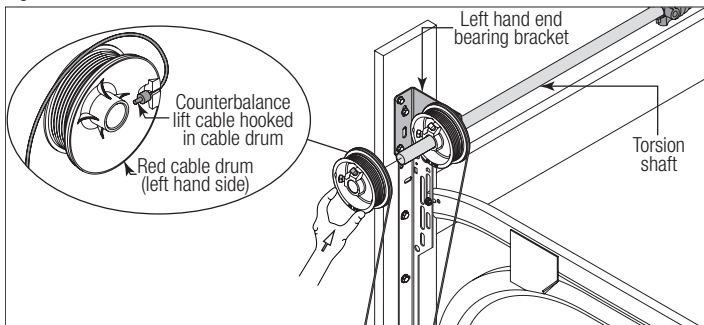

## 19 Set Collars

**NOTE:** If your door did not come with set collars, then skip this step.

Slide each of the set collars up against the inside surface of the end bearing brackets, with the set screw facing directly away from the header. Tighten the set screw in each of the set collars to the torsion shaft to 14-15 ft. lbs. of torque (once set screw contacts the shaft, tighten set screw one full turn).

**IMPORTANT:** PRIOR TO TIGHTENING THE SET SCREWS IN THE SET COLLARS, AVOID PLACING THE SET SCREWS IN THE KEYWAYS OF TORSION KEYPED SHAFT(S).

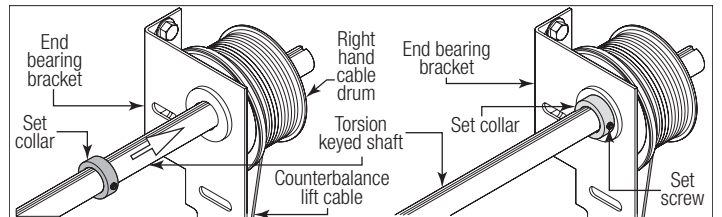

## 20 Chalking Torsion Spring(s)

**NOTE:** If your springs have stenciling, then skip this step.

Draw a chalk line horizontally along the center of the torsion spring coil(s). As the torsion spring is wound, the chalk line will create a spiral. This spiral can be used to count and determine the number of turns that are applied on the torsion spring.

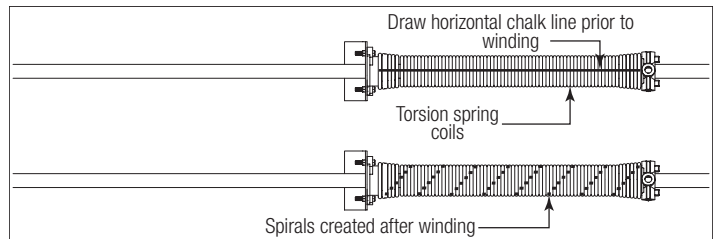

## 21 Securing Door for Spring Winding

With the door in the fully closed position, place locking pliers onto both vertical tracks just above the third track roller. This is to prevent the garage door from rising while winding springs.

**NOTE:** Check the following before attempting to wind torsion spring(s):

- a. Counterbalance lift cables are secured at bottom corner brackets.
- b. Counterbalance lift cables are routed unobstructed to cable drums.

- c. Counterbalance lift cables are correctly installed and wound onto cable lift drums.
- d. Counterbalance lift cables are taut and have equal tension on both sides.
- e. Cable lift drums are against end bearing brackets and set screws are tight.
- f. Torsion spring or springs are installed correctly.
- g. Review the label attached to the spring warning tag, to determine number of spring turns required.

**NOTE:** Door **MUST** be closed and locked when winding or making any adjustments to the torsion spring(s).

## ⚠️ WARNING

**FAILURE TO ENSURE DOOR IS IN A CLOSED POSITION AND TO PLACE LOCKING PLIERS ONTO VERTICAL TRACK CAN ALLOW DOOR TO RISE AND CAUSE SEVERE OR FATAL INJURY.**

Winding Bars (Steel Rods)	Size Of Winding Bar (Inches)	Spring Inner Diameter Used On
	1/2" dia. x 18"	2" and 2-5/8"
	5/8" dia. x 24"	3-3/4"

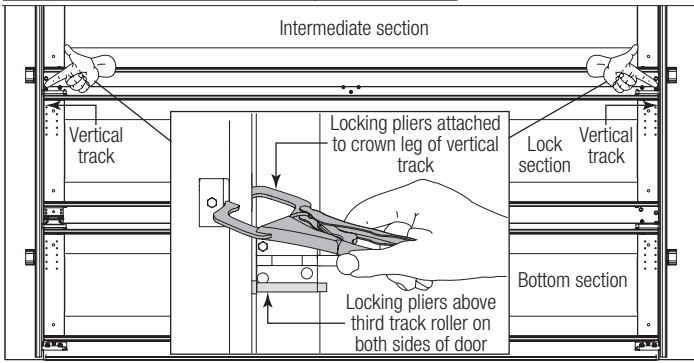

## 22

### Winding Spring(s)

## ⚠️ WARNING

**WINDING SPRING IS AN EXTREMELY DANGEROUS PROCEDURE AND SHOULD BE PERFORMED ONLY BY A TRAINED DOOR SYSTEM TECHNICIAN USING PROPER TOOLS AND INSTRUCTIONS.**

## ⚠️ WARNING

**USE ONLY SPECIFIED WINDING BARS, AS STATED IN STEP SECURING DOOR FOR SPRING WINDING (D8). DO NOT SUBSTITUTE WITH SCREWDRIVERS, PIPE, ETC. OTHER TOOLS MAY FAIL OR RELEASE FROM THE SPRING CONE AND CAUSE SEVERE OR FATAL INJURY.**

## ⚠️ WARNING

**PRIOR TO WINDING THE SPRING, ENSURE YOU'RE WINDING IN THE PROPER DIRECTION AS SHOWN BELOW. OTHERWISE THE SPRING FITTING MAY RELEASE FROM SPRING AND RESULT IN SEVERE OR FATAL INJURY.**

Check the label attached to the spring warning tag for the required number of complete turns to balance your door.

#### HOW TO WIND TORSION SPRINGS:

1. Insert one winding rod snugly into winding cone, to full socket depth
2. Maintaining a tight grip on the winding rod rotate it slowly in the proper direction, as shown below.
3. If there is any slippage of the winding rod in the winding cone socket, reverse the direction of winding and return the cone to its original position. Remove the winding rod from the winding cone socket. Reseat the winding rod in the socket. Start over at Step #1.
4. When the winding rod is vertical above the winding cone, insert another winding rod into one of the other sockets, being careful to seat it snugly and at full socket depth.
5. Hold the spring with the second winding bar, and remove the first.
6. Repeat Steps #2 through #5 until the complete turns have been applied.

**IMPORTANT:** AFTER WINDING THE SPRING(S), TIGHTEN THE (2) SET SCREWS TO 14-15 FT. LBS. OF TORQUE IN THE WINDING CONE. ONCE SET SCREWS CONTACT THE SHAFT, TIGHTEN SCREWS ONE FULL TURN.

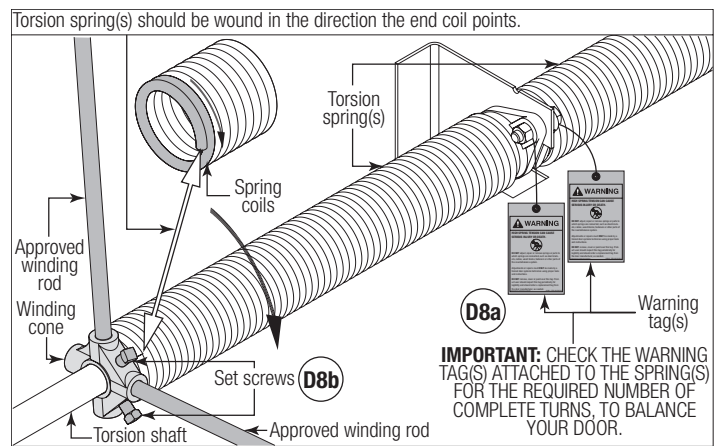

## 23

### Attaching Rear Back Hangs

**IMPORTANT:** HOLD THE DOOR DOWN TO PREVENT IT FROM RISING UNEXPECTEDLY IN THE EVENT THE SPRING(S) WERE OVER-WOUND AND CAUTIOUSLY REMOVE LOCKING PLIERS FROM VERTICAL TRACKS.

Raise the door until the top section and half of the next section are in the horizontal track radius. Do not raise door any further since rear of horizontal tracks are not yet supported.

## ⚠️ WARNING

**RAISING DOOR INTO THE LOOSE HORIZONTAL TRACKS CAN RESULT IN DOOR FALLING AND CAUSE SEVERE OR FATAL INJURY.**

Clamp a pair of locking pliers onto the vertical tracks just above the second track roller on one side, and just below the second track roller on the other side. This will prevent the door from raising or lowering while installing the rear back hangs.

Using the chart below, select the appropriate perforated angle (may not be supplied). Fabricate and install rear back hangs, as shown.

Perforated Angle Gauge Weight Limitations:	
Perforated Angle Gauge	Door Balance Weight
2" x 2" x 12 Gauge	800 lbs. to 1600 lbs.
1-1/4" x 1-1/4" x 13 Gauge	305 lbs. to 610 lbs.
1-1/4" x 1-1/4" x 15 Gauge	220 lbs. to 440 lbs.
1-1/4" x 1-1/4" x 16 Gauge	175 lbs. to 350 lbs.

**NOTE:** If an opener is installed, position horizontal tracks one hole above level when securing them to the rear back hangs.

## ⚠️ WARNING

**KEEP HORIZONTAL TRACKS PARALLEL AND WITHIN 3/4" TO 7/8" FROM DOOR EDGE, OTHERWISE DOOR COULD FALL, RESULTING IN SEVERE OR FATAL INJURY.**

**IMPORTANT:** DO NOT SUPPORT THE WEIGHT OF THE DOOR ON ANY PART OF THE REAR BACK HANGS THAT CANTILEVERS 4" OR MORE BEYOND A SOUND FRAMING MEMBER.

**NOTE:** If rear back hangs are to be installed over drywall, use (2) 5/16" x 2" hex head lag screws and make sure lag screws engage into solid structural lumber.

## ⚠️ WARNING

**FAILURE TO ASSEMBLE AND ATTACH REAR BACK HANGS PROPERLY ACCORDING TO THE ABOVE INSTRUCTIONS MAY RESULT IN DOOR FALLING WHEN RAISED, CAUSING SEVERE OR FATAL INJURY.**

**NOTE:** Perforated angle must be attached to sound framing members and **nails should not be used.**

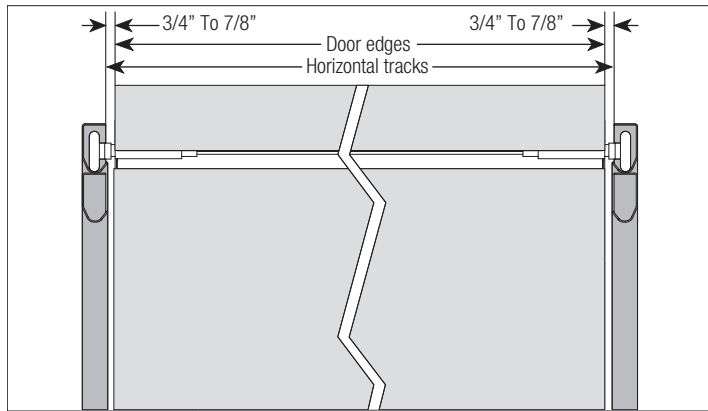
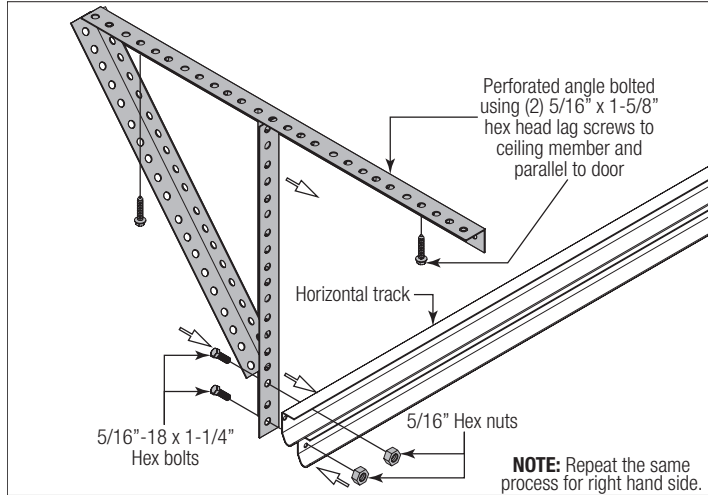
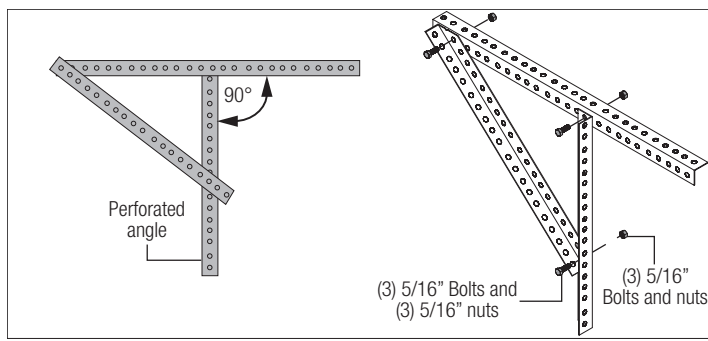

## 24 Attaching Weather Seal

Permanently attach the weatherstrips on both door jambs and header. The weatherstrips were temporarily attached in Preparing the Opening, in the pre-installation section of this manual.

**NOTE:** When permanently attaching the weatherstrips to the jambs, avoid pushing the weatherstrips too tightly against the face of door.

**NOTE:** Door not shown for clarity.

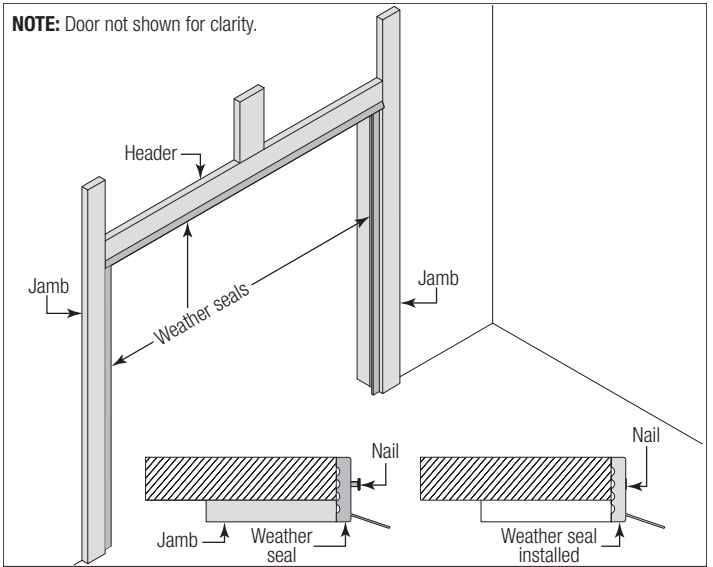

## 25 Balancing Door

Remove locking pliers. Lift door and check its balance. Adjustments to the required number of spring turns stated may be necessary. If door rises off floor more than 2 ft. under spring tension alone, reduce spring tension. If the door is hard to rise or drifts down on its own, add spring tension. A poorly balanced door can cause garage door operator problems.

To adjust spring tension, fully close door. Apply locking pliers to track above third track roller. Place locking pliers on torsion shaft, as shown in D5. Insert a winding rod into the winding cone. Push downward on the winding rod slightly while carefully loosening the set screws in the winding cone.

**IMPORTANT:** BE PREPARED TO SUPPORT THE FULL FORCE OF THE TORSION SPRING ONCE THE SET SCREWS ARE LOOSE.

Carefully adjust spring tension 1/4 turn. Retighten both set screws to 14-15 ft. lbs. of torque in the winding cone and repeat for the other side. Recheck door balance and re-adjust spring tension if needed.

**IMPORTANT:** DO NOT ADJUST MORE THAN 1 TURN FROM THE RECOMMENDED NUMBER OF TURNS.

If the door still does not operate easily, lower the door into the closed position, unwind spring(s) completely, and recheck the following items:

- 1.) Is the door level?
- 2.) Are the torsion shaft and flag angles level and plumb?
- 3.) Does the distance between the flag angles equal door width plus 3-3/8" to 3-1/2"?
- 4.) Do the counterbalance lift cables have equal tension? Adjust if necessary.
- 5.) Rewind the spring(s).
- 6.) Make sure door is not rubbing on jambs.

**IMPORTANT:** IF DOOR STILL DOES NOT BALANCE PROPERLY, THEN CONTACT A TRAINED DOOR SYSTEM TECHNICIAN.

## 26 Label Placement

**IMPORTANT:** USING THE ILLUSTRATION, ATTACH THE APPROPRIATE LABELS TO THE APPROPRIATE LOCATION ON THE SECTION, AS SHOWN.

**NOTE:** The Spring Warning tag(s) are factory attached (one per spring).

**NOTE:** Because of different configurations, some labels may require minor relocations.

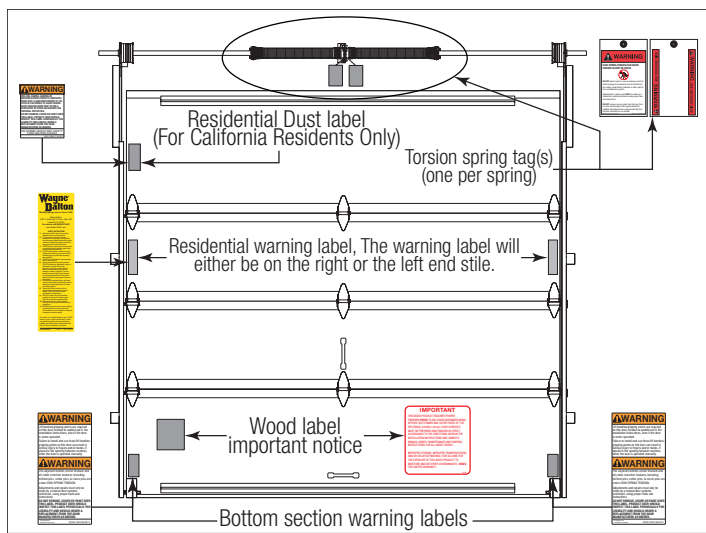

**MANUAL DOOR OPERATION:** For additional information on manual garage door operations go to [www.dasma.com](http://www.dasma.com) and reference TDS 165.

## WARNING

**DO NOT PLACE FINGERS OR HANDS INTO SECTION JOINTS WHEN OPENING AND/OR CLOSING A DOOR. ALWAYS USE LIFT HANDLES / SUITABLE GRIPPING POINTS WHEN OPERATING THE DOOR MANUALLY.**

**OPENING A DOOR:** Make sure the lock(s) are in the unlocked position. Lift the door by using the lift handles / suitable gripping points only. Door should open with little resistance.

**CLOSING A DOOR:** From inside the garage, pull door downward using lift handles / gripping point only. If you are unable to reach the lift handles/ suitable gripping points only, use pull down rope affixed to the side of door. Door should close completely with little resistance.

### USING AN ELECTRIC OPERATOR:

**IMPORTANT:** PULL DOWN ROPES MUST BE REMOVED AND LOCKS MUST BE REMOVED OR MADE INOPERATIVE IN THE UNLOCKED POSITION.

When connecting a drawbar (trolley type) garage door operator to this door, a drawbar operator bracket must be securely attached to the top section of the door, along with any struts provided with the door. Always use the drawbar operator bracket supplied with the door. To avoid possible damage to your door, Wayne Dalton recommends reinforcing the top section with a strut (may or may not be supplied). The installation of the drawbar operator must be according to manufacturer's instructions and force settings must be adjusted properly. Refer to the owner's manual supplied with your drawbar operator for complete details on installation, operation, maintenance and testing of the operator.

**MAINTAINING YOUR GARAGE DOOR:** Before you begin, read all warning labels affixed to the door and the installation instructions and owner's manual. Perform routine maintenance steps once a month, and have the door professionally inspected once a year. Review your Installation Instructions and Owner's Manual for the garage door. These instructions are available at no charge from Wayne Dalton, a division of Overhead Door Corporation, P.O. Box 67, Mt. Hope, OH., 44660, or at [www.Wayne-Dalton.com](http://www.Wayne-Dalton.com). For additional information on garage door/operator maintenance go to [www.dasma.com](http://www.dasma.com) and reference TDS 151, 167 and 179.

### Monthly Inspections:

**1. Visual Inspection:** Closely inspect jambs, header and mounting surface. Any material found not to be structurally sound must be replaced. It may be necessary to uninstall part or all of the door assembly in order to replace defective material. Refer to the supplemental instructions "Removing an Existing Door / Preparing the Opening" at [www.Wayne-Dalton.com](http://www.Wayne-Dalton.com). Inspect the spring(s), counterbalance lift cables, track rollers, pulleys, rear back hangs and other door hardware for signs of worn or broken parts. Tighten any loose screws and/or bolts, except on bottom corner brackets or on the counterbalance assembly. Check exterior surface of the door sections for any minor cracks. Verify door has not shifted right or left in the opening. If you suspect problems, contact a trained door system technician.

## MAINTENANCE

### Cleaning Your Garage Door

**IMPORTANT:** DO NOT USE A PRESSURE WASHER ON YOUR GARAGE DOOR!

An annual inspection of all the surfaces of your garage door(s) will reveal the extent of weathering and the possible need for refinishing. When the finish becomes eroded or thin, clean and prime any areas showing deterioration. Then completely refinish the door, according to the directions, listed below, or the manufacturer's label directions. Proper finishing of the wood substrates to protect your door(s) from the effects of moisture and sunlight is vital in extending the service life and beautifying your garage door(s).

The interior and exterior surfaces, as well as all edges must be properly primed, painted and maintained, to protect and beautify your door. These finishing instructions are intended to achieve both objectives for your wood doors(s).

**NOTE:** Be sure to clean behind weatherstrips on both sides and top of door.

## CAUTION

NEVER MIX CLEANSERS OR DETERGENTS WITH BLEACH.

### GLASS CLEANING INSTRUCTIONS

Clean with a mild detergent solution (same as above) and a soft cloth. After cleaning, rinse thoroughly.

### ACRYLIC CLEANING INSTRUCTIONS

Clean acrylic glazing with nonabrasive soap or detergent and plenty of water. Use your bare hands to feel and dislodge any caked on particles. A soft, grit-free cloth, sponge or chamois may be used to wipe the surface. Do not use hard or rough cloths that will scratch the acrylic glazing. Dry glazing with a clean damp chamois.

**NOTE:** Do not use any window cleaning fluids, scouring compounds, gritty cloths or solvent-based cleaners of any kind.

## WARNING

**GARAGE DOOR SPRINGS, COUNTERBALANCE LIFT CABLES, BRACKETS, AND OTHER HARDWARE ATTACHED TO THE SPRINGS ARE UNDER EXTREME TENSION, AND IF HANDLED IMPROPERLY, CAN CAUSE SEVERE OR FATAL INJURY. ONLY A TRAINED DOOR SYSTEMS TECHNICIAN SHOULD ADJUST THEM, BY CAREFULLY FOLLOWING THE MANUFACTURER'S INSTRUCTIONS.**

## WARNING

**NEVER REMOVE, ADJUST, OR LOOSEN THE BOLTS, SCREWS AND/OR LAG SCREWS ON THE COUNTERBALANCE (END BEARING BRACKETS, DRUMS OR SPRING SYSTEM) OR BOTTOM CORNER BRACKETS OF THE DOOR. THESE BRACKETS ARE CONNECTED TO THE SPRING(S) AND ARE UNDER EXTREME TENSION. TO AVOID POSSIBLE SEVERE OR FATAL INJURY, HAVE ANY SUCH WORK PERFORMED BY A TRAINED DOOR SYSTEMS TECHNICIAN USING PROPER TOOLS AND INSTRUCTIONS.**

### Painting Your Garage Door

Refer to Instruction Insert "**Field Painting Wood Door Sections**".

### Maintaining The Finish On Your Garage Door

If the finish is beginning to fade, the door may require a field applied top clear coat. Depending on environment and usage, this may be necessary after 1 to 3 years of use. Refer to Instruction Insert "**Field Painting Wood Door Sections**".

### Operation And Maintenance

**OPERATING YOUR GARAGE DOOR:** Before you begin, read all warning labels affixed to the door and the installation instructions and owner's manual. When correctly installed, your Wayne Dalton door will operate smoothly. Always operate your door with controlled movements. Do not slam your door or throw your door into the open position, this may cause damage to the door or its components. If your door has an electric opener, refer to the owner's manual to disconnect the opener before performing manual door operation below.

**TORQUEMASTER® PLUS SPRINGS:** Pawl knob(s) (located on the TorqueMaster® end brackets above the door) should be engaged to prevent the door from rapidly descending in case of spring failure or forceful manual operation.

**EXTENSION SPRINGS:** A restraining cable or other device should be installed on the extension spring (located above the horizontal tracks) to help contain the spring if it breaks.

**2. Door Balance:** Periodically test the balance of your door. If you have a garage door drawbar operator, use the release mechanism so you can operate the door by hand when doing this test. Start with the door in the fully closed position. Using handles or suitable gripping points, lift the door to check its balance. Adjust TorqueMaster® or Extension spring(s), if door lifts by itself (hard to pull down) or if door is difficult to lift (easy to pull down). DO NOT attempt to repair or adjust Torsion Springs yourself. To adjust TorqueMaster® or Extension spring(s), refer to your installation instructions and owner's manual. If in question about any of the procedures, do not perform the work. Instead, have it adjusted by a trained door systems technician.

**3. Lubrication:** The door should open and close smoothly. Ensure the door track rollers are rotating freely when opening and closing the door. If track rollers do not rotate freely, clean the door tracks, removing dirt and any foreign substances. Clean and lubricate (use a non-silicon based lubricant) graduated end hinges, center hinges, steel track rollers, bearings and

torsion springs (torsion spring coil surfaces). DO NOT lubricate plastic idler bearings, nylon track rollers, door track. DO NOT oil a cylinder lock, if actuation is difficult use a graphite dust to lubricate.

**CHECK FOR PRESENCE OF SAFETY LABELS:**

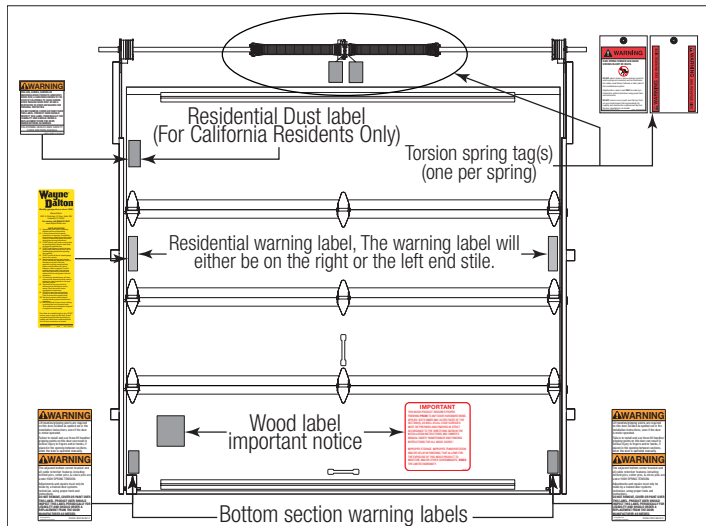

EXPRESS OR IMPLIED, WILL APPLY AFTER THE LIMITED WARRANTY PERIOD HAS EXPIRED. Some states do not allow limitations on how long an implied warranty lasts, so the above limitation may not apply to you.

IN NO EVENT SHALL SELLER BE RESPONSIBLE FOR, OR LIABLE TO ANYONE FOR, SPECIAL, INDIRECT, COLLATERAL, PUNITIVE, INCIDENTAL OR CONSEQUENTIAL DAMAGES, even if Seller has been advised of the possibility of such damages. Such excluded damages include, but are not limited to, loss of use, cost of any substitute product, or other similar indirect financial loss. Some states do not allow the exclusion or limitation of incidental or consequential damages, so the above limitation or exclusion may not apply to you.

Claims under this warranty must be made promptly after discovery, within the applicable warranty period, and in writing to the Seller whose name and address appear below. The purchaser must allow Seller a reasonable opportunity to inspect any Product claimed to be defective prior to removal or any alteration of its condition. Proof of the purchase and/or installation date, and identification as the original purchaser, may be required. There are no established informal dispute resolution procedures of the type described in the Magnuson-Moss Warranty Act.

\* Dark colors shall mean colors as dark as or darker than any of the following Sherwin-Williams Exterior Colors: 7069 Iron Ore (darkgrey), 6447 Evergreens (dark green) or 7510 Chateau Brown (dark brown).

• SELLER: \_\_\_\_\_

• SELLER'S ADDRESS: \_\_\_\_\_

\_\_\_\_\_

# WARRANTY

## Limited warranty Model Series 7100

Wayne Dalton, a division of Overhead Door Corporation ("Seller") warrants to the original purchaser of the **Model Series 7100** ("Product"), subject to all of the terms and conditions hereof, that the Product and all components thereof will be free from defects in materials and workmanship for a period of **One (1) year**, measured from the date of installation:

Seller's obligation under this warranty is specifically limited to repairing or replacing, at its option, any part which is determined by Seller to be defective during the applicable warranty period. Any labor charges are excluded and will be the responsibility of the purchaser.

This warranty gives you specific legal rights, and you may also have other rights which vary from state to state. This warranty is made to the original purchaser of the Product only, and is not transferable or assignable. This warranty applies only to Product installed in a residential or other non-commercial application. It does not cover any Product installed in commercial or industrial building applications. This warranty does not apply to any unauthorized alteration or repair of the Product, or to any Product or component which has been damaged or deteriorated due to misuse, neglect, accident, puncture, drilling of holes (other than as directed by Seller), incorrect installation of hardware, fire, failure to provide necessary maintenance, normal wear and tear, exposure to salt or other corrosive environments, or acts of God or any other cause beyond the reasonable control of Seller. This warranty also specifically excludes all refinishing costs and any inconsistencies or occurrences related to the characteristics or attributes of natural wood, including but not limited to: (i) variations in the color or grain of Product sections, (ii) the emission or secretion of tannins from the Product sections which may stain or alter the color of a painted Product, and (iii) cracking, checking, lifting wood grain or cracking due to natural expansion and contraction of the Product sections.

**SPECIAL PAINTING REQUIREMENTS:** This warranty shall be void if the Product sections are not painted or sealed in accordance with DASMA TDS 162 (available at [www.dasma.com](http://www.dasma.com)) on all sides, including all edges with one (1) coat of exterior grade primer (or stain) and two (2) coats of high quality acrylic latex exterior grade finish paint (or sealer), applied in accordance with the paint or Sealer manufacturer's instructions and Seller's painting and maintenance instructions. Sections must be finished within five (5) days of receipt and prior to installation. Damage caused by exposure of the product to water, moisture, sun or other conditions prior to completion of painting (or Sealing) is excluded. This warranty shall also be void if the Product is painted a dark color, including but not limited to black, dark grey, dark green and dark brown\*. **IMPROPER TRANSPORTATION, STORAGE OR DELAYS IN FINISHING, THAT ALLOWS EXPOSURE OF THE WOOD DOOR SURFACES TO MOISTURE OR OTHER CONTAMINANTS WILL RESULT IN THE WARRANTY BEING VOIDED.**

ALL EXPRESS AND IMPLIED WARRANTIES FOR THE PRODUCT, INCLUDING BUT NOT LIMITED TO ANY IMPLIED WARRANTIES OF MERCHANTABILITY AND FITNESS FOR A PARTICULAR PURPOSE, ARE LIMITED IN TIME TO THE APPLICABLE WARRANTY PERIOD REFLECTED ABOVE. NO WARRANTIES, WHETHER



---

Thank you for your purchase.

---

**PLEASE DO NOT RETURN THIS PRODUCT TO THE STORE**

If you need assistance, please call 1-866-569-3799 (press Option 1) and follow the prompts to contact a customer service representative. They will be happy to handle any questions that you may have.

---

After installation is complete, leave this Installation Instructions And Owner's Manual with the homeowner, or fasten it near garage door for easy reference.