

# Converting

TORQUEMASTER® ONE

TO TORQUEMASTER® PLUS

QUICK START GUIDE

## Table Of Contents

<b>Pre-Installation</b>	<b>2</b>
Important Safety Instructions	2
Preparing the Opening	2
<b>Breakdown Of Parts</b>	<b>3</b>
<b>Installation</b>	<b>4</b>
Removing Old TorqueMaster® One Counterbalance System	4
Inspecting Old Flag Angles	5
Installing New TorqueMaster® Plus Counterbalance System	8
<b>Maintenance</b>	<b>13</b>
Operation And Maintenance	13

### **PLEASE DO NOT RETURN THIS PRODUCT TO THE STORE**

Please Do Not Return This Product To The Store. Please call 1-866-569-3799 (Press Option 1) and follow the prompts to contact the appropriate customer service agent. They will be happy to handle any questions that you may have.

### **QUICK START GUIDE IMPORTANT NOTICES!**

**This Quick Start Guide is only meant to be used as an aid** and / or introduction to garage door installation, and does not replace the complete Installation Instructions and Owner's manual available on the web at **[www.Wayne-Dalton.com](http://www.Wayne-Dalton.com)**.

Wayne Dalton highly recommends that you read and fully understand the Installation Instructions and Owner's Manual before you attempt this installation.

To avoid possible injury, read the enclosed instructions carefully before installing and operating the garage door. Pay close attention to all warnings and notes. After installation is complete, fasten this manual near garage door for easy reference.

The complete Installation Instructions and Owner's Manual are available at no charge from:

Wayne Dalton, a Division Of Overhead Door Corporation,  
P.O. Box 67, Mt. Hope, OH., 44660, Or Online At [www.Wayne-Dalton.com](http://www.Wayne-Dalton.com)

## Important Safety Instructions

### DEFINITION OF KEY WORDS USED IN THIS MANUAL:

#### **WARNING**

INDICATES A POTENTIALLY HAZARDOUS SITUATION WHICH, IF NOT AVOIDED, COULD RESULT IN SEVERE OR FATAL INJURY.

#### **CAUTION**

PROPERTY DAMAGE OR INJURY CAN RESULT FROM FAILURE TO FOLLOW INSTRUCTIONS.

**IMPORTANT:** REQUIRED STEP FOR SAFE AND PROPER DOOR OPERATION.

**NOTE:** Information assuring proper installation of the door.

READ THESE INSTRUCTIONS CAREFULLY BEFORE ATTEMPTING INSTALLATION. IF IN QUESTION ABOUT ANY OF THE PROCEDURES, DO NOT PERFORM THE WORK. INSTEAD, HAVE A TRAINED DOOR SYSTEMS TECHNICIAN DO THE INSTALLATION OR REPAIRS.

1. READ AND FOLLOW ALL INSTALLATION INSTRUCTIONS.
2. Wear protective gloves during installation to avoid possible cuts from sharp metal edges.
3. It is always recommended to wear eye protection when using tools, otherwise eye injury could result.
4. Avoid installing your new door on windy days. Door could fall during the installation causing severe or fatal injury.
5. Doors 12'-0" wide and over should be installed by two persons, to avoid possible injury.
6. Operate door only when it is properly adjusted and free from obstructions.
7. If a door becomes hard to operate, inoperative or is damaged, immediately have necessary adjustments and/ or repairs made by a trained door system technician using proper tools and instructions.
8. DO NOT stand or walk under a moving door, or permit anybody to stand or walk under an electrically operated door.
9. DO NOT place fingers or hands into open section joints when closing a door. Use lift handles/ gripping points when operating door manually.
10. DO NOT permit children to operate garage door or door controls. Severe or fatal injury could result should the child become entrapped between the door and the floor.
11. Due to constant extreme spring tension, do not attempt any adjustment, repair or alteration to any part of the door, especially to springs, spring brackets, bottom corner brackets, fasteners, counterbalance lift cables or supports. To avoid possible severe or fatal injury, have any such work performed by a trained door systems technician using proper tools and instructions.
12. On electrically operated doors, pull down ropes must be removed and locks must be removed or made inoperative in the open (unlocked) position.
13. Top section of door may need to be reinforced when attaching an electric opener. Check door and/ or opener manufacturer's instructions.
14. Visually inspect door and hardware monthly for worn and or broken parts. Check to ensure door operates freely.
15. Test electric opener's safety features monthly, following opener manufacturer's instructions.
16. NEVER hang tools, bicycles, hoses, clothing or anything else from horizontal tracks. Track systems are not intended or designed to support extra weight.
17. This door may not meet the building code wind load requirements in your area. For your safety, you will need to check with your local building official for wind load code requirements and building permit information.

**After installation is complete, fasten this manual near the garage door.**

**IMPORTANT:** STAINLESS STEEL OR PT2000 COATED LAG SCREWS MUST BE USED WHEN INSTALLING CENTER BEARING BRACKETS, END BRACKETS, JAMB BRACKETS, DRAWBAR OPERATOR MOUNTING/ SUPPORT BRACKETS AND DISCONNECT BRACKETS ON TREATED LUMBER (PRESERVATIVE-TREATED). STAINLESS STEEL OR PT2000 LAG SCREWS ARE NOT NECESSARY WHEN INSTALLING PRODUCTS ON UN-TREATED LUMBER.

**NOTE:** It is recommended that 5/16" lag screws are pilot drilled using a 3/16" drill bit, prior to fastening.

**IMPORTANT:** WHEN INSTALLING 5/16" LAG SCREWS USING AN ELECTRIC DRILL/ DRIVER, THE DRILL/ DRIVERS CLUTCH MUST BE SET TO DELIVER NO MORE THAN 200 IN-LBS OF TORQUE. FASTENER FAILURE COULD OCCUR AT HIGHER SETTINGS.

#### **WARNING**

PRIOR TO WINDING OR MAKING ADJUSTMENTS TO THE SPRINGS, ENSURE YOU'RE WINDING IN THE PROPER DIRECTION AS STATED IN THE INSTALLATION INSTRUCTIONS. OTHERWISE, THE SPRING FITTINGS MAY RELEASE FROM SPRING IF NOT WOUND IN THE PROPER DIRECTION AND COULD RESULT IN SEVERE OR FATAL INJURY.

**IMPORTANT:** RIGHT AND LEFT HAND IS ALWAYS DETERMINED FROM INSIDE THE BUILDING LOOKING OUT.

## Preparing the Opening

**IMPORTANT:** IF YOU JUST REMOVED YOUR EXISTING DOOR OR YOU ARE INSTALLING A NEW DOOR, COMPLETE ALL STEPS IN PREPARING THE OPENING.

# BREAKDOWN OF PARTS

**NOTE:** The illustrations shown on this page are general representations of the door parts. Each specific door models may have unique variations.

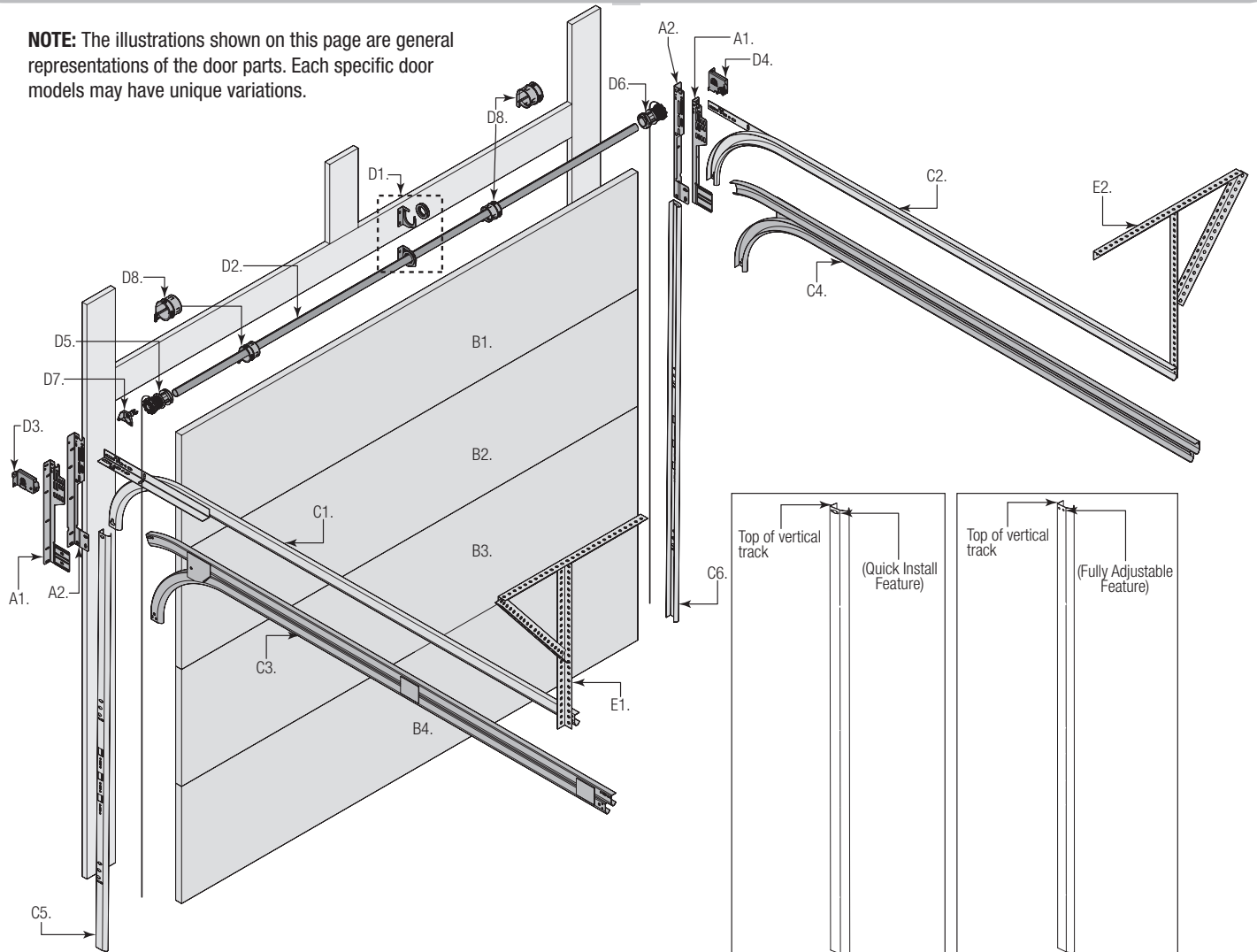

## A. FLAG ANGLES:

- A1. Quick Install (Q.I.) Flag Angles
- A2. Fully Adjustable (F.A.) Flag Angles

## B. EXISTING STACKED SECTIONS:

- B1. Top Section
- B2. Intermediate(s) Section
- B3. Lock Section
- B4. Bottom Section

## C. EXISTING TRACKS:

- C1. Left Hand Standard Lift Horizontal Track Assembly
- C2. Right Hand Standard Lift Horizontal Track Assembly
- C3. Left Hand Low Headroom Horizontal Track Assembly
- C4. Right Hand Low Headroom Horizontal Track Assembly
- C5. Left Hand Vertical Track
- C6. Right Hand Vertical Track

## D. TORQUEMASTER PLUS® SPRING ASSEMBLY:

- D1. Center Bracket Bushing Assembly
- D2. TorqueMaster® Spring Tube (Single Or Double Springs) (Purchased separately)
- D3. Left Hand End Bracket (Double Springs Only)
- D4. Right Hand End Bracket (Disconnect Cable Guide)
- D5. Left Hand Cable Drum Assembly
- D6. Right Hand Cable Drum Assembly
- D7. Idler bracket (Single Spring Only) (Purchased separately)
- D8. Left Hand And Right Hand Drum Wraps (Optional)

## E. EXISTING REAR BACK HANGS:

- E1. Left Hand Rear Back Hang Assemblies
- E2. Right Hand Rear Back Hang Assemblies

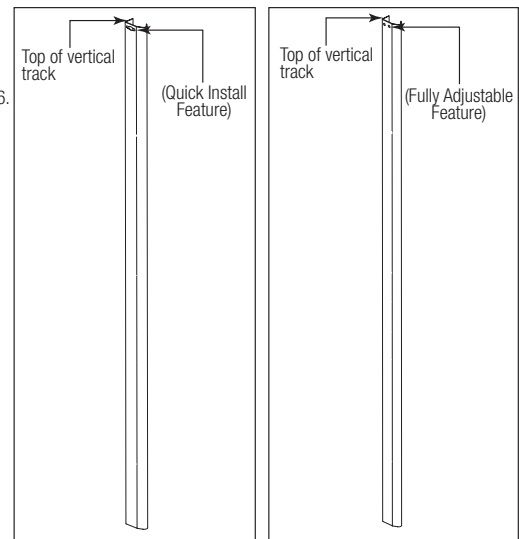

# INSTALLATION

Before installing your door, be certain that you have read and followed all of the instructions covered in the pre-installation section of this manual. Failure to do so may result in an improperly installed door.

**NOTE:** Reference TDS 160 for general garage door terminology at [www.dasma.com](http://www.dasma.com).

## Removing Old TorqueMaster® One Counterbalance System

### 1 Unwinding Old TorqueMaster® Spring(s)

A TorqueMaster® spring system can be identified by the end brackets.

**FOR SINGLE SPRING APPLICATIONS:** The right hand end bracket will always have a drive gear, counter gear, counter cover, and a winding bolt head. The left hand end bracket will have no gears, counter cover, or winding bolt head. The hole for the winding bolt head will be plugged.

**FOR DOUBLE SPRINGS APPLICATIONS:** Both the right hand and left hand end brackets will always have a drive gear, counter gear, counter cover and a winding bolt head.

**IMPORTANT:** RIGHT HAND AND LEFT HAND IS ALWAYS DETERMINED FROM INSIDE THE BUILDING LOOKING OUT.

**FIRST IDENTIFY WHICH COUNTER COVER YOU HAVE:**

If you have a black counter cover: Place a mark on the drive gear tooth and an adjacent mark on the right hand end bracket. Loosen the lock nut 1/4 turn using a 7/16" wrench.

If you have a gray counter cover: Loosen the lock nut 1/4 turn using a 7/16" wrench.

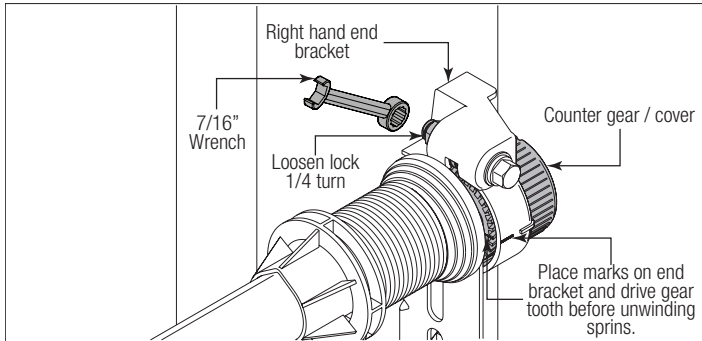

Using an electric drill (High torque / gear reduced to 1300 rpm preferred) with a 7/16" hex head driver, unwind the right hand winding bolt head counterclockwise and count the number of turns the mark on the drive gear passes the adjacent mark on the end bracket. Reference the **winding spring turn** chart below, by door height. Stop unwinding the spring once the counted turns have reached the listed number of turns.

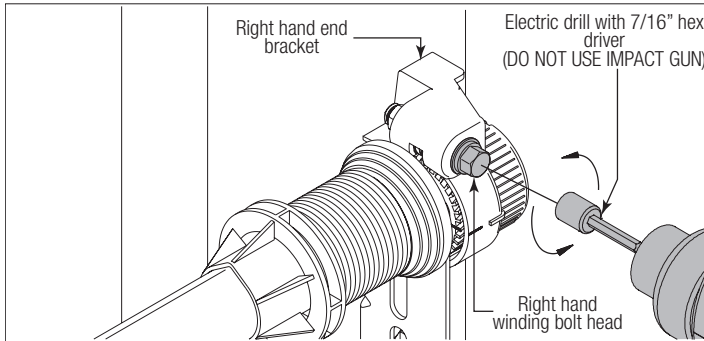

### WINDING SPRING TURN CHART

7'-0"	16
7'-3"	16-1/2
7'-6"	17
7'-9"	17-1/2
8'-0"	18

### CAUTION

DO NOT USE IMPACT GUN TO UNWIND SPRINGS.

**IMPORTANT:** DO NOT REFERENCE THE COUNTER COVER WHEN COUNTING THE NUMBER OF TURNS BEING UNWOUND ON THE SPRING, BUT FOLLOW THE INSTRUCTIONS ABOVE.

Verify that spring tension has been released by pulling the counterbalance lift cable on the right hand cable drum away from the header. If spring tension has been released, the counterbalance lift cable will be loose. In addition, the TorqueMaster® spring tube should be free to rotate in either direction.

If the counterbalance lift cable is still taut and the TorqueMaster® spring tube is difficult to rotate, that is an indication that spring tension still exists on the left hand spring. Repeat this step for releasing spring tension on the left hand side.

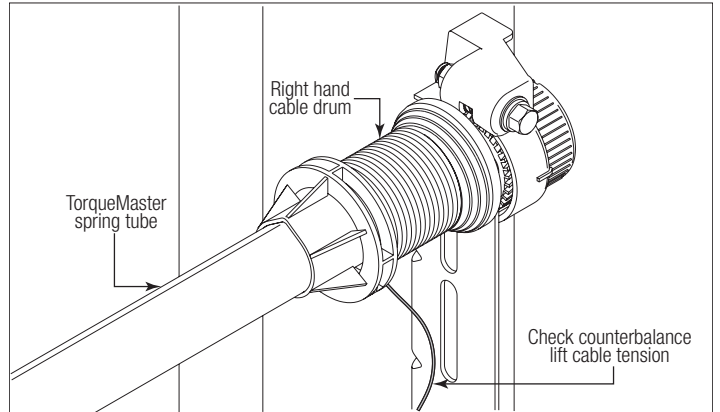

### 2 Removing Old End Brackets

Using a flat tip screwdriver, pry the counter gear and counter cover from the right hand end bracket. Discard the counter gear and counter cover. On double spring applications, repeat for left hand side.

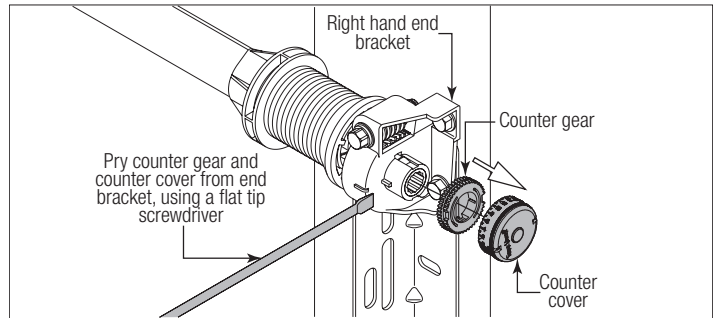

Remove the upper 5/16" x 1-5/8" lag screw from the right hand end bracket. Attach locking pliers to the upper portion of the end bracket and hold the housing steady while removing the lower 5/16" x 1-5/8" lag screw and #10 x 1/2" phillips head screw from the end bracket.

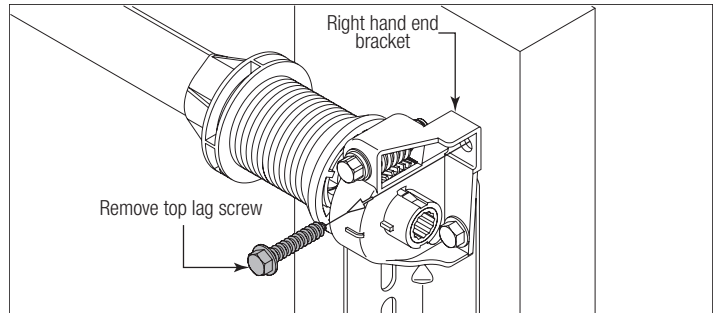

Holding the right hand end bracket steady with locking pliers, carefully pry the end bracket and drive gear off the winding shaft using a flat tip screwdriver.

### WINDING SPRING TURN CHART

DOOR HEIGHT	SPRING TURNS
6'-0"	14
6'-3"	14-1/2
6'-5"	15
6'-6"	15
6'-8"	15-1/2
6'-9"	15-1/2

## CAUTION

THE WINDING SHAFT MAY ROTATE WHEN REMOVING THE END BRACKET AND DRIVE GEAR.

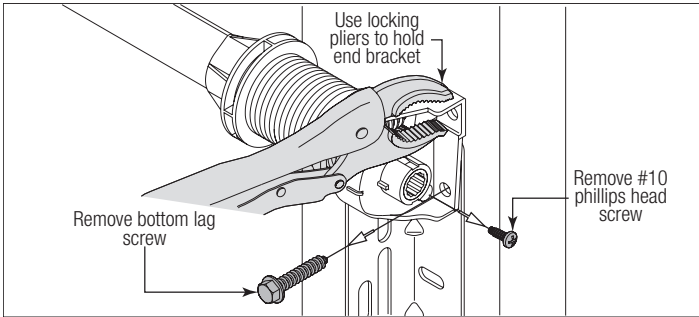

Repeat for the left hand side. Holding the left hand end bracket steady with locking pliers, carefully pry the end bracket off the winding shaft using a flat tip screwdriver.

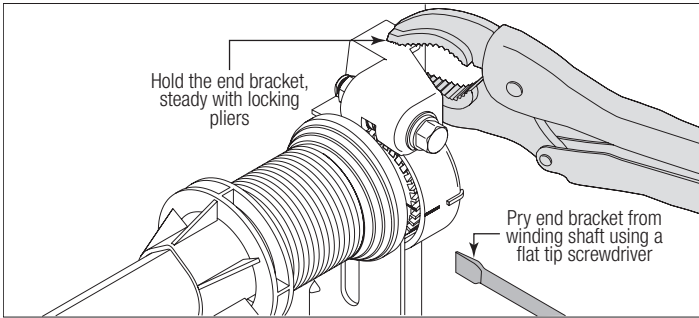

## 3

### Removing Old Cable Drums

Remove the two (2) lag bolts attaching the center bracket assembly to the header board.

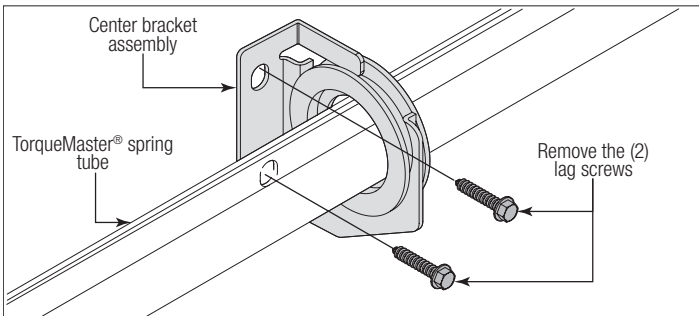

Lift the right hand side of the TorqueMaster® spring tube and slide the cable drum off. Realign the groove in the winding shaft with the round notch in the flag angle and drape the counterbalance lift cable with drum over the flag angle. Lift the left hand side of the TorqueMaster® spring tube and slide the cable drum and winding shaft off. Drape the counterbalance lift cable with drum over the flag angle. Lift the TorqueMaster® spring assembly off the flag angles and out of the doorway. Unhook the counterbalance lift cables from the bottom corner brackets and remove all parts from the work area.

**NOTE:** The cable drums may be difficult to remove. If so, twist the cable drum to aid in removal.

**NOTE:** Single spring applications will have no spring on the left hand side, only a loose winding shaft.

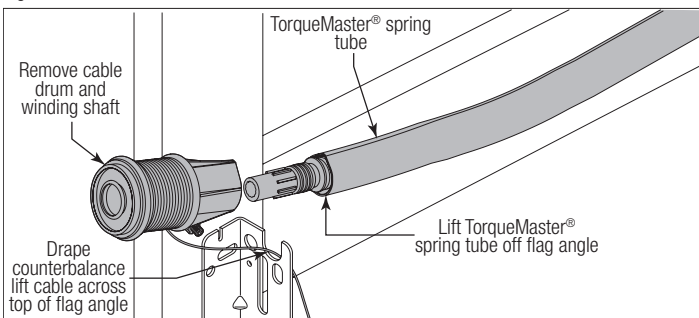

## Inspecting Old Flag Angles

## 4

### Inspecting Old Flag Angles

For 12" Radius, the flag angles must be replaced if the rectangular hole is not present.

For 15" Radius or Low Headroom, the flag angles must be replaced if the length does not match the length in the chart. No need to verify flag angle length for 12"R.

Flag Angle Length For 15" Radius or Low Headroom	
Quick Install Track (Q.I.)	Fully Adjustable Track (F.A.T.)
20.344"	19.946"

**NOTE:** If the flag angles do not need replaced, proceed to Section Installing New TorqueMaster® Plus Counterbalance System.

**NOTE:** If the flag angles will need to be replaced, proceed with the current steps shown below.

## WARNING

**FAILURE TO INSPECT AND RE-PLACE THE OLD FLAG ANGLES, AS STATED IN THIS STEP, WILL CAUSE THE TORQUEMASTER® PLUS COUNTERBALANCE SYSTEM TO BIND AND ALLOW THE DOOR NOT TO OPERATE SMOOTHLY. THIS MAY CAUSE DAMAGE TO THE DOOR, THE DOOR'S COMPONENTS AND CAN CAUSE SEVERE OR FATAL INJURY.**

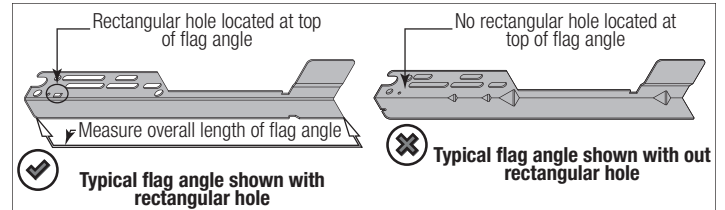

## 5

### Securing Top Section

Having removed the counterbalance system, temporarily secure the top section by driving a nail into the header near the center of the door and bending it over the top section.

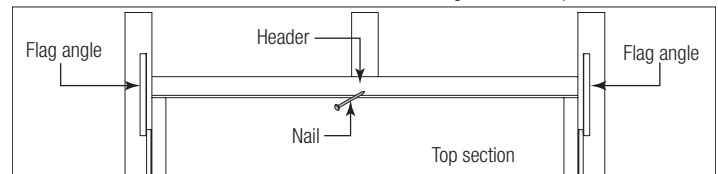

## 6

### Removing Existing Horizontal Tracks

**NOTE:** Horizontal tracks must be removed in order to remove the flag angles.

**NOTE:** Refer to Breakdown Of Parts to determine if you have either Standard Lift or Low Headroom Horizontal Track.

**NOTE:** Depending on your door configuration, it is suggested to keep all of the fasteners after removing the following components. You may or may not have to re-use the fasteners later.

**IF YOU HAVE QUICK INSTALL FLAG ANGLES, COMPLETE THIS STEP:**

With assistance and starting on the left hand side, un-install the rear portion of the horizontal track assembly by removing the 5/16" - 18 x 1 hex bolts and nuts from the rear back hangs.

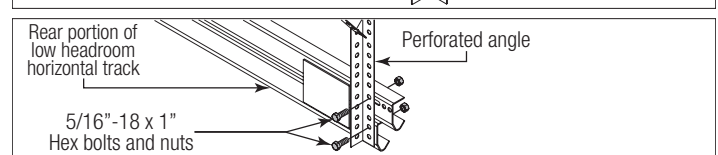
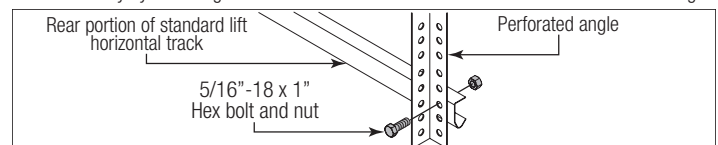

**FOR STANDARD LIFT HORIZONTAL TRACKS:**

Next, un-install the front portion of the horizontal track assembly by removing the (1) 3/8" - 16 x 3/4" truss head bolt and (1) 3/8" - 16 hex nut. Carefully lift the curved end of the horizontal track assembly up and over the top track roller of the top section.

Set the horizontal track assembly and fasteners aside. Repeat the same process for the right hand side.

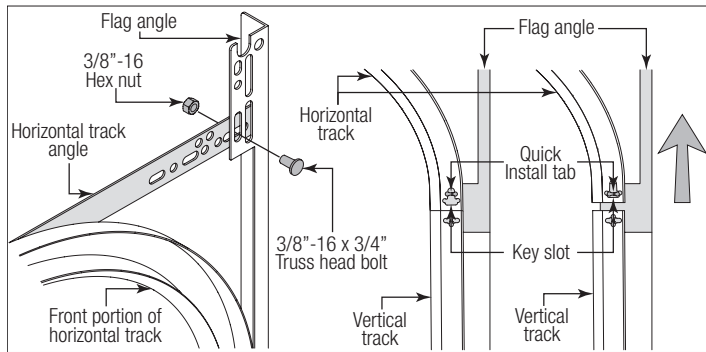

**FOR LOW HEADROOM HORIZONTAL TRACKS:**

Next, un-install the front portion of the horizontal track assembly by removing the (1) 1/4" - 20 x 9/16" track bolt, (1) 1/4" - 20 flange hex nut and the 5/16 washer from the top rail. Carefully lift the top rail of the horizontal track assembly up and over the top track roller of the top section.

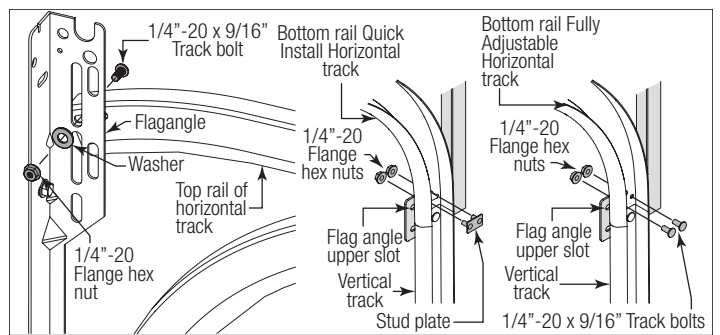
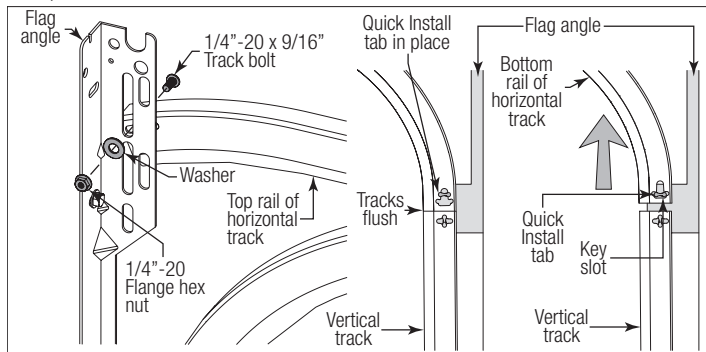

**WARNING**  
**DO NOT RAISE DOOR UNTIL HORIZONTAL TRACKS ARE SECURED AT REAR, AS OUTLINED IN STEP, REAR BACK HANGS, OR DOOR COULD FALL FROM OVERHEAD POSITION CAUSING SEVERE OR FATAL INJURY.**

**7 Removing Old Flag Angles**

**NOTE:** Depending on your door configuration, it is suggested to keep all of the fasteners after removing the following components. You may or may not have to re-use the fasteners later.

Starting on the left hand side, remove the 5/16" x 1-5/8" lag screws, securing the flag angles to the jamb.

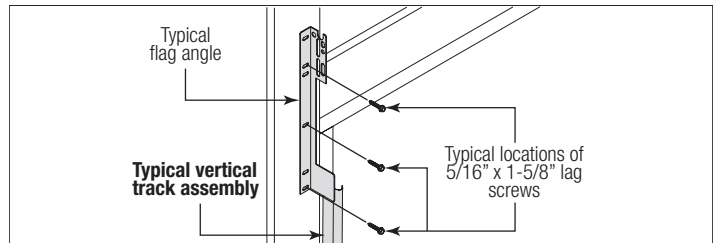

**IF YOU HAVE QUICK INSTALL FLAG ANGLES:**

Rotate the Quick Install flag angle 1/4 turn downward to un-lock it from the vertical track. Remove the lower Quick Install tab from the left hand Quick Install flag angle in the Quick Install feature of the left hand vertical track. Repeat the same process for the right hand side.

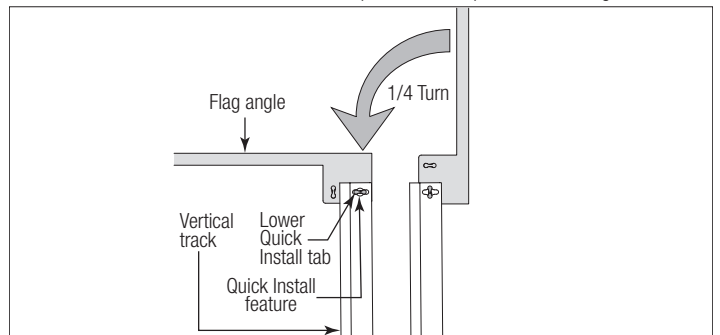

**IF YOU HAVE FULLY ADJUSTABLE FLAG ANGLES:**

If you have Quick Install vertical tracks, remove the stud plate and the (2) 1/4" - 20 flange hex nuts from the left hand flag angle connecting to the left hand vertical track. Repeat for the other side.

If you have Fully Adjustable vertical tracks, remove the (2) 1/4" - 20 x 9/16" track bolts and the (2) 1/4" - 20 flange hex from the left hand flag angle connecting to the left hand vertical track. Repeat the same process for the right hand side.

**WARNING**  
**DO NOT RAISE DOOR UNTIL HORIZONTAL TRACKS ARE RE-SECURED AT REAR, AS OUTLINED IN STEP, REAR BACK HANGS OR DOOR COULD FALL FROM OVERHEAD POSITION CAUSING SEVERE OR FATAL INJURY.**

**IF YOU HAVE FULLY ADJUSTABLE FLAG ANGLES, COMPLETE THIS STEP:**

Un-install the front portion of the horizontal track assembly by removing the (1) 3/8" - 16 x 3/4" truss head bolt and (1) 3/8" - 16 hex nut. Now, un-install the bottom portion of the horizontal track assembly by removing the stud plate or the (2) 1/4" - 20 x 9/16" track bolts and (2) 1/4" - 20 flange hex nuts.

Carefully lift the top rail of the horizontal track assembly up and over the top track roller of the top section.

Set the horizontal track assembly and fasteners aside. Repeat the same process for the right hand side.

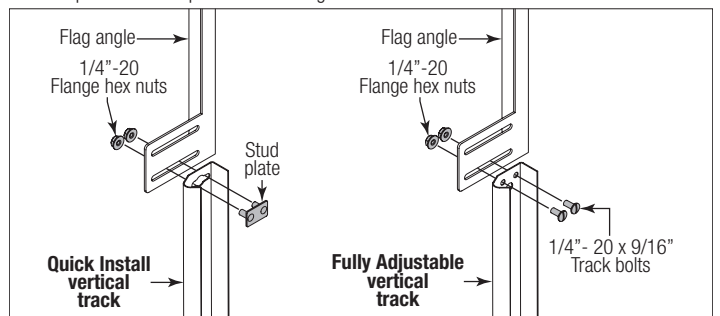
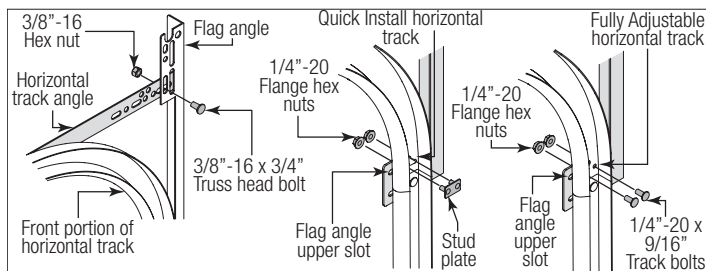

# 8

## Installing New Flag Angles

**NOTE:** Flag angles are right and left handed.

### IF YOU HAVE QUICK INSTALL FLAG ANGLES:

Place the lower Quick Install tab of the left hand flag angle in the Quick Install feature of the left hand Quick Install vertical track. Give the flag angle 1/4 turn to lock in place. Repeat for other side.

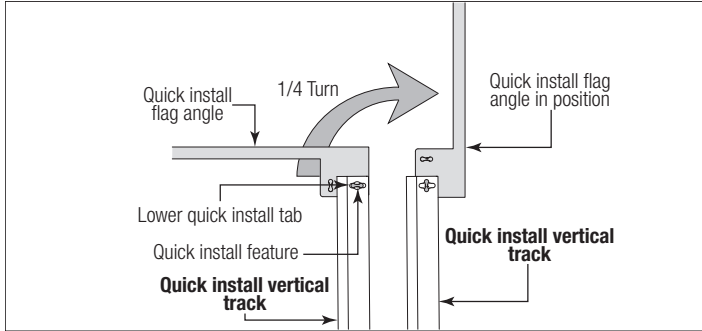

### IF YOU HAVE FULLY ADJUSTABLE FLAG ANGLES:

**NOTE:** Refer to Package Contents / Breakdown of Parts, to determine which Flag Angles / Vertical Tracks you have.

If you have Quick Install vertical tracks:

Hand tighten the left hand flag angle to the left hand vertical track using (1) stud plate and (2) 1/4" - 20 flange hex nuts. Repeat for the other side.

### IF YOU HAVE FULLY ADJUSTABLE VERTICAL TRACKS:

Hand tighten the left hand flag angle to the left hand vertical track using (2) 1/4" - 20 x 9/16" track bolts and (2) 1/4" - 20 flange hex nuts. Repeat for other side. Flange nuts will be secured after flag angle spacing is completed in step, Securing New Flag Angles.

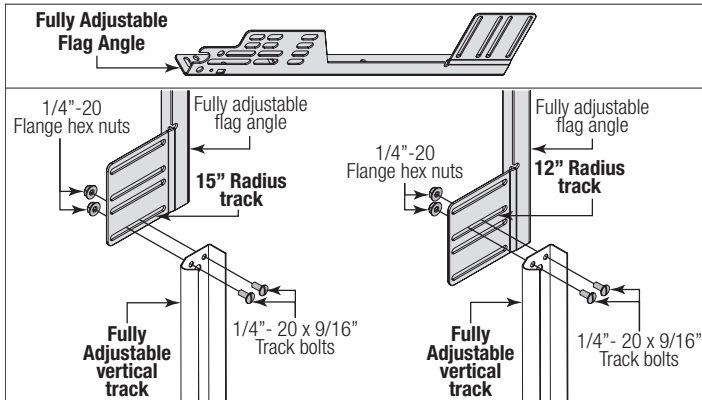
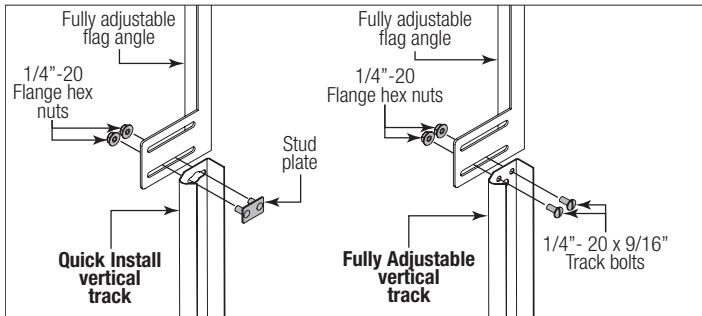

# 9

## Securing New Flag Angles

Vertical track alignment is critical. Position flag angle between 1-11/16" (43 mm) to 1-3/4" (44 mm) from the edge of the door. Flag angles must be parallel to the door sections. Repeat same process for other side.

**IMPORTANT:** THE DIMENSION BETWEEN THE FLAG ANGLES MUST BE DOOR WIDTH PLUS 3-3/8" (86MM) TO 3-1/2" (89 MM) FOR SMOOTH, SAFE DOOR OPERATION.

Complete the flag angle installation by securing the lag screws. Repeat for other side.

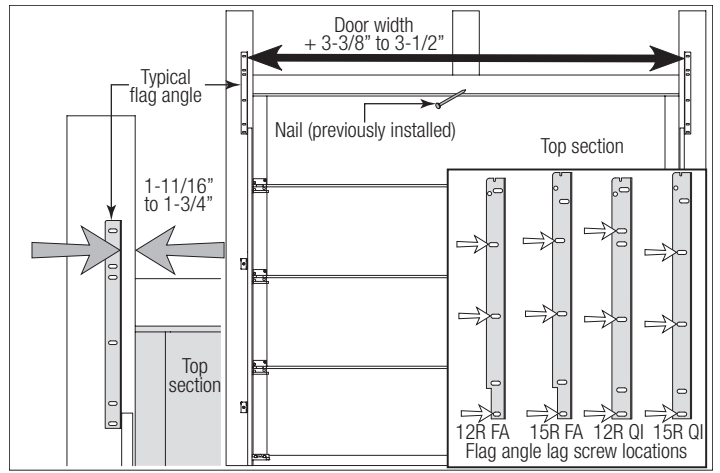

# 10

## Re-Attaching Horizontal Tracks

**NOTE:** If you have Quick Install flag angles, complete this step.

**NOTE:** Refer to Package Contents and or Breakdown Of Parts to determine if you have either Standard Lift Horizontal Tracks, Low Headroom Horizontal Track, Quick Install flag angles or Fully Adjustable flag angles.

### FOR STANDARD LIFT QUICK INSTALL HORIZONTAL TRACK:

To re-install the Quick Install Horizontal Track, place the curved end over the top track roller of the top section. Align the key slot of the Quick Install Horizontal Track with the Quick Install tab of the flag angle. Push the curved portion of Quick Install Horizontal Track downward to lock in place. Level the Quick Install Horizontal Track and bolt the horizontal track angle to the first encountered slot in the flag angle using (1) 3/8" - 16 x 3/4" truss head bolt and (1) 3/8" - 16 hex nut. Repeat for other side.

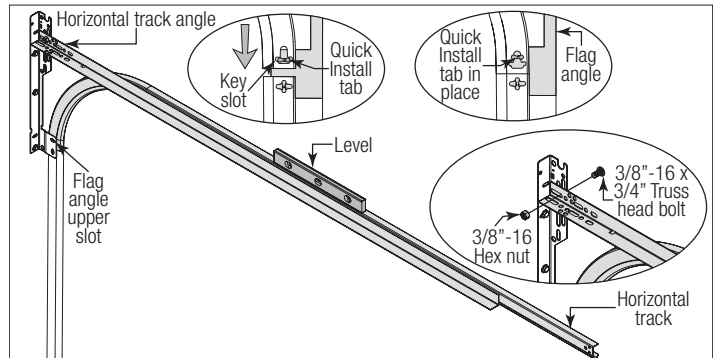

### FOR STANDARD LIFT FULLY ADJUSTABLE HORIZONTAL TRACK:

To re-install Fully Adjustable Horizontal Track, place the top rail over the top track roller of the top section. Align the bottom rail of the Fully Adjustable Horizontal Track with the top of the vertical track. If you have Quick Install horizontal track, tighten the horizontal track to the flag angle with a stud plate and (2) 1/4" - 20 flange hex nuts. If you have Universal Horizontal Track, tighten the Fully Adjustable Horizontal Track to the flag angle with (2) 1/4" - 20 x 9/16" track bolts and (2) 1/4" - 20 flange hex nuts. Level the Fully Adjustable Horizontal Track and bolt the horizontal track angle to the first encountered slot in the flag angle using (1) 3/8" - 16 x 3/4" truss head bolt and (1) 3/8" - 16 hex nut. Repeat for other side.

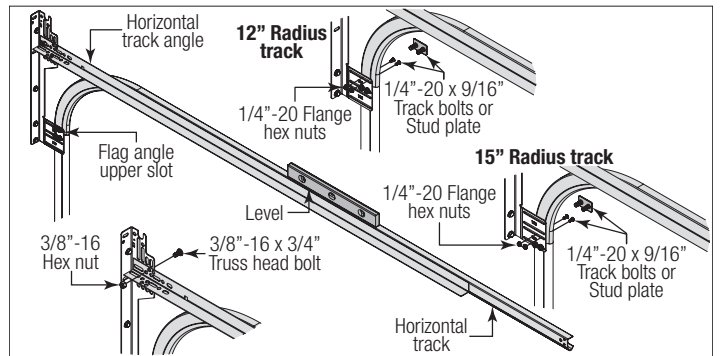

### FOR LOW HEADROOM QUICK INSTALL HORIZONTAL TRACK:

To re-install Low Headroom Quick Install Horizontal Track, place the top rail end over the top track roller of the top section. Align key slot of the bottom rail end of the Low Headroom Quick Install Horizontal Track with the Quick Install tab of the flag angle. Push curved portion of Low Headroom Quick Install Horizontal Track down to lock in place. Level the Low Head-

room Quick Install Horizontal Track and bolt the top rail of the Low Headroom Quick Install Horizontal Track to the encountered slot in the flag angle using (1) 1/4" - 20 x 9/16" track bolt, (1) 1/4" - 20 flange hex nut and (1) 5/16" washer. Repeat for other side.

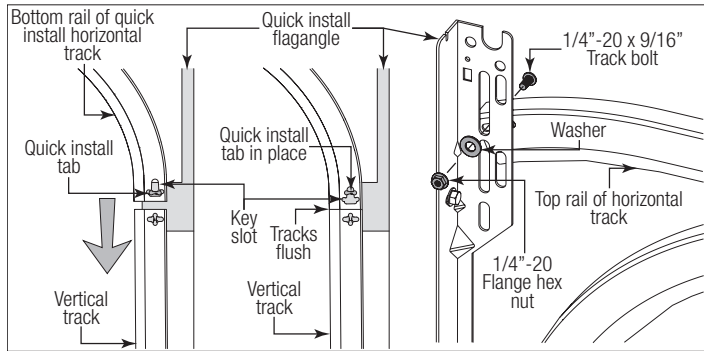

**FOR LOW HEADROOM FULLY ADJUSTABLE HORIZONTAL TRACK:**

To re-install Low Headroom Fully Adjustable Horizontal Track, place the top rail end over the top track roller of the top section. Align the bottom rail end of the Low Headroom Fully Adjustable Horizontal Track with the top of the vertical track. Depending on the door's configuration, either tighten the bottom rail of the horizontal track to the flag angle with (1) stud plate and (2) 1/4" - 20 flange hex nuts or tighten the bottom rail of the horizontal track to the flag angle with (2) 1/4" - 20 x 9/16" track bolts and (2) 1/4" - 20 flange hex nuts. Level the Low Headroom Fully Adjustable Horizontal Track and bolt the top rail of the Low Headroom Fully Adjustable Horizontal Track to the encountered slot in the flag angle using (1) 1/4" - 20 x 9/16" track bolt, (1) 1/4" - 20 flange hex nut and (1) 5/16" washer. Repeat for other side.

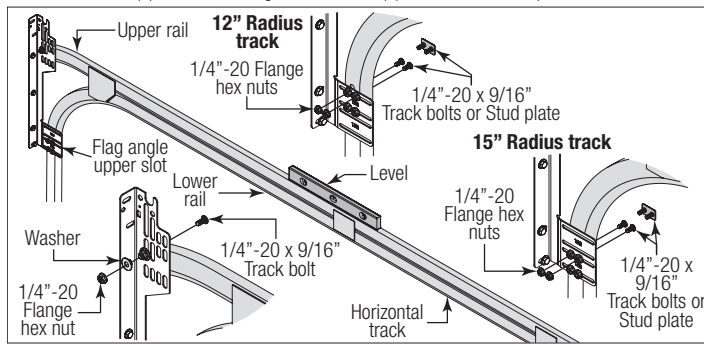

**WARNING**

**DO NOT RAISE DOOR UNTIL HORIZONTAL TRACKS ARE SECURED AT REAR, AS OUTLINED IN STEP, REAR BACK HANGS, OR DOOR COULD FALL FROM OVERHEAD POSITION CAUSING SEVERE OR FATAL INJURY.**

Remove the nail that was temporarily holding the top section in place, installed in step, Securing Top Section.

**IMPORTANT:** FAILURE TO REMOVE NAIL BEFORE ATTEMPTING TO RAISE DOOR COULD CAUSE PERMANENT DAMAGE TO TOP SECTION.

**NOTE:** If an opener will be installed, position horizontal tracks slightly above level.

**Installing New TorqueMaster® Plus Counterbalance System**

**11 Installing New Cable Drum Assemblies**

**NOTE:** Refer to door section identification, located in the pre-installation section of this manual or refer to Breakdown Of Parts.

**NOTE:** Cable drum assemblies are marked right and left hand.

**WARNING**

**FAILURE TO ENSURE TIGHT FIT OF CABLE LOOP OVER MILFORD PIN COULD RESULT IN COUNTERBALANCE LIFT CABLE COMING OFF THE PIN, ALLOWING THE DOOR TO FALL, POSSIBLY RESULTING IN SEVERE OR FATAL INJURY.**

Uncoil the counterbalance lift cables from the cable drum assemblies, making sure you place the left hand cable loop on the left hand milford pin of the bottom corner bracket and the right hand cable loop on the right hand milford pin of the bottom corner bracket. Hang cable drum assemblies over flag angles

**NOTE:** Check to ensure cable loops fits tightly over the milford pins.

**IMPORTANT:** MAKE SURE THE COUNTERBALANCE LIFT CABLE IS LOCATED BETWEEN THE

**TRACK ROLLERS AND THE DOOR JAMB.**

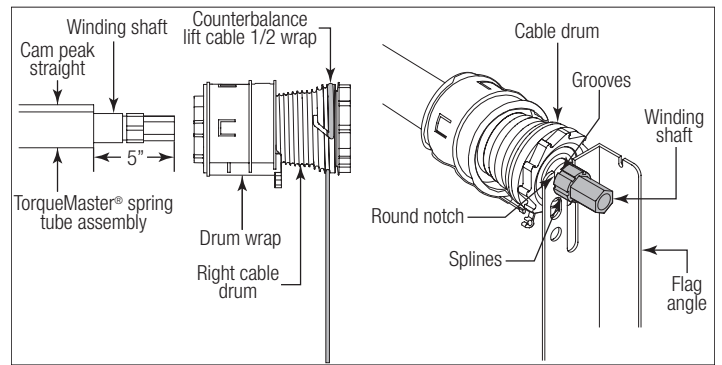

**12 Installing New TorqueMaster® Plus Springs**

TorqueMaster® springs come lubricated and pre-assembled inside the TorqueMaster® spring tube. To prepare for install, lay the spring tube assembly on the floor, inside garage, in front of the door, and with the labeled end to the left. Next, remove the shipping boots from the ends of the TorqueMaster® spring tube.

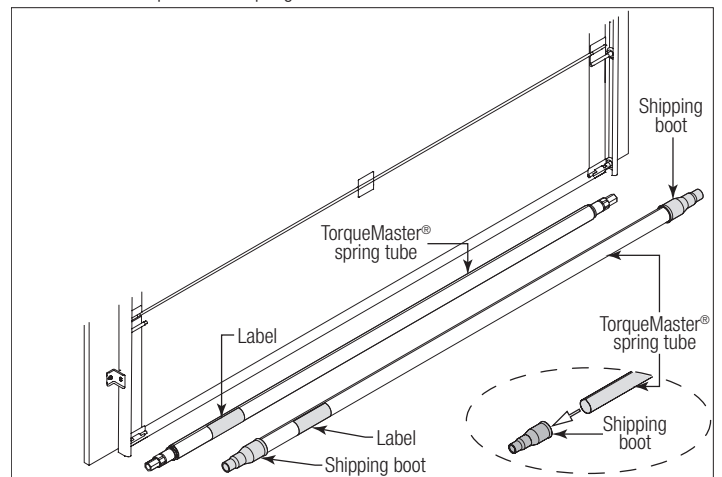

**NOTE:** If your TorqueMaster® springs did not come pre-assembled inside the TorqueMaster® spring tube, then follow these instructions.

Each TorqueMaster® spring is identified as to right hand and left hand. Either located on the perch or by the color coding on the winding shaft. A winding shaft color coded red installs on the left hand side. If there is no color coding, then it installs on the right.

Slide the TorqueMaster® springs, perch end first, into the TorqueMaster® spring tube.

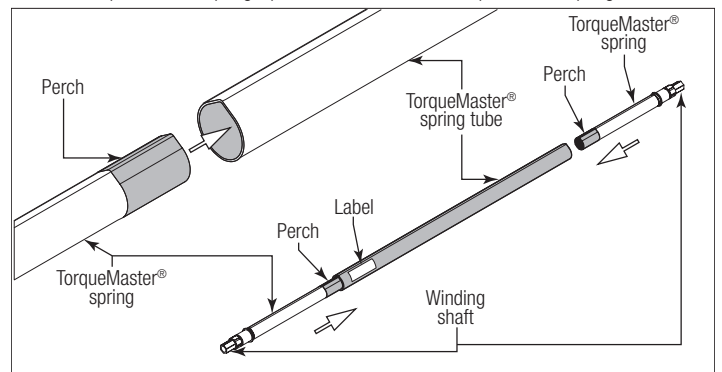

**13 Install New Center Bracket Bushing Assembly**

Tools Required: Step ladder, Safety glasses, Leather gloves

Being cam shaped, the center bushing only fits one way. Slide the center bracket bushing assembly towards the center of the TorqueMaster® spring tube, from the right side, as shown.



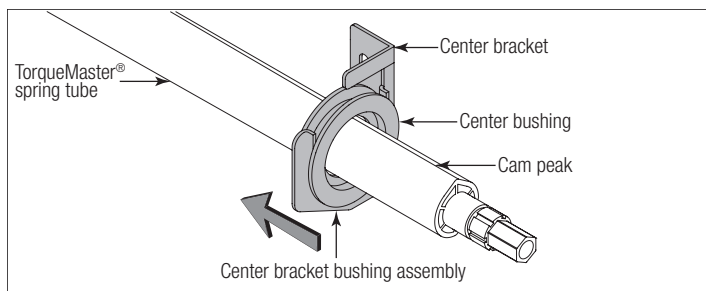

## 14 Drum Wraps (Optional)

**NOTE:** If you don't have drum wraps (optional), then skip this step. Refer to Package Contents / Breakdown Of Parts, to determine if you have drum wraps.

Drum wraps are marked right and left hand. Beginning with the left hand side, slide the left hand drum wrap onto the TorqueMaster® spring tube. Repeat for the right hand side. The drum wrap will be secured later, in Step, Securing Drum Wraps.

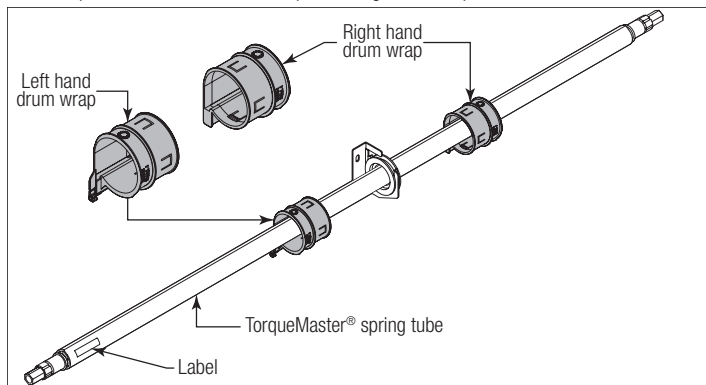

## 15 Installing New Cable Drum Assemblies

Shake the TorqueMaster® spring tube assembly gently to extend the winding shafts out about 5" on each side. For **single spring applications**, there will be no left hand spring in the TorqueMaster® spring tube assembly. Lift the TorqueMaster® spring tube assembly and rest it on top of the flag angles.

**NOTE:** Cable drum assemblies are cam shaped to fit together only one way. TorqueMaster® spring tube assembly are cam shaped to fit together only one way.

Starting on the right hand side, pre-wrap the cable drum with the counterbalance lift cable 1/2 wrap, as shown. Position the TorqueMaster® spring tube assembly so the cam peak is pointing straight up. Slide the cable drum over the winding shaft until the cable drum seats against the TorqueMaster® spring tube assembly. The winding shaft must extend past the cable drum far enough to expose the splines and the grooves. Align the winding shaft grooves with the round notch in the flag angle.

**IMPORTANT:** ENSURE THE COUNTERBALANCE LIFT CABLE HAS 1/2 PRE-WRAP AND IS SEATED IN THE FIRST GROOVE OF THE CABLE DRUM.

**FOR DOUBLE SPRING APPLICATIONS:** Repeat for left hand side.

**FOR SINGLE SPRING APPLICATIONS:** Insert the idler bracket into the left hand cable drum. Lightly press the idler bracket into the cable drum until two distinct clicks are heard, or the bracket is inserted all the way.

**IMPORTANT:** ENSURE THE SNAPS ON THE IDLER BRACKET (LEFT HAND SIDE) ARE ENGAGED INTO THE LEFT HAND CABLE DRUM, SO THAT IT DOES NOT COME BACK OUT.

**NOTE:** The idler bracket is designed for permanent assembly. Do not attempt to remove idler bracket once inserted into the cable drum.

Pre-wrap the left hand cable drum with the counterbalance lift cable 1/2 wrap and slide the cable drum over the TorqueMaster® spring tube assembly. Slide the TorqueMaster® spring tube assembly into the cable drum until the cable drum seats up against the TorqueMaster® spring tube assembly.

**NOTE:** The idler bracket must extend past the cable drum far enough to expose the groove.

Align the idler bracket groove with the round notch in the flag angle.

**IMPORTANT:** ENSURE THE COUNTERBALANCE LIFT CABLE HAS 1/2 PRE-WRAP AND IS SEATED IN THE FIRST GROOVE OF THE CABLE DRUM.

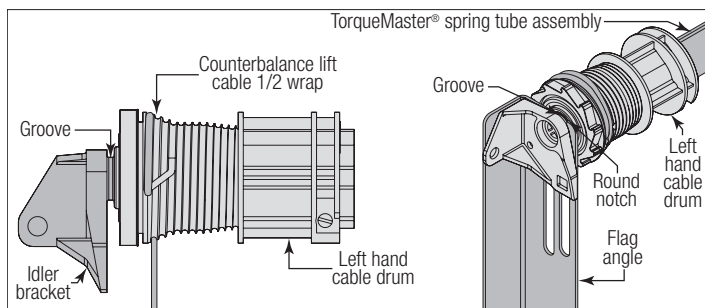
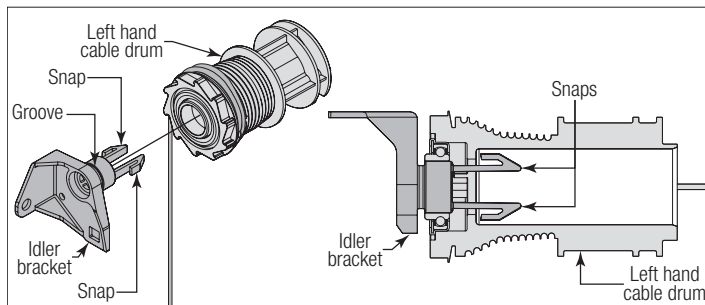
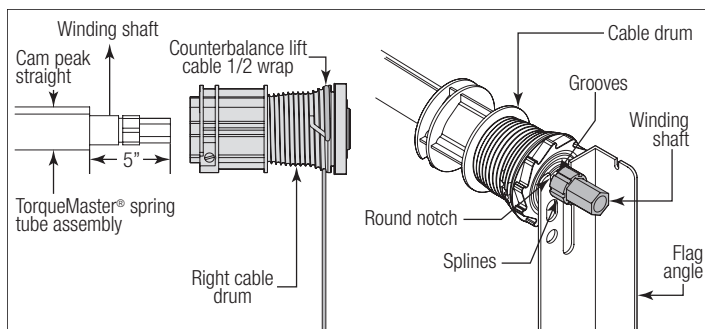

## 16 Install New End Brackets

**IMPORTANT:** WARNING TAGS MUST BE SECURELY ATTACHED TO END BRACKET(S).

**NOTE:** On single spring applications, the idler end bracket was positioned in a previous step, but must be fastened in this step.

**NOTE:** Prior to fastening the end bracket(s) / idler end bracket into the door jamb, pilot drill using a 3/16" drill bit.

Beginning with the right hand side, slide the end bracket onto the winding shaft so that the splines in the ratchet wheel fit onto the winding shaft grooves. Attach the end bracket to the flag angle using (1) 5/16" - 18 x 3/4" carriage bolt, (1) 5/16" washer and (1) 5/16" - 18 hex nut. Then secure the end bracket to the jamb using (1) 5/16" x 1-5/8" lag screw.

**NOTE:** If ratchet wheel falls out of end bracket, refer to illustration for proper insertion orientation.

**FOR DOUBLE SPRING APPLICATIONS:** Repeat same process for left hand end bracket.

**FOR SINGLE SPRING APPLICATIONS:** Secure the idler bracket to the flag angle using (1) 5/16" - 18 x 3/4" carriage bolt, (1) 5/16" washer and (1) 5/16" - 18 hex nut. Then secure the idler bracket to the jamb using (1) 5/16" x 1-5/8" lag screw.

**IMPORTANT:** FOR SINGLE SPRING DOORS, ENSURE THE LEFT HAND CABLE DRUM BEARING IS ALL THE WAY TO THE LEFT AND UP AGAINST THE FLAG ANGLE. IF THE CABLE DRUM IS PULLED AWAY FROM THE FLAG ANGLE, THEN THE IDLER BRACKET CAN RUB AGAINST THE CABLE DRUM CAUSING NOISE.

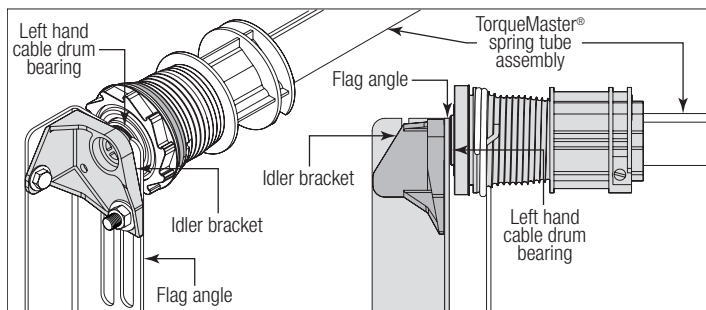
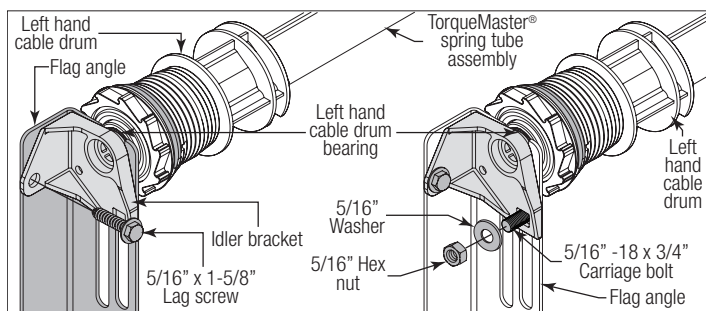
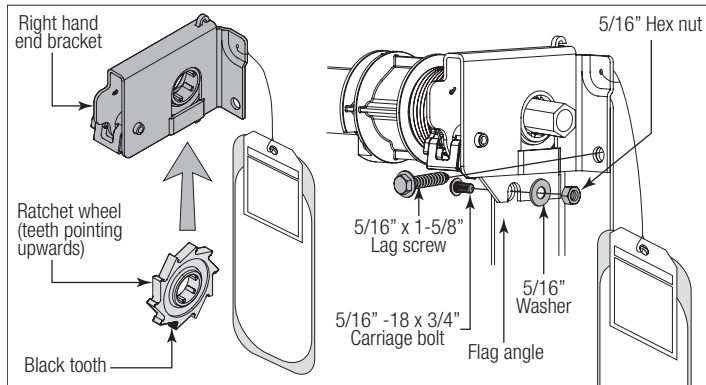
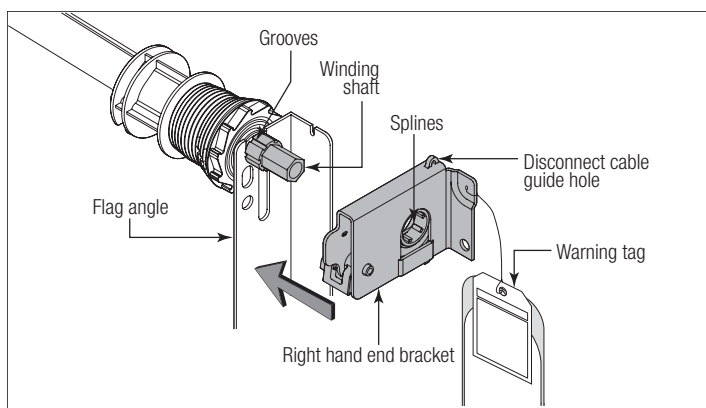

**FOR SINGLE SPRING APPLICATIONS AND YOU DON'T HAVE AN IDLER BRACKET:** An alternative is to discard the left hand gear and use a loose winding shaft in place of the idler bracket. Insert the loose winding shaft into the cable drum, prior to sliding the cable drum over the TorqueMaster® spring tube assembly.

**NOTE:** Take care in handling the loose winding shaft (left hand side), so that it does not slide back into the TorqueMaster® spring tube assembly.

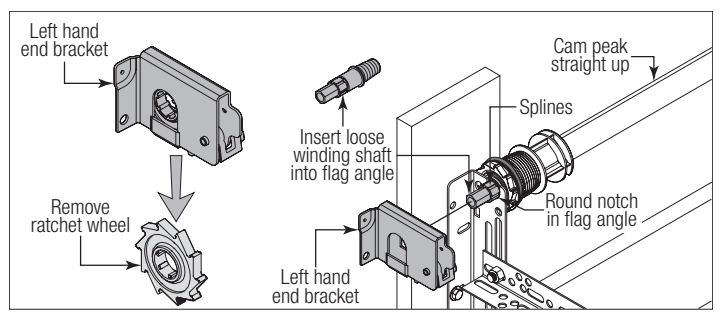

## 17 Securing Center Bracket Bushing Assembly

**IMPORTANT:** TORQUEMASTER® SPRING TUBE MUST BE LEVEL BEFORE SECURING CENTER BRACKET BUSHING ASSEMBLY TO HEADER.

To locate the center bracket bushing assembly, mark the header halfway between the flag angles and level the TorqueMaster® spring tube. Drill 3/16" pilot holes into header for the lag screws. Fasten the center bracket bushing assembly to the header using (2) 5/16" x 1-5/8" lag screws.

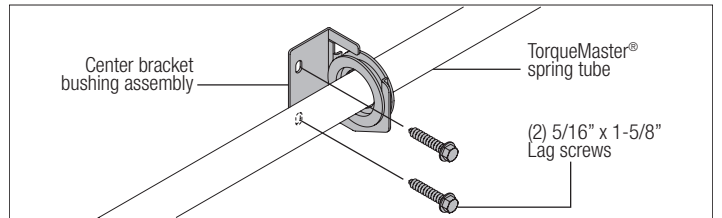

## 18 Securing Door For Winding Spring(s)

With the door in the fully closed position, place vice clamps onto both vertical tracks just above the third track roller. This is to prevent the garage door from rising while winding springs.

**WARNING**  
FAILURE TO PLACE VICE CLAMPS ONTO VERTICAL TRACK CAN ALLOW DOOR TO RAISE AND CAUSE SEVERE OR FATAL INJURY.

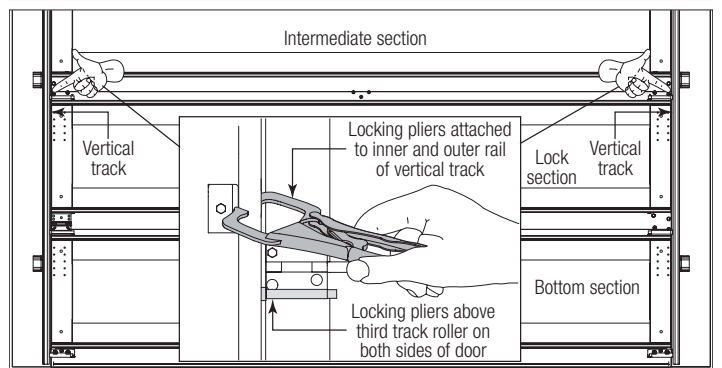

## 19 Lift Cable Adjustments

Starting on the right side, adjust the cable drum assembly by rotating the drum until the set screw faces directly away from the header. The position of the cam peak on the TorqueMaster® spring tube should be pointing straight up.

Loosen the set screw no more than 1/2 turn. Ensure counterbalance lift cable is aligned and seated in the first and second grooves of the cable drum. Pull on the end of the cable to remove all cable slack.

Snug the set screw and then tighten an additional 1-1/2 turns. Measure approximately 6" of cable and cut off excess cable. Insert end of the cable into the hole of cable drum. Repeat for left hand cable drum assembly.

**IMPORTANT:** ENSURE THE COUNTERBALANCE LIFT CABLE IS SEATED IN THE FIRST GROOVE OF THE CABLE DRUM PRIOR TO WINDING SPRINGS.

**NOTE:** Illustration shows the right hand cable drum assembly.

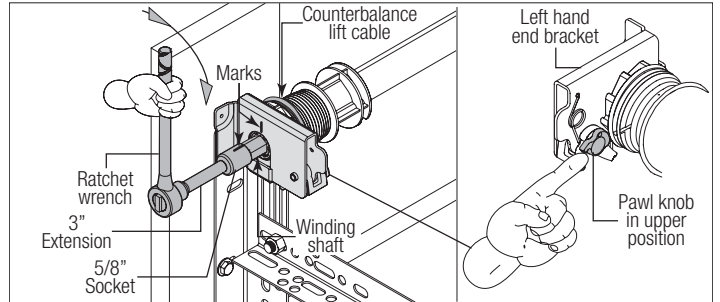
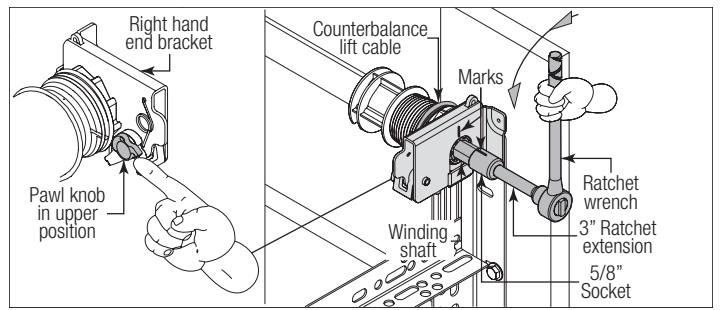
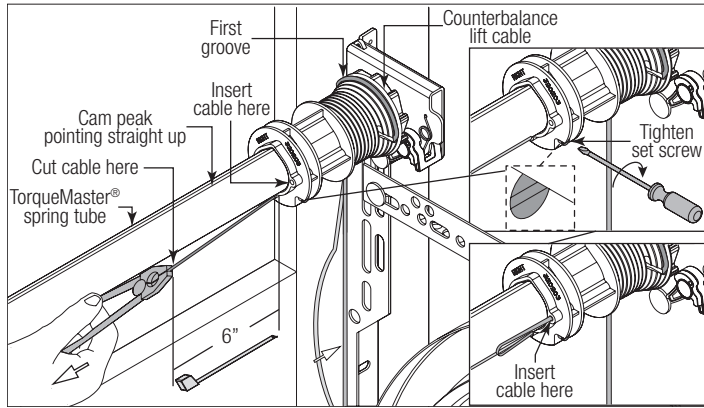

**WINDING SPRING TURN CHART**

DOOR HEIGHT	SPRING TURNS
6'-0"	14
6'-3"	14-1/2
6'-5"	15
6'-6"	15
6'-8"	15-1/2
6'-9"	15-1/2
7'-0"	16
7'-3"	16-1/2
7'-6"	17
7'-9"	17-1/2
8'-0"	18

## 20 Winding Spring(s)

### WARNING

**WINDING TORSION SPRING(S) IS AN EXTREMELY DANGEROUS PROCEDURE AND SHOULD BE PERFORMED ONLY BY A TRAINED DOOR SYSTEM**

### WARNING

**IT IS RECOMMENDED THAT LEATHER GLOVES BE WORN WHILE WINDING SPRINGS. FAILURE TO WEAR GLOVES MAY CAUSE INJURY TO HANDS.**

Double check to ensure the counterbalance lift cable is aligned in the first and second grooves of the cable drum, see step Lift Cable Adjustments. There are two methods for counting the spring turns as you wind. One method is to identify the black tooth on the ratchet wheel inside of the end bracket. When the wheel makes one revolution and the tooth returns to its starting point, one turn has been made. The other method is to make a mark on the winding shaft (or socket) and end bracket, and count your turns in this manner.

Starting on the right hand side, turn the pawl knob on the end bracket to the upper position. Using a ratchet wrench with a 5/8" socket and a 3" extension, wind the spring by rotating the winding shaft counter clockwise, while watching either the black tooth on the ratchet wheel or the mark on the winding shaft.

**NOTE:** A 3" extension is recommended for added clearance from the horizontal track angle.

**IMPORTANT:** PAWL KNOB MUST BE IN UPPER POSITION TO ADD / REMOVE REQUIRED NUMBER OF SPRING TURNS.

After 2 to 3 turns, remove the ratchet wrench and adjust the counterbalance lift cable on the left side. Ensure counterbalance lift cables are in the first and second grooves of the cable drums, as shown in step Lift Cable Adjustments.

**NOTE:** Single spring applications require no spring winding on the left hand side, but lift cable tension needs to be adjusted.

**IMPORTANT:** COUNTERBALANCE LIFT CABLE TENSION MUST BE EQUAL ON BOTH SIDES PRIOR TO FULLY WINDING SPRINGS.

**See the Winding Spring Turn Chart for the required number of winding turns:**

#### FOR SINGLE SPRING APPLICATIONS:

Return to the right hand end bracket and continue winding the spring to the required number of turns for your door following the double spring instructions below. Place pawl knob in lower position.

#### FOR DOUBLE SPRING APPLICATIONS:

Either use the black tooth on the ratchet wheel for winding reference or place a mark on the winding shaft and end bracket. Place the ratchet wrench with 5/8" socket and a 3" extension onto the left hand winding shaft end. To wind the spring, rotate the winding shaft clockwise, while watching the black tooth on the ratchet wheel or the mark on the winding shaft. Rotate the winding shaft to the required number of winding turns for your door. Then return to the right hand side and wind the right hand spring to the required number of turns. Place pawl knob in lower position on both sides.

**IMPORTANT:** MARK THE NUMBER OF SPRING TURNS ONTO THE END BRACKET WARNING TAG.

**NOTE:** Since total turns to balance door can deviate from winding spring turn chart values by  $\pm 1/2$  turn, adjustments to the recommended number of turns may be required after rear back hangs are installed.

## 21 Securing Drum Wraps (Optional)

Tools Required: Step ladder, Safety glasses, Leather gloves

**NOTE:** If you don't have drum wraps (optional), then skip this step. Refer to Package Contents / Breakdown Of Parts, to determine if you have drum wraps.

Starting on the left hand side, position the left hand drum wrap, as shown. Slide the left hand drum wrap over the cable drum assembly.

**IMPORTANT:** PULL THE COUNTERBALANCE LIFT CABLE AWAY FROM THE HEADER TO CLEAR THE LATCH, WHILE SIMULTANEOUSLY SLIDING THE DRUM WRAP AGAINST THE LAST RIB UNTIL THE THREE CATCHES ENGAGE THE 3RD RIB.

Secure the hinge latch by rotating upward until a distinct snap is felt. Confirm the catch is fully engaged by lightly tugging on it. Repeat the same process for right hand side.

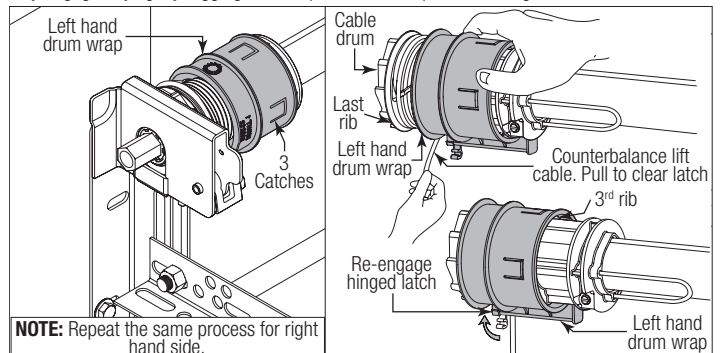

## 22 Re-Secure Rear Back Hangs

**IMPORTANT:** HOLD THE DOOR DOWN TO PREVENT IT FROM RISING UNEXPECTEDLY IN THE

EVENT THE SPRING(S) WAS OVER-WOUND AND CAUTIOUSLY REMOVE VICE CLAMPS FROM VERTICAL TRACKS.

Raise the door until the top section and half of the next section are in the horizontal track radius. Do not raise door any further since rear of horizontal tracks are not yet supported.

## WARNING

**RAISING DOOR FURTHER CAN RESULT IN DOOR FALLING AND CAUSE SEVERE OR FATAL INJURY.**

Clamp a pair of vice clamps onto the vertical tracks just above the second track roller on one side, and just below the second track roller on the other side. This will prevent the door from raising or lowering while installing the rear back hangs.

Attach the horizontal tracks to the rear back hangs with 5/16" - 18 x 1 hex bolts and nuts (may not be supplied). Horizontal tracks must be level and parallel with door within 3/4" to 7/8" maximum of door edge.

**NOTE:** If an iDrive® opener is installed, position horizontal tracks one hole above level when securing it to the rear back hangs.

## WARNING

**KEEP HORIZONTAL TRACKS PARALLEL AND WITHIN 3/4" TO 7/8" MAXIMUM OF DOOR EDGE, OTHERWISE DOOR COULD FALL, RESULTING IN SEVERE OR FATAL INJURY.**

**IMPORTANT:** DO NOT SUPPORT THE WEIGHT OF THE DOOR ON ANY PART OF THE REAR BACK HANGS THAT CANTILEVERS 4" OR MORE BEYOND A SOUND FRAMING MEMBER.

**NOTE:** If rear back hangs are to be installed over drywall, use (2) 5/16" x 2" hex head lag screws and make sure lag screws engage into solid structural lumber.

**NOTE:** 26" angle must be attached to sound framing members and **nails should not be used.**

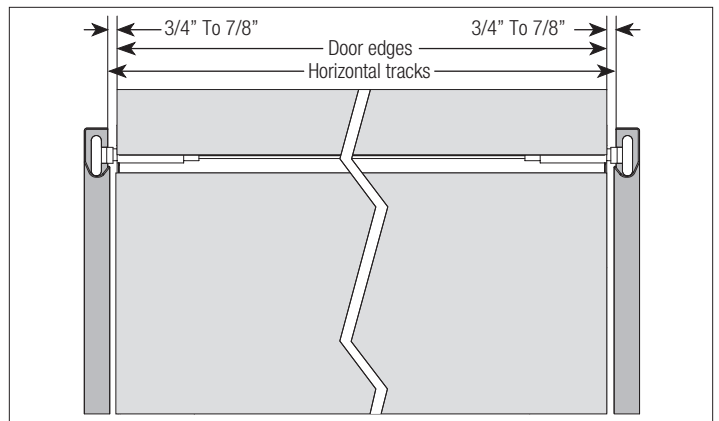

## 23

### Balancing Door

**NOTE:** Windows will cause the top section to be significantly heavier than the remaining sections. Wayne Dalton attempts to balance the door at the top and bottom. To prevent any sudden door acceleration between the top and bottom, we recommend motor operating all doors with windows. Doors with windows in the top section should not be manually operated.

Remove any vice clamps. Lift the door and check its balance. Adjust spring(s) if door lifts by itself (hard to pull down) or if door is difficult to lift (easy to pull down). Anytime spring adjustments are made, ratchet pawl knob must be in the upper position. An unbalanced door can cause TorqueMaster® Plus operation problems.

Close the door and place vice clamps onto both vertical tracks just above the third track roller. This is to prevent the garage door from rising while adjusting the counterbalance spring(s).

**IMPORTANT:** TO ADJUST SPRINGS, ONLY ADD OR REMOVE A MAXIMUM OF 3/10 OF A TURN (THREE TEETH ON THE RATCHET WHEEL) AT A TIME. BOTH SIDES NEED TO BE ADJUSTED EQUALLY ON DOUBLE SPRING DOORS.

**Add spring tension:** The ratchet wheel is made of 10 teeth. To add spring tension, ensure the ratchet and socket is set so that it will tighten counter clockwise on the right hand side and clockwise on the left hand side. Place pawl knob in upper position. Place the ratchet wrench with 5/8" socket and 3" socket extension onto the winding shaft, pull down to add 3/10 of a turn. Watch as three teeth of the ratchet wheel pass over the pawl, creating three "clicks". Place pawl knob in lower position.

**Remove spring tension:** To remove spring tension, place a regular 5/8" wrench onto the winding shaft. Place pawl knob in upper position. Pull down on the wrench to relieve pressure between the pawl and the ratchet wheel. Push in on the pawl to allow the three ratchet wheel teeth to pass by the pawl, as you carefully allow the wrench to be rotated upward by the spring tension, release the pawl to allow it to engage with the ratchet wheel. Place pawl knob in lower position.

**IMPORTANT:** BE PREPARED TO HOLD THE FULL TENSION OF THE SPRING.

**IMPORTANT:** DO NOT ADD OR REMOVE MORE THAN 1 SPRING TURN (1 SPRING TURN EQUALS 10 TEETH ON RATCHET WHEEL) FROM THE RECOMMENDED NUMBER OF TURNS SHOWN ON THE WINDING SPRING TURN CHART.

If the door still does not operate easily, lower the door into the closed position, unwind spring(s) completely, and recheck the following items:

- 1.) Check the door for level.
- 2.) Check the TorqueMaster® spring tube and flag angles for level and plumb.
- 3.) Check the distance between the flag angles, which must be door width plus 3-3/8" to 3-1/2".
- 4.) Check the counterbalance lift cables for equal tension, adjust if necessary.
- 5.) Rewind the spring(s).
- 6.) Make sure door isn't rubbing on jambs.

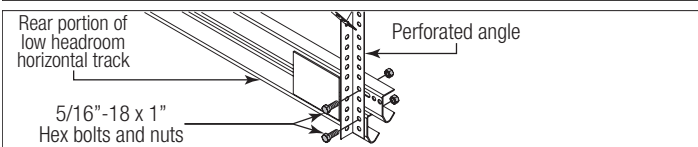
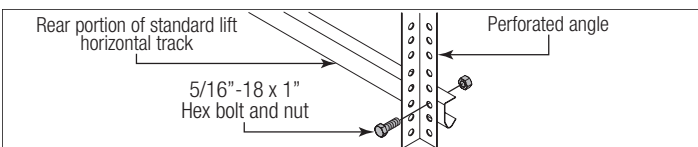
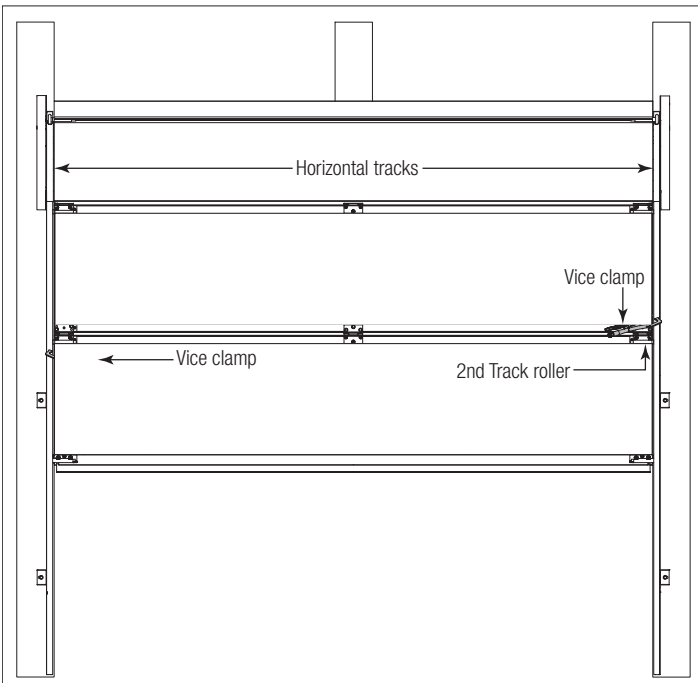
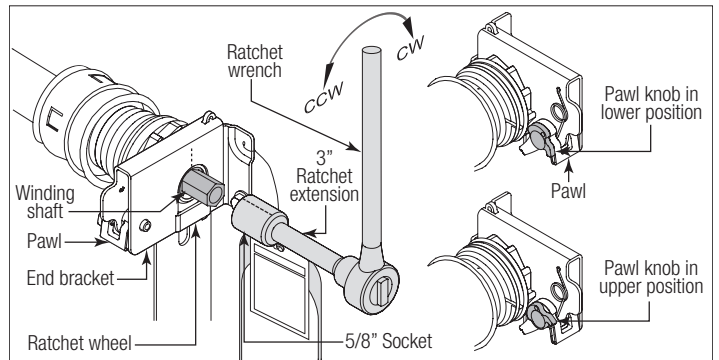

# MAINTENANCE

## Operation And Maintenance

### OPERATING YOUR GARAGE DOOR:

Before you begin, read all warning labels affixed to the door and the installation instructions and owner's manual. When correctly installed, your Wayne Dalton door will operate smoothly. Always operate your door with controlled movements. Do not slam your door or throw your door into the open position, this may cause damage to the door or its components. If your door has an electric opener, refer to the owner's manual to disconnect the opener before performing manual door operation below.

Manual door operation:

For additional information on manual garage door operations go to [www.dasma.com](http://www.dasma.com) and reference TDS 165.

**IMPORTANT:** DO NOT PLACE FINGERS OR HANDS INTO SECTION JOINTS WHEN OPENING AND/OR CLOSING A DOOR. ALWAYS USE LIFT HANDLES / SUITABLE GRIPPING POINTS WHEN OPERATING THE DOOR MANUALLY.

Opening a Door: Make sure the lock(s) are in the unlocked position. Lift the door by using the lift handles / suitable gripping points only. Door should open with little resistance.

Closing a Door: From inside the garage, pull door downward using lift handles / gripping point only or a high friction area only. If you are unable to reach the lift handles/ suitable gripping points only, use pull down rope affixed to the side of door. Door should close completely with little resistance.

Using an electric operator:

**IMPORTANT:** PULL DOWN ROPES MUST BE REMOVED AND LOCKS MUST BE REMOVED OR MADE INOPERATIVE IN THE UNLOCKED POSITION.

When connecting a drawbar (trolley type) garage door operator to this door, an drawbar operator and or drawbar operator bracket must be securely attached to the top section of the door, along with any struts provided with the door. Always use the drawbar operator and or drawbar operator bracket supplied with the door. To avoid possible damage to your door, Wayne Dalton recommends reinforcing the top section on models 8000, 8100, 8200 and 9100 doors with a strut (may or may not be supplied). The installation of the drawbar operator must be according to manufacturer's instructions and force settings must be adjusted properly. Refer to the owner's manual supplied with your drawbar operator for complete details on installation, operation, maintenance and testing of the operator.

Maintaining Your Garage Door:

Before you begin, read all warning labels affixed to the door and the installation instructions and owner's manual. Perform routine maintenance steps once a month, and have the door professionally inspected once a year. Review your Installation Instructions and Owner's Manual for the garage door. These instructions are available at no charge from Wayne Dalton, A Division Of Overhead Door Corporation, P.O. Box 67, Mt. Hope, OH., 44660, or at [www.Wayne-Dalton.com](http://www.Wayne-Dalton.com). For additional information on garage door/operator maintenance go to [www.dasma.com](http://www.dasma.com) and reference TDS 151, 167 and 179.

Monthly Inspections:

1. Visual Inspection: Closely inspect jambs, header and mounting surface. Any wood found not to be structurally sound must be replaced. Inspect the springs, counterbalance lift cables, track rollers, pulleys, rear back hangs and other door hardware for signs of worn or broken parts. Tighten any loose screws and/or bolts. Check exterior surface of the door sections for any minor cracks. Verify door has not shifted right or left in the opening. If you suspect problems, have a trained door system technician make the repairs.

### WARNING

**GARAGE DOOR SPRINGS, COUNTERBALANCE LIFT CABLES, BRACKETS, AND OTHER HARDWARE ATTACHED TO THE SPRINGS ARE UNDER EXTREME TENSION, AND IF HANDLED IMPROPERLY, CAN CAUSE SEVERE OR FATAL INJURY. ONLY A TRAINED DOOR SYSTEMS TECHNICIAN SHOULD ADJUST THEM, BY CAREFULLY FOLLOWING THE MANUFACTURER'S INSTRUCTIONS.**

### WARNING

**NEVER REMOVE, ADJUST, OR LOOSEN THE BOLTS, SCREWS AND/OR LAG SCREWS ON THE COUNTERBALANCE (END OR CENTER BEARING BRACKETS) SYSTEM OR BOTTOM CORNER BRACKETS OF THE DOOR. THESE BRACKETS ARE CONNECTED TO THE SPRING(S) AND ARE UNDER EXTREME TENSION. TO AVOID POSSIBLE SEVERE OR FATAL INJURY, HAVE ANY SUCH WORK PERFORMED BY A TRAINED DOOR SYSTEMS TECHNICIAN USING PROPER TOOLS AND INSTRUCTIONS.**

TorqueMaster® Plus Springs: Pawl knob(s) (located on the TorqueMaster® end brackets above the door) should be engaged to prevent the door from rapidly descending in case of spring failure or forceful manual operation.

2. Door Balance: Periodically test the balance of your door. If you have a garage door drawbar

operator, use the release mechanism so you can operate the door by hand when doing this test. Start with the door in the fully closed position. Lift the door to check its balance. Adjust TorqueMaster®, if door lifts by itself (hard to pull down) or if door is difficult to lift (easy to pull down). DO NOT attempt to repair or adjust TorqueMaster® Springs yourself. To adjust TorqueMaster®, refer to your installation instructions and owner's manual. If in question about any of the procedures, do not perform the work. Instead, have it adjusted by a trained door systems technician.

3. Lubrication: The door should open and close smoothly. Ensure the door track rollers are rotating freely when opening and closing the door. If track rollers do not rotate freely, clean the door tracks, removing dirt and any foreign substances. Clean and lubricate (use a non-silicon based lubricant) graduated end hinges, center hinge(s), steel track rollers, bearings and torsion spring(s) (torsion spring coil surfaces). DO NOT lubricate plastic idler bearings, nylon track rollers, door track. DO NOT oil a cylinder lock, if actuation is difficult use a graphite dust to lubricate.

---

Thank you for your purchase.

---

**PLEASE DO NOT RETURN THIS PRODUCT TO THE STORE**

Please Do Not Return This Product To The Store. Please call 1-866-569-3799 (Press Option 1) and follow the prompts to contact the appropriate customer service agent. They will be happy to handle any questions that you may have.

---

After installation is complete, fasten this manual near garage door for easy reference.