

Models ThermoMark™ 5150 / 5155 / 5200 / 5255

TORSION

COMMERCIAL
STANDARD LIFT

QUICK START GUIDE

Table Of Contents

Pre-Installation	2
Important Safety Instructions	2
Removing an Existing Door and Preparing the Opening	2
Breakdown Of Parts	3
Door Installation Instructions	4
Counterbalance Installation Instructions	7
Maintenance	15
Cleaning Your Garage Door	15
Painting Your Garage Door	16
Operation And Maintenance	16
Warranty	17

PLEASE DO NOT RETURN THIS PRODUCT TO THE STORE

If you need assistance, please call 1-866-569-3799 (press Option 1) and follow the prompts to contact a customer service representative. They will be happy to handle any questions that you may have.

QUICK START GUIDE IMPORTANT NOTICES!

This **Quick Start Guide is only meant to be used as an aid** and / or introduction to garage door installation, and does not replace the complete Installation Instructions and Owner's manual available on the web at www.Wayne-Dalton.com. Wayne Dalton highly recommends that you read and fully understand the Installation Instructions and Owner's Manual before you attempt this installation.

To avoid possible injury, read and fully understand the enclosed instructions carefully before installing and operating the garage door. Pay close attention to all warnings and notes. After installation is complete, fasten this manual near garage door for easy reference.

The complete Installation Instructions and Owner's Manual are available at no charge from:

- Your local Wayne Dalton Sales Center, or
- Online at www.Wayne-Dalton.com, or
- By mailing to: Wayne Dalton, a division of Overhead Door Corporation, P.O. Box 67, Mt. Hope, OH., 44660

Important Safety Instructions

DEFINITION OF KEY WORDS USED IN THIS MANUAL:

WARNING

INDICATES A POTENTIALLY HAZARDOUS SITUATION WHICH, IF NOT AVOIDED, COULD RESULT IN SEVERE OR FATAL INJURY.

CAUTION

PROPERTY DAMAGE OR INJURY CAN RESULT FROM FAILURE TO FOLLOW INSTRUCTIONS.

IMPORTANT: REQUIRED STEP FOR SAFE AND PROPER DOOR OPERATION.

NOTE: Information assuring proper installation of the door.

READ THESE INSTRUCTIONS CAREFULLY BEFORE ATTEMPTING INSTALLATION. IF IN QUESTION ABOUT ANY OF THE PROCEDURES, DO NOT PERFORM THE WORK. INSTEAD, HAVE A TRAINED DOOR SYSTEMS TECHNICIAN DO THE INSTALLATION OR REPAIRS.

1. READ AND FOLLOW ALL INSTALLATION INSTRUCTIONS.
2. Wear protective gloves during installation to avoid possible cuts from sharp metal edges.
3. It is always recommended to wear eye protection when using tools, otherwise eye injury could result.
4. Avoid installing your new door on windy days. Door could fall during the installation causing severe or fatal injury.
5. Doors 12'-0" wide and over should be installed by two persons, to avoid possible injury.
6. Operate door only when it is properly adjusted and free from obstructions.
7. If a door becomes hard to operate, inoperative or is damaged, immediately have necessary adjustments and/ or repairs made by a trained door system technician using proper tools and instructions.
8. DO NOT stand or walk under a moving door, or permit anybody to stand or walk under an electrically operated door.
9. DO NOT place fingers or hands into open section joints when closing a door. Use lift handles/ gripping points when operating door manually.
10. DO NOT permit children to operate garage door or door controls. Severe or fatal injury could result should the child become entrapped between the door and the floor.
11. Due to constant extreme spring tension, do not attempt any adjustment, repair or alteration to any part of the door, especially to springs, spring brackets, bottom corner brackets, fasteners, counterbalance lift cables or supports. To avoid possible severe or fatal injury, have any such work performed by a trained door systems technician using proper tools and instructions.
12. On electrically operated doors, pull down ropes must be removed and locks must be removed or made inoperative in the open (unlocked) position.
13. Top section of door may need to be reinforced when attaching an electric opener. Check door and/ or opener manufacturer's instructions.
14. Visually inspect door and hardware monthly for worn and or broken parts. Check to ensure door operates freely.
15. Test electric opener's safety features monthly, following opener manufacturer's instructions.
16. NEVER hang tools, bicycles, hoses, clothing or anything else from horizontal tracks. Track systems are not intended or designed to support extra weight.
17. This door may not meet the building code wind load requirements in your area. For your safety, you will need to check with your local building official for wind load code requirements and building permit information.
18. For windloaded doors, the wind performance is achieved via the entire door system and component substitution is not authorized without express permission by Wayne Dalton.

NOTE: It is recommended that 5/16" lag screws are pilot drilled using a 3/16" drill bit, prior to fastening.





CAUTION

IF ANY PART OF THE DOOR IS TO BE INSTALLED ONTO PRESERVATIVE-TREATED WOOD, PTFE-COATED OR STAINLESS STEEL FASTENERS MUST BE OBTAINED AND USED. REPLACEMENT FASTENERS MUST BE OF AT LEAST EQUAL STRENGTH AND SIZE AS ORIGINAL FASTENERS. IF THE ORIGINAL FASTENER WAS RED-HEAD, THE REPLACEMENT FASTENER MUST BE RED-HEAD ALSO. CONTACT WAYNE DALTON FOR FASTENER STRENGTH VALUES IF NEEDED.

WARNING

IMPACT GUNS ARE NOT RECOMMENDED. WHEN INSTALLING 5/16" LAG SCREWS USING AN ELECTRIC DRILL/ DRIVER, THE DRILL/ DRIVERS CLUTCH MUST BE SET TO DELIVER NO MORE THAN 200 IN-LBS OF TORQUE. FASTENER FAILURE COULD OCCUR AT HIGHER SETTINGS.

IMPORTANT: RIGHT AND LEFT HAND IS DETERMINED INSIDE THE BUILDING LOOKING OUT.

Potential Hazard	Effect	Prevention
 <p>Moving door</p>	 WARNING Could result in Death or Serious Injury	Keep people clear of opening while Door is moving. Do NOT allow children to play with the Door Opener. Do NOT operate a Door that jams or one that has a broken spring.
 <p>High tension spring</p>	 WARNING Could result in Death or Serious Injury	Do NOT try to remove, install, repair or adjust springs or anything to which door spring parts are fastened, such as, wood blocks, steel brackets, cables or other like items. Installations, repairs and adjustments must be done by a trained door system technician using proper tools and instructions.

Removing an Existing Door and Preparing the Opening

IMPORTANT: COUNTERBALANCE SPRING TENSION MUST ALWAYS BE RELEASED BEFORE ANY ATTEMPT IS MADE TO START REMOVING AN EXISTING DOOR.

WARNING

A POWERFUL SPRING RELEASING ITS ENERGY SUDDENLY CAN CAUSE SEVERE OR FATAL INJURY. TO AVOID INJURY, HAVE A TRAINED DOOR SYSTEMS TECHNICIAN, USING PROPER TOOLS AND INSTRUCTIONS, RELEASE THE SPRING TENSION.

To avoid possible injury and to insure proper installation, it's highly recommended that you read and fully understand the complete instructions on removing an Existing Door & Preparing the Opening. These are available for download at www.Wayne-Dalton.com or at your local Wayne Dalton Sales Center.

WEATHERSTRIPS (MAY NOT BE INCLUDED):

Depending on the size of your door, you may have to cut or trim the weatherstrips (if necessary) to properly fit into the header and jambs.

NOTE: If nailing product at 40°F or below, pre-drilling is required.

NOTE: Do not permanently attach weatherstrips to the header and jambs at this time.

For the header, align the weatherstrip 1/8" to 1/4" inside the header edge, and temporarily secure it to the header with equally spaced nails. Starting at either side of the jamb, fit the weatherstrip up tight against the temporarily attached weatherstrip in the header and 1/8" to 1/4" inside the jamb edge. Temporarily secure the weatherstrip with equally spaced nails. Repeat for other side. This will keep the bottom section from falling out of the opening during installation. Equally space nails approximately 12" to 18" apart.

BREAKDOWN OF PARTS

NOTE: The illustrations shown on this page are general representations of the door parts. Each specific door model may have unique variations.

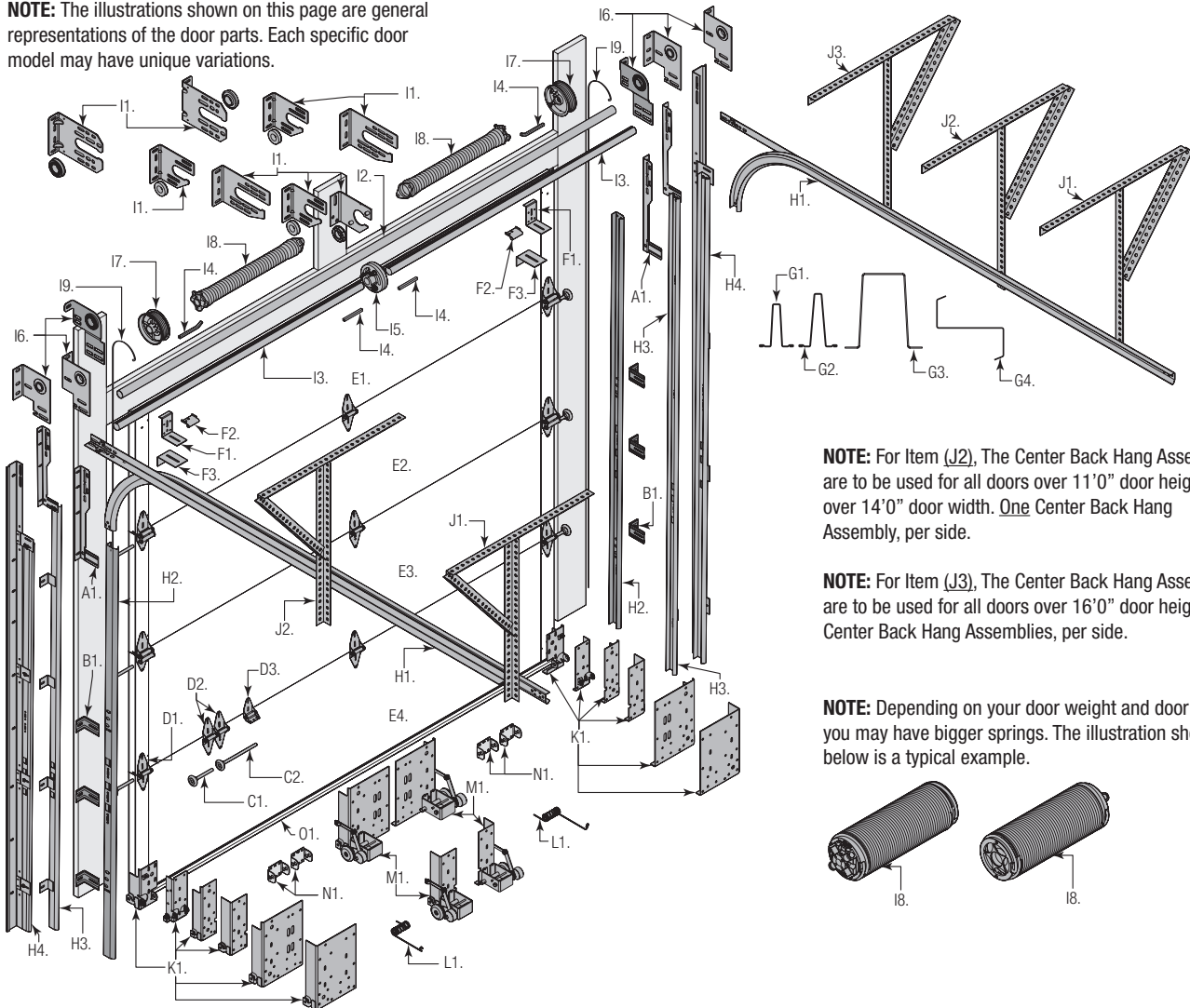

NOTE: For Item (J2), The Center Back Hang Assemblies are to be used for all doors over 11'0" door height and over 14'0" door width. One Center Back Hang Assembly, per side.

NOTE: For Item (J3), The Center Back Hang Assemblies are to be used for all doors over 16'0" door height. Two Center Back Hang Assemblies, per side.

NOTE: Depending on your door weight and door height, you may have bigger springs. The illustration shown below is a typical example.

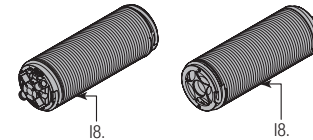

A. FLAG ANGLES (AS REQUIRED):

A1. Fully Adjustable (F.A.) Flag Angles

B. JAMB BRACKETS (AS REQUIRED):

B1. Fully Adjustable (F.A.) Jamb Brackets

C. TRACK ROLLERS (AS REQUIRED):

C1. Short Stem Track Rollers / C2. Long Stem Track Rollers

D. GRADUATED END HINGES:

D1. Single Graduated End Hinges (S.E.H.), Industry Standard
 D2. Double Graduated End Hinges (D.E.H.), Industry Standard
 D3. Half Center Hinges (As Required)

E. STACKED SECTIONS:

E1. Top Section / E2. Intermediate Section (s)
 E3. Lock Section / E4. Bottom Section

F. TOP FIXTURES:

F1. Top Fixture Bases / F2. Top Fixture Slides
 F3. "L" Reinforcing Brackets (As Required)

G. STRUT(S) (AS REQUIRED):

G1. Strut (2" U-shaped) / G2. Strut (3" U-shaped)
 G3. Strut (4") / G4. Girt(s)

H. TRACKS (AS REQUIRED):

H1. Left Hand and Right Hand Horizontal Track Assemblies
 H2. Left Hand and Right Hand Vertical Tracks
 H3. Left Hand and Right Hand Vertical Track Assemblies
 H4. Left Hand and Right Hand Wall Angle Track Assemblies

I. TORSION SPRING ASSEMBLY (AS REQUIRED):

I1. Center Bracket(s) With Center Bracket Bearing(s) (As Required)
 I2. Torsion Shaft / Torsion Keyed Shaft (As Required)
 I3. Torsion Keyed Shafts (As Required)
 I4. Keys (As Required)
 I5. Center Coupler Assembly (As Required)
 I6. Left Hand And Right Hand End Bearing Brackets
 I7. Left Hand And Right Hand Cable Drums
 I8. Left Hand and Right Hand Torsion Springs (As Required)
 I9. Counterbalance Lift Cables

J. REAR BACK HANGS:

J1. Left and Right Hand Rear Back Hangs Assemblies
 J2. Left and Right Hand Rear Center Back Hang Assemblies (As Required)
 J3. Left and Right Hand Rear Center Back Hang Assemblies (As Required)

K. BOTTOM CORNER BRACKETS (AS REQUIRED):

K1. Left Hand and Right Hand Bottom Corner Brackets

L. CABLE KEEPERS (AS REQUIRED):

L1. Cable Keepers

M. BROKEN CABLE SAFETY DEVICES (AS REQUIRED):

M1. Left Hand And Right Hand Broken Cable Safety Devices

N. TRACK ROLLER CARRIER'S (AS REQUIRED):

N1. Track Roller Carrier's

O. BOTTOM WEATHER SEAL:

O1. Bottom Weather Seal (Door Width)

DOOR INSTALLATION INSTRUCTIONS

Before installing your door, be certain that you have read and followed all of the instructions covered in the pre-installation section of this manual. Failure to do so may result in an improperly installed door.

NOTE: Reference TDS 160 for general garage door terminology at www.dasma.com.

IMPORTANT: IF THE DOOR WILL BE EXPOSED TO A SIGNIFICANT AMOUNT OF ROAD SALT, PAINT THE BARE GALVANIZED BOTTOM WEATHER STEEL RETAINER TO INHIBIT RUSTING.

1 Attaching Flag Angles and Jamb Brackets To Vertical Tracks

NOTE: If you have Riveted Track or Angle Mount Track, skip this step.

Hand tighten the left hand flag angle to the left hand vertical track using (2) 1/4" - 20 x 9/16" track bolts and (2) 1/4" - 20 flange hex nuts.

NOTE: The bottom jamb bracket is always the shortest bracket, while the center jamb bracket is the next tallest. If three jamb brackets per side are included with your door, you will have received a top jamb bracket, which is the tallest.

To attach the bottom jamb bracket, locate lower hole of the hole/ slot pattern of the 1st hole set on the vertical track. Align the slot in the jamb bracket with the lower hole of the hole/ slot pattern. Hand tighten jamb bracket using (1) 1/4" - 20 x 9/16" track bolt and (1) 1/4" - 20 flange hex nut. Place the center jamb bracket over the lower hole of the hole/ slot pattern that is centered between the bottom jamb bracket and flag angle of the 2nd hole set. Hand tighten jamb bracket using (1) 1/4" - 20 x 9/16" track bolt and (1) 1/4" - 20 flange hex nut. If a top jamb bracket was included, hand tighten it to vertical track using the lower hole of the hole/ slot pattern in the 3rd hole set and (1) 1/4" - 20 x 9/16" track bolt and (1) 1/4" - 20 flange hex nut. Repeat the same process for right hand side.

2 Attaching Bottom Weather Seal

NOTE: Reference Package Contents or Breakdown Of Parts, to determine if a bottom weather seal was supplied. If a bottom weather seal was supplied, complete this step.

Place the bottom section face down on a couple of sawhorses or flat clean/ smooth surface. Position the bottom weather seal up against the bottom of the bottom section with the long lip on the inside surface of the bottom section. From inside the door, attach the bottom weather seal to the bottom section with 1/4" - 20 x 1 1/16" self drilling screws, placing one 6" in from each end of the bottom section and one every 18" (maximum) in between, as shown.

NOTE: Verify bottom weather seal is aligned with bottom section. If there is more than 1/2" excess weather seal on either side, trim weather seal even with bottom section.

3 Attaching Bottom Corner Brackets

NOTE: Refer to door section identification, located in the pre-installation section of this manual or refer to Breakdown of Parts.

With the bottom section facing down from the previous step, uncoil the counterbalance lift cables.

NOTE: Refer to Package Contents / Breakdown of Parts, to determine which bottom corner brackets you have.

Locate the left hand bottom corner bracket. Secure the cable loop to the clevis pin and bottom corner bracket using a flat washer and a cotter pin. Repeat for right hand bottom corner bracket.

WARNING

ENSURE TIGHT FIT OF CABLE LOOP OVER PIN TO PREVENT COUNTERBALANCE LIFT CABLE FROM COMING OFF THE PIN, WHICH COULD ALLOW THE DOOR TO FALL AND RESULT IN SEVERE OR FATAL INJURY.

NOTE: Prior to installing the bottom corner brackets onto the bottom section, you may have to slit the bottom weather seal at both ends to allow the bottom corner brackets to be adhered to the bottom section unobstructed by the bottom weather seal.

IMPORTANT: DO NOT INSTALL BOTTOM CORNER BRACKETS OVER THE BOTTOM WEATHER SEAL.

Next, align the bottom corner bracket horizontally with the bottom edge of the bottom section and also align the bottom corner bracket vertically with the left bottom edge of the bottom section. Attach the bottom corner bracket to the bottom section using the appropriate 1/4" - 20 x 1 1/16" self drilling screws. Repeat the same process for the right hand side.

NOTE: If you have broken cable safety devices, only install the top (4) 1/4" - 20 x 1 1/16" self drilling screws to secure the bottom corner bracket to the bottom section. Reference Step Broken Cable Safety Devices.

NOTE: If you did not receive Track Roller Carriers or Cable Keepers, then insert a short stem

track roller into each of the bottom corner brackets.

4 Attaching Track Roller Carrier's

NOTE: If you don't have track roller carriers, then skip this step. Refer to Package Contents / Breakdown of Parts, to determine if a track roller carrier was supplied with your door.

NOTE: If your door came with two track roller carriers, then one track roller carrier, short stem track roller and spacer are required for each side.

NOTE: If your door came with four track roller carriers, then two track roller carriers, long stem track roller and spacer are required for each side.

Starting on left hand side of the bottom section, position the track roller carrier with the stamp "STD" facing UP to the bottom corner bracket and aligning the four holes of the track roller carrier with the four holes in the bottom corner bracket. Secure the track roller carrier to the bottom corner bracket with (4) 1/4" - 20 x 7/8" self drilling screws. Repeat the same process for other track roller carrier(s). Insert the appropriate stem track roller and spacer into the inner holes of the track roller carrier(s).

NOTE: The track roller carrier's inner holes are used on doors with 2" track applications; the outer holes are used on doors with 3" track applications.

5 Attaching Cable Keepers

NOTE: If you don't have cable keepers, then skip this step. Refer to Package Contents / Breakdown of Parts, to determine if a cable keeper was supplied with your door.

NOTE: Cable keepers are right hand and left hand.

NOTE: Cable keepers are color coded, black for right hand side and red for left hand side.

Locate the left hand cable keeper. Starting on the left hand side of bottom section, position the left hand cable keeper in between the roller carrier tabs. Insert a short stem track roller with roller spacer through the holes in the tabs and through the cable keeper. Repeat the same process for the right hand side.

6 Attaching Broken Cable Safety Devices

NOTE: If you don't have broken cable safety devices, then skip this step. Refer to Package Contents / Breakdown of Parts, to determine if a broken cable safety device was supplied with your door.

Starting on left hand side of the bottom section, position the left hand broken cable safety device to the bottom corner bracket by aligning the four holes of the bottom corner bracket with the four holes in the broken cable safety device. Secure the broken cable safety device to the bottom corner bracket with (5) 1/4" - 20 x 1 1/16" self drilling screws. Rotate the cam arm upward and slide the counterbalance lift cable through the arm, as shown. Repeat the same process for the right hand side.

7 Attaching Hinges and Struts

NOTE: Refer to the Door Section Identification, Graduated End Hinge Schedule and Strutting Schedule, to determine the appropriate hinges, struts or girts needed to be installed onto your section(s).

NOTE: The graduated hinges can be identified by the number stamped onto their lower hinge leaf. The graduated end hinge sequence is dependent on your track size (2" or 3"). Refer to Graduated End Hinge Schedule.

Section Type	Graduated End Hinge Schedule		
	Graduated End Hinge Number		
	2" Track	3" Track (<= 9 Sections High)	3" Track (> 9 Sections High)
Intermediate X	N/A	N/A	#8
Intermediate IX	N/A	N/A	#8
Intermediate VIII	N/A	N/A	#7
Intermediate VII	#9	N/A	#7
Intermediate VI	#8	#10	#6
Intermediate V	#7	#9	#6
Intermediate IV	#6	#8	#5
Intermediate III	#5	#7	#5
Intermediate II	#4	#6	#4
Intermediate I	#3	#5	#4
Lock	#2	#4	#3
Bottom	#1	#3	#3

NOTE: Strut(s), Girt(s) and hinges must be installed at the same time. The instructions below describe strut(s), girt(s) and hinge installation. However, only install Strut(s) and or girt(s) as indicated in the Strutting Schedule.

NOTE: Refer to the strutting schedules below to determine the placement of strut(s) and girts(s) on your door. Be sure to use the proper schedules for the type of door model and the size of your door.

IMPORTANT: WHEN REFERRING TO THE STRUTTING SCHEDULES, DETERMINE HOW MANY STRUT(S) OR GIRTS(S) YOUR DOOR NEEDS AND ON WHAT SECTIONS THEY ARE NEEDED TO BE INSTALLED. ALSO BE SURE TO USE THE CORRECT STRUTTING SCHEDULE FOR THE PROPER COLOR OF YOUR DOOR.

NOTE: If your door was ordered with the All Windows option, two struts are temporarily factory attached to the section. Both struts are to be permanently fastened during installation.

NOTE: Sections not noted in the strutting schedule, do not require a strut(s) or girts(s). All strut(s) and girts(s) are placed at the top of the section(s).

NOTE: If you paint your door, follow the Strutting Schedule For Brown, Black and Woodgrain Colored Doors.

Strutting Schedule Key:

TS = Top Section	I4 = Intermediate Section #4
I11 = Intermediate Section #11	I3 = Intermediate Section #3
I10 = Intermediate Section #10	I2 = Intermediate Section #2
I9 = Intermediate Section #9	I1 = Intermediate Section #1
I8 = Intermediate Section #8	LS = Lock Section
I7 = Intermediate Section #7	BS = Bottom Section
I6 = Intermediate Section #6	RS = Remaining Sections gets a strut.
I5 = Intermediate Section #5	ES = Every Section Gets A Strut.

For Models 5150 and 5155 - (White, Almond, Taupe Colored Doors)

Door Heights	Section Quantity	Door Widths				
		10'3" - 14'2"	14'3" - 16'2"	16'3" - 18'2"	18'3" - 20'2"	20'3" - 26'2"
6'1"	3	TS	TS, BS	ES	ES, BS	TS, BS
6'1" - 8'1"	4	TS	TS, I1, BS	ES	ES, BS	TS, I1, BS
7'6" - 10'1"	5	TS	TS, I1, BS	ES	ES, BS	TS, I1, BS
9'1" - 12'1"	6	TS	TS, I3, I1, BS	ES	ES, BS	TS, I3, I1, BS
10'6" - 14'1"	7	TS	TS, I3, I1, BS	ES	ES, BS	TS, I3, I1, BS
12'1" - 16'1"	8	TS	TS, I5, I3, I1, BS	ES	ES, BS	TS, I5, I3, I1, BS
13'7" - 18'1"	9	TS	TS, I5, I3, I1, BS	ES	ES, BS	TS, I5, I3, I1, BS
15'1" - 20'1"	10	TS	TS, I7, I5, I3, I1, BS	ES	ES, BS	TS, I7, I5, I3, I1, BS

For Models 5150 and 5155 - (Brown, Black and Woodgrain Colored Doors)

Door Heights	Section Quantity	Door Widths				
		10'3" - 12'2"	12'3" - 16'2"	16'3" - 18'2"	18'3" - 20'2"	20'3" - 26'2"
6'1"	3	TS	ES	ES	ES, BS	TS, BS
6'1" - 8'1"	4	TS	TS, I1, BS	ES	ES, BS	TS, I1, BS
7'6" - 10'1"	5	TS	TS, I1, LS, BS	ES	ES, BS	TS, I1, BS
9'1" - 12'1"	6	TS	TS, I3, I1, BS	ES	ES, BS	TS, I3, I1, BS
10'6" - 14'1"	7	TS	TS, I3, I1, LS, BS	ES	ES, BS	TS, I3, I1, BS
12'1" - 16'1"	8	TS	TS, I3, I1, LS, BS	ES	ES, BS	TS, I5, I3, I1, BS
13'7" - 18'1"	9	TS	TS, I5, I3, I1, LS, BS	ES	ES, BS	TS, I5, I3, I1, BS
15'1" - 20'1"	10	TS	TS, I7, I5, I3, I1, BS	ES	ES, BS	TS, I7, I5, I3, I1, BS

For Models 5200 and 5255 - (White, Almond, Taupe Colored Doors)						
Door Heights	Section Quantity	Door Widths				
		12'3" - 14'2"	14'3" - 16'2"	16'3" - 18'2"	18'3" - 20'2"	20'3" - 26'2"
6'1"	3	TS	TS, BS	ES	ES, BS	TS, BS
6'1" - 8'1"	4	TS	TS, I1, BS	TS, I1, BS	ES, BS	TS, I3, BS
7'6" - 10'1"	5	TS	TS, I1, BS	TS, I1, LS, BS	ES, BS	TS, I3, BS
9'1" - 12'1"	6	TS	TS, I3, I1, BS	TS, I3, I1, BS	ES, BS	TS, I3, I1, BS
10'6" - 14'1"	7	TS	TS, I3, I1, BS	TS, I3, I1, LS, BS	ES, BS	TS, I3, I1, BS
12'1" - 16'1"	8	TS	TS, I5, I3, I1, BS	TS, I5, I3, I1, BS	ES, BS	TS, I5, I3, I1, BS
13'7" - 18'1"	9	TS	TS, I5, I3, I1, BS	TS, I5, I3, I1, LS, BS	ES, BS	TS, I5, I3, I1, BS
15'1" - 20'1"	10	TS	TS, I7, I5, I3, I1, BS	TS, I7, I5, I3, I1, BS	ES, BS	TS, I9, I7, I5, I3, BS

For Models 5200 and 5255 - (Brown, Black and Woodgrain Colored Doors)

Door Heights	Section Quantity	Door Widths				
		10'3" - 12'2"	12'3" - 16'2"	16'3" - 18'2"	18'3" - 20'2"	20'3" - 26'2"
6'1"	3	TS	ES	ES	ES, BS	ES
6'1" - 8'1"	4	TS	TS, I1, BS	TS, I1, BS	ES, BS	ES
7'6" - 10'1"	5	TS	TS, I1, LS, BS	TS, I3, LS, BS	ES, BS	ES
9'1" - 12'1"	6	TS	TS, I3, I1, BS	TS, I5, I3, BS	ES, BS	ES
10'6" - 14'1"	7	TS	TS, I3, I1, LS, BS	TS, I3, I1, LS, BS	ES, BS	ES
12'1" - 16'1"	8	TS	TS, I5, I3, I1, BS	TS, I5, I3, I1, BS	ES, BS	ES
13'7" - 18'1"	9	TS	TS, I5, I3, I1, LS, BS	TS, I5, I3, I1, LS, BS	ES, BS	ES
15'1" - 20'1"	10	TS	TS, I7, I5, I3, I1, BS	TS, I7, I5, I3, I1, BS	ES, BS	ES

Using sawhorses, lay sections together on a flat smooth surface. Ensure the appropriate graduated end hinges, center hinge(s), strut or girt (if applicable) are on top of their corresponding sections.

FOR DOOR MODELS 5150 / 5200:

TO ATTACH GRADUATED END HINGES: Locate the bottom section, the appropriate graduated end hinges for the end stiles. Starting on the left hand side of the bottom section, align the lower hinge leaf of the graduated end hinge over the two punch marks, located at the top of the end stile. Fasten each graduated end hinge to the section using 1/4" - 20 x 7/8" self drilling screws, as shown. Repeat the same process for the right hand side.

TO ATTACH CENTER HINGE(S): Place the lower hinge leaf of the center hinge over the dimples, located at the top of the section. Attach lower hinge leaf to the section using 1/4" - 20 x 7/8" self drilling screws, as shown. Repeat the same process for other center hinge(s).

If applicable and referencing the illustration below, position the strut / girt on the bottom section, as shown. Center the strut / girt side to side on the section. Secure the strut / girt to the section using 1/4" - 20 x 7/8" self drilling screws at each graduated end first then at center hinge locations.

FOR DOOR MODELS 5155 / 5255:

TO ATTACH GRADUATED END HINGES: Locate the bottom section, the appropriate graduated end hinges for the end stiles. Starting on the left hand side of the bottom section, align the lower hinge leaf of the graduated end hinge over the two punch marks, located at the top of the end stile. Fasten each graduated end hinge to the section using 1/4" - 20 x 7/8" self drilling screws, as shown. Repeat the same process for the right hand side.

TO ATTACH CENTER HINGE(S): Place the lower hinge leaf of the center hinge over the dimples, located at the top of the section. Attach lower hinge leaf to the section using 1/4" - 20 x 7/8" self drilling screws, as shown. Repeat the same process for other center hinge(s).

NOTE: If your door came with "L" reinforcing brackets only fasten the top slot of the lower hinge leaf of the center hinge.

If applicable and referencing the illustration below, position the strut / girt on the bottom section, as shown. Center the strut / girt side to side on the section. Secure the strut / girt to the section using 1/4" - 20 x 7/8" self drilling screws at each graduated end first then at center hinge locations.

NOTE: If your door came with "L" reinforcing brackets they must be positioned and installed over the center hinge and fastened to the girt, as shown.

NOTE: Depending on the width of your door, you may have only one center hinge (dimples) marking.

IMPORTANT: ONCE THE 1/4" - 20 X 7/8" SELF DRILLING SCREWS ARE SNUG AGAINST THE LOWER HINGE LEAFS, TIGHTEN AN ADDITIONAL 1/4 TO 1/2 TURN TO RECEIVE MAXIMUM DESIGN HOLDING POWER.

IMPORTANT: PUSH & HOLD THE HINGE LEAF AND OR STRUT SECURELY AGAINST THE SECTION WHILE SECURING WITH THE 1/4" - 20 X 7/8" SELF DRILLING SCREWS. THERE SHOULD BE NO GAP BETWEEN THE HINGE LEAF AND THE SECTION.

Repeat graduated end hinge / center hinge and strut / girt attachment using the appropriate graduated end hinges for all remaining sections, except for the top section.

IMPORTANT: WHEN PLACING TRACK ROLLERS INTO THE #2 GRADUATED END HINGES AND HIGHER, THE TRACK ROLLER GOES INTO HINGE TUBE FURTHEST AWAY FROM SECTION.

8 Attaching Top Fixtures To Top Section

NOTE: Refer to the Door Section Identification and Strutting Schedule (refer to step Attaching Hinges and Strut To Sections), to determine the appropriate struts or girts needed to be installed onto your top section.

NOTE: Strut(s) and or Girt(s) must be installed at the same time. The instructions below describe both strut(s) and girt(s) installation. However, only install Strut(s) and or girt(s) as indicated in the Strutting Schedule (refer to step Attaching Hinges and Strut To Sections).

NOTE: When referring to step Graduated Hinge / Strutting schedules be sure to use the proper schedules for the type of door model and the size of your door.

NOTE: Top Section not noted in the strutting schedule, do not require a strut(s) or girt(s). All strut(s) and girt(s) are placed at the top of the section.

NOTE: Refer to Package Contents / Breakdown Of Parts to determine how many top fixtures came with your door. If your door came with two top fixtures, then one top fixture and a short stem track roller are required for each side. If your door came with four top fixtures, then two top fixtures and a long stem track roller are required for each side.

Loosely secure the top fixture slide and the "L" reinforcement bracket (if applicable) to the top fixture base using (1) 5/16" - 18 x 3/4" carriage bolt and (1) 5/16" - 18 hex nut, as shown. Repeat for other top fixture assembly(s).

Starting on the left hand side of the top section, align the lip of the top fixture base on top of the corner of the top section and even with the edge of the section.

NOTE: If your door is to be trolley operated, it is recommended that an optional strut be installed along the top portion of the top section.

If applicable and referencing the illustration below, position the strut / girt on top of the top fixtures and on the top section, as shown. Center the strut / girt side to side on the section. Secure the strut / girt to the section using 1/4" - 20 x 7/8" self drilling screws at each graduated end first then at center hinge locations, as shown.

NOTE: If your door came with "L" reinforcing brackets they must be positioned and installed under the girt and fastened to the top section, as shown.

Reference the illustrations below, fasten the strut (if applicable), strut clips (if applicable), girt (if applicable) and the top fixture base to the section using the appropriate self drilling screws. Fasten the "L" reinforcement bracket (if applicable) to the section using 1/4" - 20 x 11/16" self drilling screw. Repeat the same process for other top fixture assembly(s). Insert short / long stem track roller into top fixture slide(s).

The top fixture assembly will be tightened and adjusted later, in step, Adjusting Top Fixtures.

9 Attaching Top Head Seal

NOTE: If you don't have a top head seal, then skip this step. Refer to Package Contents / Breakdown of Parts, to determine if you have a top head seal.

Using sawhorses, lay the top section on a flat smooth surface. Position the top head seal on the top section, making sure the straight portion of the head seal is facing the outside of the section and is pointing upward, as shown.

NOTE: Since the top head seal will tend to want to slip off the tongue of the top section prior to securing, it is advisable to have someone hold the top section and another person holding the top head seal in position, while securing it to the top section.

While holding the top head seal in position, use the #6 - 20 x 1/2" screws to secure the head seal to the tongue of the top section, as shown. Screws should be installed at each end and at 18" intervals.

10 Positioning Bottom Section

Center the bottom section in the door opening. Level the section using wooden shims (if necessary) under the bottom section. When the bottom section is leveled, temporarily hold it in place by driving a nail into the jamb and bending it over the edge of the bottom section on both sides.

NOTE: For wider size doors, more than two wooden shims (shown in illustration) might be needed to level the bottom section.

11 Attaching Wall Angle Seals

NOTE: If you don't have wall angle seals, then skip this step. Refer to Package Contents and or illustrations below, to determine which wall angle seals you have received.

Starting with the left hand wall angle, align the profile of the wall angle seal with the inside edge of wall angle. Next, slide wall angle seal over the inside edge of wall angle until seal is flush up against the edge of wall angle, as shown. Repeat the same process for the right hand side wall angle.

12 Attaching Vertical Tracks To Jamb

NOTE: Depending on your door, you may have Fully Adjustable Flag Angles, Riveted Vertical Track Assemblies or you may have Angle Mount Vertical Track Assemblies. Refer to Package Contents / Breakdown of Parts, to determine which Flag Angles / Vertical Track Assemblies you have.

IMPORTANT: IF YOUR DOOR IS TO BE INSTALLED PRIOR TO A FINISHING CONSTRUCTION OF THE BUILDING'S FLOOR, THE VERTICAL TRACKS AND THE DOOR BOTTOM SECTION ASSEMBLY SHOULD BE INSTALLED SUCH THAT WHEN THE FLOOR IS CONSTRUCTED, NO DOOR OR TRACK PARTS ARE TRAPPED IN THE FLOOR CONSTRUCTION.

IMPORTANT: THE TOPS OF THE VERTICAL TRACKS MUST BE LEVEL FROM SIDE TO SIDE. IF THE BOTTOM SECTION WAS SHIMMED TO LEVEL IT, THE VERTICAL TRACK ON THE SHIMMED SIDE MUST BE RAISED THE HEIGHT OF THE SHIM.

NOTE: Make sure the counterbalance lift cable is located between the track rollers and the door jamb.

Starting on the left hand side of the bottom section, remove the nail. Position the left hand vertical track assembly over the track rollers of the bottom section and install, as shown. Drill 3/16" pilot holes into the door jamb for the lag screws.

LOOSELY FASTEN WALL ANGLES TO ONE OF THE FOLLOWING SCENARIOS LISTED BELOW:

Wood jambs, using 5/16" x 1-5/8" lag screws. Drill 3/16" pilot holes into the wood jamb for the lag screws.

Steel jambs, using 5/16" x 1" self drilling screws.

Pre-cast concrete, using 3/8" x 3" sleeve anchor (not supplied).

NOTE: Products being installed to pre-cast or block must use a 3/8" x 3" sleeve anchor to attach the wall angle to the building, as shown. Use the slots in the wall angle as a drill template and drill a 3/8" hole (3-1/2" deep) and secure to anchor.

WARNING DO NOT USE SLEEVE ANCHORS ON HOLLOW BLOCK.

FOR 2" TRACK: Tighten fasteners, securing the bottom jamb bracket in the vertical track assemblies / bottom slot in the wall angle to jamb, maintain 3/8" to 5/8" spacing, between the bottom section and vertical track.

FOR 3" TRACK: Tighten fasteners, securing the bottom jamb bracket in the vertical track assemblies / bottom slot in the wall angle to jamb, maintain 1/2" to 3/4" spacing, between the bottom section and vertical track.

Allow proper clearance as shown and use the values as illustrated in the Side Room Requirements (Minimum Distance Required), located in the pre-installation section of this manual.

Hang counterbalance lift cable over flag angle / angle mount. Repeat same process for other side.

13 Stacking Sections

NOTE: Refer to door section identification, located in the pre-installation section of this manual.

NOTE: The sections can be identified by the installed graduated end hinges. The smallest graduated end hinge on section should be stacked on top of the bottom section, with each end hinge increasing as the sections are stacked, see Breakdown of Parts.

NOTE: Make sure graduated end and center hinges are flipped down, when stacking another section on top.

With assistance, lift second (Lock) section and guide the track rollers into the vertical tracks. Lower section until it is seated against bottom section. Flip hinges up. Fasten center hinge(s) first; then graduated end hinges last using 1/4" - 20 x 7/8" self-drilling screws.

Repeat same process for other sections, except top section.

IMPORTANT: PUSH & HOLD THE UPPER HINGE LEAFS SECURELY AGAINST THE SECTIONS WHILE SECURING WITH 1/4" - 20 X 7/8" SELF-DRILLING SCREWS. THERE SHOULD BE NO GAP BETWEEN THE HINGE LEAFS AND THE SECTIONS.

14 Stacking Top Section

Place the top section in the opening. Install a nail to prevent the top section from falling backwards. Now, flip up the hinge leaves, hold tight against section, and fasten center hinges first and end hinges last (refer to step, Stacking Sections). Vertical track alignment is critical.

POSITION FLAG ANGLE OR ANGLE MOUNT FROM THE EDGE OF THE DOOR:

FOR 2" TRACK APPLICATIONS: 1-11/16" (43 mm) to 1-3/4" (44 mm) for smooth, safe door operation.

FOR 3" TRACK APPLICATIONS: 2-3/16" (56 mm) to 2-1/4" (57 mm) for smooth, safe door operation

Tighten the bottom lag screw. Flag angles / Angle mount must be parallel to the door sections. Repeat for other side.

FOR 2" TRACK APPLICATIONS: Door width plus 3-3/8" (86mm) to 3-1/2" (89 mm) for smooth, safe door operation.

FOR 3" TRACK APPLICATIONS: Door width plus 4-7/8" (124mm) to 5" (127 mm) for smooth, safe door operation.

Complete the vertical track installation by securing the fasteners to the jamb. Push the vertical track against the track rollers so that the track rollers are touching the deepest part of the curved side of the track; tighten all the track bolts and nuts. Repeat for other side.

15 Attaching Drawbar Operator Bracket

NOTE: If you don't have a drawbar operator bracket, then skip this step. Refer to Illustrations shown below, Package Contents or Breakdown of Parts, to determine which drawbar operator bracket you have.

NOTE: If you're installing a drawbar operator, the drawbar operator bracket must be mounted and secured prior to installing top section.

IMPORTANT: WHEN CONNECTING A TROLLEY TYPE GARAGE DOOR OPENER TO THIS DOOR, A WAYNE DALTON OPERATOR / TROLLEY BRACKET MUST BE SECURELY ATTACHED TO THE TOP SECTION OF THE DOOR IF ONE HAS BEEN PROVIDED, ALONG WITH ANY STRUTS PROVIDED WITH THE DOOR (IF A WAYNE DALTON OPERATOR / TROLLEY BRACKET WAS NOT PROVIDED WITH YOUR DOOR, THAN USE THE ONE PROVIDED BY YOUR OPERATOR MANUFACTURER). THE INSTALLATION OF THE OPERATOR MUST BE ACCORDING TO MANUFACTURER'S INSTRUCTIONS AND FORCE SETTINGS MUST BE ADJUSTED PROPERLY.

NOTE: For retro fit applications, the drawbar operator bracket must be aligned with an existing operator.

NOTE: Refer to illustrations to determine which drawbar operator bracket was supplied with your door.

Place the bottom half of drawbar operator bracket inside the top half of drawbar operator bracket and flush against the inside surface of the top section. Adjust both the top and bottom halves out as far apart as possible on the section surface, as shown. Secure the bottom half drawbar operator bracket and the top half drawbar operator bracket together using (4) 5/16" - 18 x 1/2" carriage bolts and (4) 5/16" - 18 flange hex nuts.

NOTE: Install the 5/16" - 18 x 1/2" carriage bolts and the 5/16" - 18 flange hex nuts as far apart as possible, prior to securing both top and bottom halves together.

Now, locate the center of the top section and align the center of the holes in the drawbar operator bracket assembly with the top section center line. Align the drawbar operator bracket assembly vertically.

FOR STANDARD INSTALLATION: Slide the upper half of the drawbar operator bracket under the strut (if applicable), keeping the drawbar operator bracket aligned with the center line. Remove the strut's screws, if necessary and attach to the top section (through strut if necessary) using 1/4" - 20 x 7/8" self drilling screws. Attach the lower half of the drawbar operator bracket to the section surface using 1/4" - 20 x 7/8" self drilling screws.

NOTE: When attaching drawbar operator bracket to top section with strut, apply additional pressure to thread into the strut.

FOR DOOR SECTIONS WITH ALL WINDOWS INSTALLATION: Slide the top half of the drawbar operator bracket assembly under the strut. Slide the bottom half of the drawbar operator bracket assembly under the strut and over the center hinge, keeping the drawbar operator bracket assembly aligned with the center line. Attach the drawbar operator bracket assembly to the top section using 1/4" - 20 x 7/8" self drilling screws and strut clips.

NOTE: If needed, temporarily remove the strut and the upper hinge leaf of the center hinge screws to properly position the drawbar operator bracket assembly onto the top section.

NOTE: Depending on your door width, it may be required that the rectangular drawbar operator bracket be mounted off center so the drawbar operator bracket mounts to the hinge points.

Now, locate the center of the top section and align the drawbar operator bracket assembly with the top section center line. Align the drawbar operator bracket assembly vertically and horizontally. Secure the drawbar operator bracket to the top section surface using 1/4" - 20 x 7/8" self drilling screws, as shown. Next, if applicable and using 1/4" - 20 x 7/8" self drilling screws, secure the rectangular drawbar operator bracket to the Strut / C Channels, as shown.

16 Attaching Horizontal Tracks

NOTE: Depending on your door, you may have Fully Adjustable Flag Angles, Riveted Vertical Track Assemblies or you may have Angle Mount Vertical Track Assemblies. Refer to Package Contents / Breakdown of Parts, to determine which Flag Angles / Vertical Track Assemblies you have.

⚠ WARNING

DO NOT RAISE DOOR UNTIL HORIZONTAL TRACKS ARE SECURED AT REAR, AS OUTLINED IN STEP, REAR BACK HANGS, OR DOOR COULD FALL FROM OVERHEAD POSITION CAUSING SEVERE OR FATAL INJURY.

IMPORTANT: PRIOR TO INSTALLING THE HORIZONTAL TRACKS, USE CABLES OR CHAINS TO TEMPORARILY SUSPEND THE REAR PORTION OF HORIZONTAL TRACKS.

⚠ WARNING

DO NOT USE ROPES, SINCE EDGES OF HORIZONTAL TRACKS AND ANGLES ARE VERY SHARP.

IF YOU HAVE FLAG ANGLES: To install horizontal track, place the curved end over the top track roller of the top section. Align the bottom of the horizontal track with the top of the vertical track. Tighten the horizontal track to the flag angle with (2) 1/4" - 20 x 9/16" track bolts and (2) 1/4" - 20 flange hex nuts.

IF YOU HAVE ANGLE MOUNT: To install horizontal track, place the curved end over the top track roller of the top section. Align the bottom of the horizontal track with the top of the vertical track. Tighten the horizontal track to the angle mount with (2) 1/4" - 20 x 9/16" track bolts and (2) 1/4" - 20 flange hex nuts.

Next level the horizontal track assembly and bolt the horizontal track angle to the first encountered slot in the flag angle / angle mount using (1) 3/8" - 16 x 3/4" truss head bolt and (1) 3/8" - 16 hex nut. Repeat for other side. Remove nail that was temporarily holding the top section in position.

IMPORTANT: FAILURE TO REMOVE NAIL BEFORE ATTEMPTING TO RAISE DOOR COULD CAUSE PERMANENT DAMAGE TO TOP SECTION.

17 Adjusting Top Fixtures

With horizontal tracks installed, you can now adjust the top fixtures. Vertically align the top section of the door with the lower sections. Once aligned, position the top fixture slide, out against the horizontal track. Maintaining the slide's position, tighten the 5/16" - 18 hex nuts to secure the top fixture slide to the top fixture base. Repeat for other side.

Next remove the nail(s) that was temporarily holding the top section in place, installed in step, Top Section.

IMPORTANT: FAILURE TO REMOVE NAIL(S) BEFORE ATTEMPTING TO RAISE DOOR COULD CAUSE PERMANENT DAMAGE TO TOP SECTION.

COUNTERBALANCE INSTALLATION INSTRUCTIONS

18 Attaching End Bearing Brackets

IMPORTANT: RIGHT AND LEFT HAND IS ALWAYS DETERMINED FROM INSIDE THE BUILDING LOOKING OUT.

⚠ WARNING

INSTALL END BEARING BRACKETS TO SOLID STRUCTURAL MEMBERS ONLY. DO NOT INSTALL OVER DRY WALL OR PANELING. FAILURE TO INSTALL END BEARING BRACKETS TO SOLID STRUCTURAL MEMBERS CAN CAUSE SEVERE OR FATAL INJURY.

⚠ WARNING

FAILURE TO USE PROPER NUMBER OF FASTENERS CAN RESULT IN SUDDEN SPRING TENSION RELEASE, CAUSING SEVERE OR FATAL INJURY.

NOTE: Spring pads must be securely anchored before proceeding, as shown. The pads must be flush with the jambs.

IMPORTANT: RIGHT AND LEFT HAND IS ALWAYS DETERMINED FROM INSIDE THE BUILDING LOOKING OUT.

NOTE: Refer to Package Contents / Breakdown of Parts to determine which end bearing bracket you have.

NOTE: End bearing brackets are right hand and left hand.

Attach the left hand end bearing bracket through either the end bearing bracket's upper or lower slots to the left hand horizontal track angle using (2) 3/8" - 16 x 3/4" truss head bolts and (2) 3/8" - 16 nuts.

IMPORTANT: THE END BEARING BRACKET'S LOWER SLOTS ARE USED ON DOORS WITH 12" RADIUS TRACK; THE UPPER SLOTS ARE USED ON DOORS WITH 15" RADIUS TRACK.

SECURE THE END BEARING BRACKET TO THE JAMB USING ONE OF THE FOLLOWING

SCENARIOS LISTED BELOW:

For wood jambs, using 5/16" x 1-5/8" lag screw(s).

NOTE: Prior to fastening end bearing brackets into the door jamb, pilot drill using a 3/16" drill bit.

For steel jambs, using 5/16" x 1" self drilling screw(s).

For pre-cast concrete, using 3/8" x 3" sleeve anchor(s) (not supplied).

NOTE: Products being installed to pre-cast or block must use a 3/8" x 3" sleeve anchor to attach the end bearing brackets to the building, as shown. Use the slots in the end bearing bracket as a drill template and drill a 3/8" hole (3-1/2" deep) and secure to anchor.

WARNING

DO NOT USE SLEEVE ANCHORS ON HOLLOW BLOCK.

Repeat the same process for the right hand side.

NOTE: This illustration shows 12" or 15" radius track with lag screws to Wood Jambs.

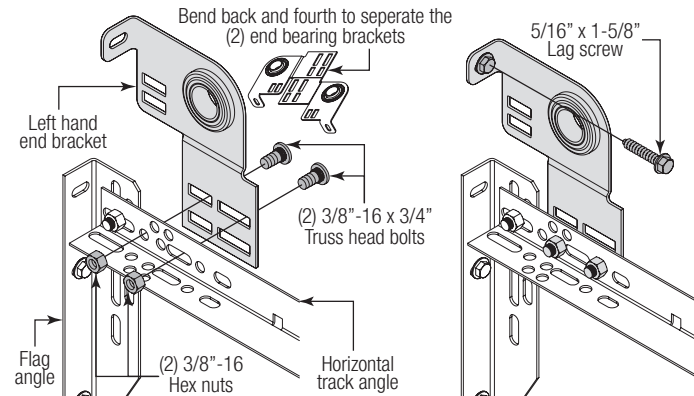

IMPORTANT: THE END BEARING BRACKET'S LOWER SLOTS ARE USED ON DOORS WITH 12" RADIUS TRACK; THE UPPER SLOTS ARE USED ON DOORS WITH 15" RADIUS TRACK.

NOTE: This illustration shows 15" radius track with lag screws to Wood Jambs.

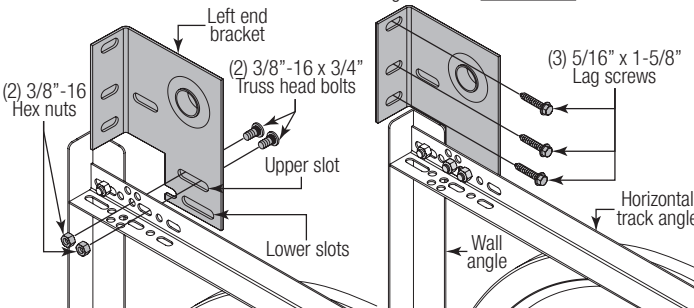

NOTE: This illustration shows 12" or 15" radius track with self drilling screws to Steel.

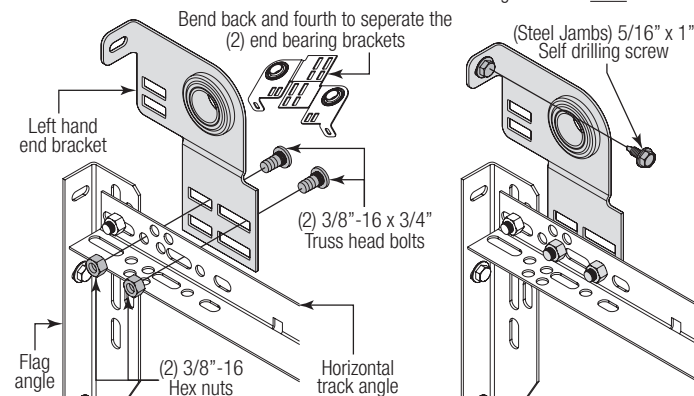

IMPORTANT: THE END BEARING BRACKET'S LOWER SLOTS ARE USED ON DOORS WITH 12" RADIUS TRACK; THE UPPER SLOTS ARE USED ON DOORS WITH 15" RADIUS TRACK.

NOTE: This illustration shows 15" radius track with self drilling screws to Steel.

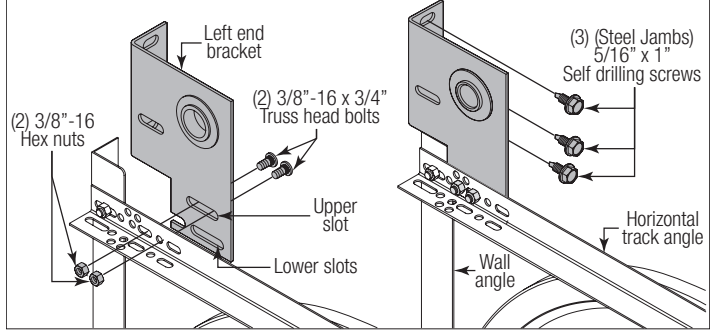

NOTE: This illustration shows 12" or 15" radius track with anchors to Concrete.

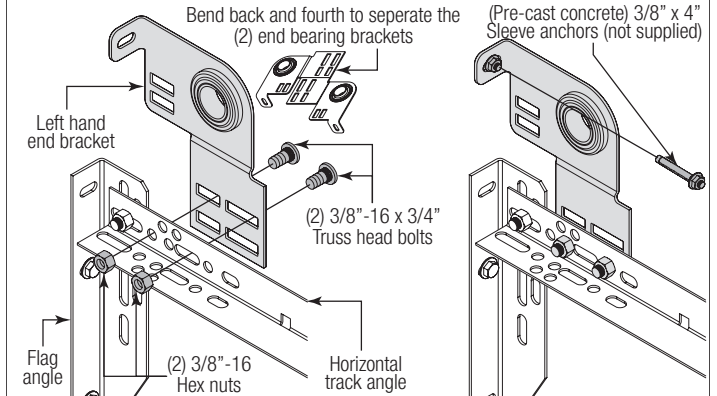

IMPORTANT: THE END BEARING BRACKET'S LOWER SLOTS ARE USED ON DOORS WITH 12" RADIUS TRACK; THE UPPER SLOTS ARE USED ON DOORS WITH 15" RADIUS TRACK.

NOTE: This illustration shows 15" radius track with anchors to Concrete.

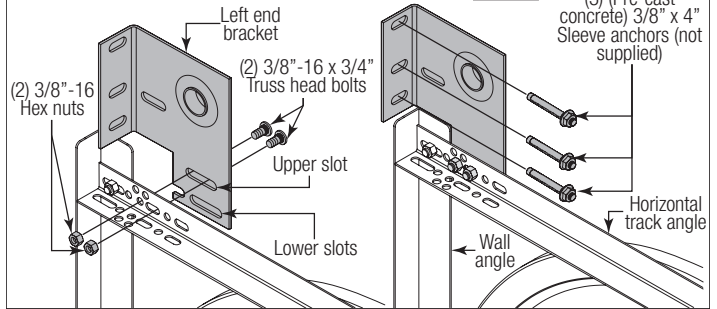

19

Attaching Center Bracket to Wall

NOTE: Refer to Package Contents / Breakdown of Parts, to determine which Center Bracket(s) came with your door.

NOTE: When attaching the center bracket(s) to the spring pads, it has to be at the same elevation as the bearing in the end bearing brackets.

NOTE: Additional center brackets may be required for doors with coupler assembly. Refer to Package Contents / Breakdown of Parts, to determine if you have a coupler assembly.

NOTE: If your door came with (4) or more springs, each of the outer springs mounting surface will need to be a minimum of 3" wide.

NOTE: If needed, measure the diameter of your springs. If you have a one piece shaft with 3-3/4" or larger diameter springs, they do not share center brackets and do not have a coupler assembly.

First, locate the center of the door. Mark a vertical pencil line on the mounting surface above the door, at the center. Measure from the center of the bearing, in one of the end bearing brackets, downwards, to the top of the door. Using that measurement, measure that distance upwards from the top of the door to the mounting surface and mark a horizontal pencil line which intersects the vertical pencil line.

NOTE: On some single spring doors, the spring can be longer than half the opening width. If your spring is longer, then the center bracket must be mounted off center for the spring to fit properly. Measure spring length adding room for spring growth during winding, to determine appropriate center bracket location.

NOTE: Depending on the construction, different fasteners must be used.

FOR WOOD CONSTRUCTION: Align the edge of the center bracket with the vertical pencil line and the center of the center bracket with the horizontal pencil line; this is to ensure the torsion shaft is level between the center and end bearing brackets. Attach the center bracket to the mounting surface, using 5/16" x 1-5/8" lag screws.

NOTE: Drill 3/16" pilot holes into header for the lag screws.

FOR STEEL CONSTRUCTION: Secure each center bracket using (4) 5/16" x 1" self-drilling and tapping screws, as shown.

FOR PRE-CAST CONSTRUCTION: Secure each center bracket using (2) 1/2" x 3" sleeve anchors (by others). This installation will require the 1/2" anchors to be secured to the building and then secure the brackets to the anchors, as shown.

NOTE: Pre-Drill 1/2" pilot holes into the pre-cast for the 1/2" x 3" sleeve anchors.

FOR BLOCK CONSTRUCTION: Attach perforated angle 18" long to center bracket(s) using (2) 3/8" x 1-1/4" bolts and (2) 3/8" nuts. Chamfer angle to clear top section high arc. Secure center bracket(s) and perforated angle to block using (4) 3/8" x 2-1/2" sleeve anchors, as shown.

WARNING

DO NOT USE SLEEVE ANCHORS ON HOLLOW BLOCK.

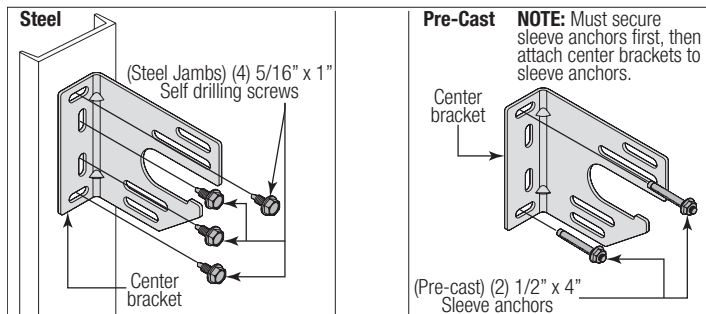
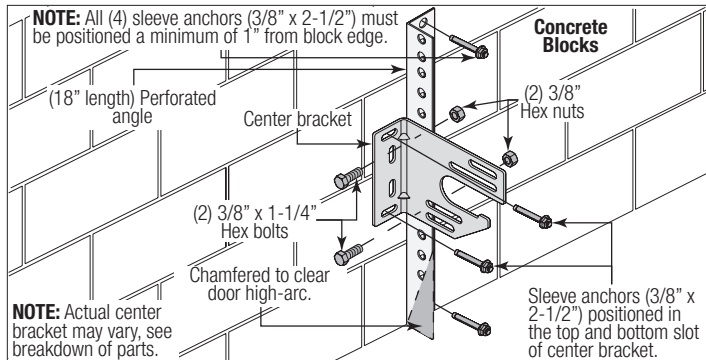
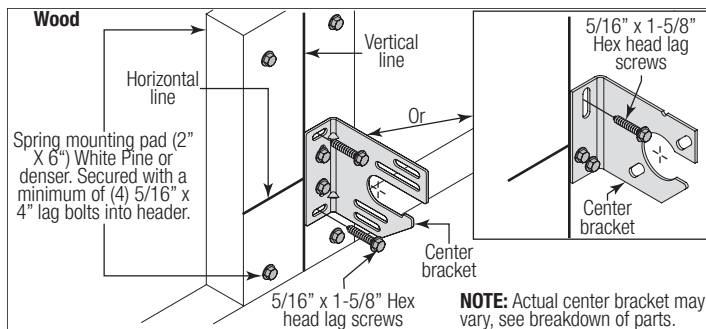

NOTE: Actual center bracket may vary, see breakdown of parts.

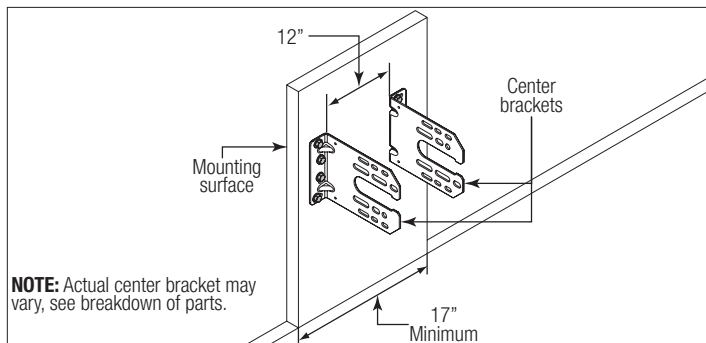

FOR ALTERNATE STEEL SPRING PAD APPLICATIONS:

IMPORTANT: DO NOT BOLT TWO 3-3/4" OR LARGER DIAMETER SPRINGS TO ONE CENTER BRACKET.

WARNING

THESE SPRING MOUNTING TECHNIQUES ARE NOT SUPPORTED FOR 800-32 CABLE DRUMS. THESE INSTRUCTIONS ARE ALSO NOT APPLICABLE FOR 5750-120 CABLE DRUMS WITH 72" OR MORE HIGH-LIFT.

WARNING

MAXIMUM SPACING FOR DIMENSION "Y" IS 84" (7 FT.) THESE INSTRUCTIONS ARE NOT APPLICABLE FOR A SPAN GREATER THAN 84"..

Maximum Door Size 9'0" x 9'0" (Maximum Door Weight 210 lb.)

Cut perforated angle (1-5/8" x 2-3/8" x 11 GA.) to Dim "Y". Thru-bolt top and bottom of angle to each girt using (4) 3/8" x 1-1/4" bolts and (4) 3/8" nuts. Thru-bolt center bracket to perforated angle using (3) 3/8" x 1-1/4" bolts and (3) 3/8" nuts, as shown.

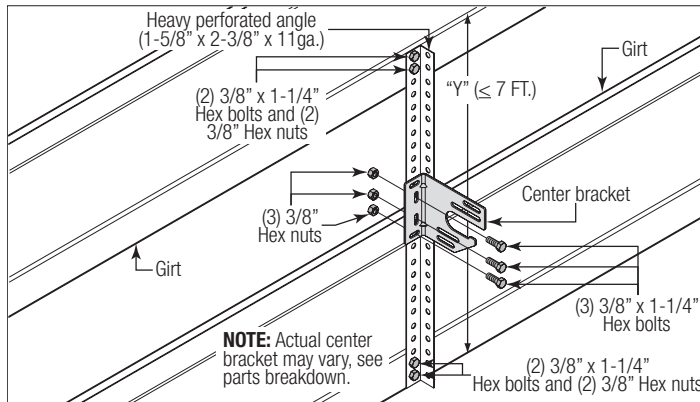

Maximum Door Size 14'0" x 12'0" (Maximum Door Weight 400 lb.)

Cut (2) perforated angle (1-5/8" x 2-3/8" x 11 GA.) to Dim "Y". Thru-bolt top and bottom of each angle to each girt using (4) 3/8" x 1-1/4" bolts and (4) 3/8" nuts. Thru-bolt each center bracket to perforated angle using (3) 3/8" x 1-1/4" bolts and (3) 3/8" nuts, as shown.

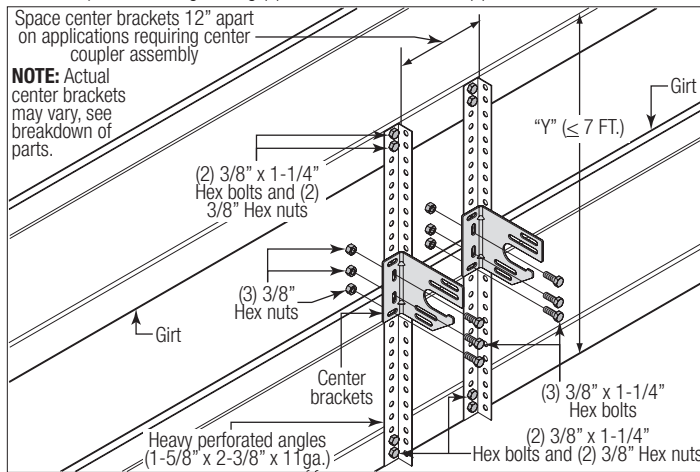

Maximum Door Size 14'-2" x 12'-1" (Maximum Door Weight 800 lb.)

Cut (2) pieces of perforated angle (1-5/8" x 2-3/8" x 11 GA.) to Dim "Y" and (2) more pieces at Dim "Y" minus 3". Bolt the angles together into a "Z" shape using (4) 3/8" x 1-1/4" bolts and (4) 3/8" nuts. Thru-bolt top and bottom of each "Z" shaped angle to each girt using (4) 3/8" x 1-1/4" bolts and (4) 3/8" nuts. Thru-bolt each center bracket to perforated angle assembly using (3) 3/8" x 1-1/4" bolts and (3) 3/8" nuts, as shown.

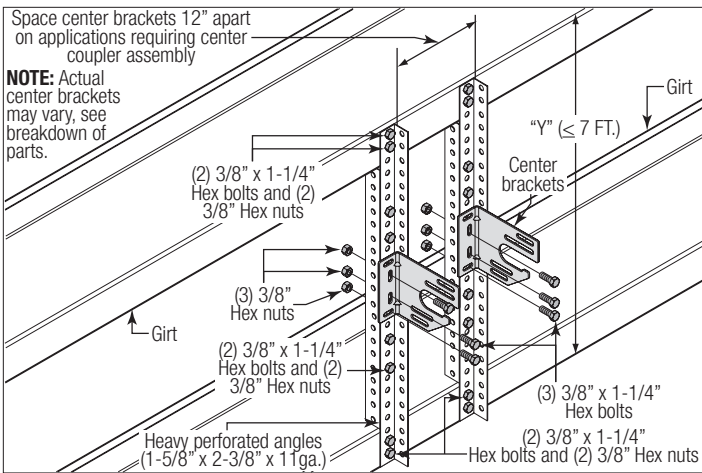

20 Torsion Spring Assembly

IMPORTANT: RIGHT AND LEFT HAND IS ALWAYS DETERMINED FROM INSIDE THE BUILDING LOOKING OUT.

NOTE: Torsion spring assemblies can be of several configurations depending on your door size and door weight.

IMPORTANT: ON SINGLE SPRING APPLICATIONS, ONLY A LEFT HAND WOUND (BLACK WINDING CONE), WHICH GOES ON THE RIGHT HAND SIDE IS REQUIRED.

NOTE: Identify the torsion springs provided as either right hand wound (red winding cone), which goes on the LEFT HAND SIDE or left hand wound (black winding cone), which goes on the RIGHT HAND SIDE.

Facing the inside of the door and referencing the illustrations shown, lay the torsion shaft / torsion keyed shaft(s) on the floor.

NOTE: If your door came with (2) torsion keyed shafts, one torsion keyed shaft should be on the left hand side of the floor and the other torsion keyed shaft should be on the right hand side of the floor.

Lay the torsion spring(s) with the black winding cone and the black cable drum at the right end of the torsion shaft / torsion keyed shaft(s). Lay the torsion spring(s) with the red winding cone and the red cable drum at the left end of the torsion shaft / torsion keyed shaft(s).

NOTE: The set screws used on all torsion winding cones and cable drums are colored red. DO NOT identify right and left hand by the set screw color.

IF YOUR DOOR CAME WITH A COUPLER ASSEMBLY: Disassemble the coupler assembly by removing the (3) 3/8" - 16 x 1-3/4" hex head screws and the (3) 3/8" - 16 nylon hex lock nuts from the coupler halves. Loosen the set screws. Slide the flat edge of the coupler half flush with the side edge of the torsion keyed shaft. Insert (1) key into the slot of both the coupler halves and the slot in the torsion keyed shaft. Tighten the (2) set screws and the locking nut to secure the coupler half to the torsion keyed shaft, as shown.

NOTE: Tighten the set screws to 14-15 ft-lbs (Once set screws contact the shaft, tighten screws an additional 1/2 turn).

Repeat the same processes for the other coupler half.

IMPORTANT: THE COUPLER HALVES, CENTER BEARING(S), TORSION SPRINGS, AND CABLE DRUMS MUST BE POSITIONED, AS SHOWN IN THE ILLUSTRATIONS.

Single Spring Or Double Springs Applications, 1 Piece Shaft, Up To 2-5/8" Springs

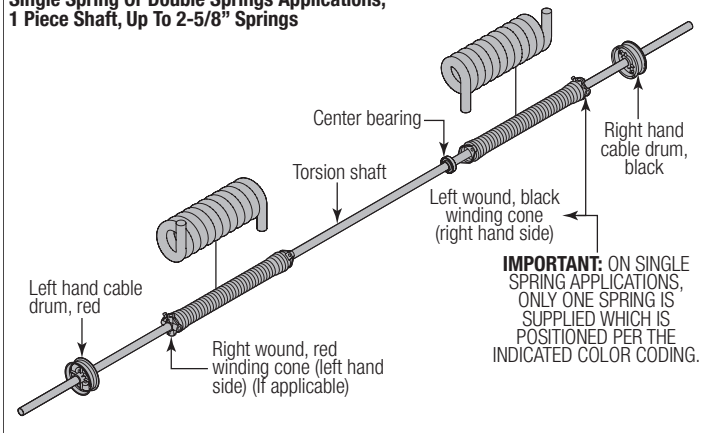

Double Springs Applications, Two Or Four Springs, 1 Piece Shaft, Up To 2-5/8" Springs

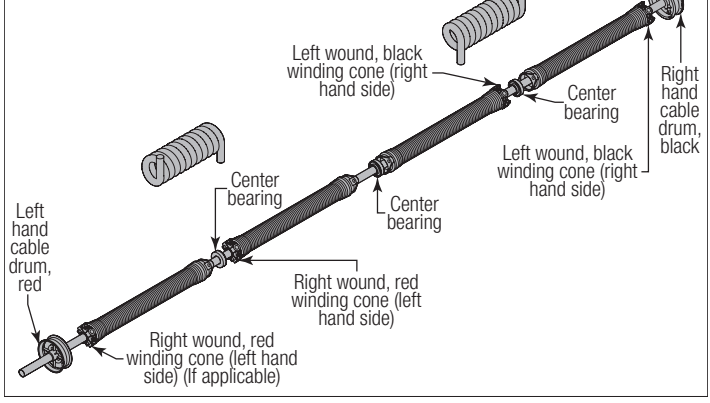

Single Spring Or Double Springs Applications, 1 Piece Shaft, 3-3/4" and 6" Springs

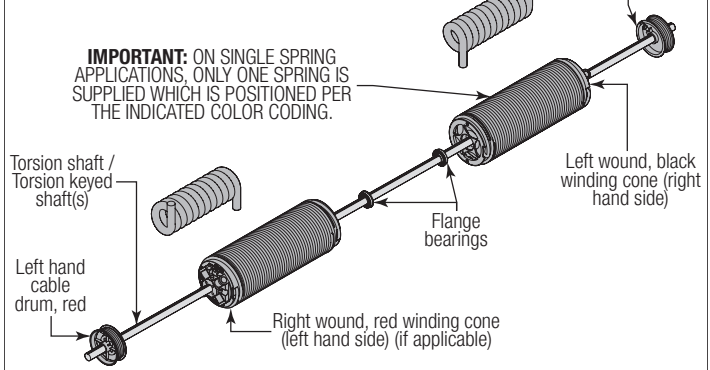

Double Springs Applications, 2 Piece Shafts, Two or 4 springs, up to 6" Springs.

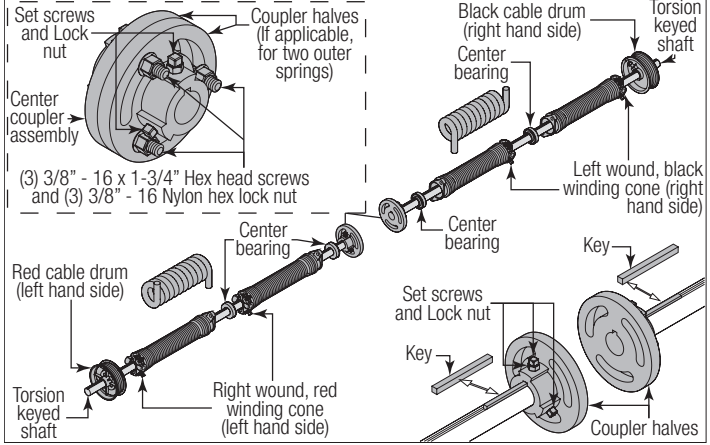

IF YOUR DOOR DOESN'T HAVE A COUPLER ASSEMBLY: With assistance, pick up the torsion spring assembly and slide one end of the torsion shaft / torsion keyed shaft through one end bearing bracket. Lay the middle of the torsion shaft / torsion keyed shaft into the center bearing. Slide the other end of the torsion shaft / torsion keyed shaft into the other end bearing bracket. Position the torsion shaft / torsion keyed shaft so that equal amounts of the shaft extend from each of the end bearing brackets.

NOTE: Position the torsion shaft so that equal amounts of the shaft extend from each end bearing bracket.

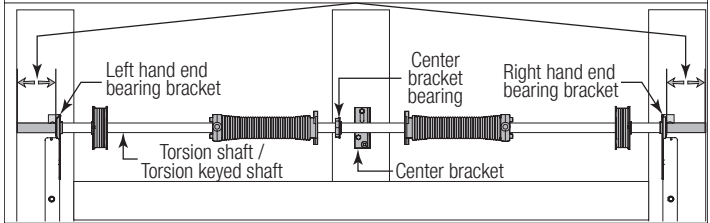

IF YOUR DOOR HAS A COUPLER ASSEMBLY: With assistance and starting on the left hand side of door, pick up the left hand torsion spring assembly and slide one end of the torsion keyed shaft through the end bearing bracket. Lay the other side of the torsion keyed shaft into the center bracket. Repeat the same process for the right hand torsion spring assembly. Position both torsion keyed shafts so that equal amounts of the shafts extend from each of the end bearing brackets.

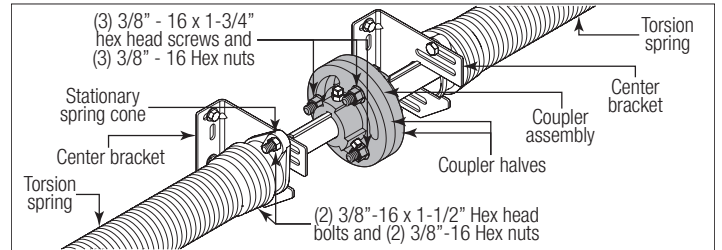
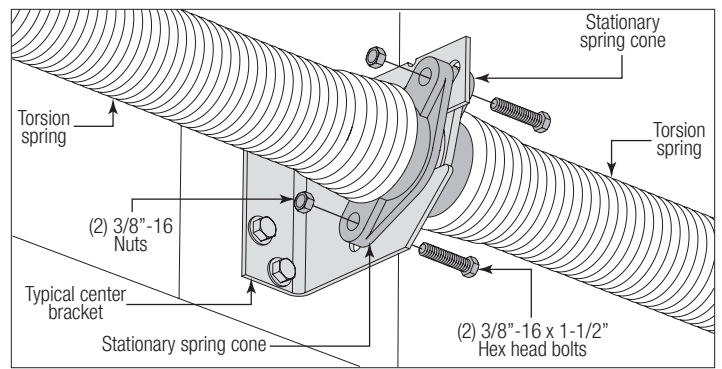
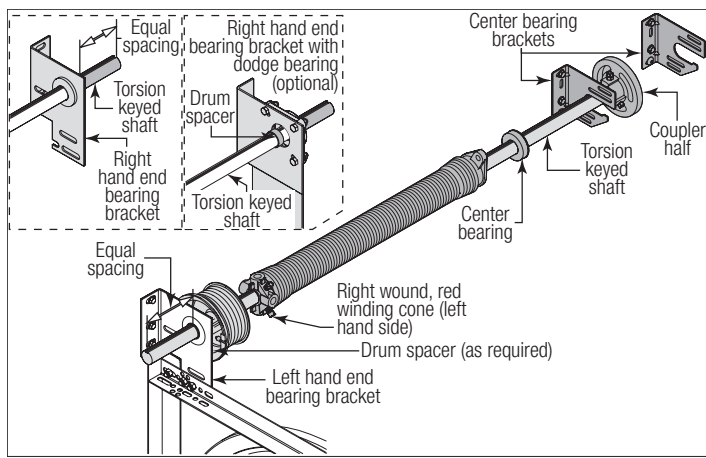

21 Attaching Springs to Center Bracket

NOTE: Refer to Package Contents / Breakdown of Parts, to determine which Center Bracket(s) came with your door.

NOTE: Refer to Package Contents / Breakdown of Parts, to determine if your door came with a coupler assembly.

IMPORTANT: THE SPRING WARNING TAG(S) SUPPLIED MUST BE SECURELY ATTACHED TO THE STATIONARY SPRING CONE(S) IN PLAIN VIEW. SHOULD A REPLACEMENT SPRING WARNING TAG BE REQUIRED, CONTACT WAYNE DALTON FOR FREE REPLACEMENTS.

NOTE: Measure the diameter of your springs. If your spring diameter is 3-3/4", the springs do not share center brackets. If your spring diameter is either 2" or 2-5/8", then two springs will share the same center bracket, unless a coupler assembly is provided.

IF YOU DON'T HAVE A COUPLER ASSEMBLY: Slide center bracket bearing into the spring. Align the stationary spring cone(s) with the holes in the center bracket. Secure the torsion spring(s) to the center bracket with (2) 3/8" - 16 x 1-1/2" hex head bolts and (2) 3/8" - 16 nuts.

IMPORTANT: NEVER USE MORE THAN ONE BEARING WHEN ATTACHING TWO SPRINGS TO ONE CENTER BRACKET.

IF YOU HAVE A COUPLER ASSEMBLY: Slide center bracket bearing into the spring. Align the stationary spring cone with the holes in the center bracket. Secure the torsion spring to the center bracket with (2) 3/8" - 16 x 1-1/2" hex head bolts and (2) 3/8" - 16 nuts. Repeat the same process for the other center bearing bracket.

At the middle of the two center bearing brackets, re-assemble the coupler assembly by loosely fastening the coupler halves together using the (3) 3/8" - 16 x 1-3/4" hex head screws, (6) 3/8" washers, (3) 3/8" lock washers and the (3) 3/8" - 16 hex nuts, previously removed.

NOTE: Ensure both torsion keyed shafts have equal amounts of the shafts extending from each end bearing bracket.

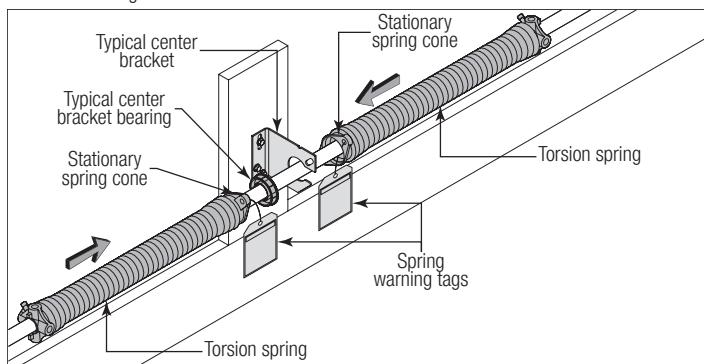

NOTE: Refer to Package Contents / Breakdown of Parts, to determine which Center Bracket(s) came with your door.

NOTE: Refer to Package Contents / Breakdown of Parts, to determine if your door came with a coupler assembly.

IMPORTANT: THE SPRING WARNING TAG(S) SUPPLIED MUST BE SECURELY ATTACHED TO THE STATIONARY SPRING CONE(S) IN PLAIN VIEW. SHOULD A REPLACEMENT SPRING WARNING TAG BE REQUIRED, CONTACT WAYNE DALTON FOR FREE REPLACEMENTS.

FOR SPRINGS UP TO 3-3/4" ID AND IF YOU DON'T HAVE A COUPLER ASSEMBLY: Slide center bearing into the spring (if applicable). Align the stationary spring cone(s) with the holes in the center bracket assembly. Secure the torsion spring(s) to the center bracket assembly with (2) 3/8" - 16 x 1-1/2" hex head bolts and (2) 3/8" - 16 nuts.

IF YOU HAVE A COUPLER ASSEMBLY: Slide the center bearing into the spring. Align the stationary spring cone with the holes in the center bearing bracket.

NOTE: Prior to attaching the torsion spring(s) to the center bracket(s), the torsion shaft / torsion keyed shafts have to be at the same elevation as the bearing in the end bearing brackets. Slide the torsion shaft / torsion keyed shafts out to the correct shaft centerline from the jamba before tightening the spring assembly fasteners.

FOR SPRINGS UP TO 3-3/4" ID: Secure the torsion spring to the center bracket with (2) 3/8" - 16 x 1-1/2" hex head bolts and (2) 3/8" - 16 nuts. Repeat the same process for the other center bearing bracket.

FOR 6" AND DUPLEX SPRINGS: Secure the torsion spring and the flange bearing to the center bracket using (2) 3/8" - 16 x 1" Hex head bolts, as shown.

! WARNING

FOR DUPLEX SPRINGS, YOU MUST ENSURE THE ASSEMBLY BOLTS GO THROUGH THE CENTER BRACKET AND INNER SPRING CONE AND THREAD INTO THE OUTER SPRING CONE AS SHOWN. FAILURE TO ENSURE THE BOLTS ARE SECURING BOTH THE INNER AND OUTER SPRING CONES TO THE CENTER BRACKET CAN RESULT IN SUDDEN SPRING TENSION RELEASE, CAUSING SEVERE OR FATAL INJURY.

At the middle of the two center bearing brackets, loosely re-assemble the coupler assembly by fastening the coupler halves together using the (3) 3/8" - 16 x 1-3/4" hex head screws and the (3) 3/8" - 16 nylon hex lock nuts, as shown.

NOTE: Ensure both torsion keyed shafts have equal amounts of the shafts extending from each end bearing brackets.

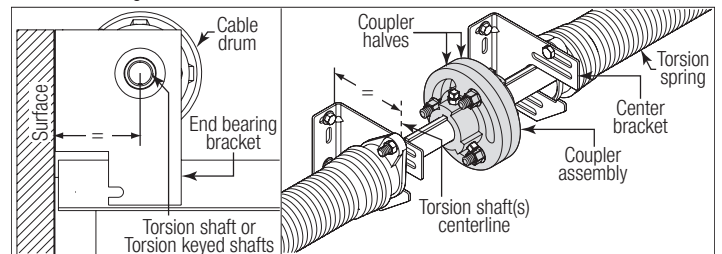

Up To 3-3/4" Springs Applications

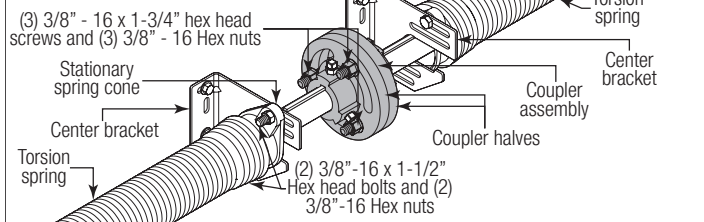

6" Springs Applications

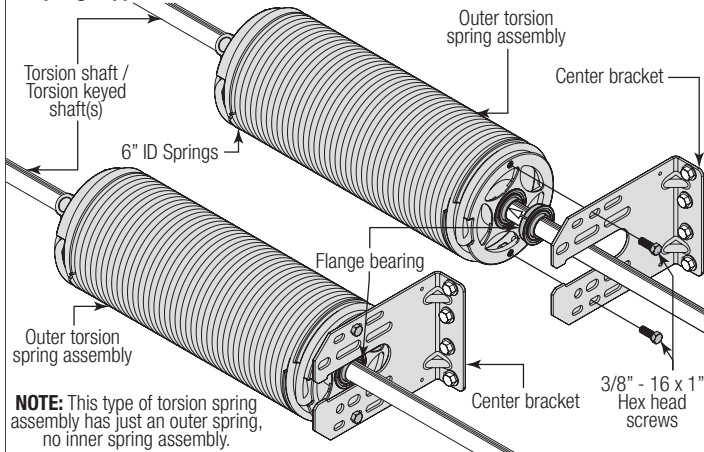

6" Duplex Springs Applications

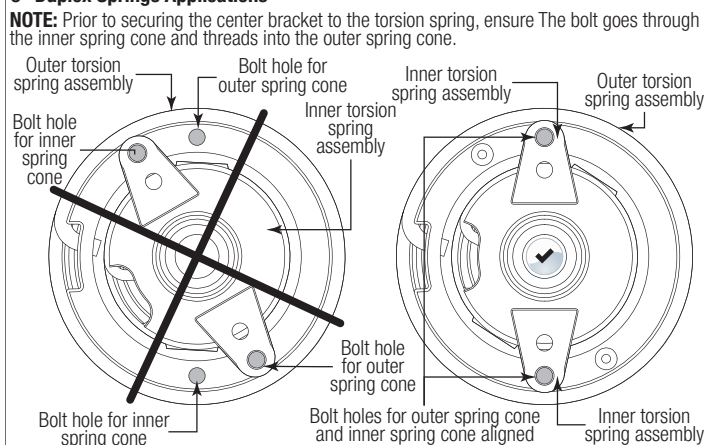

6" Duplex Springs Applications

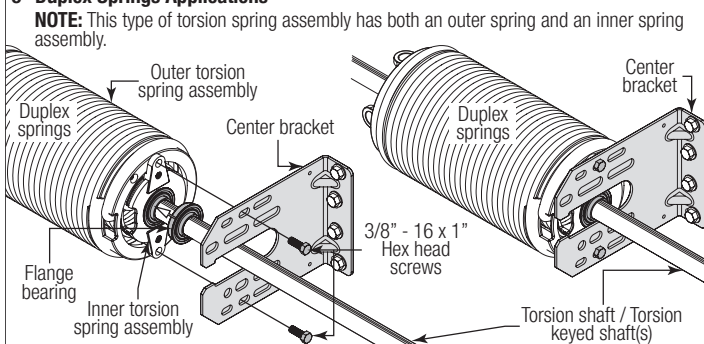

terminate at the 3 o'clock position.

NOTE: If you have torsion keyed shaft(s), insert (1) key into the slot of both the cable drum and the slot in the torsion keyed shaft, as shown.

At the middle of the two center bearing brackets, loosen the (3) 3/8" - 16 x 1-3/4" hex head screws and the (3) 3/8" - 16 nylon hex lock nuts from the coupler assembly (if applicable).

Rotate the left hand drum and torsion shaft until counterbalance lift cable is taut. Now attach locking pliers to the torsion shaft and brace locking pliers up against jamb to keep counterbalance lift cable taut. Tighten the set screws in the drum to 14-15 ft-lbs (Once set screws contact the shaft, tighten screws an additional 1/2 turn for solid shaft and 1 full turn for tubular shaft). Repeat for right hand side.

At the middle of the two center bearing brackets, tighten the (3) 3/8" - 16 x 1-3/4" hex head screws and the (3) 3/8" - 16 nylon hex lock nuts from the coupler assembly (if applicable).

IMPORTANT: INSPECT EACH COUNTERBALANCE LIFT CABLE MAKING SURE IT IS SEATED PROPERLY ONTO THE CABLE DRUM AND THAT BOTH COUNTERBALANCE LIFT CABLES HAVE EQUAL TENSION.

CHECK COUNTERBALANCE LIFT CABLES FOR EQUAL TENSION:

1. Attach locking pliers to track above top roller.
2. Grasp cable at approximate mid-door height location.
3. Draw cable toward you about 1/2" to 1" and release, noting the response of the cable.
4. Repeat above steps for other cable.
5. Adjust cable tension as needed until right and left cables both respond the same.

Once the counterbalance cables are set and if applicable tighten the coupler assembly together by tightening the (3) 3/8" - 16 nylon hex nuts to secure the coupler halves together.

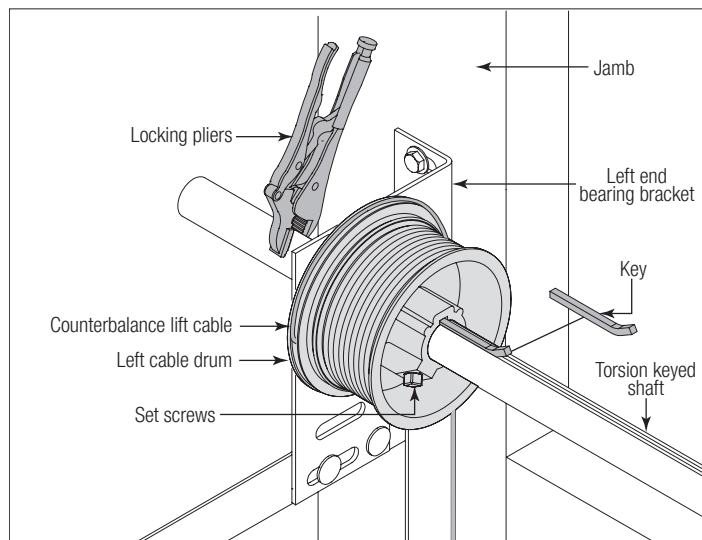
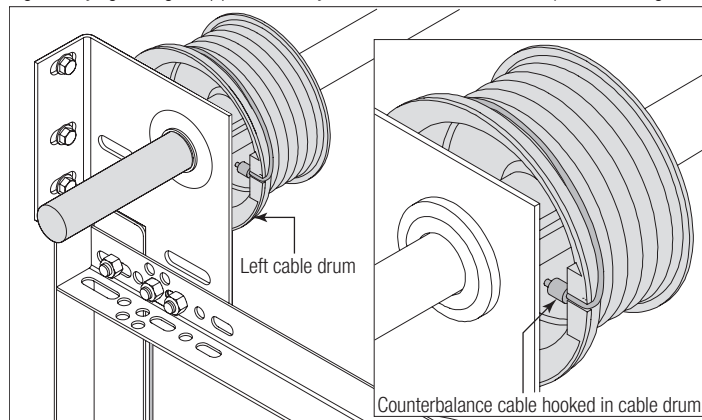

22

Attaching Counterbalance Lift Cables

Starting on the left hand side, thread the counterbalance lift cable up and around the front side of the left hand cable drum.

IMPORTANT: VERIFY THAT THERE ARE NO OBSTRUCTIONS IN THE TRAVEL PATH OF THE DOOR SECTIONS OR COUNTERBALANCE LIFT CABLES.

NOTE: Always assemble the left hand cable and cable drum first to help maintain equal cable tension on both sides of the door.

Hook the counterbalance lift cable into the left hand cable drum. Slide the left hand cable drum up against the left hand end bearing bracket / spacer. Counterbalance lift cable should

NOTE: Prior to securing the cable drum to the torsion shaft / torsion keyed shaft, position the cable drum tight up against the drum spacer.

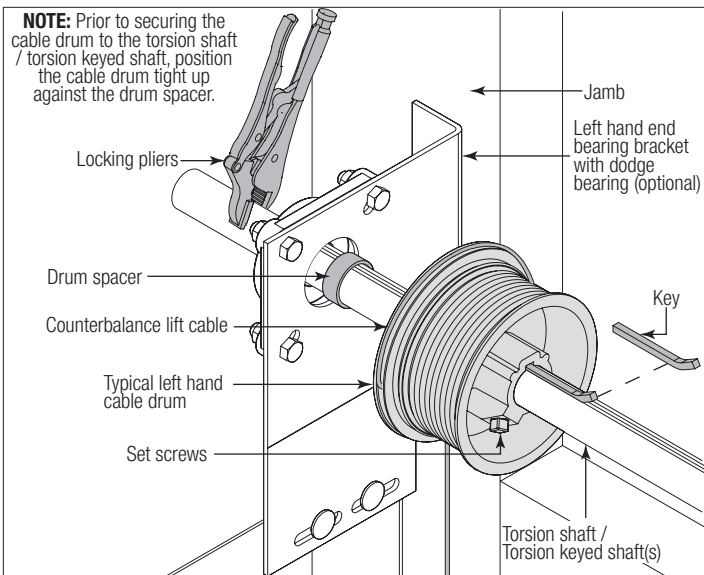

23 Chalking Torsion Spring(s)

NOTE: If your springs have stenciling, then skip this step.

Draw a chalk line horizontally along the center of the torsion spring coil(s). As the torsion spring is wound, the chalk line will create a spiral. This spiral can be used to count and determine the number of turns that are applied on the torsion spring.

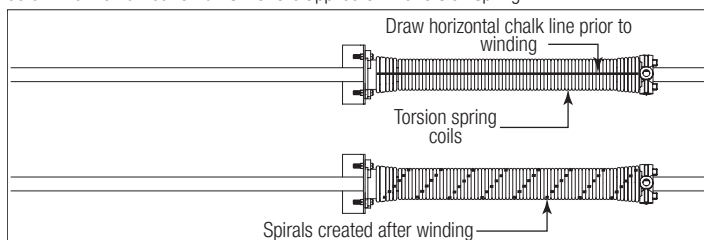

24 Securing Door for Spring Winding

With the door in the fully closed position, place locking pliers onto both vertical tracks just above the third track roller. This is to prevent the garage door from rising while winding springs.

NOTE: Check the following before attempting to wind torsion spring(s):

- Counterbalance lift cables are secured at bottom corner brackets.
- Counterbalance lift cables are routed unobstructed to cable drums.
- Counterbalance lift cables are correctly installed and wound onto cable lift drums.
- Counterbalance lift cables are taut and have equal tension on both sides.
- Cable lift drums are against end bearing brackets and set screws are tight.
- Torsion spring or springs are installed correctly.
- Review the label attached to the spring warning tag, to determine number of spring turns required.

NOTE: Door **MUST** be closed and locked when winding or making any adjustments to the torsion spring(s).

WARNING

FAILURE TO ENSURE DOOR IS IN A CLOSED POSITION AND TO PLACE LOCKING PLIERS ONTO VERTICAL TRACK CAN ALLOW DOOR TO RISE AND CAUSE SEVERE OR FATAL INJURY.

Winding Bars (Steel Rods)	Size Of Winding Bar (Inches)	Spring Inner Diameter Used On
█	1/2" dia. x 18"	2" and 2-5/8"
█	5/8" dia. x 24"	3-3/4"

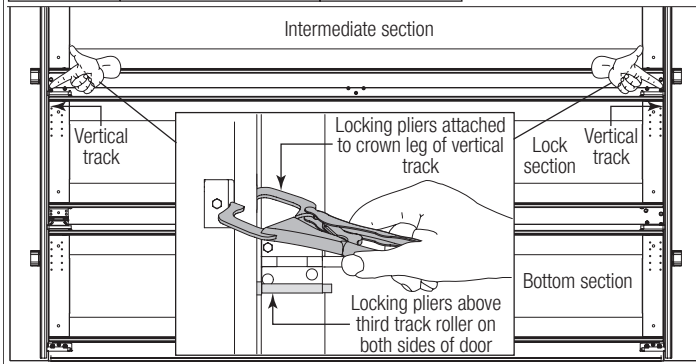

25 Winding Spring(s)

WARNING

WINDING SPRING IS AN EXTREMELY DANGEROUS PROCEDURE AND SHOULD BE PERFORMED ONLY BY A TRAINED DOOR SYSTEM TECHNICIAN USING PROPER TOOLS AND INSTRUCTIONS.

WARNING

USE ONLY SPECIFIED WINDING BARS, AS STATED IN STEP SECURING DOOR FOR SPRING WINDING. DO NOT SUBSTITUTE WITH SCREWDRIVERS, PIPE, ETC. OTHER TOOLS MAY FAIL OR RELEASE FROM THE SPRING CONE AND CAUSE SEVERE OR FATAL INJURY.

WARNING

PRIOR TO WINDING THE SPRING, ENSURE YOU'RE WINDING IN THE PROPER DIRECTION AS SHOWN BELOW. OTHERWISE THE SPRING FITTING MAY RELEASE FROM SPRING AND RESULT IN SEVERE OR FATAL INJURY.

Position a ladder slightly to the side of the spring so that the winding cone is easily accessible, and so your body is not directly in line with the winding bars.

Check the label attached to the spring warning tag for the required number of complete turns to balance your door.

HOW TO WIND TORSION SPRINGS:

- Insert one winding rod snugly into winding cone, to full socket depth
- Maintaining a tight grip on the winding rod rotate it slowly in the proper direction, as shown below.
- If there is any slippage of the winding rod in the winding cone socket, reverse the direction of winding and return the cone to its original position. Remove the winding rod from the winding cone socket. Reseat the winding rod in the socket. Start over at Step #1.
- When the winding rod is vertical above the winding cone, insert another winding rod into one of the other sockets, being careful to seat it snugly and at full socket depth.
- Hold the spring with the second winding bar, and remove the first.
- Repeat Steps #2 through #5 until the complete turns have been applied.

FOR SPRINGS UP TO 3-3/4" ID: Securely hold the winding rod while tightening the 2 set screws in the winding cone to 14-15 ft-lbs of torque (once set screws contact the torsion shaft, tighten screws an additional 1/2 turn for solid shaft and one full turn for tubular shaft).

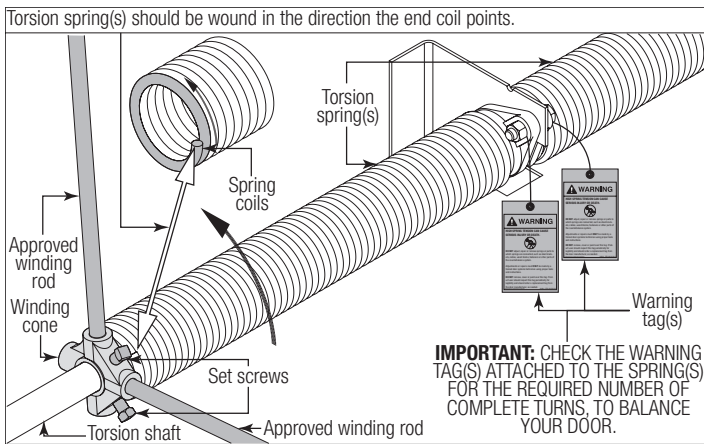

FOR 6" AND DUPLEX SPRINGS: Securely hold the winding rod while tightening the 4 set screws in the winding cone to 25 ft-lbs of torque (once set screws contact the torsion shaft, tighten an additional 1/2 turn).

IMPORTANT: IF YOU HAVE TORSION KEYED SHAFT(S), ONE OF THE SET SCREWS WILL NEED TO BE TIGHTENED INTO THE KEYWAY OF THE TORSION KEYED SHAFT(S).

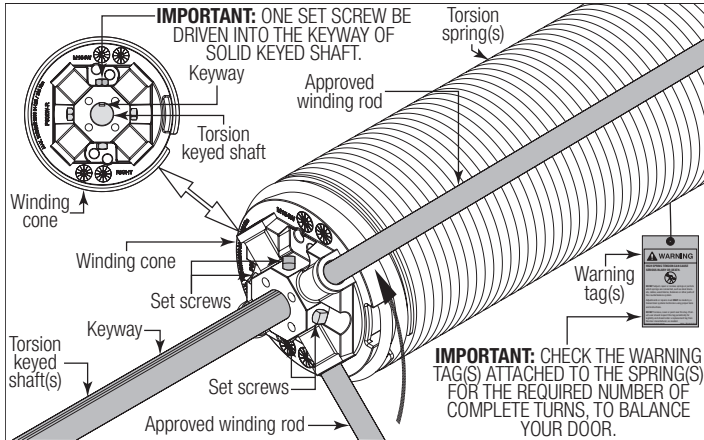

After the torsion spring is secure, use the winding rod to apply pressure in the opposite direction to ensure the set screws are securely fixed to the torsion shaft.

Carefully remove winding rod from winding cone. Repeat for remaining springs, if applicable. While holding the door down to prevent it from raising unexpectedly in the event the spring(s) were over-wound, carefully remove the locking pliers from the torsion shaft and vertical tracks.

NOTE: If you have a coupler assembly, it may be necessary to loosen and retighten the (3) 3/8" - 16 x 1-3/4" hex head screws and the (3) 3/8" - 16 nylon hex lock nuts assembly bolts to equalize the cable tension on both sides of the door.

Adjustments to the number of turns stated may be necessary. If door rises off floor under spring tension alone, reduce spring tension until door rests on the floor. If the door is hard to rise or drifts down on its own, add spring tension.

NOTE: An unbalanced door such as this can cause garage door opener operation problems.

WARNING

DO NOT OPEN DOOR UNTIL STEP REAR BACK HANGS IS COMPLETED.

26

Attaching Rear Back Hangs

IMPORTANT: HOLD THE DOOR DOWN TO PREVENT IT FROM RISING UNEXPECTEDLY IN THE EVENT THE SPRING(S) WERE OVER-WOUND AND CAUTIOUSLY REMOVE LOCKING PLIERS FROM VERTICAL TRACKS.

Raise the door until the top section and half of the next section are in the horizontal track radius. Do not raise door any further since rear of horizontal tracks are not yet supported.

WARNING

RAISING DOOR INTO THE LOOSE HORIZONTAL TRACKS CAN RESULT IN DOOR FALLING AND CAUSE SEVERE OR FATAL INJURY.

Clamp a pair of locking pliers onto the vertical tracks just above the second track roller on one side, and just below the second track roller on the other side. This will prevent the door from raising or lowering while installing the rear back hangs.

Using the chart below, select the appropriate perforated angle (may not be supplied). Fabri-

cate and install rear back hangs, as shown.

Perforated Angle Gauge Weight Limitations:	
Perforated Angle Gauge	Door Balance Weight
2" x 2" x 12 Gauge	800 lbs. to 1600 lbs.
1-1/4" x 1-1/4" x 13 Gauge	305 lbs. to 610 lbs.
1-1/4" x 1-1/4" x 15 Gauge	220 lbs. to 440 lbs.
1-1/4" x 1-1/4" x 16 Gauge	175 lbs. to 350 lbs.

NOTE: If an opener is installed, position horizontal tracks one hole above level when securing it to the rear back hangs.

WARNING

MAKE SURE BACK HANGS ARE BRACED SUFFICIENTLY TO RESIST ANY MOTION DURING SPRING APPLICATION AND DOOR TRAVEL. IF BACK HANGS PIVOT OR DEFLECT, ADD REINFORCEMENT UNTIL THEY REMAIN FIRM AND STATIONARY. ANY BACK HANG THAT IS BENT MUST BE REPLACED.

WARNING

KEEP HORIZONTAL TRACKS PARALLEL AND WITHIN 3/4" TO 7/8" FROM DOOR EDGE, OTHERWISE DOOR COULD FALL, RESULTING IN SEVERE OR FATAL INJURY.

NOTE: Doors heights over 8'0" or door widths over 11'0", require an additional set of rear center back hangs to be installed and located at the middle of the horizontal tracks, see breakdown of parts.

Based on your door width and door heights and using perforated angle (may not be supplied), (2) 5/16" x 1-5/8" hex head lag screws and (3) 5/16" bolts with nuts (may not be supplied), fabricate rear center back hangs for the horizontal tracks, for the following:

FOR ITEM J2, (SEE BREAKDOWN OF PARTS): The Rear Center Back Hang Assemblies are to be used for all doors over 11'0" door height and over 14'0" door width. One Rear Center Back Hang Assembly, per side.

FOR ITEM J3, (SEE BREAKDOWN OF PARTS): The Rear Center Back Hang Assemblies are to be used for all doors over 16'0" door height. Two Rear Center Back Hang Assemblies, per side.

Measure and drill a 3/8" diameter hole through the center length of the horizontal track, as shown. Attach the rear center back hangs to the horizontal tracks with (1) 3/8" Truss head bolt and (1) 3/8" nut (may not be supplied).

IMPORTANT: DO NOT SUPPORT THE WEIGHT OF THE DOOR ON ANY PART OF THE REAR BACK HANGS THAT CANTILEVERS 4" OR MORE BEYOND A SOUND FRAMING MEMBER.

NOTE: If rear back hangs are to be installed over drywall, use (2) 5/16" x 2" hex head lag screws and make sure lag screws engage into solid structural lumber.

WARNING

FAILURE TO ASSEMBLE AND ATTACH REAR BACK HANGS PROPERLY ACCORDING TO THE ABOVE INSTRUCTIONS MAY RESULT IN DOOR FALLING WHEN RAISED, CAUSING SEVERE OR FATAL INJURY.

NOTE: Perforated angle must be attached to sound framing members and **nails should not be used.**

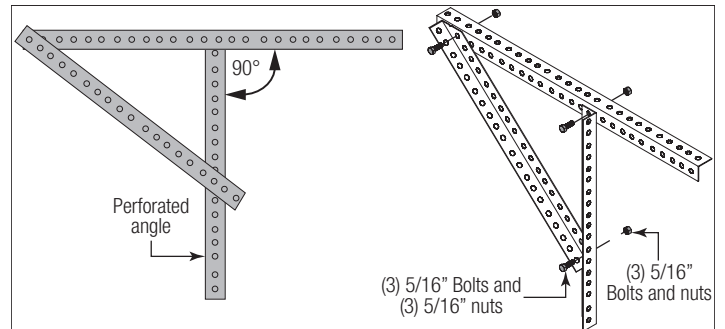

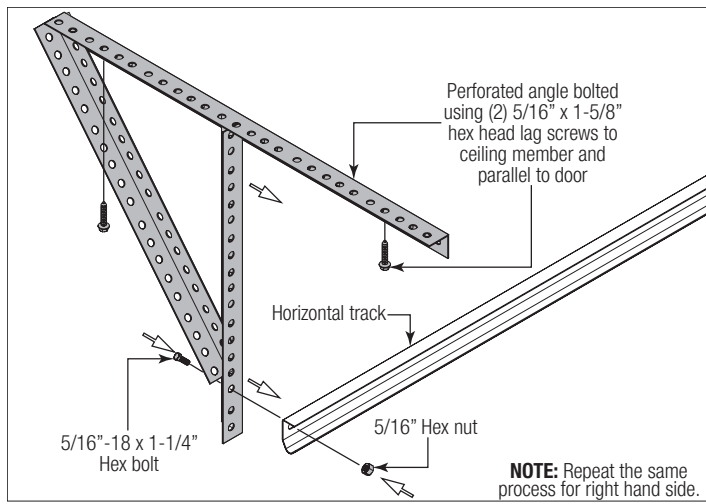

28 Attaching Weather Seal

NOTE: If you don't have weather seals, then skip this step. Refer to Package Contents / Breakdown of Parts, to determine if you have weather seals.

Permanently attach the weatherstrips on both door jambs and header. The weatherstrips were temporarily attached in Preparing the Opening, in the pre-installation section of this manual.

NOTE: When permanently attaching the weatherstrips to the jambs, avoid pushing the weatherstrips too tightly against the face of door.

29 Balancing Door

Remove locking pliers. Lift door and check its balance. Adjustments to the required number of spring turns stated may be necessary. If door rises off floor more than 2 ft. under spring tension alone, reduce spring tension. If the door is hard to rise or drifts down on its own, add spring tension. A poorly balanced door can cause garage door operator problems.

To adjust spring tension, fully close door. Apply locking pliers to track above third track roller. Place locking pliers on torsion shaft, as shown in Step Attaching Counterbalance Lift Cables. Insert a winding rod into the winding cone. Push upward on the winding rod slightly while carefully loosening the set screws in the winding cone.

IMPORTANT: BE PREPARED TO SUPPORT THE FULL FORCE OF THE TORSION SPRING ONCE THE SET SCREWS ARE LOOSE.

Carefully adjust spring tension 1/4 turn. Retighten both set screws to 14-15 ft. lbs. of torque in the winding cone and repeat for the other side. Recheck door balance and re-adjust spring tension if needed.

IMPORTANT: DO NOT ADJUST MORE THAN 1 TURN FROM THE RECOMMENDED NUMBER OF TURNS.

If the door still does not operate easily, lower the door into the closed position, unwind spring(s) completely, and recheck the following items:

- 1.) Is the door level?
- 2.) Are the torsion shaft and flag angles / angle mount level and plumb?
- 3.) Does the distance between the flag angles / angle mount equal door width plus 3-3/8" to 3-1/2"?
- 4.) Do the counterbalance lift cables have equal tension? Adjust if necessary.
- 5.) Rewind the spring(s).
- 6.) Make sure door is not rubbing on jambs.

IMPORTANT: IF DOOR STILL DOES NOT BALANCE PROPERLY, THEN CONTACT A TRAINED DOOR SYSTEM TECHNICIAN.

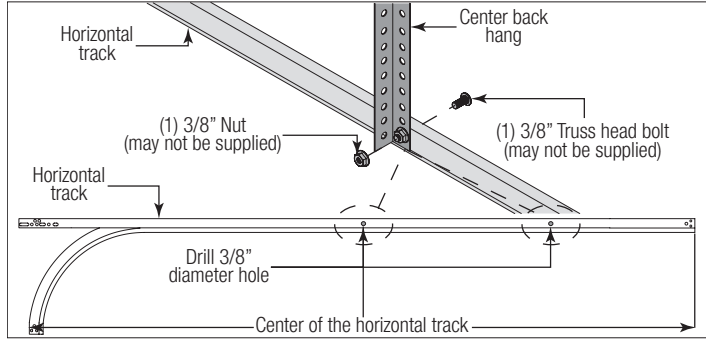
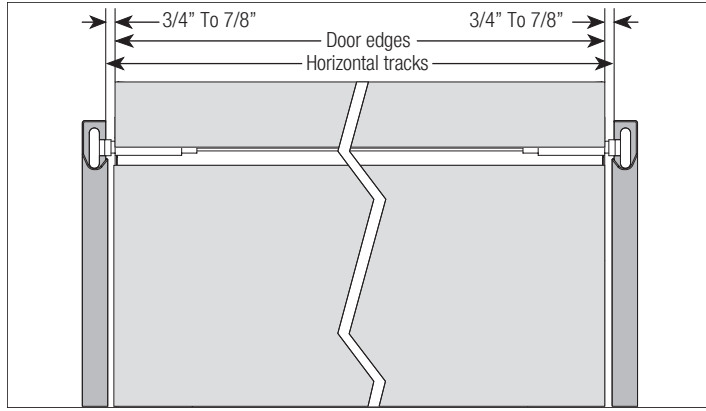

MAINTENANCE

Cleaning Your Garage Door

IMPORTANT: DO NOT USE A PRESSURE WASHER ON YOUR GARAGE DOOR!

While factory-applied finishes on garage doors are durable, it is desirable to clean them on a routine basis. Some discoloration of the finish may occur when a door has been exposed to dirt-laden atmosphere for a period of time. Slight chalking may also occur as a result of direct exposure to sunlight.

Cleaning the door will generally restore the appearance of the finish. To maintain an aesthetically pleasing finish of the garage door, a periodic washing of the garage door is recommended.

THE FOLLOWING CLEANING SOLUTION IS RECOMMENDED:

A mild detergent solution consisting of one cup detergent (with less than 0.5% phosphate) dissolved into five gallons of warm water will aid in the removal of most dirt.

NOTE: The use of detergents containing greater than 0.5% phosphate is not recommended for use in general cleaning of garage doors.

NOTE: Be sure to clean behind weatherstrips on both sides and top of door.

CAUTION
NEVER MIX CLEANSERS OR DETERGENTS WITH BLEACH.

GLASS CLEANING INSTRUCTIONS

Clean with a mild detergent solution (same as above) and a soft cloth. After cleaning, rinse thoroughly.

ACRYLIC CLEANING INSTRUCTIONS

Clean acrylic glazing with nonabrasive soap or detergent and plenty of water. Use your bare hands to feel and dislodge any caked on particles. A soft, grit-free cloth, sponge or chamois

27 Cable Keepers

NOTE: If you don't have cable keepers, then skip this step. Refer to Step 4 Attaching Cable Keepers, to determine if you have cable keepers installed.

IMPORTANT: CABLE KEEPERS ARE INTENDED TO HELP PREVENT COUNTERBALANCE LIFT CABLES FROM COMING OFF CABLE DRUMS ON MANUALLY OPERATED DOORS. ADDITIONAL CABLE TENSIONING PROVISIONS MAY BE REQUIRED FOR MOTOR OPERATED DOORS.

Rotate arm up and hook around counterbalance lift cable, letting the cable keeper arm pull against the counterbalance lift cable, keeping it taut, as shown. Next, close the hook to prevent the counterbalance lift cables from coming out.

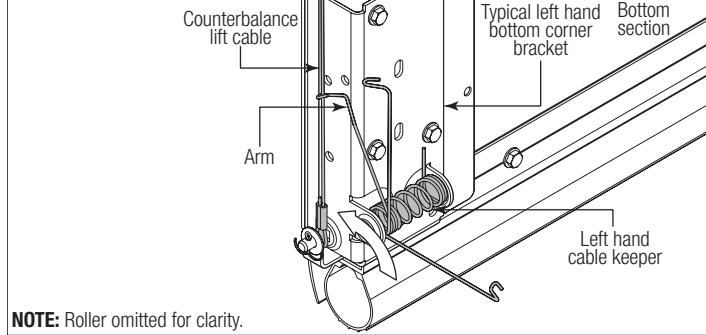

may be used to wipe the surface. Do not use hard or rough cloths that will scratch the acrylic glazing. Dry glazing with a clean damp chamois.

NOTE: Do not use any window cleaning fluids, scouring compounds, gritty cloths or solvent-based cleaners of any kind.

Painting Your Garage Door

SURFACE PREPARATION FOR PAINTING

Wax on the surface must be removed or paint peeling/ flaking will result. To remove this wax, it will be necessary to lightly scuff the surface with a fine steel wool pad saturated with soapy water. A final wipe and rinse should be done with clean water only to remove any loose particles and any soapy film residue.

Surface scratches, which have not exposed the metal substrate, can be lightly buffed or sanded with 0000 steel wool or no. 400 sand paper to create a smoother surface. Care must be taken to not expose the substrate under the paint. Once the substrate is exposed, the likelihood for rusting is greatly increased.

If substrate is exposed, it must be treated to prevent rust from forming. Sand the exposed area lightly and paint with a high quality metal primer specifically intended for galvanized surfaces to protect the area from corrosion. Allow for drying time on primer can label before applying topcoat.

The surface of the factory-applied finish, that is being painted, must not be too smooth, or the paint will not adhere to it. It is advisable to test in an inconspicuous area, to evaluate adhesion. If poor adhesion is observed, surface preparation for painting the factory-applied finish must be repeated until desired results are achieved. Again, care must be taken to not expose the substrate under the paint.

PAINTING:

After surface has been properly prepared, it must be allowed to dry thoroughly, and then coated immediately with premium quality latex house paint. Follow paint label directions explicitly. Oil base or solvent base paints are not recommended. Please note that if substrate is exposed and not properly primed, painting with latex paint may cause accelerated rusting of the steel in the exposed area.

NOTES:

1. Re-painting of finish painted steel doors cannot be warranted, as this condition is totally beyond the door manufacturer's control.
2. Consult a professional coatings contractor if in doubt about any of the above directions.
3. Follow directions explicitly on the paint container labels for proper applications of coatings and disposal of containers. Pay particular attention to acceptable weather and temperature conditions in which to paint.

Operation And Maintenance

OPERATING YOUR GARAGE DOOR:

Before you begin, read all warning labels affixed to the door and the installation instructions and owner's manual. When correctly installed, your Wayne Dalton door will operate smoothly. Always operate your door with controlled movements. Do not slam your door or throw your door into the open position, this may cause damage to the door or its components. If your door has an electric opener, refer to the owner's manual to disconnect the opener before performing manual door operation below.

MANUAL DOOR OPERATION:

For additional information on manual garage door operations go to www.dasma.com and reference TDS 165.

IMPORTANT: DO NOT PLACE FINGERS OR HANDS INTO SECTION JOINTS WHEN OPENING AND/OR CLOSING A DOOR. ALWAYS USE LIFT HANDLES / SUITABLE GRIPPING POINTS WHEN OPERATING THE DOOR MANUALLY.

Opening a Door: Make sure the lock(s) are in the unlocked position. Lift the door by using the lift handles / suitable gripping points only. Door should open with little resistance.

Closing a Door: From inside the garage, pull door downward using lift handles / gripping points only or a high friction area only. If you are unable to reach the lift handles/ suitable gripping points only, use pull down rope affixed to the side of door. Door should close completely with little resistance.

USING AN ELECTRIC OPERATOR:

IMPORTANT: PULL DOWN ROPES MUST BE REMOVED AND LOCKS MUST BE REMOVED OR MADE INOPERATIVE IN THE UNLOCKED POSITION.

When connecting a drawbar (trolley type) garage door operator to this door, a drawbar operator and or drawbar operator bracket must be securely attached to the top section of the door, along with any struts provided with the door. Always use the drawbar operator and or drawbar operator bracket supplied with the door. To avoid possible damage to your door, Wayne Dalton recommends reinforcing the top section with a strut (may or may not be supplied). The installation of the drawbar operator must be according to manufacturer's instructions and force settings must be adjusted properly. Refer to the owner's manual supplied with your drawbar operator for complete details on installation, operation, maintenance and testing of the operator.

MAINTAINING YOUR GARAGE DOOR:

Before you begin, read all warning labels affixed to the door and the installation instructions and owner's manual. Perform routine maintenance steps once a month, and have the

door professionally inspected once a year. Review your Installation Instructions and Owner's Manual for the garage door. These instructions are available at no charge from Wayne Dalton, a division of Overhead Door Corporation, P.O. Box 67, Mt. Hope, OH., 44660, or at www.Wayne-Dalton.com. For additional information on garage door/operator maintenance go to www.dasma.com and reference TDS 151, 167 and 179.

MONTHLY INSPECTIONS:

1. Visual Inspection: Closely inspect jambs, header and mounting surface. Any wood found not to be structurally sound must be replaced. Inspect the springs, counterbalance lift cables, track rollers, pulleys, rear back hangs and other door hardware for signs of worn or broken parts. Tighten any loose screws and/or bolts. Check exterior surface of the door sections for any minor cracks. Verify door has not shifted right or left in the opening. If you suspect problems, have a trained door system technician make the repairs.

WARNING

GARAGE DOOR SPRINGS, COUNTERBALANCE LIFT CABLES, BRACKETS, AND OTHER HARDWARE ATTACHED TO THE SPRINGS ARE UNDER EXTREME TENSION, AND IF HANDLED IMPROPERLY, CAN CAUSE SEVERE OR FATAL INJURY. ONLY A TRAINED DOOR SYSTEMS TECHNICIAN SHOULD ADJUST THEM, BY CAREFULLY FOLLOWING THE MANUFACTURER'S INSTRUCTIONS.

WARNING

NEVER REMOVE, ADJUST, OR LOOSEN THE BOLTS, SCREWS AND/OR LAG SCREWS ON THE COUNTERBALANCE (END OR CENTER BEARING BRACKETS) SYSTEM OR BOTTOM CORNER BRACKETS OF THE DOOR. THESE BRACKETS ARE CONNECTED TO THE SPRING(S) AND ARE UNDER EXTREME TENSION. TO AVOID POSSIBLE SEVERE OR FATAL INJURY, HAVE ANY SUCH WORK PERFORMED BY A TRAINED DOOR SYSTEMS TECHNICIAN USING PROPER TOOLS AND INSTRUCTIONS.

TORSION SPRINGS: The torsion springs (located above the door) should only be adjusted by a trained door systems technician. DO NOT attempt to repair or adjust torsion springs yourself.

EXTENSION SPRINGS: A restraining cable or other device should be installed on the extension spring (located above the horizontal tracks) to help contain the spring if it breaks.

2. Door Balance: Periodically test the balance of your door. If you have a garage door drawbar operator, use the release mechanism so you can operate the door by hand when doing this test. Start with the door in the fully closed position. Lift the door to check its balance. Adjust Extension spring(s), if door lifts by itself (hard to pull down) or if door is difficult to lift (easy to pull down). DO NOT attempt to repair or adjust Torsion Springs yourself. To adjust Extension spring(s), refer to your installation instructions and owner's manual. If in question about any of the procedures, do not perform the work. Instead, have it adjusted by a trained door systems technician.

3. Lubrication: The door should open and close smoothly. Ensure the door track rollers are rotating freely when opening and closing the door. If track rollers do not rotate freely, clean the door tracks, removing dirt and any foreign substances. Clean and lubricate (use a non-silicon based lubricant) graduated end hinges, center hinge(s), steel track rollers, bearings and torsion spring(s) (torsion spring coil surfaces). DO NOT lubricate plastic idler bearings, nylon track rollers, door track. DO NOT oil a cylinder lock, if actuation is difficult use a graphite dust to lubricate.



Commercial Sectional

ThermoMark™ Door and Operator System

Limited Warranty

Wayne Dalton, a division of Overhead Door Corporation ("Seller") warrants to the original purchaser of the ThermoMark™ Models 530, 5150, 5155, 5200, and 5255 ("Door") and Genie GCL-MH, MJ, MT, H, J, T, GH, or GT commercial operator ("Operator") (Door and Operator purchased and installed together collectively referred to as the "System"), subject to all of the terms and conditions hereof, that the System and all components thereof will be free from defects in materials and workmanship for the following period(s) of time, measured from the date of installation:

- **TEN (10) YEARS** against cracking, splitting, rust deterioration and delamination
- **THREE (3) YEARS** against defects in materials and workmanship on all components of the System, excluding the counterbalance spring and finish, or 20,000 cycles¹, whichever occurs first.
- **TWO (2) YEARS** against peeling or color fade of finish on Product sections with Black finish or Walnut, Mission Oak, or Golden Oak wood grain finish which materially alters the color of the Product and cannot be remedied by cleaning with the recommended solution.

Seller's obligation under this warranty is specifically limited to repairing or replacing, at its option, any part which is determined by Seller to be defective during the applicable warranty period. Any labor charges are excluded and will be the responsibility of the purchaser.

This warranty is made to the original purchaser of the System only, and is not transferable or assignable. This Product is intended for commercial and industrial applications only. Use in a non-approved application will void this warranty. This warranty does not apply to any unauthorized alteration or repair of the System, or to any System or component which has been damaged or deteriorated due to misuse, neglect, accident, failure to provide necessary maintenance, normal wear and tear, acts of God, or any other cause beyond the reasonable control of Seller or as a result of having been exposed to toxic or abrasive environments, including humidity, blowing sand, salt water, salt spray and toxic chemicals and fumes. This warranty does not cover replacement batteries and applies only to Systems (a Door and Operator purchased and installed together simultaneously) and not to any Door or Operator purchased independently from the other, regardless of whether subsequently paired together.

THIS WARRANTY IS EXCLUSIVE AND IN LIEU OF ANY OTHER WARRANTIES, EITHER EXPRESS OR IMPLIED, INCLUDING BUT NOT LIMITED TO ANY IMPLIED WARRANTY OF MERCHANTABILITY OR FITNESS FOR A PARTICULAR PURPOSE.

IN NO EVENT SHALL SELLER BE RESPONSIBLE FOR, OR LIABLE TO ANYONE FOR, SPECIAL, INDIRECT, COLLATERAL, PUNITIVE, INCIDENTAL OR CONSEQUENTIAL DAMAGES, even if Seller has been advised of the possibility of such damages. Such excluded damages include, but are not limited to, loss of use, cost of any substitute product, or other similar indirect financial loss.

Claims under this warranty must be made promptly after discovery, within the applicable warranty period, and in writing to the authorized dealer or installer whose name and address appear below. The purchaser must allow Seller a reasonable opportunity to inspect any System claimed to be defective prior to removal or any alteration of its condition. Proof of the purchase and/or installation date, and identification as the original purchaser, may be required.

¹The number of cycles referred to herein shall be measured by an integrated cycle counter contained in or attached to the Operator. If the cycle counter is rendered inoperable, Seller shall use other reasonable means to determine the cycle count.

SELLER: _____

SELLER'S ADDRESS: _____

Thank you for your purchase.

If you need assistance, please call 1-866-569-3799 (press Option 1) and follow the prompts to contact a customer service representative. They will be happy to handle any questions that you may have.

After installation is complete, leave this Installation Instructions And Owner's Manual with the homeowner, or fasten it near garage door for easy reference.