



# “SPECIFIC PRODUCT SHEET”

## 24,20, & 16 GA.

**THIS MUST ACCOMPANY “GENERAL INSTALLATION” BOOKLET. IF IT DOES NOT, CONTACT WAYNE-DALTON BEFORE ATTEMPTING INSTALLATION**

Use this insert in conjunction with the installation manual provided with the door. Follow the corresponding steps in this insert with the steps in the installation manual.

### ► Step 3

Secure cables to the endstile using a cotter pin and washer as detailed. Attach brackets to the section using 1/4-20 X 3/4” Hex Head Bolts in the holes as shown.

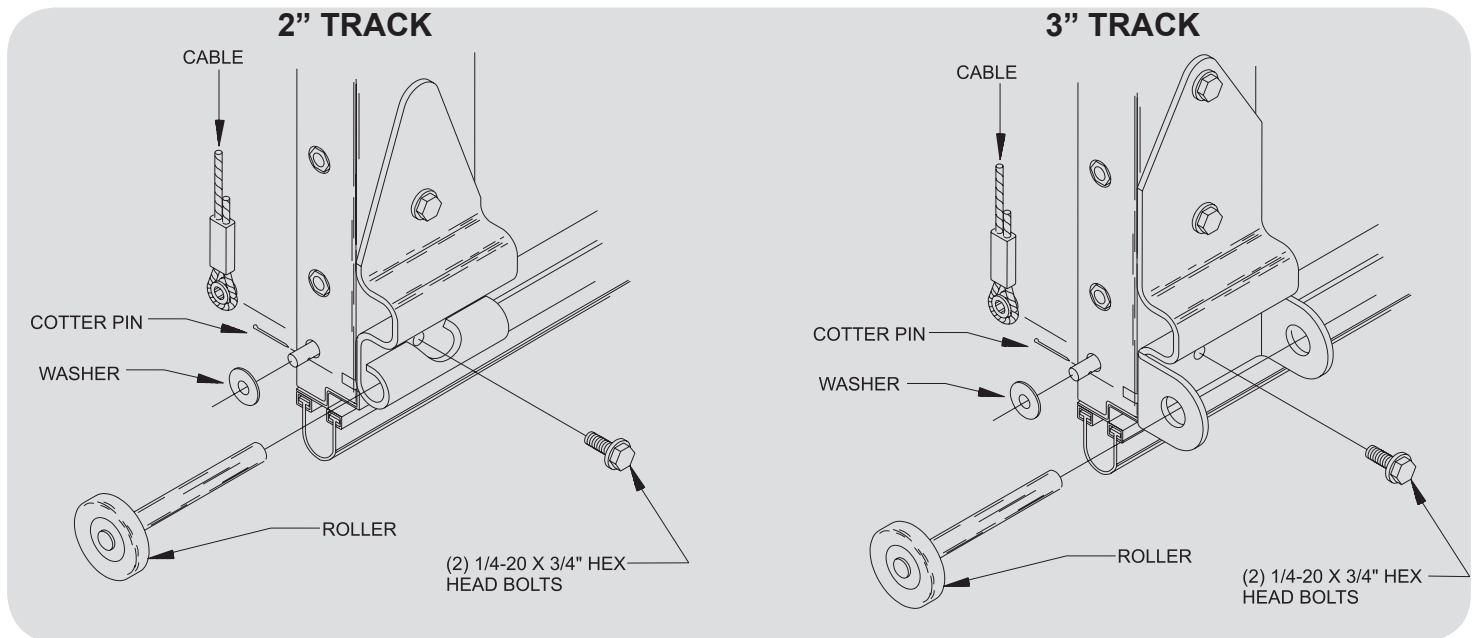

Drill a 1/4” hole from inside out in one of the center muntin legs on the bottom section. Then from the outside using the lift handle bolted up in the drilled hole as a template drill another hole and assemble.

Attach lift handles in desired location on bottom retainer by using handle as a drill template. Drill (2) 1/4” holes thru section then enlarge those holes from the inside out but DON'T go thru outside skin on the door. Then assemble as shown.

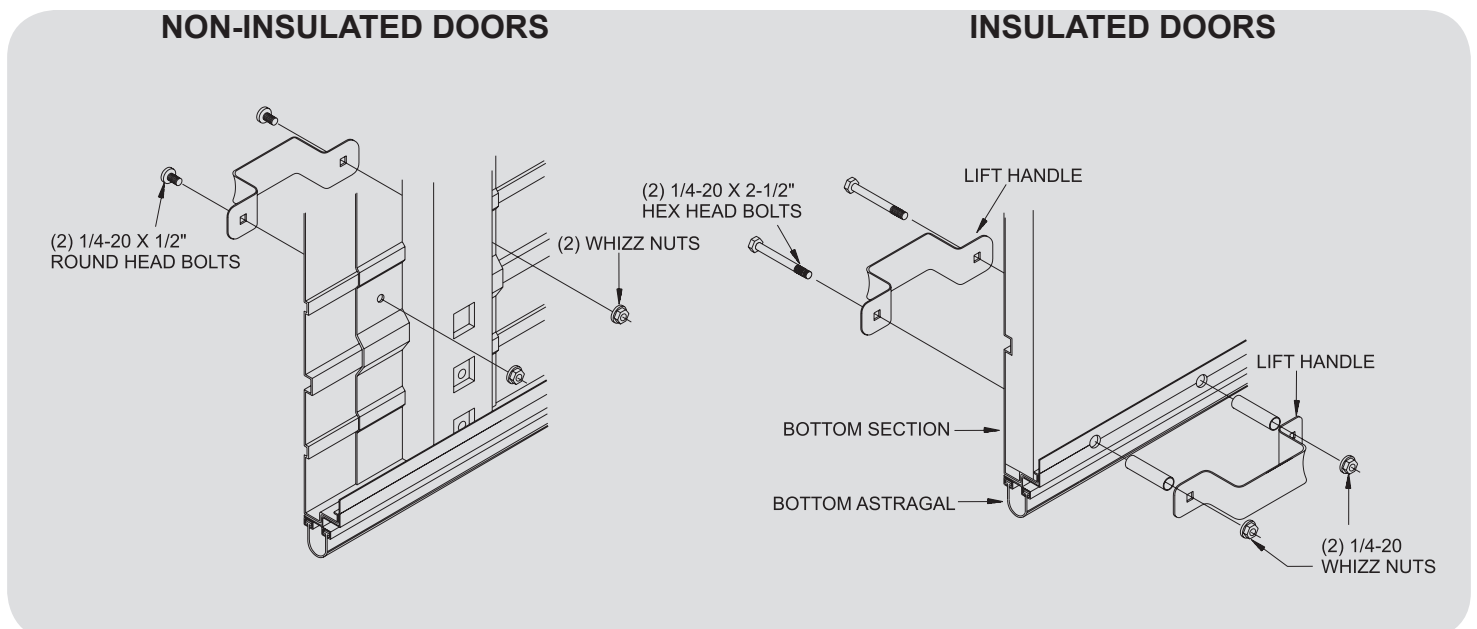

## HINGE INSTALLATION

Attach hinges to the section using 1/4-20 X 3/4" Hex Head Bolts. (Refer to **FIGURE A**)

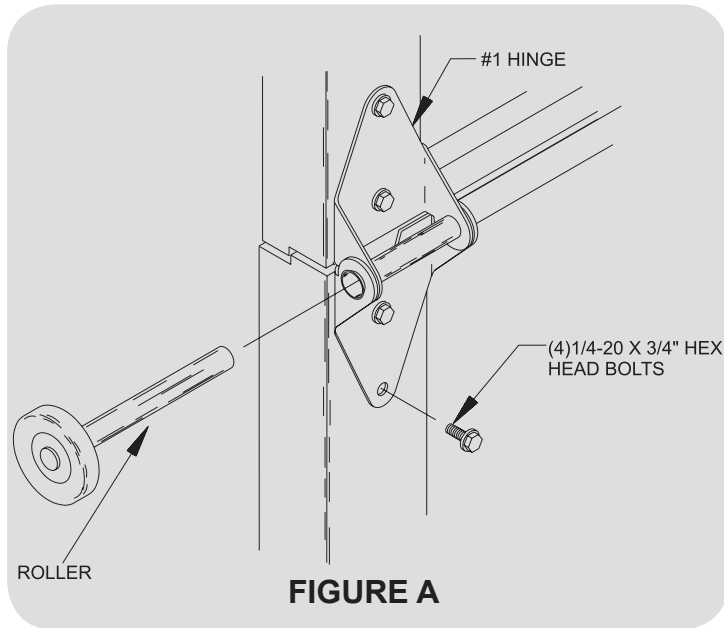

## TOP BRACKET INSTALLATION

### Step 6

Place a roller in the top bracket so holes in bracket line up with holes in muntin and attach using (2) 1/4-20 X 3/4" Hex Head Bolts as detailed in **FIGURE B**.

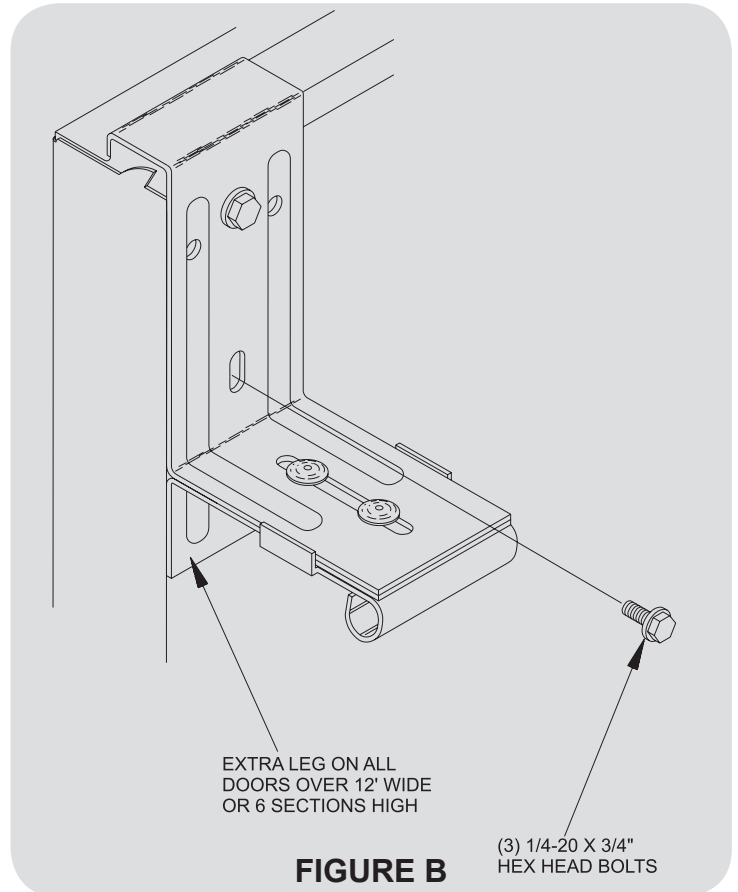

## STANDARD STRUTTING: (15.2 PSF)

### Step 7

Doors requiring struts, attach using 1/4-20 X 7/8" Self Drilling Screws as shown mounting below the end and center hinge leaves. (Refer to **FIGURE C**)

**NOTE:** When installing two struts per section install one strut under the lower hinge leaves and the other above the upper hinge leaves on the section.

#### 16 Ga. Doors

Doors 16'3" wide thru 20'2" wide require a 3" strut every section  
Doors 20'3" wide thru 25'2" wide require a 6" welded truss every section  
Doors 25'3" wide thru 26'2" wide require a 8" welded truss every section

#### 20 Ga. Doors

Doors 14'3" wide thru 16'2" wide require a 2" strut every section  
Doors 16'3" wide thru 20'2" wide require a 3" strut every section  
Doors 20'3" wide thru 24'2" wide require a 6" welded truss every section  
Doors 24'3" wide thru 30'2" wide require a 8" welded truss every section

#### 24 Ga. Doors

Doors 12'3" wide thru 14'2" wide & less than 9 sections high have a 2" strut every other section  
Doors 12'3" wide thru 14'2" wide & more than 8 sections high have a 2" strut every section  
Doors 14'3" wide thru 16'2" wide require a 2" strut every section  
Doors 16'3" wide thru 20'2" wide require a 3" strut every section  
Doors 20'3" wide thru 24'2" wide require a 6" welded truss every section  
Doors 24'3" wide thru 28'2" wide require a 8" welded truss every section

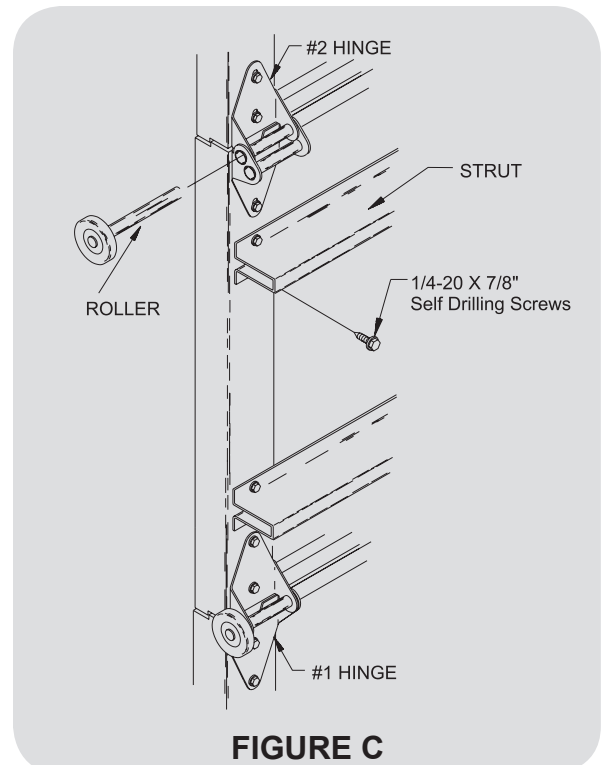

# LOCK INSTALLATION

## ► Step 13

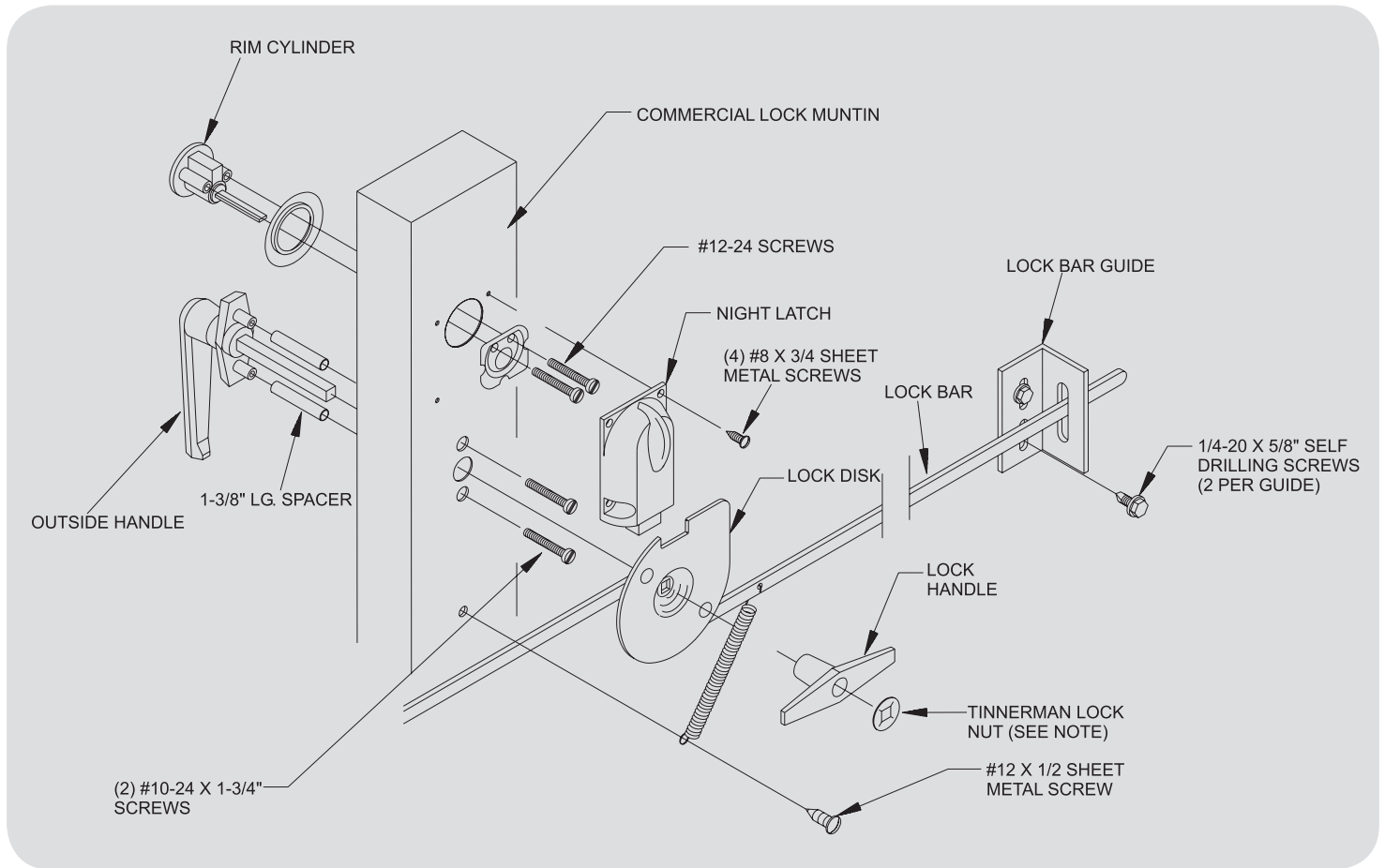

### COMMERCIAL LOCK

Insert the 5/16" X 1-3/8" long steel spacers and the outside lock handle thru the section. Secure the handle using (2) #10-24 X 1-3/4" slotted pan head screws. Assemble the rim cylinder and night latch as detailed. Slip the lock disk onto the square shank of the outside handle and secure with the tinnerman lock nut. Attach all remaining items as per the installation.

**NOTE:** Insert a 7/16" ID X 2" long pipe over the shank of the outside handle and pound on the tinnerman nut to secure parts.

Attach SIDE LOCK to the endstile using (4) 1/4-20 X 5/8" Self Drilling Screws.

### INSIDE SIDE LOCK

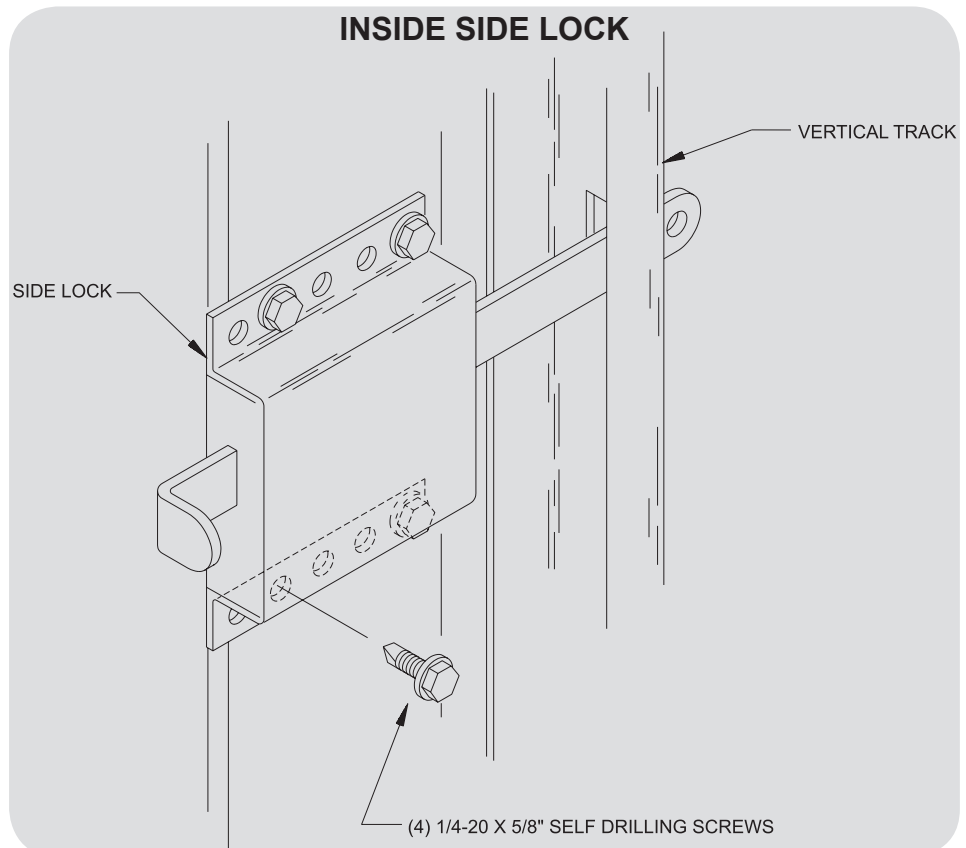

# LOW HEADROOM OUTSIDE HOOK-UP

## ► Step 3

### 2" TRACK BOTTOM BRACKETS

Secure cable to bottom brackets using 5/16" Diameter clevis pin, washer, and cotter pin as shown.

Bottom brackets are left and right. Secure each low headroom bottom bracket to the section using 1/4-20 X 5/8" Self Drilling Screws. Bottom Brackets may be of different designs depending on the door weight.

BB-12/2"LHR (used upto 600# balance weight)

BB-6/BB-7, 2" LHR (used over 600#)

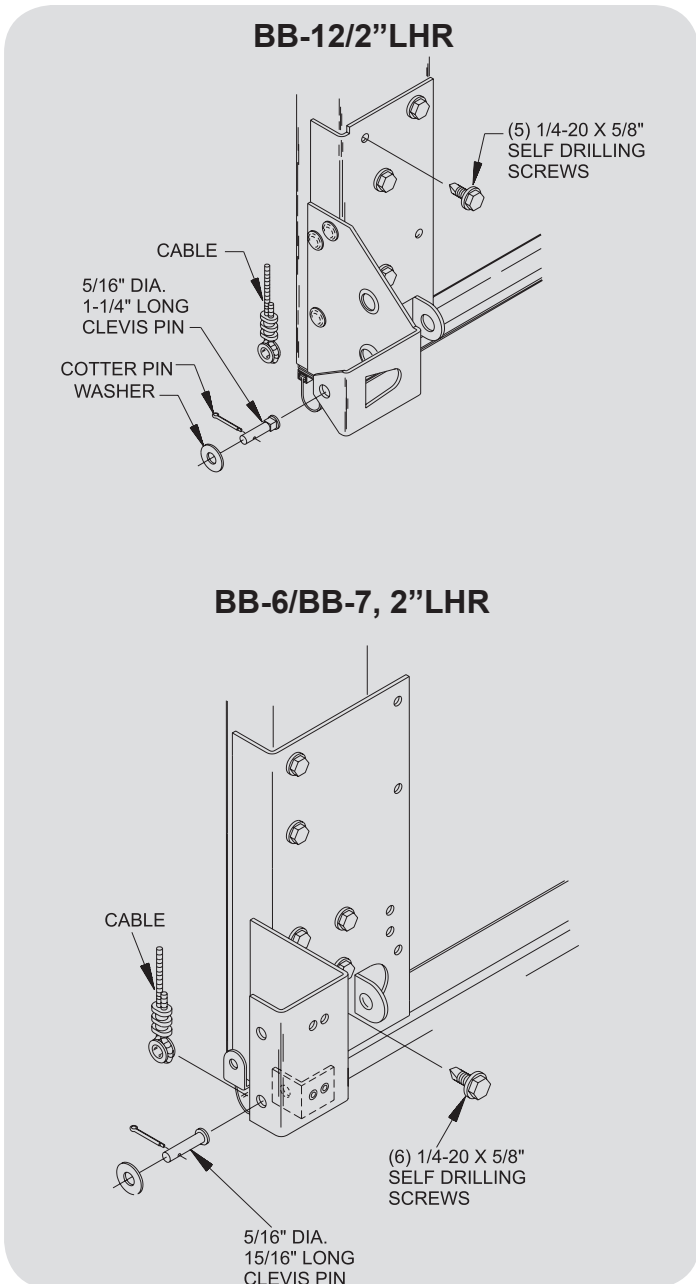

### 3" TRACK BOTTOM BRACKET

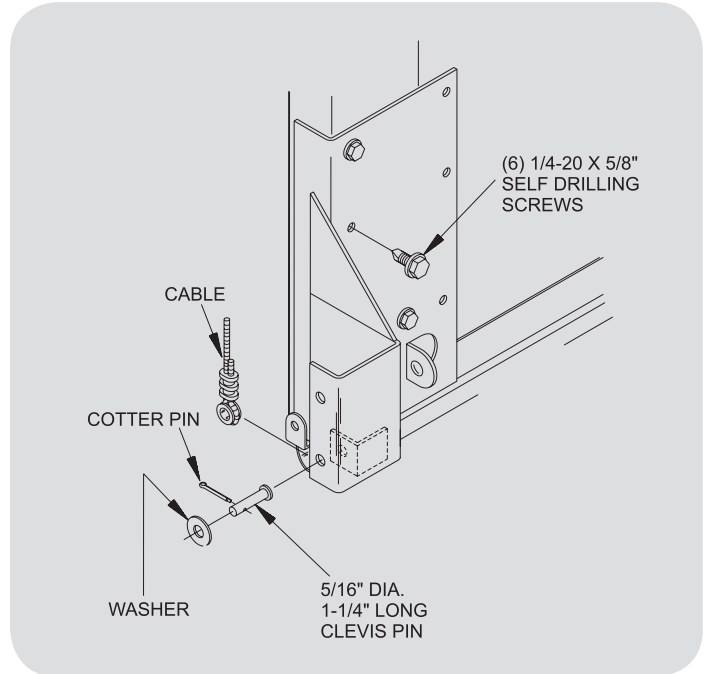

## ► Step 6

### PROVIDED ON 2" & 3" TRACK

Place a roller into the low headroom top bracket (7-4) and place onto the top section. Attach top bracket using (2) 1/4-20 X 3/4" Hex Head Bolts.

**NOTE: FOUR (4) TOP BRACKETS ARE PROVIDED ON ALL DOORS WITH DOUBLE ENDSTILES.**

