

Outside Disconnect For Doors With Trolley Operators Installation Instructions Insert

Wayne Dalton, a division of Overhead Door Corporation
P.O. Box 67, Mt. Hope, OH 44660
www.Wayne-Dalton.com

NOTE: Read installation instructions completely before starting to install the Outside Disconnect For Doors With Trolley Operators.

PARTS

NOTE: Door and trolley operator must be fully operational.

NOTE: Door and trolley operator must be in the fully closed position, prior to attaching outside disconnect to top section and trolley.

Verify that you have the correct parts as shown on the right.

1. #8-32 X 2 1/2" Carriage Bolts

(Quantity = 2)

2. #8-32 Hex Nuts

(Quantity = 2)

3. 1/2" Washers

(Quantity = 2)

4. Outside Disconnect Assembly

(Quantity = 1)

4a. S-Hook

(Quantity = 1)

4b. Cable

(Quantity = 1)

4c. Base

(Quantity = 1)

4d. Cylinder

(Quantity = 1)

5. Keys

(Quantity = 2)

6. Backup Plate

(Quantity = 1)

7. #8-15 X 1/2" Self-Tapping Screws

(Quantity = 2)

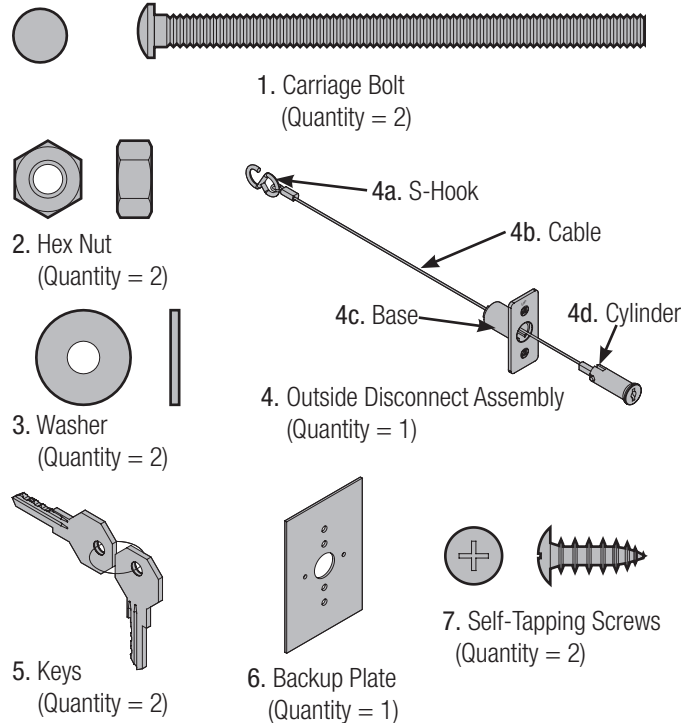

NOTE: Models 9100 and wood doors do not require these self-tapping screws.

NOTE: The backup plate and the two #8-15 X 1/2" self-tapping screws are not required on model 8000 doors.

STEP 1

FOR ALL MODELS, EXCEPT FOR THE 8000:

From the left hand side of top section on the inside of door, measure from the outside edge of the end stile to the outside edge of right hand end stile. Using that measurement, mark a vertical line onto the top section showing the center of the door. Now measure from the top edge of the top section to the bottom edge of the top section, to determine the center of the top section. Mark a horizontal line that intersects the vertical line previously made, as shown in **FIG. 1.1**.

IMPORTANT: THE VERTICAL MARK SHOWING THE CENTER OF DOOR SHOULD BE IN LINE WITH THE CENTER OF THE TROLLEY OPERATOR AND OPERATOR BRACKET.

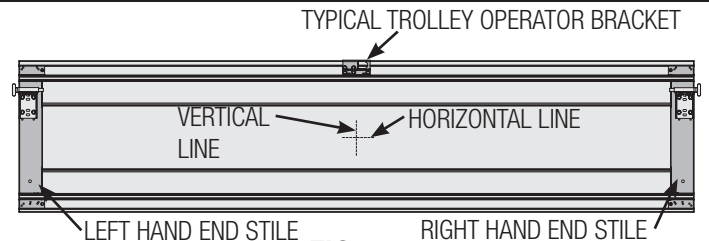

FIG. 1.1

STEP 1 - CONTINUED

Align the center hole of backup plate with the vertical and horizontal line intersecting with each other, as shown in **FIG. 1.2** and **1.3**. Hold the backup plate up against the top section and pencil mark the three vertical center holes, as shown in **FIG. 1.3**. Remove the backup plate from the top section and set aside.

FOR 8000 MODEL:

Starting at the center stile of top section and from the inside of door, measure between the large and small hole in the center of the center stile, to determine the center between the large and small hole. Mark a horizontal line at the point. Now measure from both edges of center stile and mark a vertical line onto the center stile, showing the center of the center stile, as shown in **FIG. 1.4**.

IMPORTANT: THE VERTICAL MARK SHOWING THE CENTER OF DOOR SHOULD BE IN LINE WITH THE CENTER OF THE TROLLEY OPERATOR AND OPERATOR BRACKET.

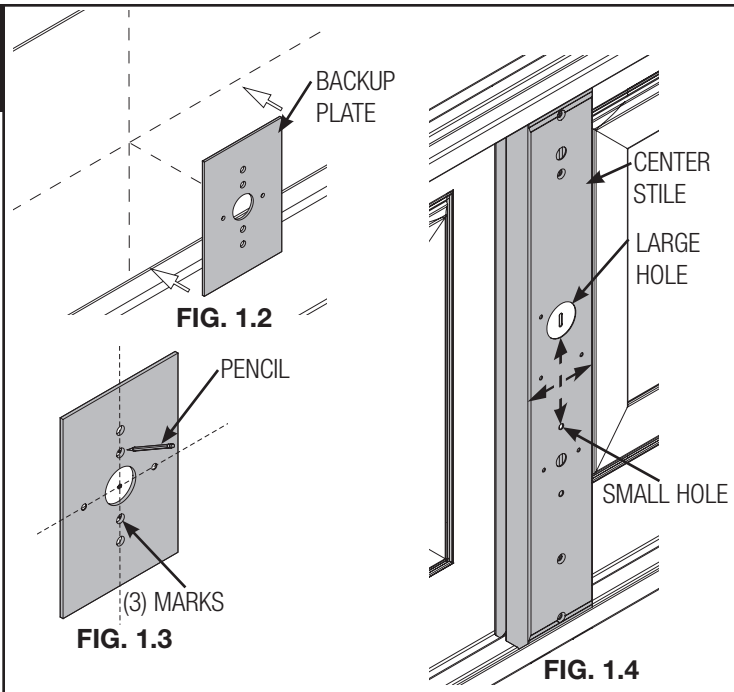

STEP 2

FOR ALL MODELS, EXCEPT FOR THE 8000:

From the inside of door, using a 3/16" drill bit, drill through the top section at the top and bottom marked hole locations (from **STEP 1**). Using a 3/4" drill bit, drill through the top section at the middle marked hole location (from **STEP 1**), as shown in **FIG. 2.1**. Remove any burrs or sharp edges from the drilled holes. Position the backup plate against the top section and align the three drilled holes with the corresponding holes in backup plate, as shown in **FIG. 2.2**. While holding the backup plate against the top section, secure it to the top section with (2) #8-15 X 1/2" self-tapping screws, as shown in **FIG. 2.3**.

NOTE: Models 9100 and Wood Doors do not require (2) #8-15 X 1/2" self-tapping screws.

FOR 8000 MODEL:

Starting where the lines intersect with each other, measure up 3/4" and make a horizontal mark across the vertical line. Measure down on the vertical line 3/4" and make a horizontal mark across the vertical line. You should now have intersecting lines that are 1 1/2" apart. Using a 3/16" drill bit, drill through end stile and face of section at each of the upper and lower marked hole locations. Using a 3/4" drill bit, drill through end stile and face of section at the middle marked hole location, as shown in **FIG. 2.4**. Remove any burrs or sharp edges from the drilled holes.

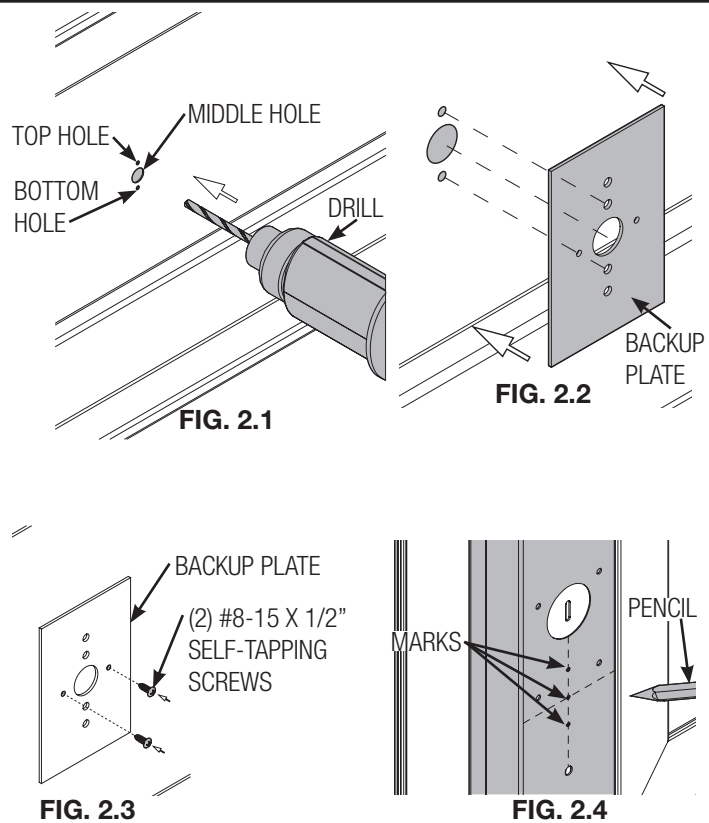

STEP 3

From the outside of door and holding the outside disconnect assembly, insert the s-hook into the middle pre-drilled hole (from **STEP 2**) of the top section and through the backup plate. Align the top and bottom holes in the base with the top and bottom pre-drilled holes (from **STEP 2**), as shown in **FIG. 3.1**. Slide the cylinder into the base, as shown in **FIG. 3.1**.

NOTE: There is no backup plate used on the **8000 Model**.

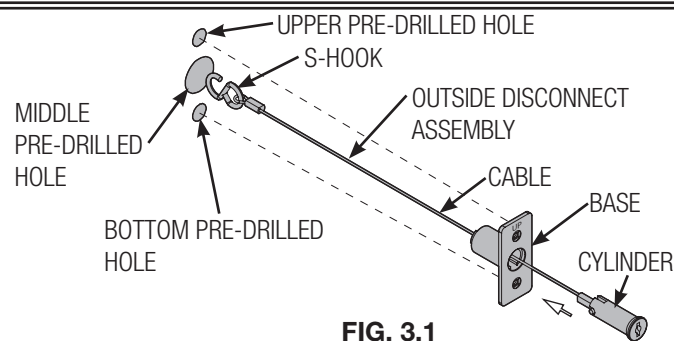

STEP 3 - CONTINUED

NOTE: Ensure the word “UP”, engraved on face of base, is pointing upwards when positioning base into top section.

From the outside of door, insert one #8-32 X 2 1/2” carriage bolt into the upper and lower holes of base, as shown in **FIG. 3.3** and **3.4**.

NOTE: (For Models 9100 and Wood Doors) From the inside of door, insert the s-hook through the middle hole of backup plate. Align the top and bottom holes in the backup plate with the (2) #8-32 X 2 1/2” carriage bolts and position it against the top section, as shown in **FIG. 3.4**.

From the inside of door, slide (1) 1/2” washer onto each of the #8-32 X 2 1/2” carriage bolts, as shown in **FIG. 3.5**. Secure the base to the backup plate with (2) #8-32 hex nuts, as shown in **FIG. 3.5** and **3.6**.

NOTE: If you have a model 8000 door, secure the outside disconnect assembly to the center stile with the same hardware as shown above, as shown in **FIG. 3.7**.

NOTE: You may need to cut off the protruding ends of the two #8-32 X 2 1/2” carriage bolts after securing the outside disconnect assembly to backup plate. If #8-32 X 2 1/2” carriage bolts are cutoff, use a file to smooth rough edges.

(2) #8-32 X 2 1/2”
CARRIAGE BOLTS

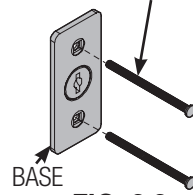

FIG. 3.3

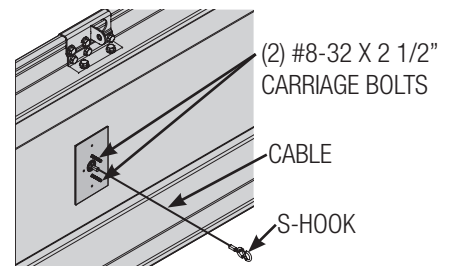

FIG. 3.4

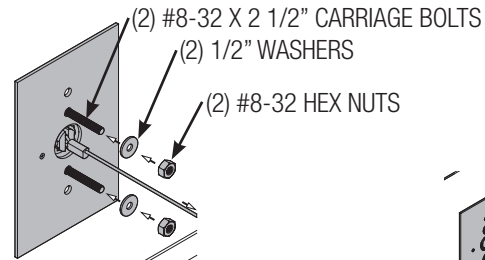

FIG. 3.5

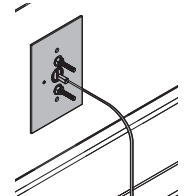

FIG. 3.6

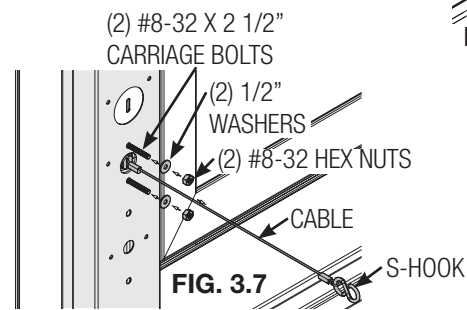

FIG. 3.7

STEP 4

Cut the red pull cord and remove it from the trolley catch (underneath the trolley rail), as shown in **FIG. 4.1**. Hook the s-hook from the outside disconnect assembly into the trolley catch, as shown in **FIG. 4.2**.

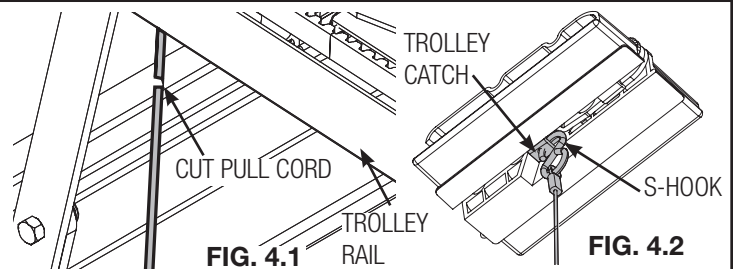

FIG. 4.1

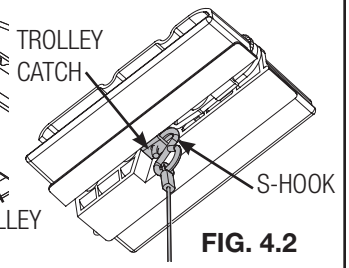

FIG. 4.2

STEP 5

1. Insert key into cylinder and turn counter clockwise, as shown in **FIG. 5.1**. Pull cylinder out of the base, as shown in **FIG. 5.2**.
2. Grasp cable and pull until tight. Lift door while pulling cable.
3. Replace cylinder into base, as shown in **FIG. 5.2** and turn key clockwise, as shown in **FIG. 5.1**. Remove key.

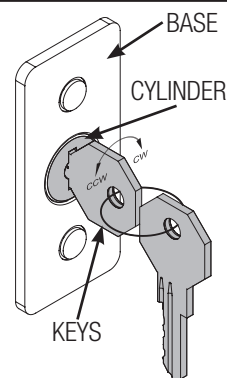

FIG. 5.1

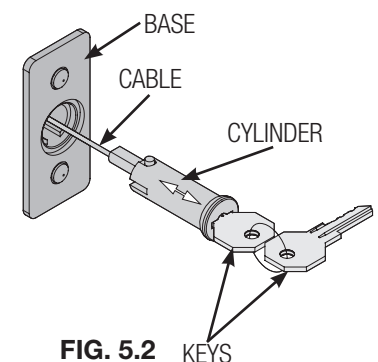

FIG. 5.2