

Modified Unilock

Installation Instructions and Owner's Manual

For All Residential and Commercial Doors
These Instructions are to be used in conjunction with the Installation Instructions And Owner's Manual.

www.Wayne-Dalton.com

BREAKDOWN OF PARTS

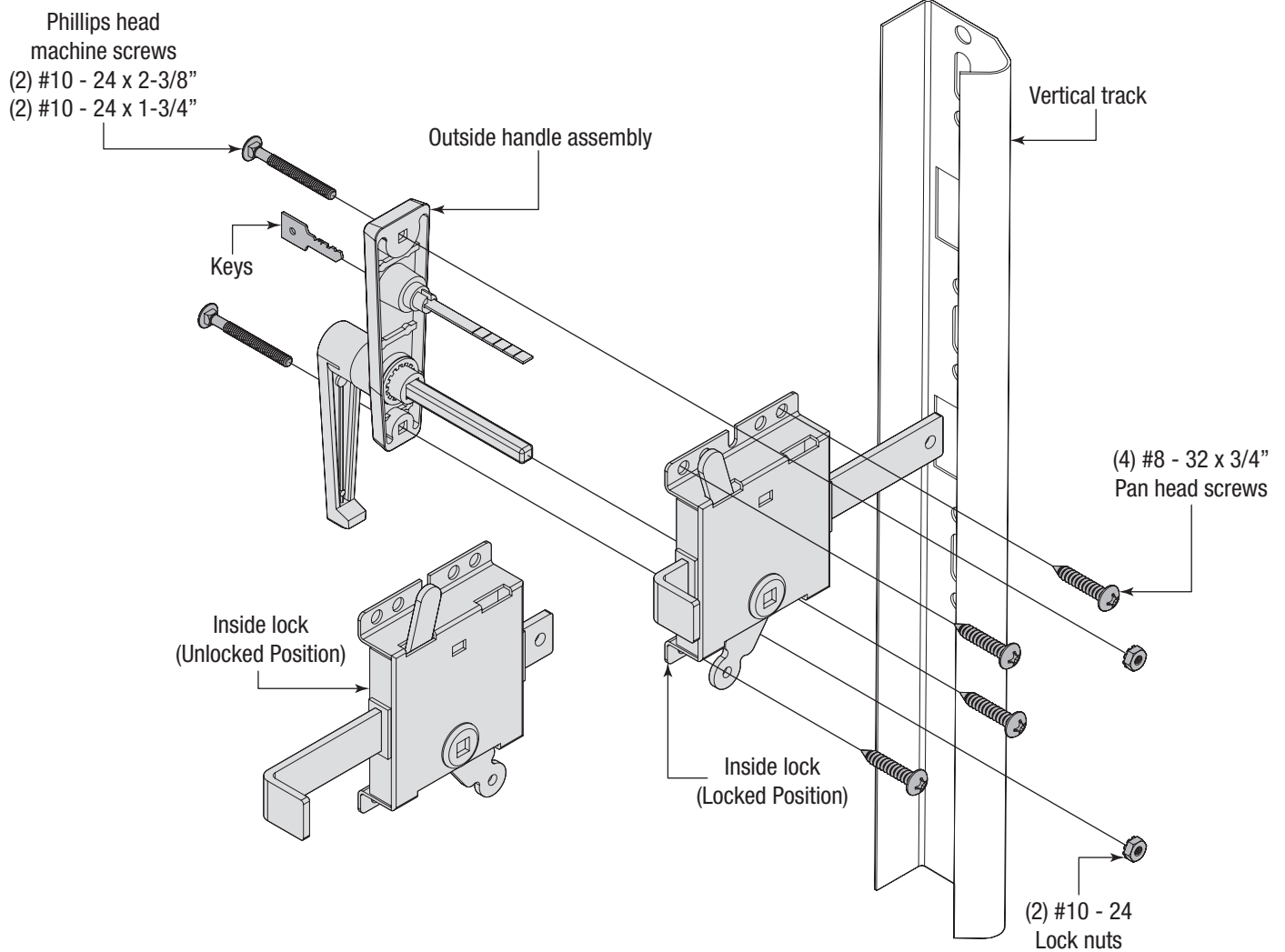

TOOLS REQUIRED:

- (1) Electric Drill
- (1) 1/8", 3/16", 5/16", 7/16", 5/8", 7/8" Drill Bits
- (1) 7/16" Wrench Or Socket
- (1) Phillips Screw Driver
- (1) Pencil or Marker
- (1) Tape Measure

IMPORTANT NOTICE! REFER TO THE DOOR MODEL INSTALLATION INSTRUCTIONS MANUAL FOR IMPORTANT SAFETY NOTICES.

INSTALLATION

1 Drilling Door Section

CAUTION

DO NOT DRILL DOOR SECTION OR INSTALL LOCK ON DOORS WITH OPENERS UNLESS AN ELECTRICAL INTERLOCK IS ALSO INSTALLED. THE DOOR AND/OR OPENER MAY BE DAMAGED IF THE OPENER IS USED WHILE THE DOOR IS LOCKED.

NOTE: Common practice is to mount the lock towards the right side of the door section from the inside looking out.

From the **INSIDE** of the door section, square the lock with the section and align the slide with the rectangular hole in the vertical track. The lock should be spaced approximately 1/8" in from the section edge. Place a mark at the top of the lock at the center of slot (as shown). Now, remove the lock and measure down 4-5/16" from the first mark. To insure marks are parallel with edge of the door, measure the distance from the edge of the door to the center of the first mark. Use this measurement to mark the center of the bottom mark.

NOTE: Ensure the dimension between the two marks is 4-5/16".

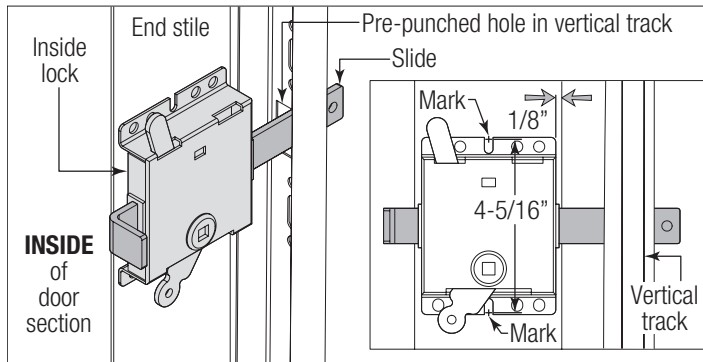

Drill 3/16" diameter hole straight through the entire section at each marked location.

CAUTION

BE CAREFUL TO KEEP DRILL STRAIGHT WHEN DRILLING. SECTION DAMAGE CAN RESULT FROM FAILURE TO KEEP THE DRILL STRAIGHT.

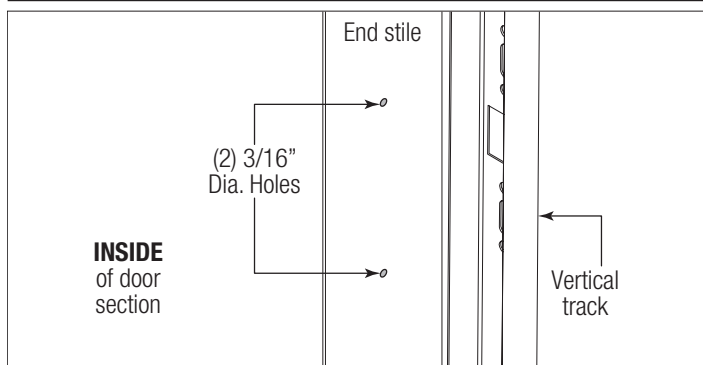

From the **INSIDE** of the door section, lightly draw a vertical line at the center of the two previously drilled holes. Using the illustration below, measure and mark two more locations onto the surface of the section. Drill the appropriate diameter holes straight through the entire section at each marked location.

CAUTION

BE CAREFUL TO KEEP DRILL STRAIGHT WHEN DRILLING. SECTION DAMAGE CAN RESULT FROM FAILURE TO KEEP THE DRILL STRAIGHT.

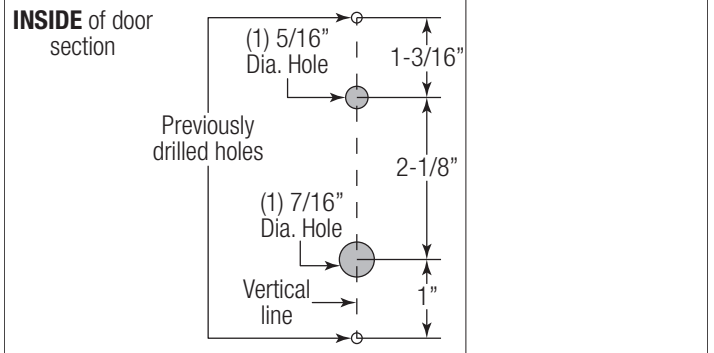

From the **OUTSIDE** of the door section enlarge the two previously drilled holes, paying close attention **NOT TO DRILL** completely through section.

NOTE: Do not drill through or enlarge holes in the end stile

CAUTION

BE CAREFUL TO KEEP DRILL STRAIGHT WHEN DRILLING. SECTION DAMAGE CAN RESULT FROM FAILURE TO KEEP THE DRILL STRAIGHT.

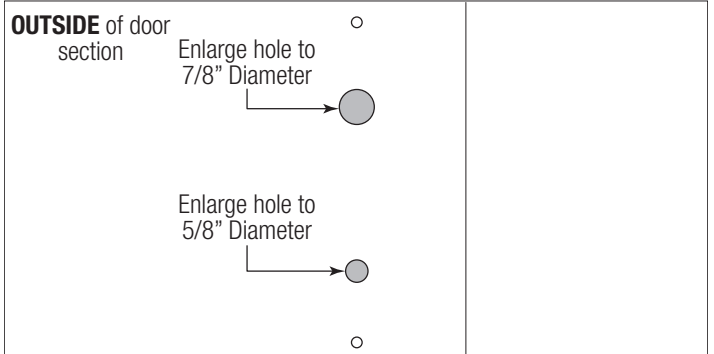

IMPORTANT: REMOVE ALL BURRS FROM THE DRILLED HOLES BEFORE PROCEEDING TO NEXT STEP.

2 Outside Handle Assembly Installation

From the **OUTSIDE** of the door section, align the outside handle assembly with the handle pointing towards the floor and insert the shank and stem through the previously drilled inner holes in the section.

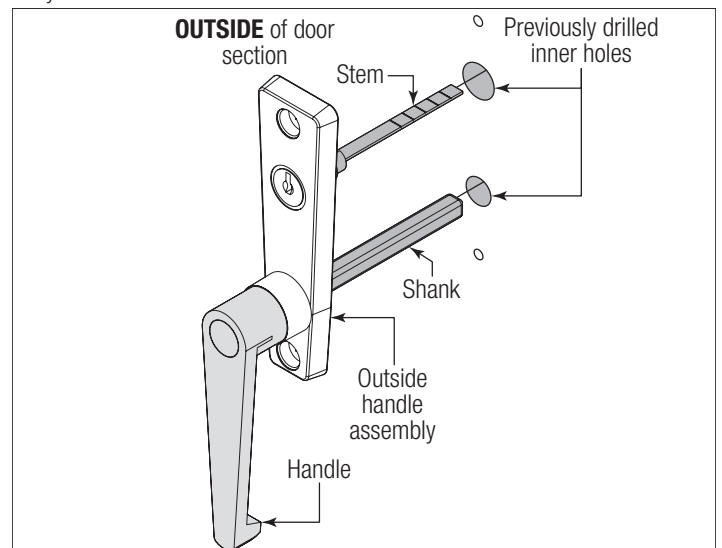

NOTE: Phillips head machine screws of two lengths (2-3/8" and 1-3/4") are provided. The correct length to use depends on your door thickness.

Insert the appropriate (2) #10 phillips head screws through the handle assembly and through the previously drilled outer holes.

NOTE: Turn the handle sideways prior to inserting the bottom #10 phillips head screw into the outside handle assembly.

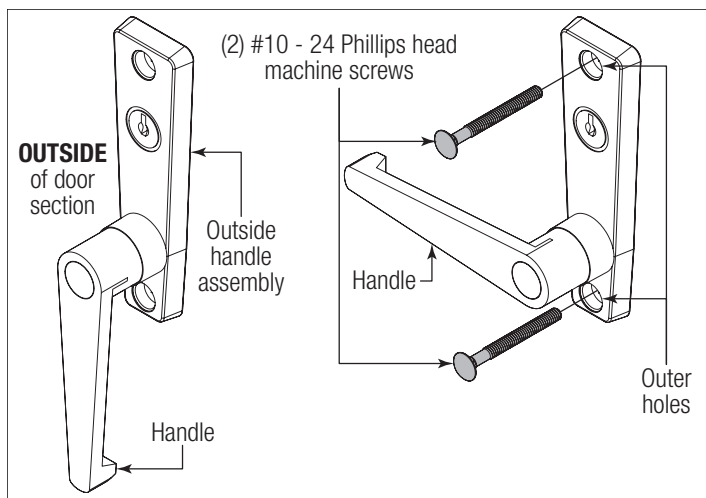

From the **INSIDE** of the door section, align the inside lock over the shank and stem. Hold the inside lock up against the section and mark four hole locations onto the section surface, as shown. Set the inside lock aside. Using a 1/8" drill bit, pilot drill 1" deep holes at each marked location.

NOTE: Do not drill through or enlarge holes on the inside of the door section.

CAUTION

BE CAREFUL TO KEEP DRILL STRAIGHT WHEN DRILLING. SECTION DAMAGE CAN RESULT FROM FAILURE TO KEEP THE DRILL STRAIGHT.

IMPORTANT: BE EXTREMELY CAREFUL NOT TO DRILL THRU THE DOOR SECTION. ONLY DRILL 1" DEEP.

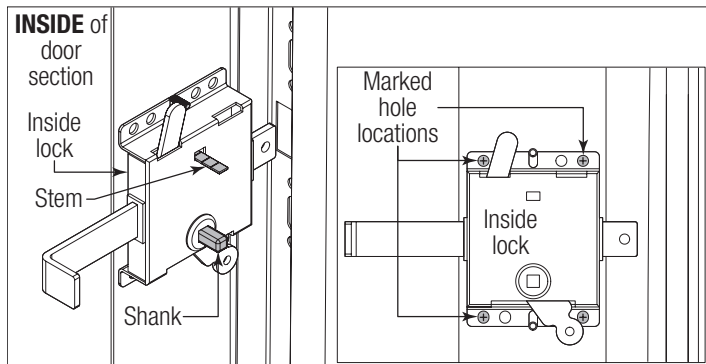

Reposition the inside lock up against the section and align the lock over the shank and stem. Secure both the outside handle assembly and the inside lock to the section using (2) #10 - 24 lock nuts.

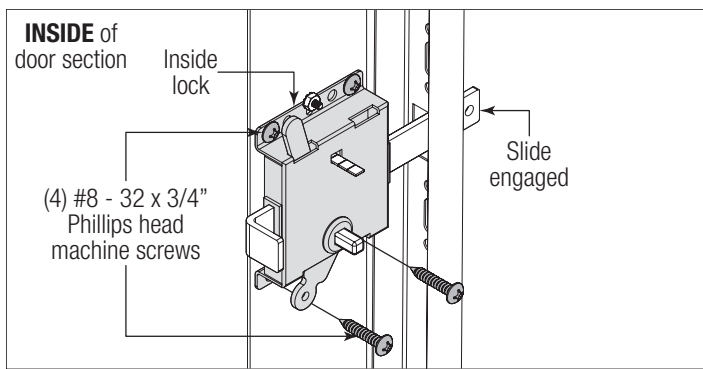
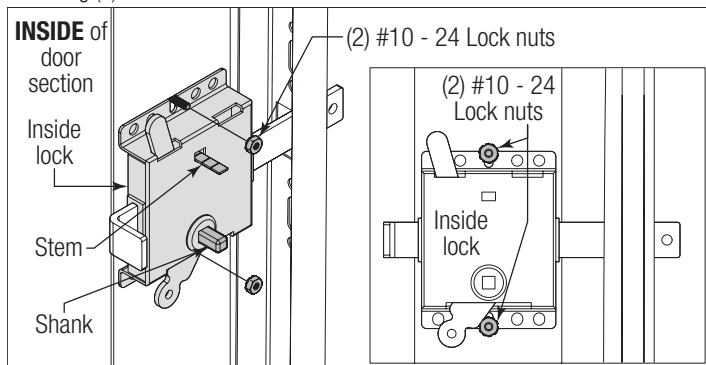

Operate your lock several times to make sure the slide clears the vertical track when door is unlocked and the slide engages the pre-punched hole in vertical track when door is locked. When the inside lock is properly installed, the door will be easy to use and will operate smoothly.

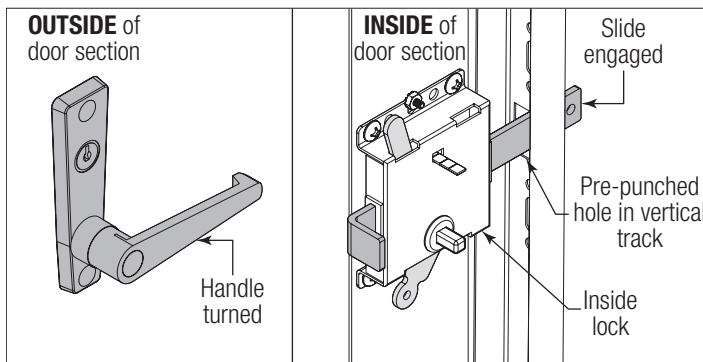
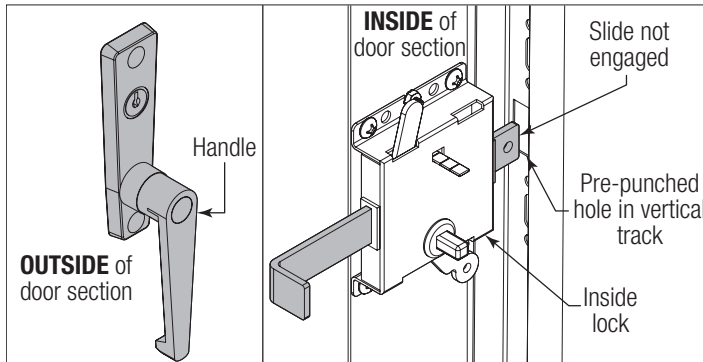

3 Inside Lock Installation

Secure the inside lock to the door section using (4) #8 - 3/4" pan head screws.

NOTE: Prior to installing the #8 - 3/4" pan head screws, pilot drill the hole locations using an 1/8" drill bit.