

LOW HEADROOM EXTENSION

Supplemental insert

©Copyright 2016 Wayne Dalton, a division of Overhead Door Corporation

Part No. 333897

REV3 5/03/2016

This supplemental installation instruction is to be used as a supplement to the main Installation Instruction and Owner's Manual provided with the door. The instructions included in this document are ONLY those which deviate from the standard installation. All WARNINGS and CAUTIONS listed in the main manual are applicable to this supplemental instruction as well.

www.Wayne-Dalton.com

INSTALLATION

1

Cutting Vertical Track

Vertical track must be cut to the proper length prior to installation.

IMPORTANT: DOORS THAT ARE 7'-0" OR 8'-0" IN HEIGHT DO NOT REQUIRE CUTTING THE VERTICAL TRACK.

Determine the radius of your horizontal track. Using this measurement, refer to the vertical track cutting chart to determine the length of the vertical track. Cut the track off at the TOP. Two holes must be drilled into the top of the cut vertical track. Refer to the illustration shown for hole locations. Use a 5/16" drill bit, as shown in FIG. 1.1.

Vertical Track Cutting Chart

Horizontal Track Radius	Vertical Track Cut Length
0" Rad	Door Height Minus 17"
12" Rad (3-1/2" LHR)	Door Height Minus 15"
14" Rad (6-1/2" LHR)	Door Height Minus 12"

Repeat for other vertical track.

2

Quick Install Jamb Brackets

NOTE: If you do not have quick install jamb brackets, skip this step and complete fully adjustable jamb brackets on page 2.

Using the measurement from QUICK INSTALL JAMB BRACKET CHART, measure the length of the vertical tracks to determine the placement of the quick install jamb brackets. To install the jamb brackets, align the twistlock tab on the quick install jamb bracket with the quick install feature in the track and turn the bracket perpendicular to the track so the mounting flange is toward the back (flat) leg of the track, as shown in FIG. 2.1.

NOTE: Jamb brackets are stamped for identification.

QUICK INSTALL JAMB BRACKET CHART

DOOR HEIGHT	1ST SET		3RD SET		4TH SET	
	JAMB BKT	POS.	JAMB BKT	POS.	JAMB BKT	POS.
6'0"	QIJB - 3	MIDDLE	QIJB - 6	TOP	NOT APPLICABLE	
6'5"	QIJB - 3	MIDDLE	QIJB - 5	BOTTOM	NOT APPLICABLE	
6'8"	QIJB - 3	MIDDLE	QIJB - 5	BOTTOM	NOT APPLICABLE	
7'0"	QIJB - 3	MIDDLE	QIJB - 5	BOTTOM	NOT APPLICABLE	
7'3"	QIJB - 3	MIDDLE	QIJB - 5	MIDDLE	QIJB - 6	MIDDLE
7'6"	QIJB - 3	MIDDLE	QIJB - 5	MIDDLE	QIJB - 6	MIDDLE
8'0" 4 SECT.	QIJB - 3	MIDDLE	QIJB - 5	MIDDLE	QIJB - 6	MIDDLE
8'0" 5 SECT.	QIJB - 3	BOTTOM	QIJB - 5	BOTTOM	QIJB - 6	BOTTOM

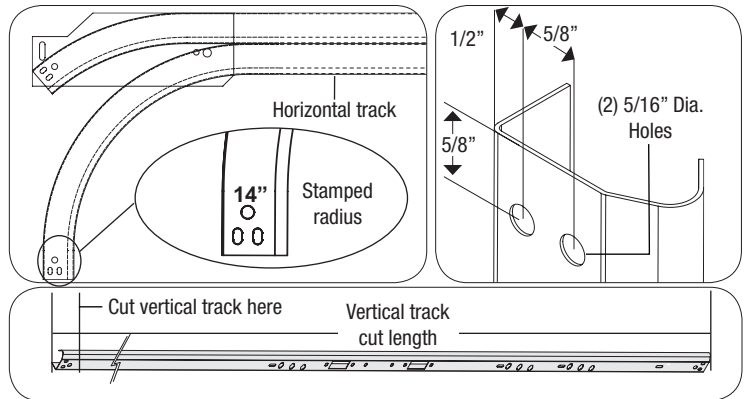

FIG. 1.1

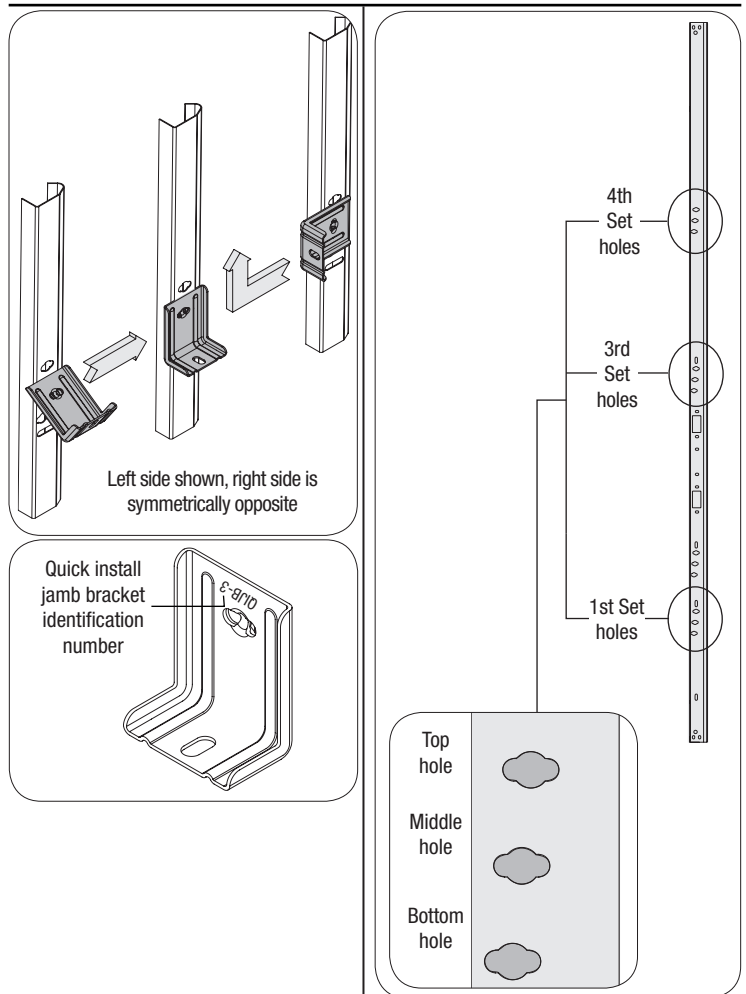

FIG. 2.1

Fully Adjustable Jamb Brackets

NOTE: If quick install jamb brackets were installed, skip this step and continue with horizontal track installation. If not, complete this step.

The bottom jamb bracket is always the shortest bracket included with your door. To attach the bottom jamb bracket, locate the first set of quick install features of the vertical track. Align the slot in the jamb bracket with the slot above the quick install features in the vertical track. The long side of the bracket is placed against the track and with the tabs away from the track. Fasten the jamb bracket finger tight, using (1) 1/4" - 20 x 5/8" track bolt and (1) 1/4" - 20 flange hex nut. To attach the top jamb bracket, locate the third set of quick install features of the vertical track. Align the slot in the jamb bracket with the slot above the quick install features in the vertical track. The long side of the bracket is placed against the track. Fasten the jamb bracket finger tight, using (1) 1/4" - 20 x 5/8" track bolt and (1) 1/4" - 20 flange hex nut, as shown in **FIG. 3.1**.

Repeat for other vertical track.

NOTE: The jamb bracket fasteners are to be tightened when the vertical track is secured to the jamb.

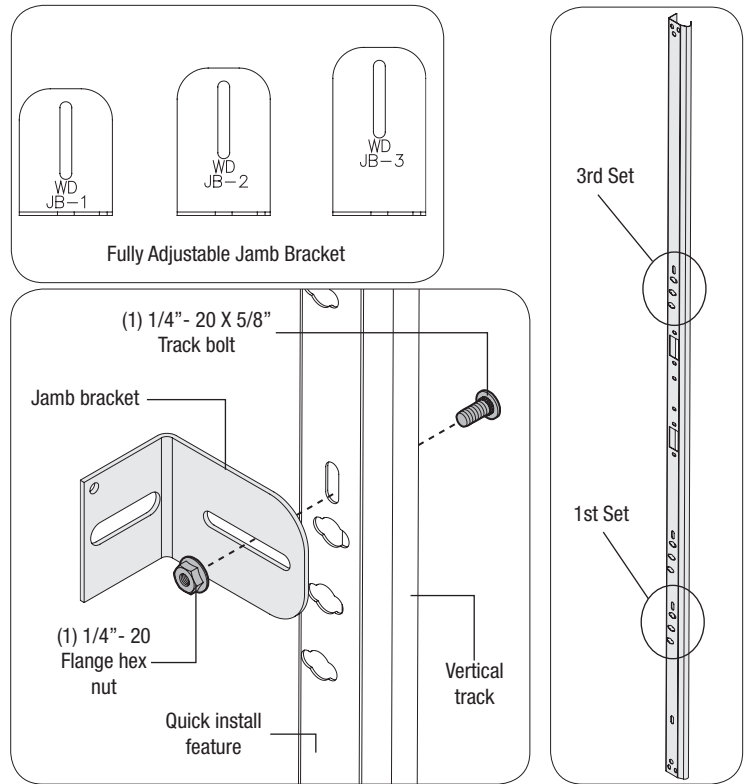

FIG. 3.1

Universal Horizontal Track Installation

Place the horizontal track overtop of the previously installed vertical track. Align the bottom of the horizontal track with the top of the vertical track.

Secure the horizontal track to the corresponding flagangle with (2) 1/4" - 20 x 5/8" carriage bolts and nuts. Level the horizontal track and secure the upper curve to the flagangle using (1) 3/8" - 16 x 3/4" Hex Head Bolt, and (1) 3/8" - 16 hex nut, as shown in **FIG. 4.1**.

NOTE: If an idrive[®] opener will be installed, position horizontal tracks slightly above level.

Repeat for other side.

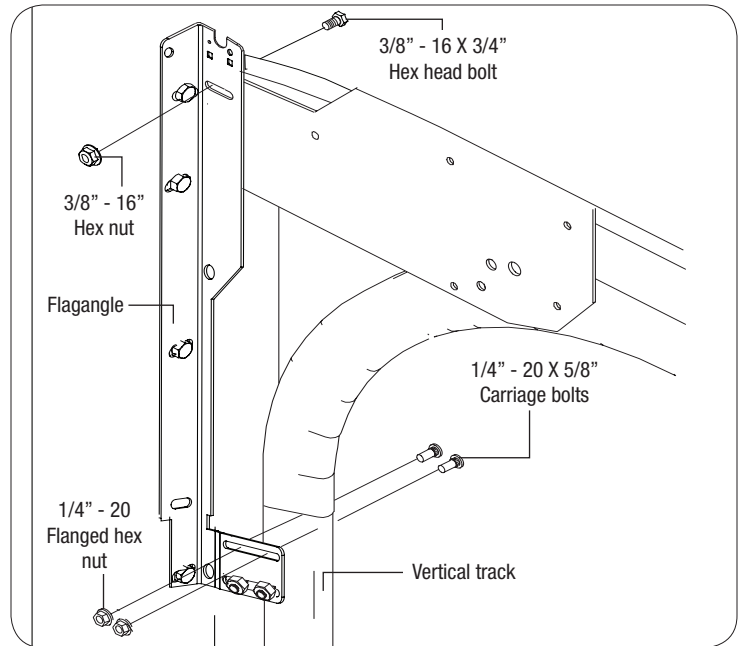

FIG. 4.1

Bottom Bracket Installation

Identify the low-headroom bottom brackets provided with your door (**A, B or C**). Place them, left and right onto the bottom corners of the section. Seat the bottom brackets against the edge of the section, as shown in **FIG. 5.1** and **5.2**.

FOR LOW HEADROOM BOTTOM BRACKET (A):

Secure the low headroom bottom bracket to the section with four 1/4" - 20 x 11/16" self drilling screws, as shown in **FIG. 5.1**.

Place roller into holes of each bottom bracket, as shown in **FIG. 5.1**.

NOTE: (For dealer use only) Install one additional 1/4" - 14 x 5/8" tamper resistant screw, as shown in **FIG. 5.1**.

FOR LOW HEADROOM BOTTOM BRACKET (B):

Secure the low headroom bottom bracket to the section with four 1/4" - 20 x 2 1/2" carriage bolts and four 1/4" - 20 flange hex nuts, as shown in **FIG. 5.2**.

Place roller into holes of each bottom bracket, as shown in **FIG. 5.2**.

NOTE: (For dealer use only) Install one additional 1/4" - 14 x 5/8" tamper resistant screw, as shown in **FIG. 5.2**.

FOR LOW HEADROOM BOTTOM BRACKET (C):

Secure the low headroom bottom bracket to the section with four 1/4" - 20 x 11/16" self drilling screws, as shown in **FIG. 5.3**.

NOTE: (For dealer use only) Install one additional 1/4" - 14 x 5/8" tamper resistant screw, as shown in **FIG. 5.3**.

Attach the counter balance cable to the low-headroom bottom brackets using clevis pins. Secure the clevis pins to bottom brackets using a 5/16" flat washer and cotter pin, as shown in **FIG. 5.4**.

NOTE: Place roller into the factory attached bottom brackets, as shown in **FIG. 5.5**.

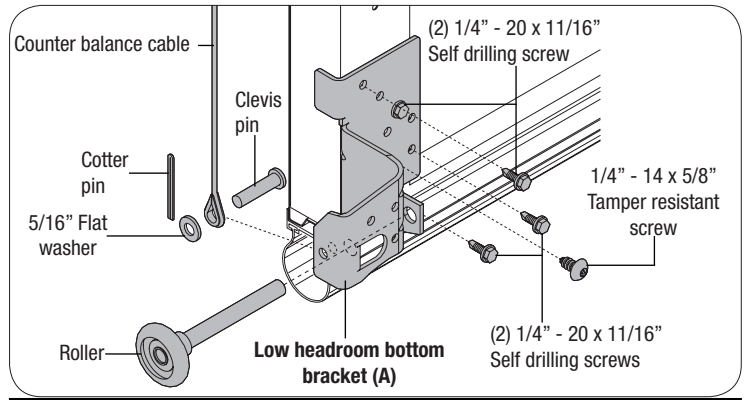

FIG. 5.1

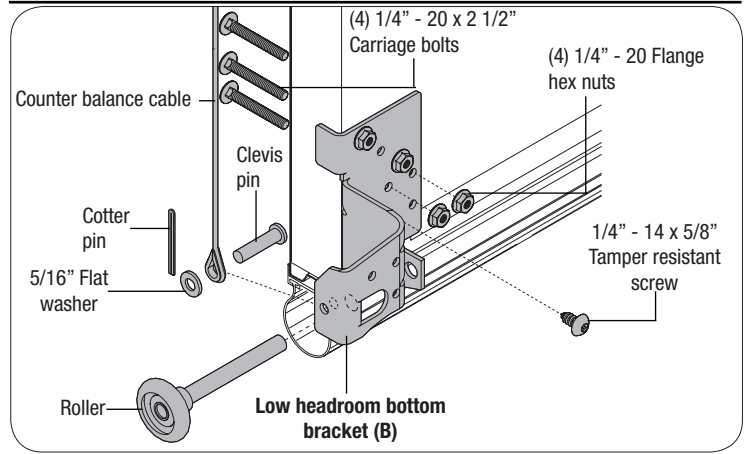

FIG. 5.2

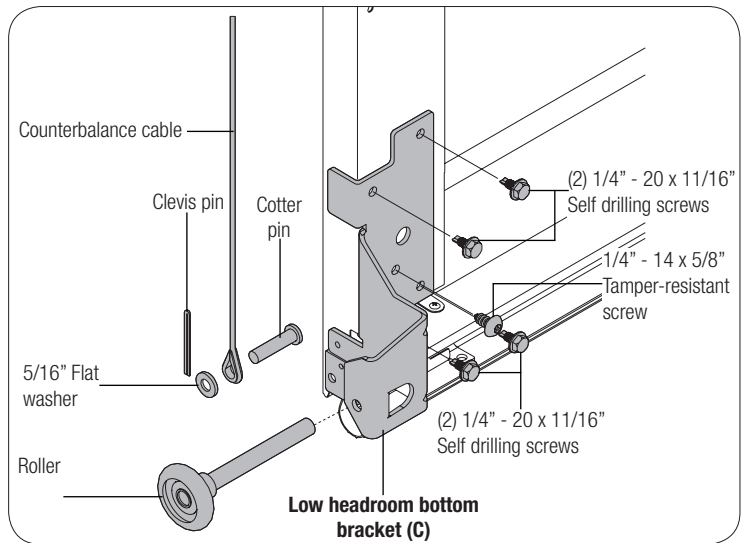

FIG. 5.3

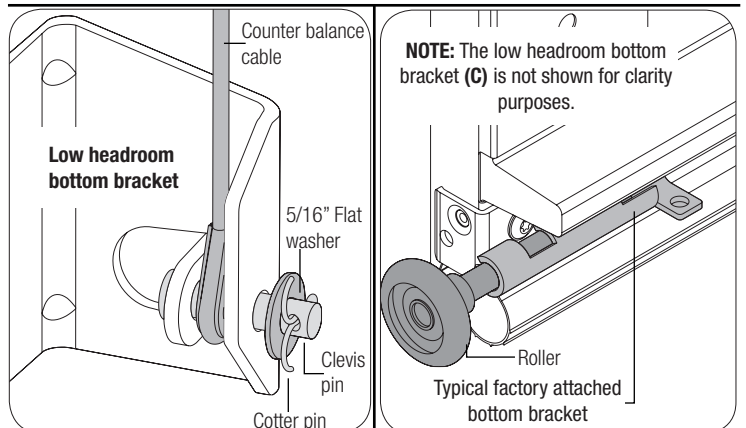

FIG. 5.4

FIG. 5.5

Low Headroom Top Bracket

Identify the low-headroom top brackets provided with your door (**A, B, C or D**). Push the top section of door out against the jamb until the section is parallel with the other sections of the door. Starting with the left hand side, align the edge of top bracket with the edge of section.

NOTE: When installing the top brackets, the top section must be vertically aligned with the rest of the sections from the side view. If needed reposition top bracket(s) to achieve vertical alignment.

FOR LOW HEADROOM TOP BRACKET (A):

Secure the low headroom top bracket to the section by placing one 1/4" - 20 x 11/16" self drilling screw through the lower slot of bracket. Adjust the low headroom top bracket if necessary and secure two more 1/4" - 20 x 11/16" self drilling screws through the top holes, as shown in **FIG. 6.1**.

Repeat the same process for the other side.

FOR LOW HEADROOM TOP BRACKET (B) OR (C):

NOTE: The LHR top bracket comes pre-assembled, as shown in **FIG. 6.3** or **FIG. 6.4**. Locate the edge of the top section and seat the top bracket on male part of the top section, as shown in **FIG. 6.2**.

Attach the top bracket to the top section (B):

1. Attach one 1/4" - 20 x 11/16" self-drilling screw to the top bracket assembly.
2. Attach two 1/4" - 20 x 11/16" self-drilling screws to the top bracket assembly.
3. Attach two #12 x 1/2" phillips head screws on the opposite side of top bracket assembly.

Insert a roller into the top bracket slide, as shown in **FIG. 6.3**. Repeat the same process for the other side.

Attach the top bracket to the top section (C):

1. Attach one 1/4" - 14 x 5/8" self-tapping screw to the top bracket assembly.
2. Attach two 1/4" - 20 x 11/16" self-drilling screws to the top bracket assembly.
3. Attach two #12 x 1/2" phillips head screws on the opposite side of top bracket assembly.

Insert a roller into the top bracket slide, as shown in **FIG. 6.4**. Repeat the same process for the other side.

REVERSING THE TOP SLIDE (B) OR (C), IF NEEDED:

NOTE: Depending on your application, you may need to reverse the top bracket slide for more adjustment, if needed, prior to securing it to the top bracket base. Remove the top bracket slide by removing the two 1/4" - 20 x 5/8" carriage bolts, two retention washers and two 1/4" - 20 flanged hex nuts. Flip the top bracket slide in the opposite direction. Loosely fasten the top bracket slide to the bracket using two 1/4" - 20 x 5/8" carriage bolts, two retention washers and two 1/4" - 20 flanged hex nuts, as shown in **FIG. 6.5** or **FIG. 6.6**.

NOTE: The retention washers must be fully seated against the top bracket base to ensure the anti-twist feature on the top bracket slide engages in the slotted hole in the top bracket base.

FOR LOW HEADROOM HORIZONTAL TRACK (D):

NOTE: This is a traditional low headroom windload top bracket.

Vertically align the flat portion of roller slide with the endcap and u-bar at the top of top section. Fasten roller slide using (2) 1/4" - 14 x 7/8" self drilling screws, as shown in **FIG. 6.7**. Repeat the same process for the other side.

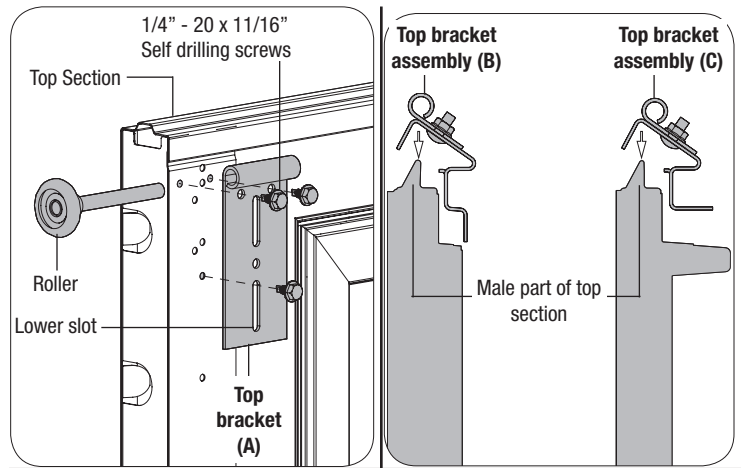

FIG. 6.1

FIG. 6.2

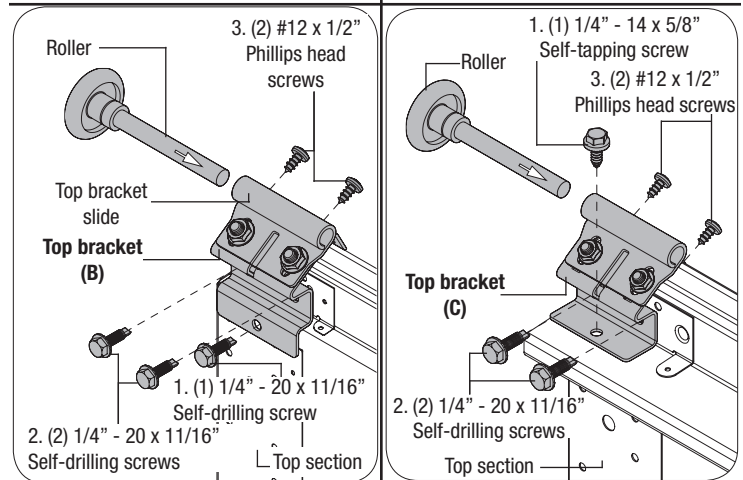

FIG. 6.3

FIG. 6.4

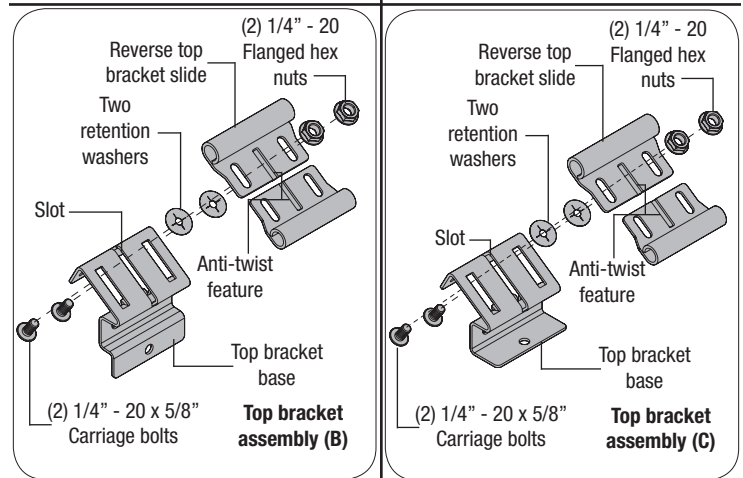

FIG. 6.5

FIG. 6.6

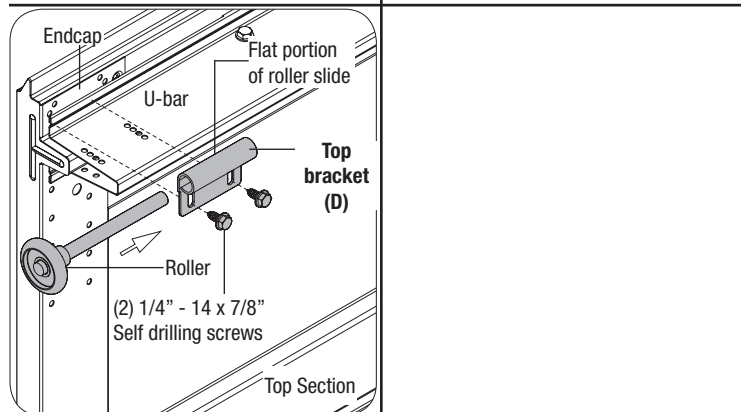

FIG. 6.7

WARNING

DO NOT RAISE DOOR UNTIL HORIZONTAL TRACKS ARE SECURED AT REAR, AS OUTLINED IN REAR SUPPORT INSTALLATION, OR DOOR COULD FALL FROM OVERHEAD POSITION CAUSING SEVERE OR FATAL INJURY.

7

Quick Install Horizontal Track Installation

Place the horizontal tracks over the top of the previously installed vertical tracks as shown. Locate the keyslot in the track over the Twistlock® tabs on the flagangles. Hold the parts together and tap down on the track to lock into place.

Place (1) 1/4-20 x 9/16" track bolt through the slot in the end of the top curve and the appropriate slot in the flagangle, then secure with a 3/8" flat washer and flanged hex nut (do not fully tighten). Level the horizontal track, then tighten the bolt in the top curve, as shown in **FIG. 7.1**.

For 1" x 4" x 23" angles, refer to that specified step.

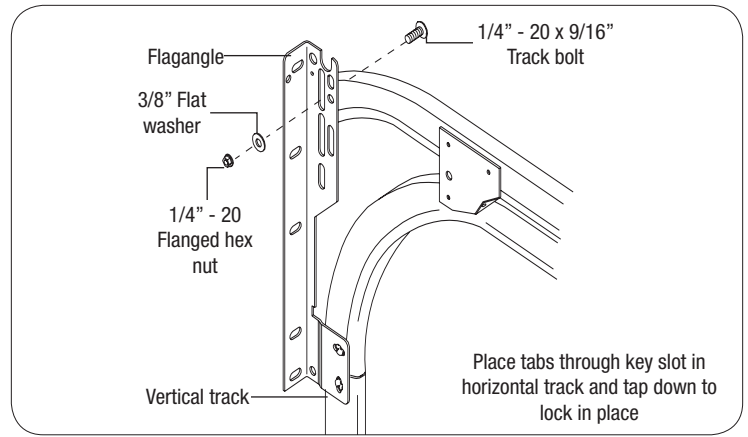

FIG. 7.1

8

Universal Horizontal Track Installation

Place the horizontal tracks over the top of the previously installed vertical tracks as shown. Attach the bottom of the lower curve to the flagangle using (1) stud plate and (2) nuts.

Place (1) 1/4-20 x 9/16" track bolt through the slot in the end of the top curve and the appropriate slot in the flagangle, then secure with a 5/16" flat washer and flanged hex nut (do not fully tighten). Level the horizontal track, then tighten the bolt in the top curve, as shown in **FIG. 8.1**.

For 1" x 4" x 23" angles, refer to that specified step.

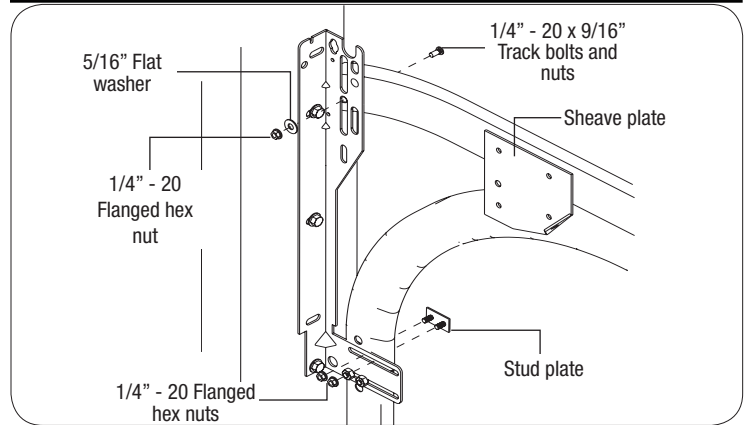

FIG. 8.1

9

Quick Install and Universal Horizontal Track Installation for 1" x 4" x 23" Angle

Place the horizontal tracks over the top of the previously installed vertical tracks shown in the Quick Install Horizontal Track Install step. Locate the keyslot in the track over the Twistlock® tabs on the flagangles. Hold the parts together and tap down on the track to lock into place.

Place the horizontal tracks over the top of the previously installed vertical tracks shown in the Universal Horizontal Track Install step. Attach the bottom of the lower curve to the flagangle using (2) 1/4-20 track bolts and nuts. Secure the upper curve to the flagangle using (1) 1/4-20 x 9/16" track bolt, 3/8" flat washer and flanged hex nut as illustrated.

Secure 1" x 4" x 23" horizontal angle to the flag angle with (1) 3/8 x 3/4" truss head bolt and nut, as shown in **FIG. 9.1**.

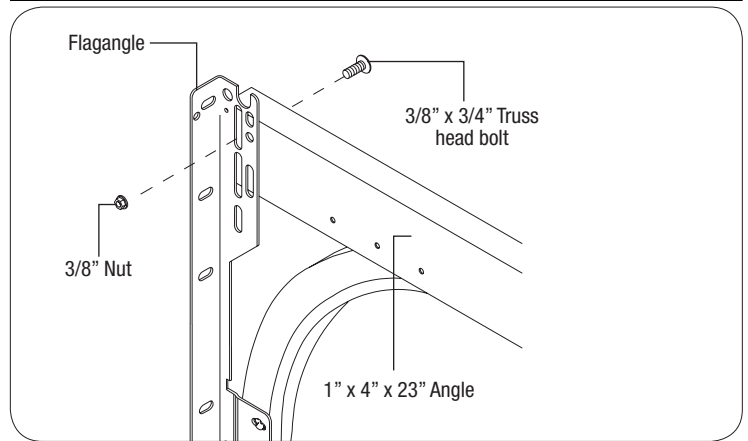

FIG. 9.1

10

Portland Universal Horizontal Track Installation

Place the horizontal tracks over the top of the previously installed vertical tracks as shown. Attach the bottom of the lower curve to the flagangle using (1) stud plate and (2) nuts.

Place (1) 1/4-20 x 9/16" track bolt through the slot in the end of the top curve and the appropriate slot in the flagangle, then secure with a 5/16" flat washer and flanged hex nut (do not fully tighten). Level the horizontal track, then tighten the bolt in the top curve, as shown in **FIG. 10.1**.

For 1" x 4" x 23" angles, refer to that specified step.

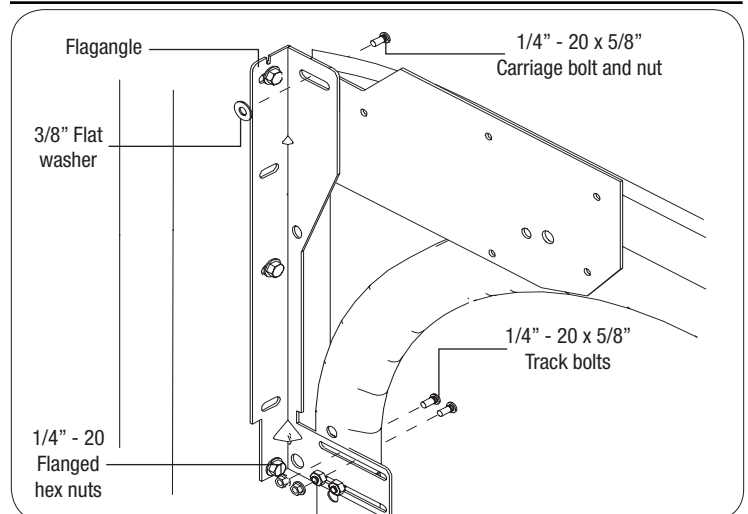

FIG. 10.1

11

Cable Sheave Installation

Identify the type of horizontal track that was provided with your door (**A or B**).

FOR HORIZONTAL TRACK (A):

Secure the studded sheave to the hole shown using (1) 3/8" hex nut. Repeat for the other side, then loop the counterbalance cables over each sheave, as shown in **FIG. 11.1**.

FOR HORIZONTAL TRACK (B):

Using the appropriate hole in the sheave plate as a guide, drill a 13/32" dia. hole through the sheave plate and track (see Figure). Place a 3/8-16 x 1-1/2" truss head bolt through the drilled hole and slide a steel sheave over the end of the bolt as shown. Secure the sheave using (1) 3/8" hex nut. Repeat for the other side, then loop the counterbalance cables over each sheave, as shown in **FIG. 11.2**.

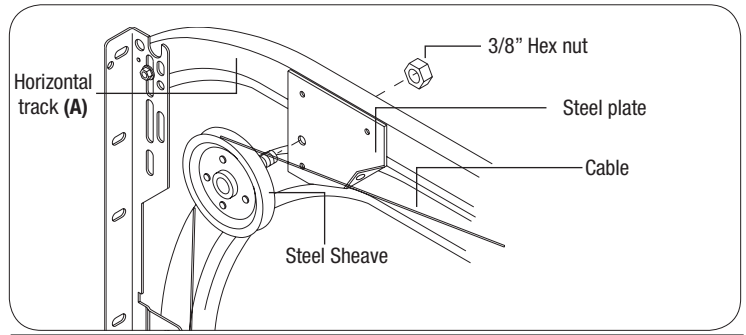

FIG. 11.1

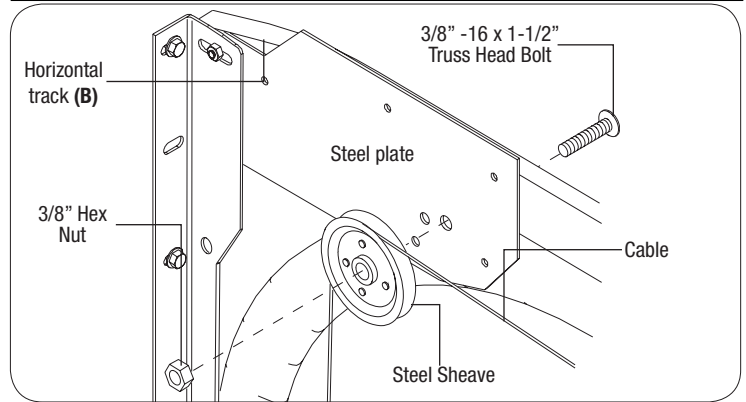

FIG. 11.2

12

Rear Support Installation

Raise the door until the top section and half of the next section are in a horizontal position. Do not raise door any further since rear of horizontal track is not yet supported.

⚠ WARNING

RAISING DOOR FURTHER CAN RESULT IN DOOR FALLING AND CAUSE SEVERE OR FATAL INJURY.

Clamp a pair of vice clamps on the vertical tracks just above the second roller on one side, just below the second roller on the other side. This will prevent the door from raising or lowering while installing the rear support. Using perforated angle, 5/16" x 1-5/8" hex head lag screws and 5/16" bolts with nuts (may not be supplied), fabricate rear support for horizontal tracks.

Attach horizontal tracks to the rear supports with 5/16"- 18 x 1-1/4" hex bolts and nuts (may not be supplied). Horizontal tracks must be level and parallel to door within 3/4" - 7/8" maximum of door edge, as shown in **FIG. 12.1** through **FIG. 12.3**.

⚠ WARNING

KEEP HORIZONTAL TRACK PARALLEL AND WITHIN 3/4" - 7/8" MAXIMUM OF DOOR EDGE, OTHERWISE DOOR COULD FALL, RESULTING IN SEVERE OR FATAL INJURY .

IMPORTANT: DO NOT SUPPORT THE WEIGHT OF THE DOOR ON ANY PART OF THE HORIZONTAL TRACK HANGER THAT CANTILEVERS 4" OR MORE BEYOND A SOUND FRAMING MEMBER.

NOTE: If rear supports are to be installed over drywall, use 5/16" x 2" hex head lag screws, and make sure lag screws engaged solid structural lumber.

NOTE: If an idrive[®] opener is installed, position horizontal tracks one hole above level when securing it to rear supports.

NOTE: 26" angle must be attached to sound framing members and nails should not be used.

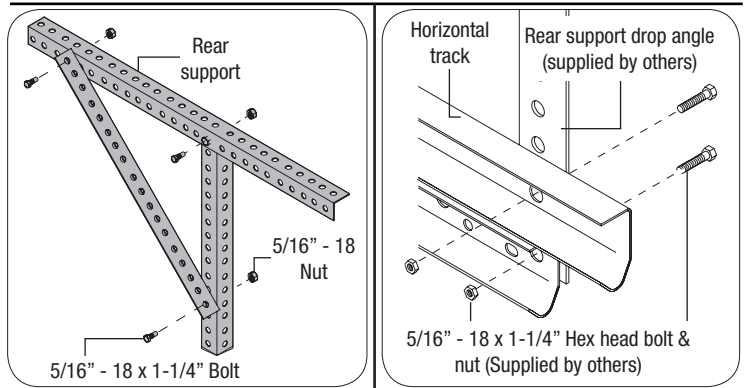

FIG. 12.1

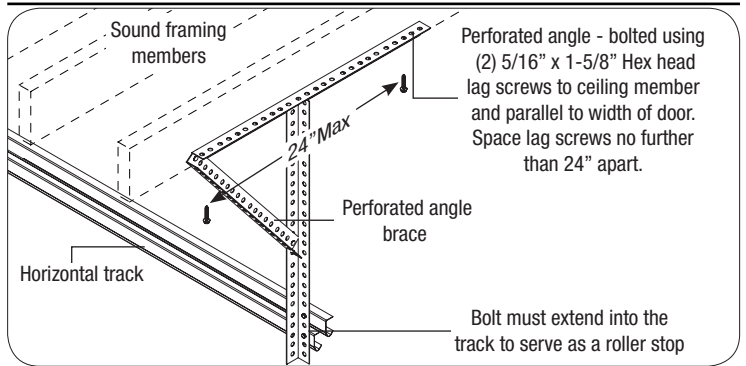

FIG. 12.2

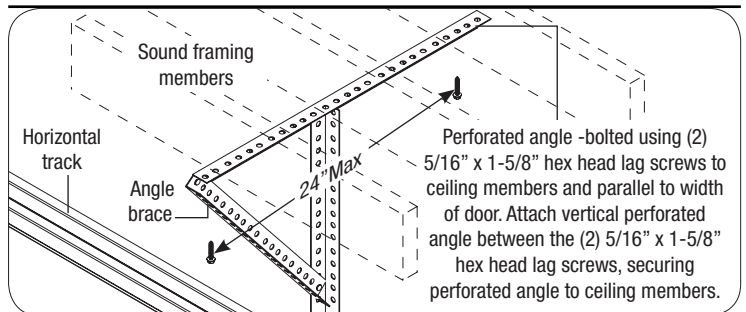
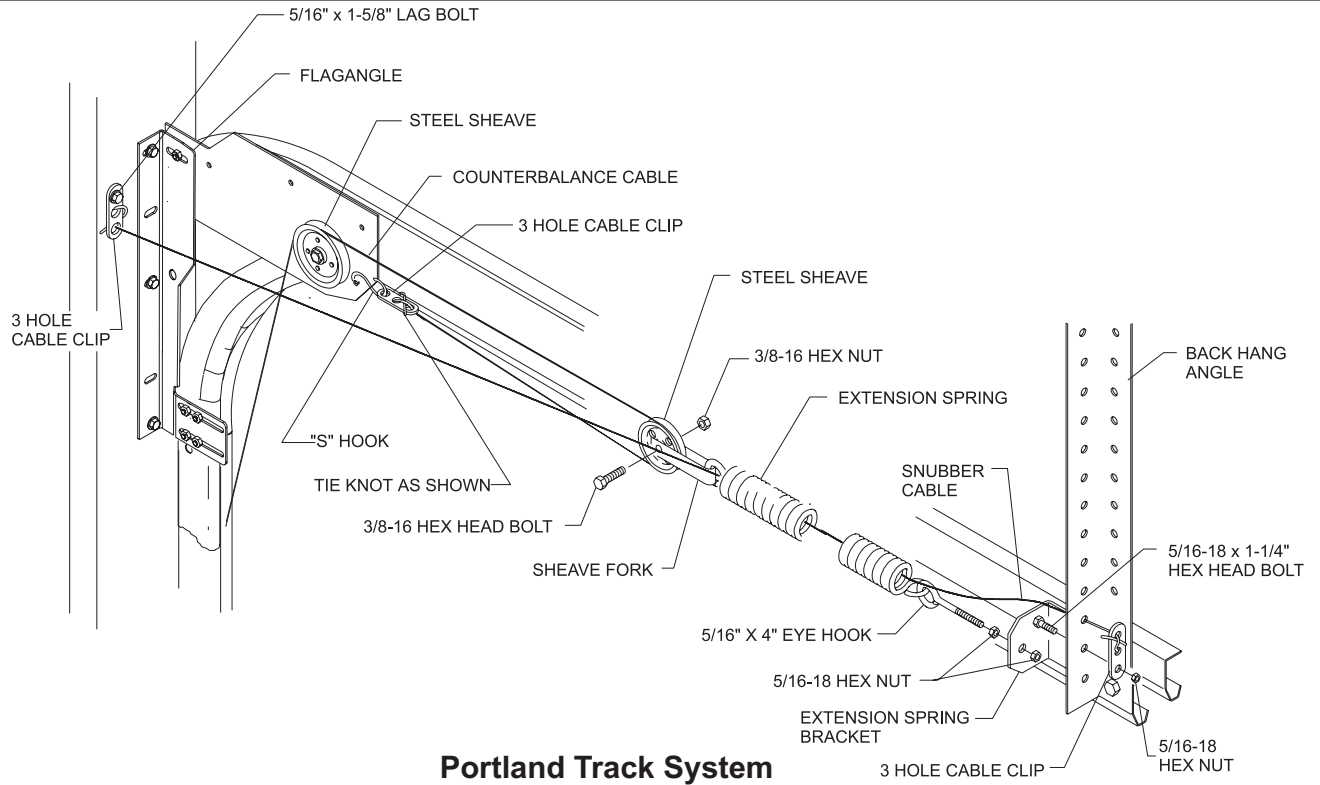

FIG. 12.3

Extension Spring Installation

Place a 5/16" hex nut over the end of each eyehook. Locate the 5/16" x 4" eyehooks through the holes in the extension spring brackets at the rear of the horizontal track. Secure the eyehooks with a second 5/16" hex nut as shown in Figures on next page. Secure the snubber cables to the hanger angle using (1) 3 hole clip and a 5/16-18 x 1-1/4" hex head bolt and nut on each side. Hook one end of each extension spring over the eyehooks. Feed the snubber cables through the extension springs and secure the loose ends to the jamb using a 3 hole clip and 5/16" x 1-5/8" lag bolt as shown. Place a sheave fork through the loose end of each spring and secure a steel sheave to it using (1) 3/8-16 hex head bolt and hex nut each. Feed the counterbalance cables over the steel sheaves as shown. Secure the cables to the track by tying a 3 hole clip to the end of the cables and hooking an "S" hook into the 3 hole clip and the sheave plate of the horizontal track, as shown in **FIG. 13.1**.

NOTE: See the provided installation manual for information on adjusting the cables.



Portland Track System

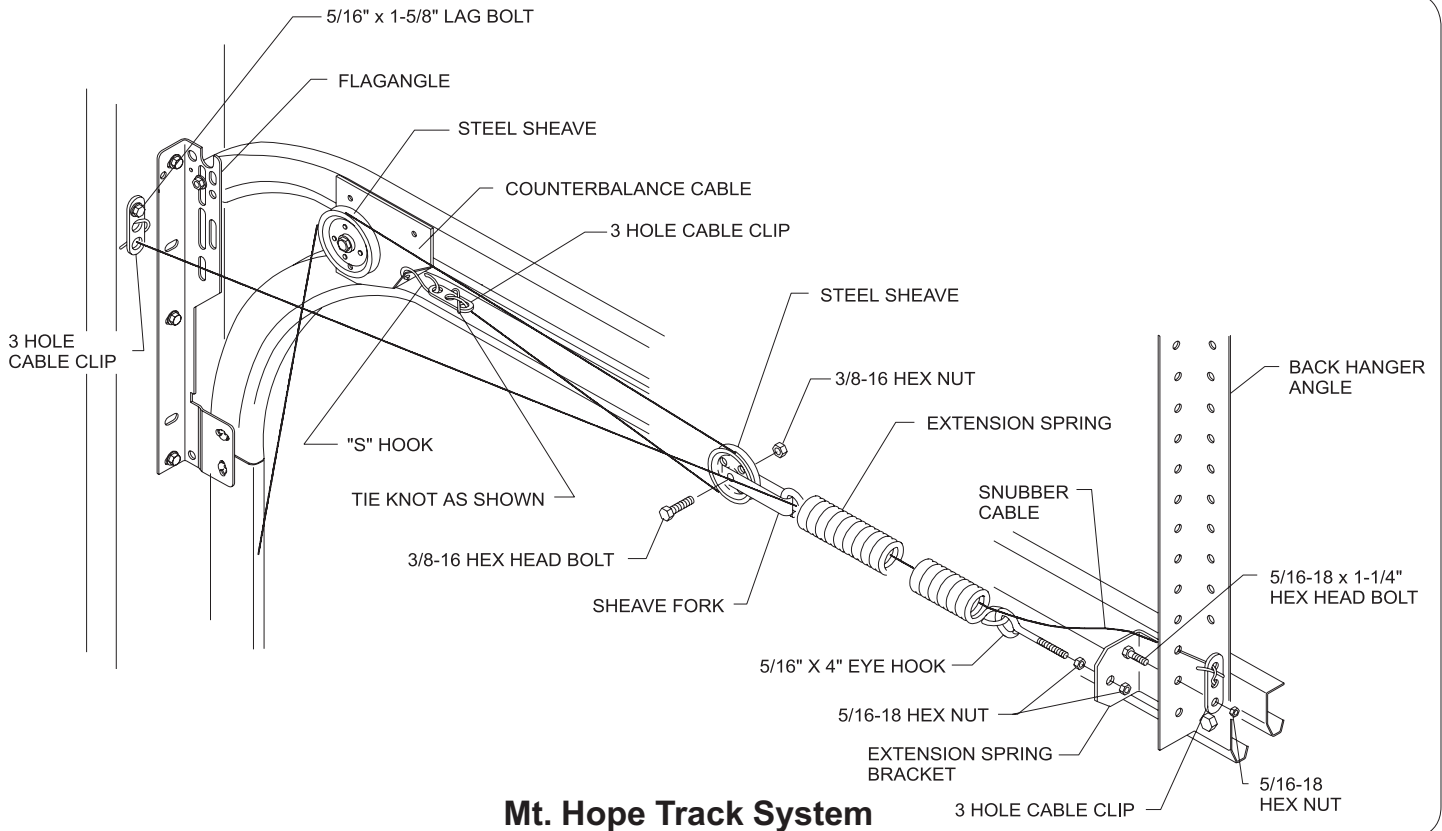

Mt. Hope Track System

FIG. 13.1