

HEADER ASSEMBLY REPLACEMENT INSTRUCTIONS FOR DOOR MODELS 888 AND 889



This installation manual provides the trained door technician information required to replace the belts.
READ COMPLETE INSTRUCTIONS BEFORE PROCEEDING WITH REPAIR.

Refer to the your Door Installation Instructions for additional safety warnings and precautions. Manual may also be used as a reference for any items that are not addressed by this document.
Installation Manuals can be accessed at <https://www.Wayne-Dalton.com/Documents>.

This manual is intended ONLY for professional use by a trained door systems technician.

- Follow the standard work below when replacing the header assembly. Failure to do so may result in severe or fatal injury.
- Refer to your Door Installation Instructions for additional safety warnings and precautions. Manual may also be used as a reference for any items that are not addressed by this document.

⚠ WARNING

These Doors are large, heavy objects that move. Since moving objects can cause injuries, your safety and the safety of others depends on you reading the information in this manual. If you have any questions or do NOT understand the information presented, call technical support at 1-800-764-1457 (Option 2).

In this section and those that follow, the words "**DANGER**", "**WARNING**", and "**CAUTION**" are used to stress important safety information. The word:

⚠ DANGER indicates an imminently hazardous situation which, if not avoided, is likely to result in death or serious injury.

⚠ WARNING indicates a potentially hazardous situation which, if not avoided, could result in death or serious injury.

⚠ CAUTION indicates a potentially hazardous situation which, if not avoided, may result in injury or property damage.

The word **NOTE** is used to indicate important steps to be followed or important considerations.

1. With the door in the fully closed position, remove the bolts that hold the guide covers in place. Set bolts aside in a safe place and open guides, as shown in **FIG 1.0**.

NOTE: Guide covers swing open on hinges, or can be lifted off hinge pins and removed to ease installation.



FIG 1.0

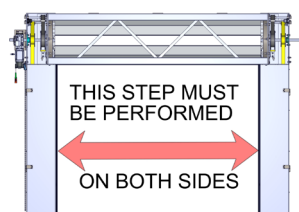

2. Place wood blocking under the counterweights and position the door in the full open position, as shown in **FIG 2.0**.

⚠ WARNING

LINE POWER should **DE-ENERGIZED** at this time. In the following steps electrical components will be physically removed and new components mounted. Ensure that all incoming power supplies have been de-energized prior to beginning work on attachment of electrical control systems. Use proper Lock Out/Tag Out procedures. Do NOT connect components to electrical supply until directed to do so. Failure to follow this warning could result in serious injury or death as well as equipment damage.

Remove the bolts that fasten the shipping bracket to the headplate. Flip the shipping bracket and reinstall the shipping bracket to the headplate, as shown in **FIG 2.1**. Loosen and remove the yellow counterbalance belt from the ratchet, as shown in **FIG 2.2**.

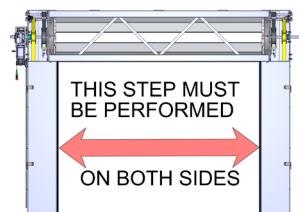
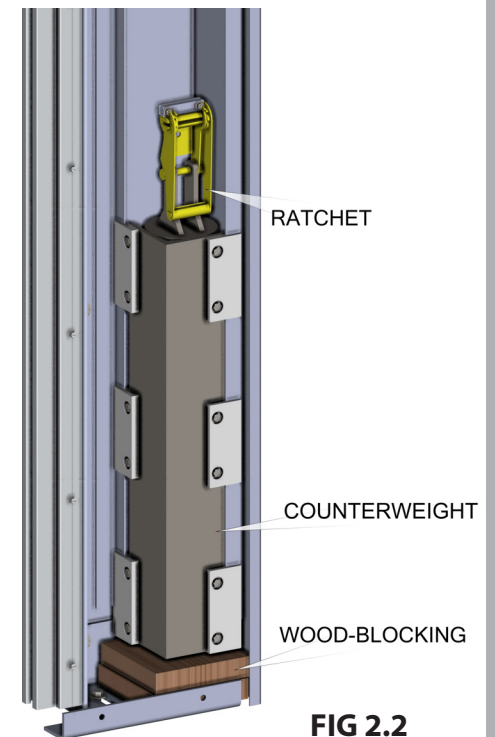
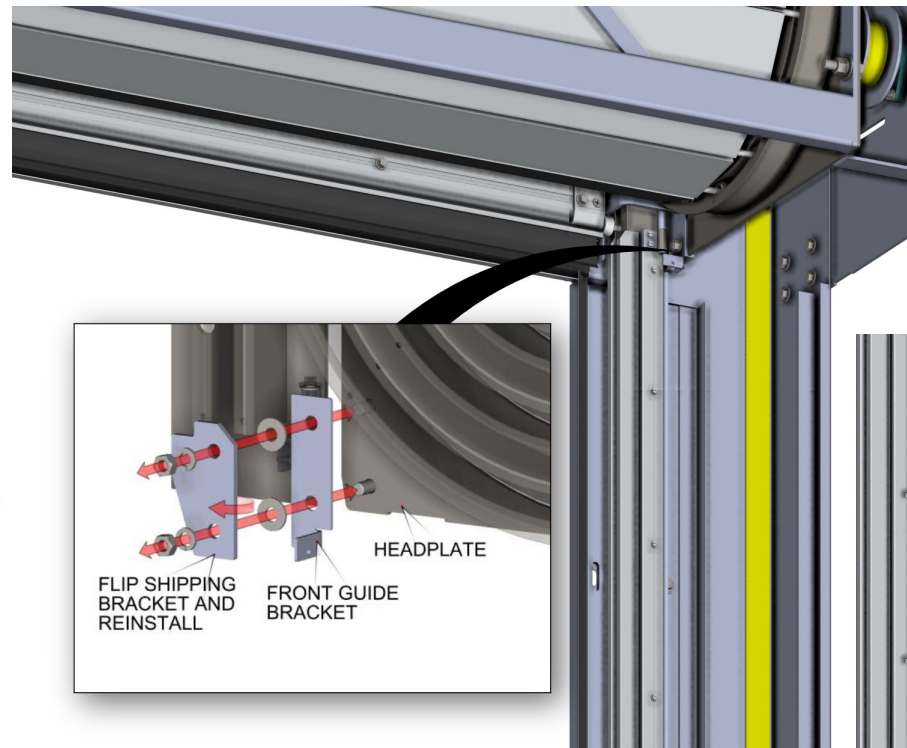
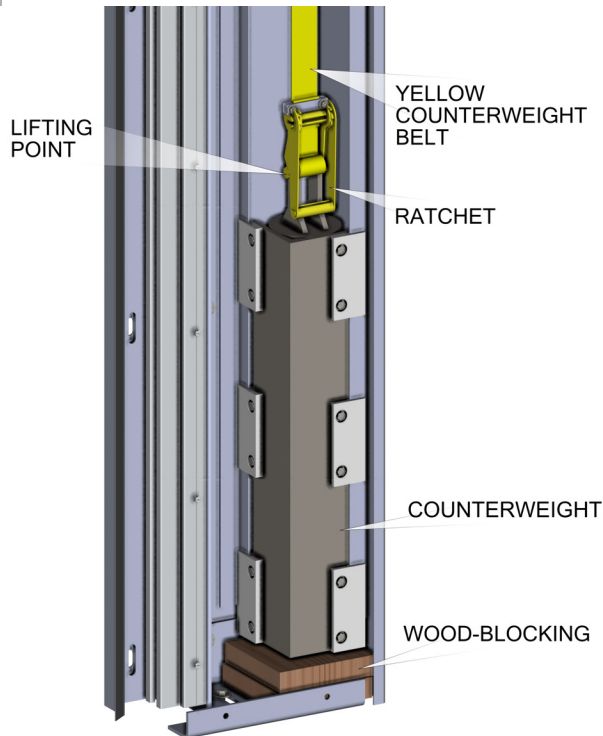

3. Loosen the set screw in the set collars. Remove the hex nuts from the idler assemblies. Remove the yellow counterbalance belt and set aside. Loosen and remove grey drive belt from ratchet. Remove the grey drive belt and set aside. Remove idler assemblies and set aside, as shown in FIG 3.0.

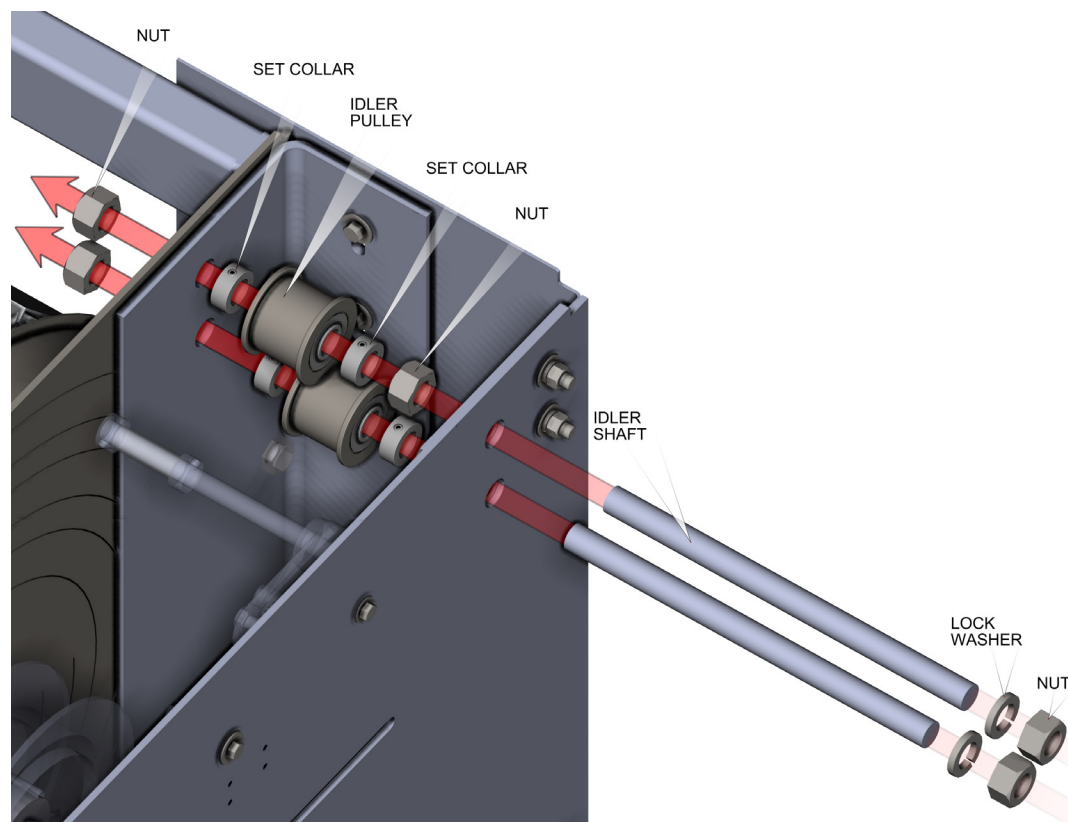
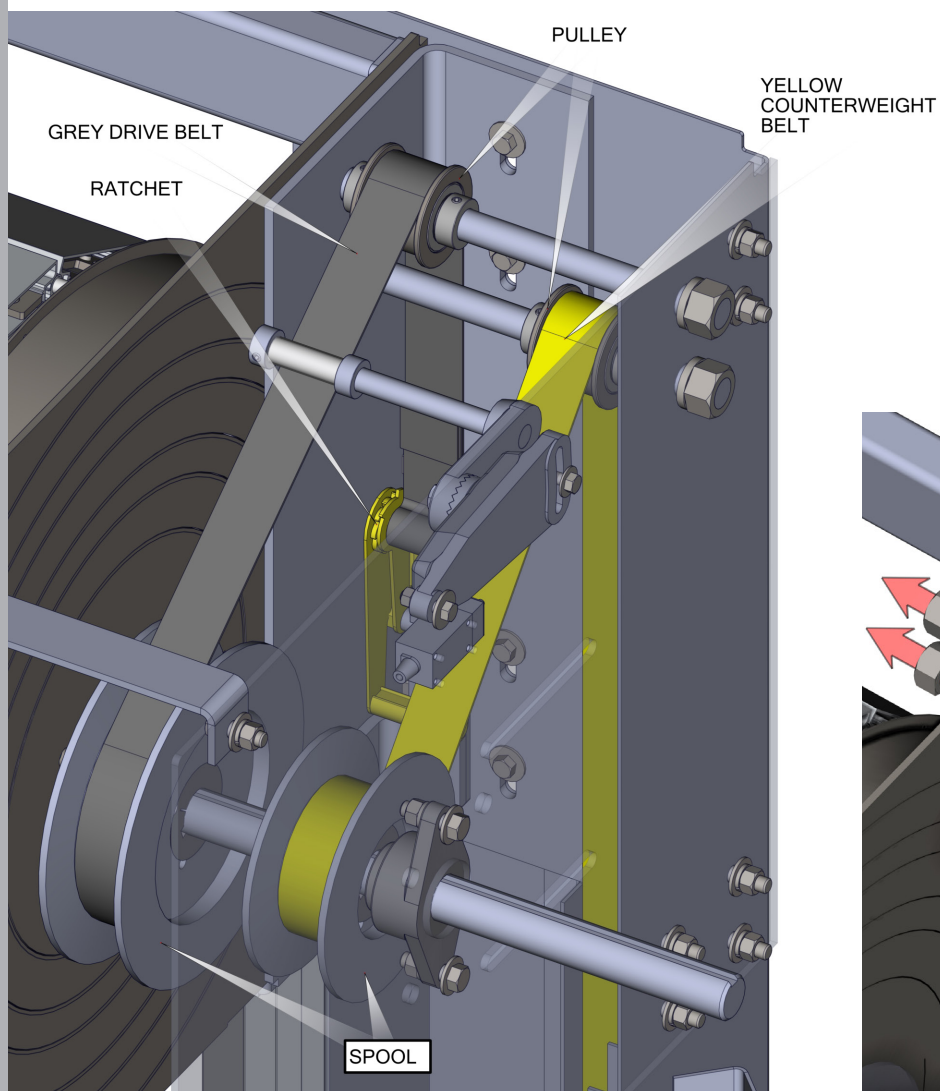

FIG 3.0

4. Remove the encoder bolts and take chain off sprockets. Next, remove the encoder and sprocket from the motor and set aside. Unbolt the motor and set aside. Slide the motor off from the shaft and set the key aside. Remove bolts from side plate. Remove plate and set the aside, as shown in **FIG 4.0**.

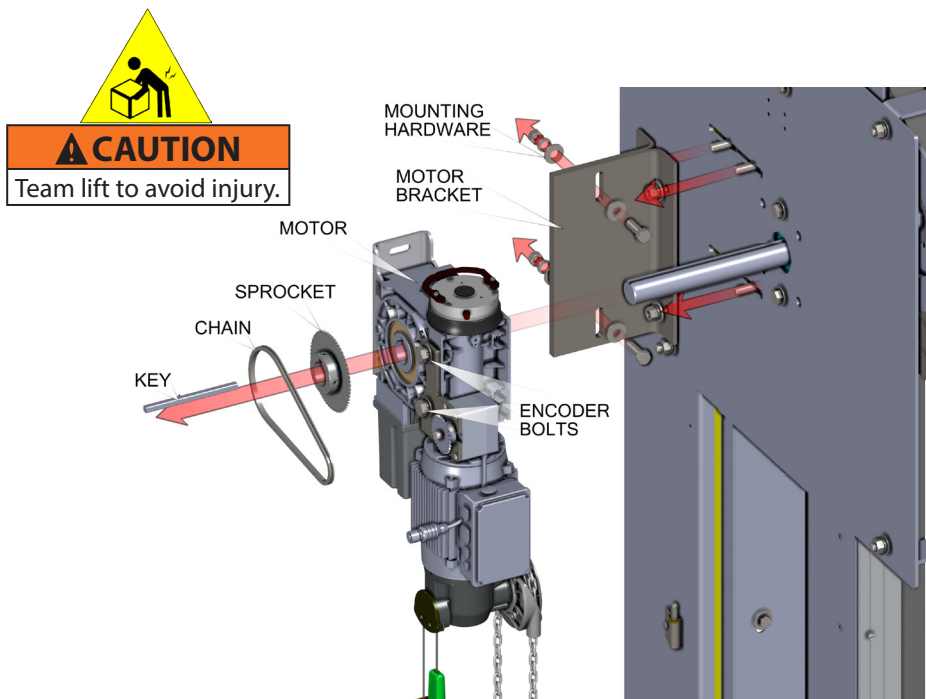
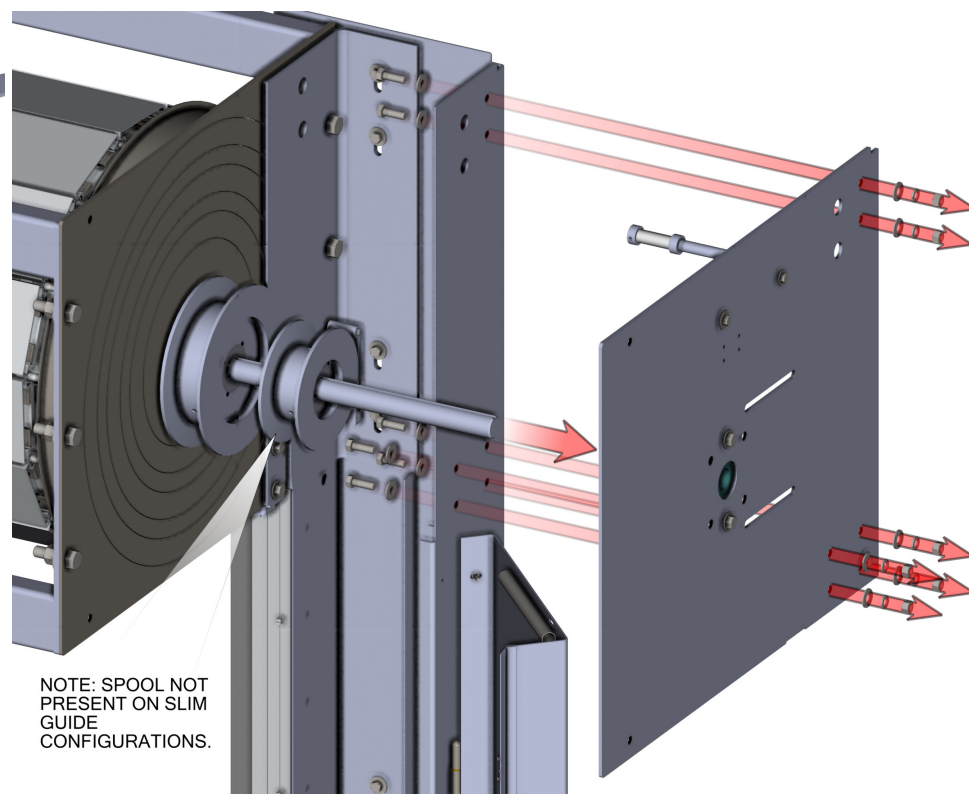

FIG 4.0



5. Place a lifting device under the header. Remove the top 4 wall anchors in the guides and set the aside. Next, remove alignment pin and set the aside. Remove the header assembly and set aside, as shown in **FIG 5.0**.

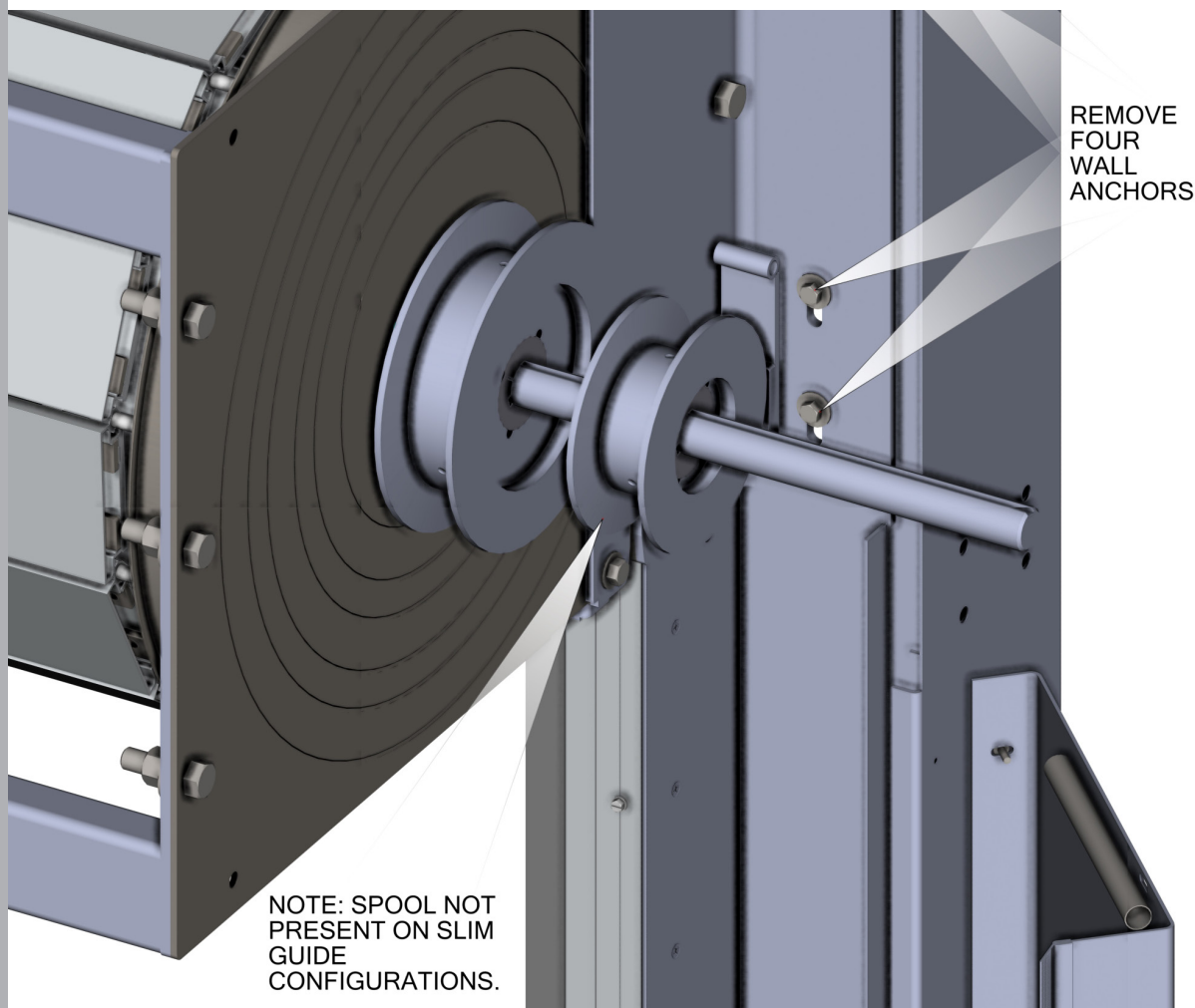
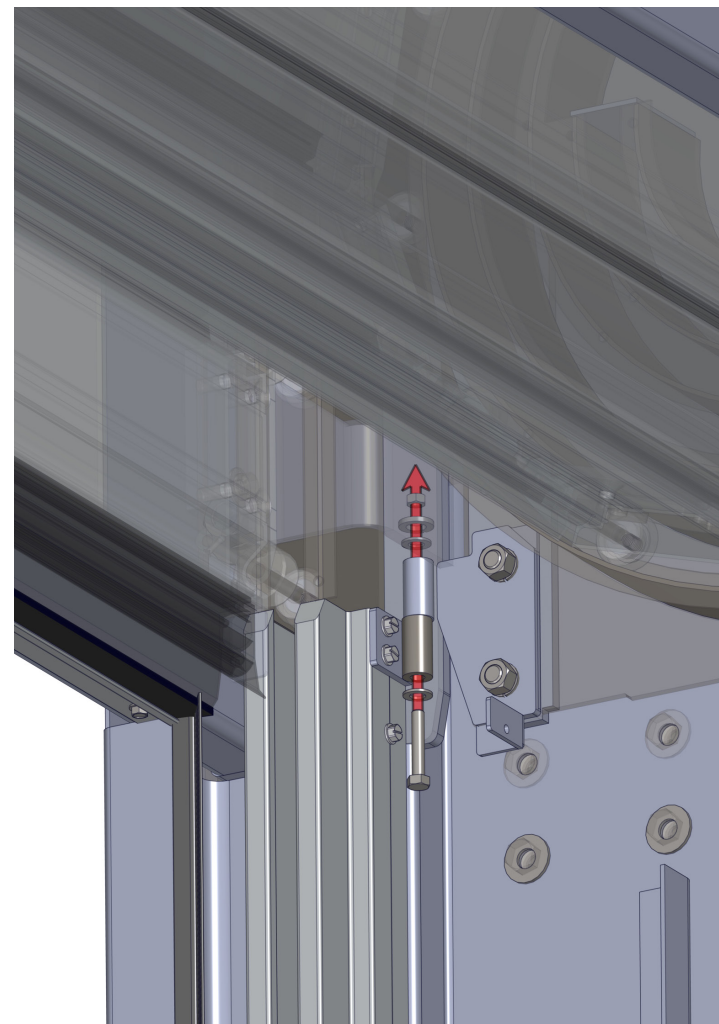

FIG 5.0



WARNING

Use appropriate lifting equipment to avoid serious injury or death.

6. Reinstall Header assembly according to factory install manual.

- Lift header and use alignment pin to set into place
- Install final four wall anchors
- Install side plates
- Install Idler assemblies
- Run belts to Counterweights and curtain bracket
- Install motor, encoder, sprocket and chain
- Install counterweights
- Remove, slip and install shipping bracket
- Level curtain by adjusting straps
- RE-ENERGIZED the power to the power supply.
- Cycle door a few times and verify it is in good working order.
- Close or re-attach the guide covers, as shown in **FIG 1.0**.