

# HIGH LIFT TRACKS

## Supplemental insert

©Copyright 2018

Part No. 288956

REV9 12/06/2018

This supplemental installation instruction is to be used as a supplement to the main Installation Instruction and Owner's Manual provided with the door. The instructions included in this document are ONLY those which deviate from the standard installation. All WARNINGS and CAUTIONS listed in the main manual are applicable to this supplemental instruction as well.

## INSTALLATION

1

Refer to your installation instruction manual for installing vertical track, sections and the section hardware in conjunction with this insert.

**NOTE:** To obtain the maximum amount of Hi-Lift applications, follow these general rules:

- If you have 400-54 Cable Drums = Headroom Minus 10"
- If you have 5250-54 500-84 or 5750-120 Cable Drums = Headroom Minus 12"
- If you have 800-120 or 6375-164 Cable Drums = Headroom Minus 14", as shown in FIG. 5.1.

2

### Installing Upper Track

**For One Piece Wall Angle:** For the one piece wall angle, the lower vertical track is factory installed to the wall angle, as shown in FIG. 2.1.

**For Two Piece Wall Angles:** Loosely fasten the upper vertical track to the track splice plate using (2) 1/4" - 20 x 9/16" track bolts and whiz nuts, as shown in FIG. 2.2.

**For One or Two Piece Wall Angles:** Attach the upper vertical track to the jamb using 5/16" x 1" self drilling screws for steel jambs and 5/16" x 1-5/8" lag screws for wood jambs at each hole location. After upper vertical track is properly attached to the door jamb, tighten all 1/4" - 20 x 9/16" track bolts and whiz nuts, as shown in FIG. 2.1 and FIG. 2.2.

3

### Installing Horizontal Track

Attach the horizontal track angle to the wall angle using (1) 3/8" truss head bolt and nut. Fasten the horizontal track to the track splice clip using (4) 1/4" - 20 x 9/16" track bolts and flange hex nuts.

**NOTE:** Reinforcing plates are provided with all 800-120 and 6375-164 cable drums.

**NOTE:** In dual shaft applications, the reinforcing plates are intended for the main shaft of the door.

**IMPORTANT:** FOR SIDE MOUNTED JACKSHAFT OPERATED DOORS, THE DRIVE SPROCKET SHOULD INSTALL ON THE MAIN SHAFT OF THE DOOR.

Attach reinforcing plate to horizontal track angle with (2) 3/8" - 16 x 1" bolts and nuts; secure to angle with (2) 5/16 x 1" self drilling screws, as shown in FIG. 3.1.

Refer to your installation instruction manual for installing rear back hangers to the end of horizontal track.

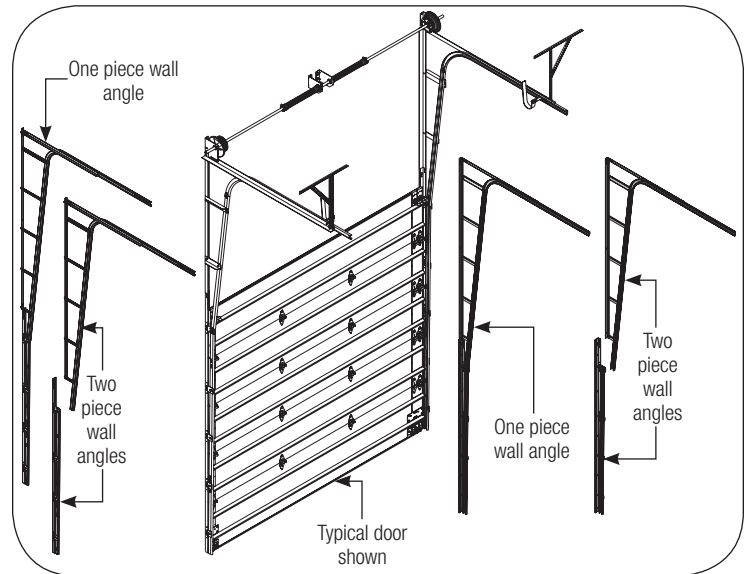

FIG. 1.1

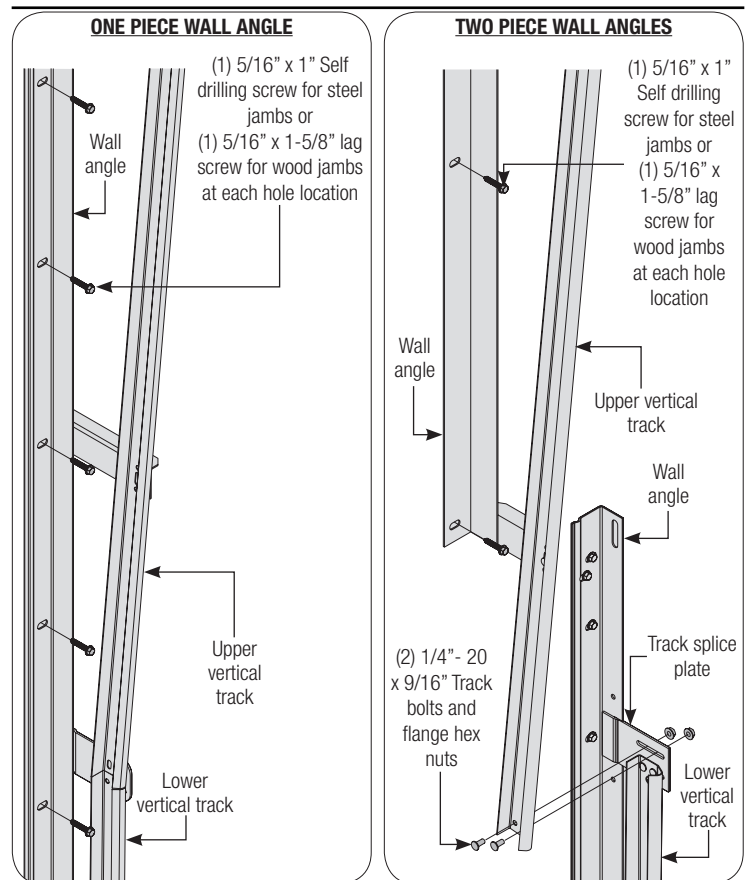

FIG. 2.1

FIG. 2.2

4

## Installing Torsion Springs

Ensure proper cable drums were provided with the door, high lift cable drums are flat at one end and tapered at the other. Lift torsion spring assembly into place.

Secure the end bearing brackets to the horizontal track angle using 3/8" truss head bolts and nuts. Next, attach the end bearing brackets to the door jamb using (3) 5/16" x 1-5/8" lag screws for wood jambs or (3) 5/16" x 1" Self drilling screws for steel jambs, as shown in **FIG. 5.1**. Attach the counterbalance cable to the cable drum, as shown in **FIG. 4.1**.

### **WARNING**

**IT IS STRONGLY RECOMMENDED THAT SAFETY COMPONENT OPTIONS, SUCH AS CABLE FAILURE DEVICES BE USED WITH EVERY HIGH LIFT TRACK INSTALLATION. IF DOOR IS, OR LATER BECOMES MOTOR OPERATED, SENSING EDGES AND ELECTRICAL INTERLOCKS WITH DOCK LEVELERS AND OPERATIONAL DOOR LOCKS SHOULD BE INSTALLED. WITHOUT SUCH SAFETY EQUIPMENT, A DOOR THAT BECOMES INOPERATIVE IN THE OPEN POSITION COULD FREE-FALL, CAUSING SEVERE INJURY OR DEATH.**

5

## Attach Bumper Springs

Refer to the installation instruction manual for installing the rear back hang supports prior to installing the bumper springs. Attach the bumper spring to the "L" shaped bumper spring bracket using (2) 3/8" x 1" bolts. Raise the door to 2" - 4" past the fully open position. Align bumper spring with the return flange of the top fixture. Attach the bumper spring assembly to the horizontal track using supplied fasteners, shown in **FIG. 6.1**. **DO NOT WELD.**

**IMPORTANT: REAR BACK HANGS MUST BE INSTALLED BEFORE ATTEMPTING TO RAISE THE DOOR.**

### **WARNING**

**REAR BACK HANGS MUST BE INSTALLED BEFORE ATTEMPTING TO RAISE THE DOOR. FAILURE TO DO SO CAN RESULT IN DOOR FALLING AND CAUSING SEVERE INJURY OR DEATH.**

### **WARNING**

**ATTACHING BUMPER SPRINGS BY WELDING CAN CAUSE SPRINGS TO BREAK WHEN IMPACTED BY DOOR, RESULTING IN SERIOUS INJURY OR DEATH FROM FALLING PIECES.**

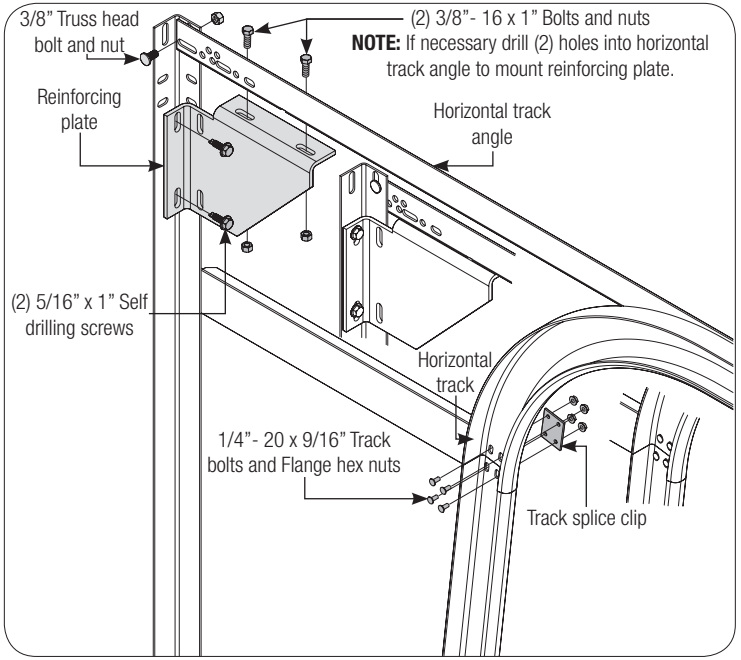

FIG. 3.1

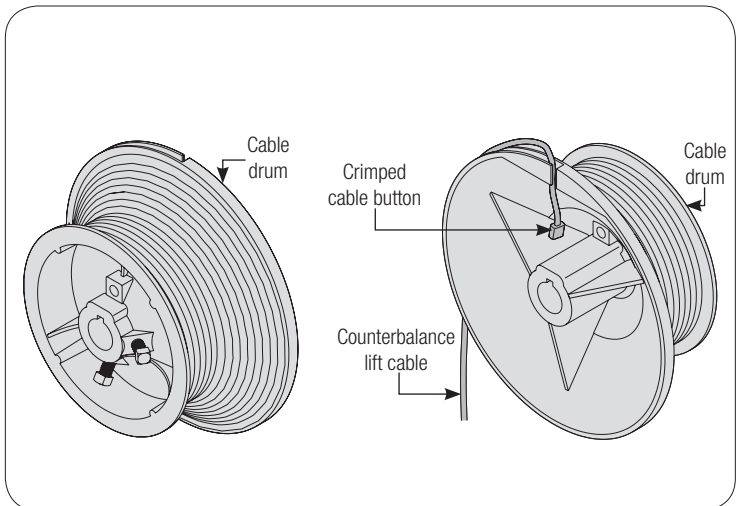

FIG. 4.1

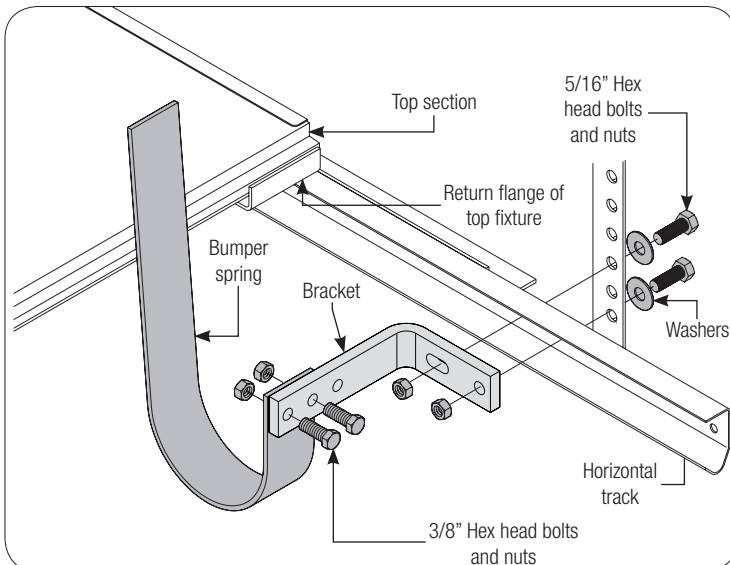

FIG. 6.1

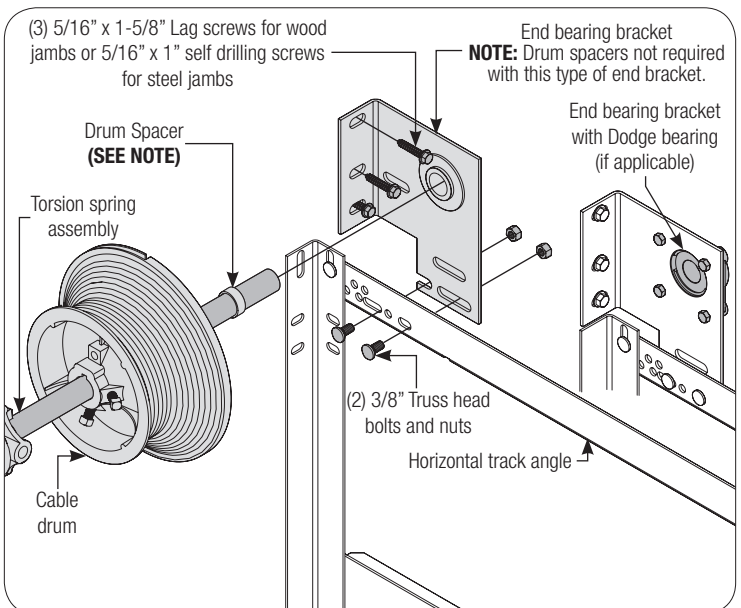

FIG. 5.1