

Installing Fully Adjustable Jamb Brackets

Supplemental insert

©Copyright 2016 Wayne Dalton, a division of Overhead Door Corporation

Part No. 345128

REV1 05/03/2016

This supplemental installation instruction is to be used as a supplement to the main Installation Instruction and Owner's Manual provided with the door. The instructions included in this document are ONLY those which deviate from the standard installation. All WARNINGS and CAUTIONS listed in the main manual are applicable to this supplemental instruction as well.

www.Wayne-Dalton.com

INSTALLATION

Tools Needed: Tape Measure, Hacksaw, Power Drill, 5/16" Drill Bit

1

Installing fully adjustable jamb brackets

Vertical track must be cut to the proper length prior to installation.

IMPORTANT: DOORS THAT ARE 7'-0" OR 8'-0" IN HEIGHT DO NOT REQUIRE CUTTING THE VERTICAL TRACK.

Determine the radius of your horizontal track, as shown in **FIG. 1.1**. Using this measurement, refer to the vertical track cutting chart to determine the length of the vertical track. Cut the track off at the TOP, as shown in **FIG. 1.2**.

Now, two holes must be drilled into the top of the cut vertical track. Refer to the illustration shown in **FIG. 1.3**, for hole locations. Use a 5/16" drill bit.

Repeat for other vertical track.

To attach the bottom jamb bracket, JB-1, locate the first set of quick install features of the vertical track. Align the slot in the jamb bracket with the slot above the quick install features in the vertical track. The long side of the bracket is placed against the track. Fasten the jamb bracket finger tight, using (1) 1/4" - 20 x 5/8" carriage bolt and (1) 1/4" - 20 flange hex nut, as shown in **FIG. 1.2** and **FIG. 1.4**.

To attach the top jamb bracket, JB-1, locate the third set of quick install features of the vertical track. Align the slot in the jamb bracket with the slot above the quick install features in the vertical track. The long side of the bracket is placed against the track. Fasten the jamb bracket finger tight, using (1) 1/4" - 20 x 5/8" carriage bolt and (1) 1/4" - 20 flange hex nut, as shown in **FIG. 1.2** and **FIG. 1.4**.

Repeat for other vertical track.

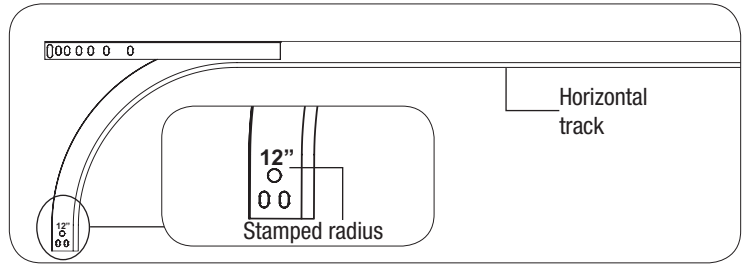

FIG. 1.1

Vertical Track Cutting Chart	
Horizontal Track Radius	Vertical Track Cut Length
10", 12"	Door Height Minus 10"
14"	Door Height Minus 8"
3-1/2" LHR	Door Height Minus 15"
6-1/2" LHR	Door Height Minus 12"

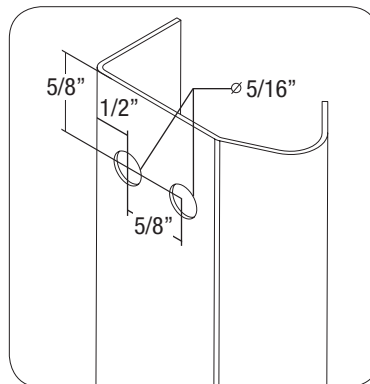

FIG. 1.3

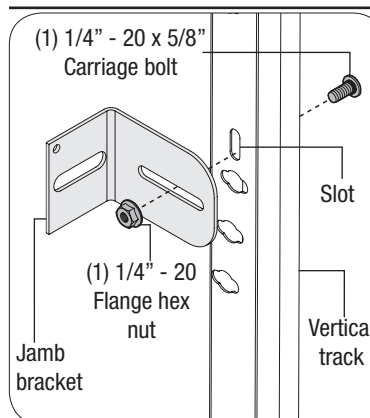

FIG. 1.4

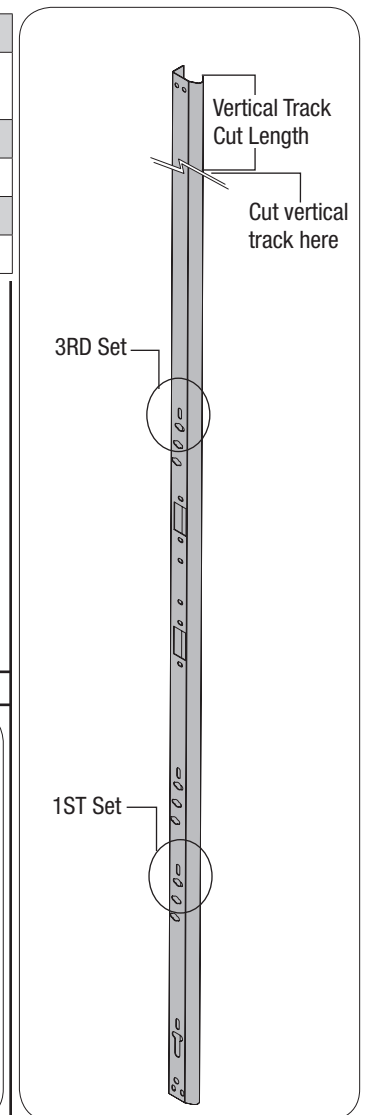

FIG. 1.2