

Installation Instructions

This installation instruction is to be used as a supplement to the main Installation Instruction and Owner's Manual provided with the door. The instructions included in this document are only those which deviate from the standard installation. All warnings and cautions listed in the main manual are applicable to these instructions as well.

INSTALLATION

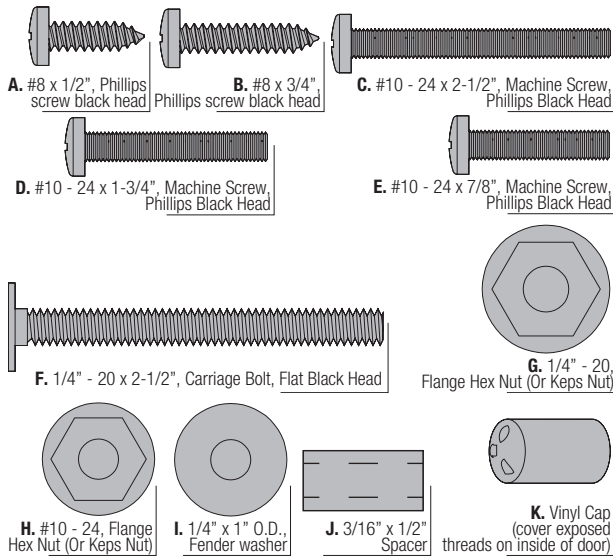

FOR FENDER WASHERS: (For use with vinyl-back insulated and paper-back insulated doors.)

FOR VINYL CAPS: (Cover exposed threads on inside of door.)

- .156" Dia. for #10 screws / - .188" Dia. for 1/4" screws and bolts

Fastener Application Table:

#8 Sheet metal screws (A / B) 1/8" Pre-drilled holes	#10 - 24 Screws (C / D / E) 3/16" Pre-drilled holes	1/4" - 20 Screws (F) 3/16" Pre-drilled holes
Hinge strap, Corner bracket, Angle bracket	Pull handle, Cast lift handle, Cast knocker	Lift handle, Stamp knocker

WARNING

TO AVOID POSSIBLE INJURY, LIFT HANDLES THAT ARE INSTALLED WITHIN 4 INCHES (102 MM) OF A SECTION INTERFACE SHALL PROMOTE VERTICAL ORIENTATION OF THE HAND.

NOTE: Depending on your door's thickness, you may need to cut off the protruding ends of the bolts after securing the pull handle(s) to the section. If the bolts are cut off, use a file to smooth rough edges.

CAUTION

FAILURE TO SMOOTH BOLT ENDS OR INSTALL VINYL CAPS MAY RESULT IN POSSIBLE INJURY.

Door must be completely installed and cycled a minimum of 3 times, prior to attaching hinge straps to the section rails, since the door is likely to shift left or right when first cycled.

NOTE: Door must be fully operational and functional with perimeter seal installed.

IMPORTANT: WHEN POSITIONING HINGE STRAP, IT MUST NOT CONTACT THE PERIMETER SEAL AS DOOR OPENS AND CLOSES. KEEP THE EDGE OF THE HINGE STRAP A MINIMUM OF 1/4" AWAY FROM THE PERIMETER SEAL.

PYRAMID, ROUND CLAVOS AND DOOR STUDS:

IMPORTANT! USE THE STRUCTURAL POLYURETHANE ADHESIVE (NOT SUPPLIED), TO PERMANENTLY ATTACH THE PYRAMID, ROUND CLAVOS OR DOOR STUDS. TAKE NOTE OF THE ADHESIVE INSTRUCTIONS FROM THE MANUFACTURER.

For 9100 doors, drill 11/32" holes at mounting locations, insert spacer **J**, into hole.

For 9400 doors, pre-drill 1/8" holes. Then, using 11/32" bit from the panel backside drill through backer and slowly through foam thickness. When the bit reaches steel panel, stop immediately. Insert spacer **J**, into 11/32" hole. Continue with hardware assembly.

THE #10 X 1" FENDER WASHERS ARE ONLY REQUIRED IF: The screws protrude through the insulation panel, the nuts are mounted to the insulation vinyl backer or the screws are not secured to an end or center stile.

HINGE STRAPS AND CORNER BRACKETS:

NOTE: For door steel panels only, pre-drill 1/8" holes (quantity as required). Pre-drilling into wood trim is not required.

SCREW TIGHTENING: For insulated doors with tough-guard or vinyl backers, finger-tighten nut until nut makes contact with washer, then tighten 1-1/2 to 3 turns only. For steel backers, 1 to 2 turns.

WARNING

DO NOT OVER TIGHTEN NUT WHEN HARDWARE IS INSTALLED ON FOAM INSULATED DOORS. OVER-TIGHTENING WILL PULL NUT AND WASHER THROUGH THE BACKER SURFACE.

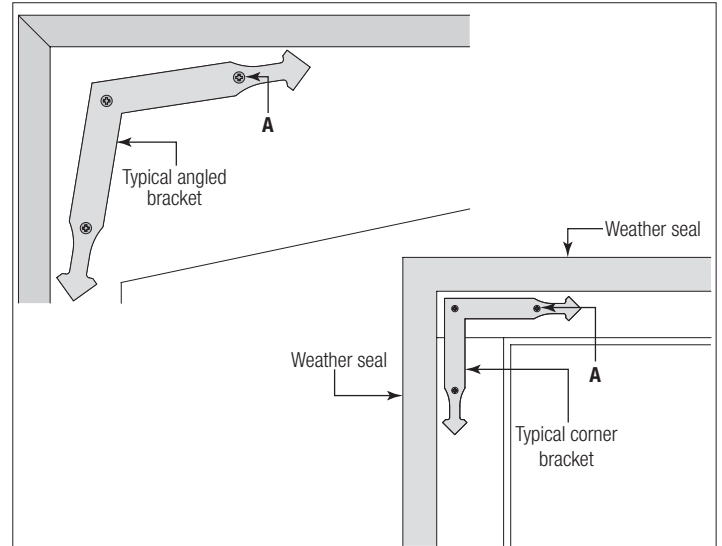
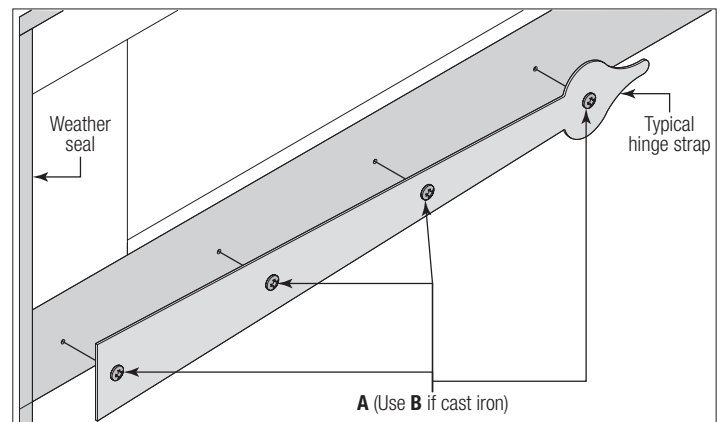

IMPORTANT: MOUNTING AN EXTERIOR HANDLE TOO CLOSE TO THE HEADER MAY RESULT IN THE HANDLE IMPACTING THE HEADER AS THE DOOR OPENS. CONFIRM CLEARANCE PRIOR TO ATTACHING HANDLE. TO VERIFY CLEARANCE, TEMPORARILY TAPE THE EXTERIOR HANDLE TO THE SECTION IN THE DESIRED LOCATION. USING INTERIOR HANDLES OR GRIPPING POINTS, SLOWLY LIFT THE DOOR AND CONFIRM THAT THE EXTERIOR HANDLE CLEARS THE HEADER. VERIFY AT LEAST 1/2" CLEARANCE TO ALLOW FOR POSSIBLE FUTURE BOWING OF SECTIONS, E.G. DUE TO TEMPERATURE VARIATIONS.

NOTE: Flagangle removed for clarity.

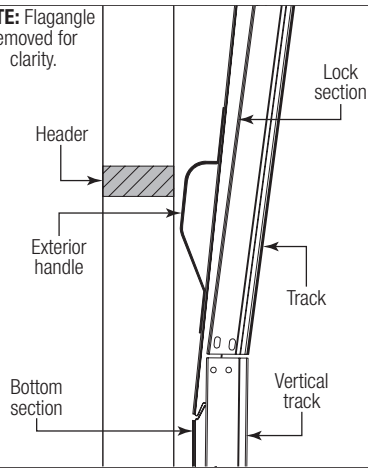

NOTE: Mount pull handle to the second section for maximum clearance. Mounting to the third section may be possible, but verify clearance before permanent attachment. There is reduced clearance of the section and exterior handle for track options such as 32" Radius, High Lift or Vertical Lift. With careful placement of the handle and adjustments to seals, it is possible to install these with clearance to the header.

