

This supplemental installation instruction is to be used in conjunction to the main Installation Instruction and Owner's Manual provided with the door. The instructions included in this document are only those which deviate from the standard installation. All warnings and cautions listed in the main manual are applicable to this supplemental instruction as well.

P.O. Box 67 Mt. Hope, OH., 44660 www.Wayne-Dalton.com

FOR 9100, 9405, 9600 WINDLOAD APPLICATIONS:

1. Replace **Step 11 "Strut (U-shaped)"** of the Main Installation Instruction with **Step "Strut (U-shaped)"** of this supplement.
2. Replace **Step 12 "Strut (A-symmetrical)"** of the Main Installation Instruction with **Step "Strut (U-shaped)"** of this supplement.

STRUT (U-SHAPED)

NOTE: If a strut (U-shaped) is supplied, complete this step.

NOTE: All Bottom and Intermediate(s) Sections require strutting. The struts are typically installed on the top rib of the bottom and intermediate(s) sections.

Position and center the strut (U-shaped) over the top rib of the intermediate section, as shown.

1. Secure each end of the strut to the section surface using (2) 1/4" - 14 x 5/8" self tapping screws.
2. Secure the center of the strut to the top rib of the section using (2) 1/4" - 14 x 5/8" self tapping screws at each center hinge location(s).
3. Secure the rest of the strut to the top rib of the section using (2) 1/4" - 14 x 5/8" self tapping screws in between the center hinges and the ends of the strut.

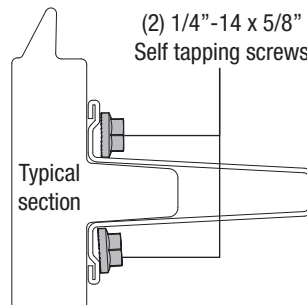
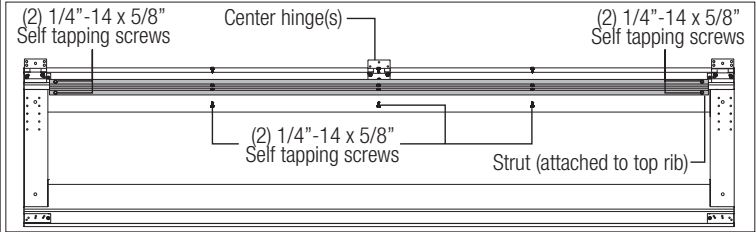

ATTACHING ENDS OF STRUT

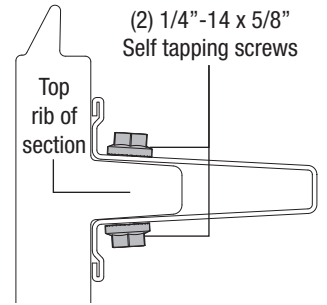

ATTACHING CENTER OF STRUT