

Installation Instructions

These installation instructions are to be used as a supplement to the main Installation Instructions and Owner's Manual provided with the door. The instructions included in this document are ONLY those which deviate from the standard installation. All WARNINGS and CAUTIONS listed in the main manual are applicable to these instructions as well.

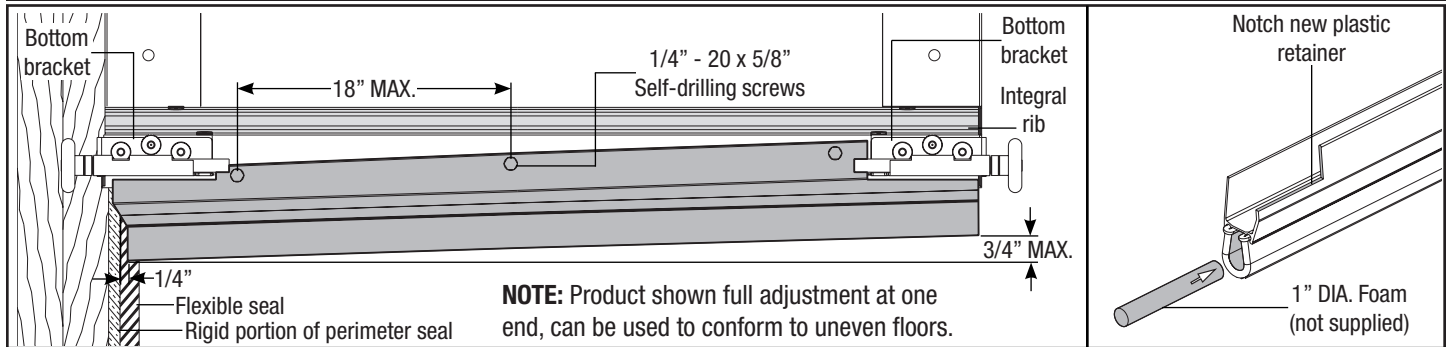

Fig. 1

Fig. 2

STEP 1: Raise the door to a desired height, making sure the astragal is accessible. Place two locking pliers on the horizontal track, one in front of the top bracket roller and one behind the top bracket roller.

⚠ WARNING FAILURE TO CLAMP TRACK CAN ALLOW DOOR TO FALL, POSSIBLY CAUSING SEVERE INJURY.
On one side, pry the corner of the astragal retainer open using a flat head screwdriver. Pull down firmly on astragal, removing it completely from the astragal retainer. Remove all lower #8 screws in astragal retainer and move them to the upper pre punched holes, as shown in **Fig. 3**.

STEP 2: Cut the new plastic retainer to section width minus 1/2". Notch the adjustable astragal retainer to fit around the bottom brackets, as shown in **Fig. 1 and Fig. 2**.

STEP 3: Install new plastic retainer onto existing astragal retainer, positioning it so that the high point of the plastic retainer is tight against the lower integral rib. The plastic retainer can then be adjusted to a maximum of 3/4". Secure plastic retainer to the section using 1/4" - 20 x 5/8" self-drilling screws, up to 18" apart, as shown in **Fig. 1**. Install screws into flat portion of steel retainer, as shown in **Fig. 6**.

STEP 4: If you have the plastic retainer adjusted to the 3/4" maximum at one end of the section, it may be necessary to trim the end of the retainer at an angle to clear perimeter seal. Trim plastic retainer so there is 1/4" of clearance, as shown in **Fig. 4**. You will also need to install (1) #8 x 1/2" self-tapping screw in the outside edge of the plastic retainer into endcap, as shown in **Fig. 5**.

STEP 5: Re-install astragal into new plastic retainer. Fold ends back into ends to secure in place. If retainer is adjusted to the 3/4" maximum it may be necessary to install a 1" dia. foam (not supplied) into fully adjusted end, as shown in **Fig. 2**.

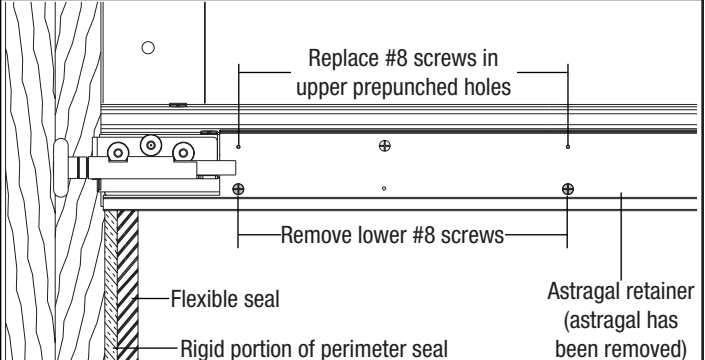

Fig. 3

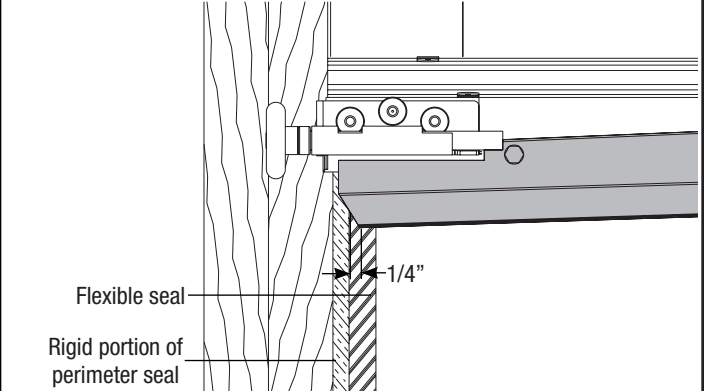

Fig. 4

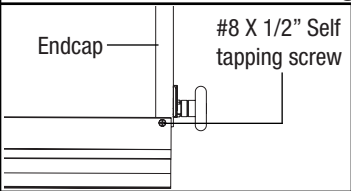

Fig. 5

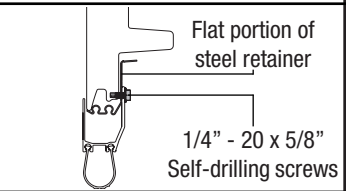

Fig. 6