

# Rim Cylinder / Night Latch Secure Lock



## Installation Instructions and Owner's Manual

All Residential Door Models: 5000, 9700, 9800, 8000, 9000 Series & Wood Doors

www.Wayne-Dalton.com

### PARTS BREAKDOWN

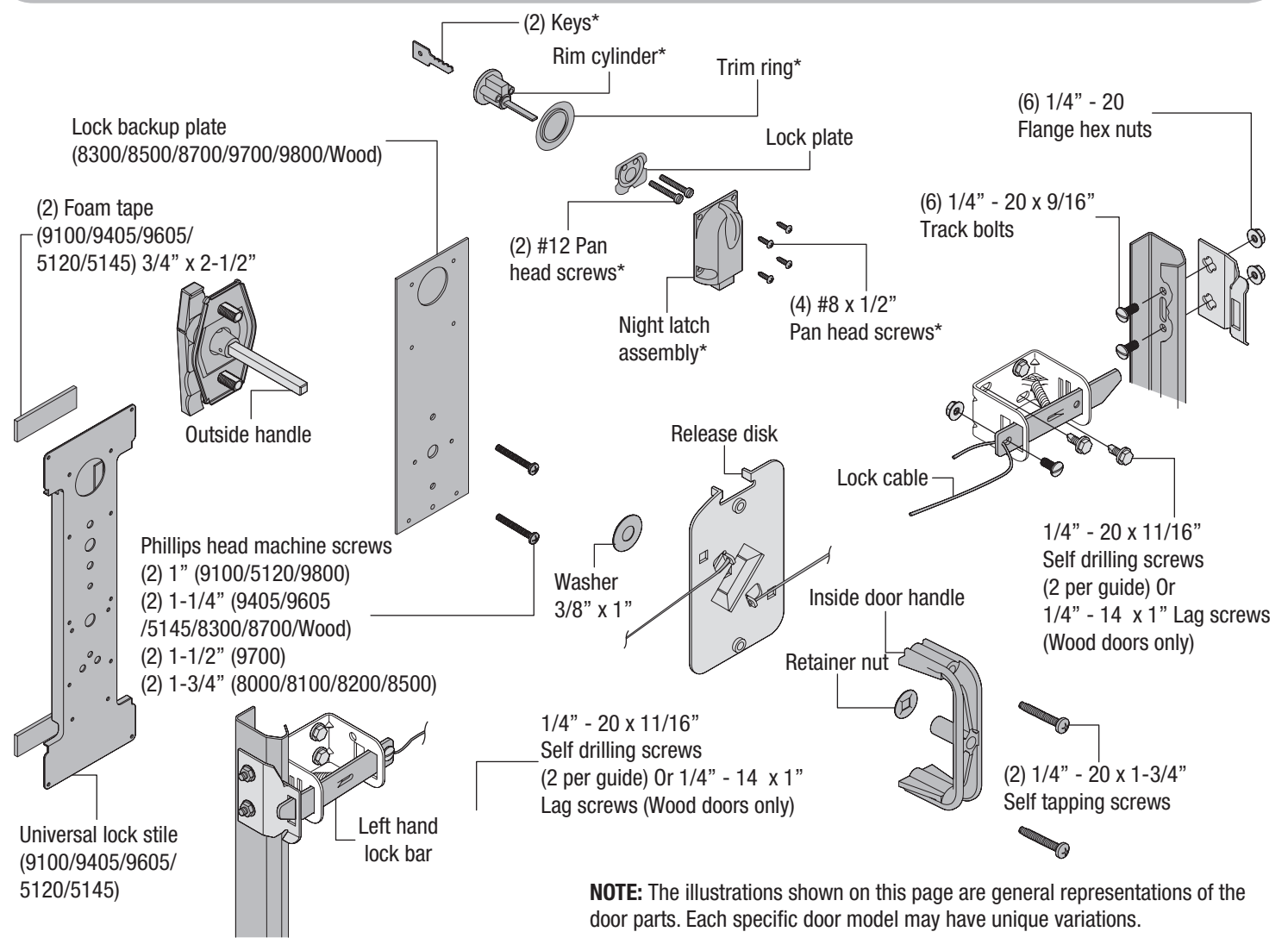

**NOTE:** The illustrations shown on this page are general representations of the door parts. Each specific door model may have unique variations.

**TOOLS REQUIRED:**

- (1) Electric Drill
- (1) 1/8" Drill Bit
- (1) 3/4" Dia. Hole Saw
- (1) 7/16" 6 Point Nut Driver
- (1) 7/16" Wrench Or Socket
- (1) Pliers/Wire Cutter
- (1) Phillips Screw Driver
- (1) Standard Screw Driver
- (1) Center Punch

**IMPORTANT NOTICE!** REFER TO THE DOOR MODEL INSTALLATION INSTRUCTIONS MANUAL FOR IMPORTANT SAFETY NOTICES.

# INSTALLATION

1

## Drilling Lock Section

### CAUTION

DO NOT DRILL LOCK SECTION OR INSTALL LOCK ON DOORS WITH OPENERS. THE DOOR AND/ OR OPENER MAY BE DAMAGED IF THE OPENER IS USED WHILE THE DOOR IS LOCKED.

**NOTE:** Common practice for doors with the odd number of raised panels is to mount the lock towards the right side of the section when looking out.

**IMPORTANT:** REMOVE ALL BURRS FROM THE DRILLED HOLES BEFORE INSTALLING THE LOCK TO THE SECTION.

**8000 / 8100 / 8200 DOORS:** Place the lock section face down on (2) padded sawhorses for a single car door or (3) padded sawhorses for a double car door. Locate the (4) hole pattern in the center stile of the lock section. Use the (4) holes as a template to drill (4) 1/8" holes through the section. Flip the section over, face up. With the section face up, enlarge the (3) bottom holes to 3/4" diameter and the top hole to 1-1/4" diameter, pay close attention not to drill completely through section into center stile.

**NOTE:** Do not drill through or enlarge holes in the center stile.

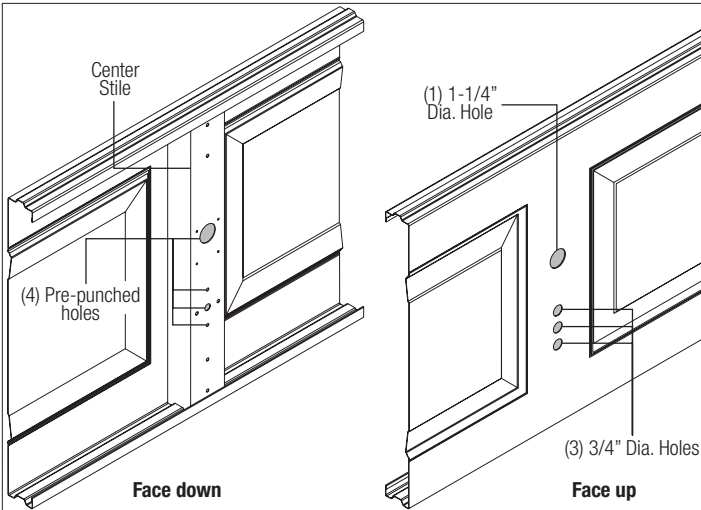

**9800 / 9700 / 8300 / 8500 / 8700 & WOOD DOORS:** Place the lock section face up on (2) padded sawhorses for a single car door or (3) padded sawhorses for a double car door. Locate the middle of the center stile, measure the distance from the end of the section to the middle of the center stile. Turn the section face down, transfer the measurement and mark a light vertical line, then mark a horizontal line at half the section height. Align the 7/16" diameter hole of the lock backup plate at the intersection point of the horizontal and vertical marks, use the lock backup plate as a template to mark the (4) holes, remove the lock backup plate and drill the (3) bottom holes to 3/4" diameter and the top hole to 1-1/4" diameter, drilling all (4) holes completely through the section.

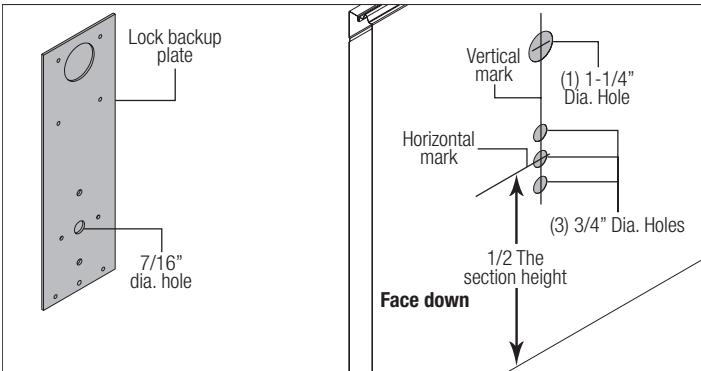

**5120 / 5145 / 9100 / 9405 & 9605 DOORS:** Place the lock section face up on (2) padded sawhorses for a single car door or (3) padded sawhorses for a double car door. Locate the middle of the center stile, measure the distance from the end of the section to the middle of the center stile. Turn the section face down, transfer the measurement and mark a light vertical line. Align the center of the lock stile with vertical mark, use the lock stile as a template to mark the (4) holes, remove the lock stile and drill the (3) bottom holes to 3/4" diameter and the top hole to 1-1/4" diameter, drilling all (4) holes completely through the section.

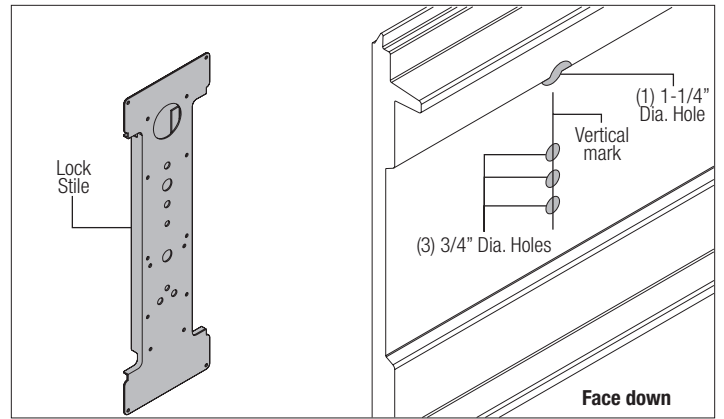

2

## Outside Lock Handle Assembly

**8000 / 8100 / 8200 DOORS:** Align the outside handle assembly with the handle pointing towards the floor and insert the assembly through the previously drilled 3/4" diameter holes in the section. Secure the outside lock handle to the section with (2) #10 phillips head screws.

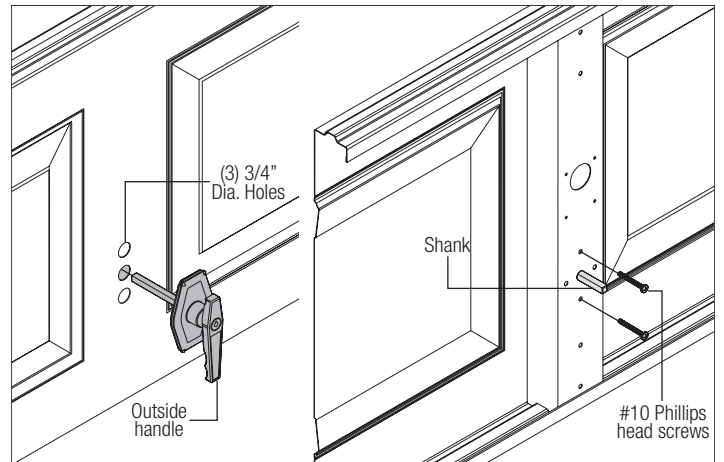

**9800 / 9700 / 8300 / 8500 / 8700 / 5120 / 5145 / 9100 / 9405 / 9605 & WOOD DOORS:** Align the outside handle assembly with the handle pointing towards the floor and insert the assembly through the previously drilled 3/4" diameter holes in the section. With the outside lock placed in the section, place the center lock stile over the shank of the outside lock handle, secure the center lock stile with foam tape (8300 / 8500 / 8700 / 9800 / 9700 & Wood doors will use the lock backup plate with no foam tape). Secure the outside lock handle to the section by placing the (2) #10 phillips head machine screws through the lock stile into the lock section.

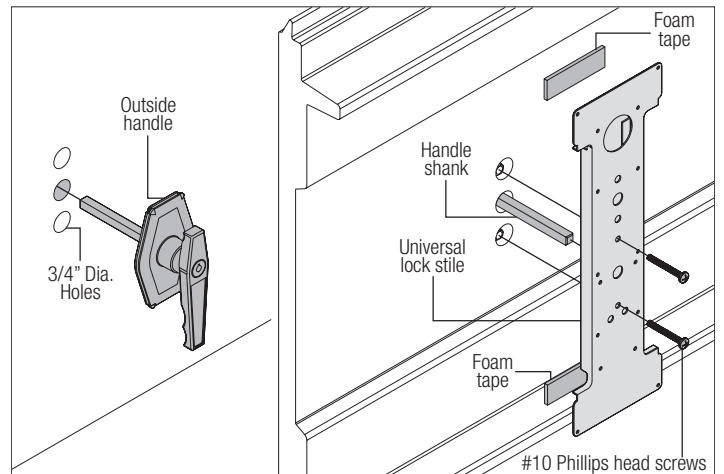

# 4 Installing The Secure Lock

Locate the secure lock striker plates over the pre-punched holes in the vertical track nearest the center of the lock section. Fasten the striker plates to the vertical track using (2) 1/4" - 20 x 9/16" track bolts and flanged hex nuts. Lock bars are embossed "R" for right side and "L" for left side. Place the lock bars into the slots in the secure lock base. Attach the springs to the tabs on the base and the lock bar. Position the end of the right lock bar into the slot in the right striker plate. Move the base of the secure lock back 1/8" from the edge of the section. Attach the secure lock to the section with (4) 1/4" - 20 x 11/16" self drilling screws. Repeat for the left side. Feed one end of the lock cable through the slotted hole of a lock bar and secure with (1) 1/4" - 20 x 9/16" track bolt and flanged hex nut. Pull the cable taut, but not enough to pull the lock bar out of the striker plate. While holding taut, feed the lock cable through the slotted hole of the remaining lock bar, secure with (1) 1/4" - 20 x 9/16" track bolt and flanged hex nut.

**NOTE:** Ensure that the bolt is through the front of the lock bar and the nut is on the back of the lock bar with cable going through the front of the lock bar.

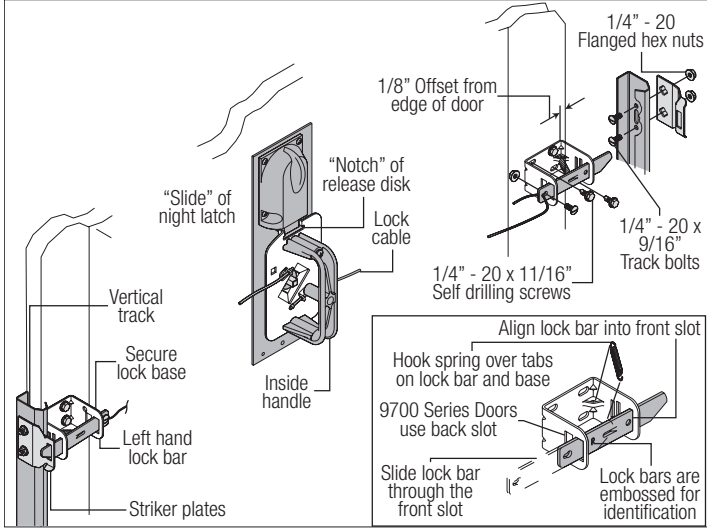

Operate the lock several times to make sure the lock bars clear the striker plates when the handle is turned and the lock bars engage the striker plates when the handle is released. Adjust the cables if necessary. Trim off the excess cable with wire cutters after the lock is operating satisfactorily.

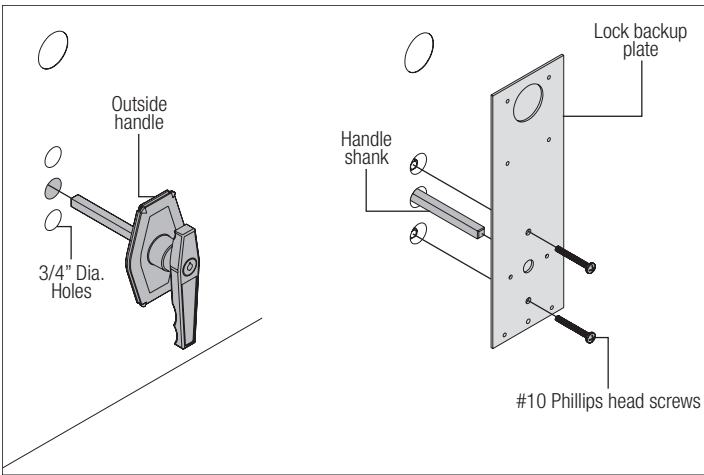

# 3 Inside Handle / Lock Assembly

Hold the disk with the large notch of the release disk pointing up. Using 1/4" - 20 carriage bolts and nylon locking nuts, fasten lock bars to disk. Do not overtighten nuts, bars must be free to rotate.

First place the 3/8" x 1" washer over the square steel shank. Hold the handle which is pointing towards the floor with one hand and place the disk assembly over the square steel shank of the outside handle. Push the retainer nut onto the shank until the free play in the assembly is taken up. Operate the lock to make sure it functions properly. If the lock operates too hard, loosen the retainer nut slightly.

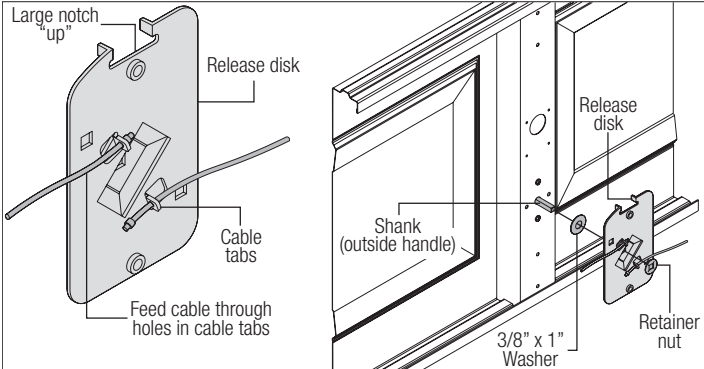

Place the inside handle over the extruded holes in the release disk. Secure the handle with (2) 1/4" - 20 x 1-3/4" self tapping screws. Insert the rim cylinder through the trim ring and into the section with the teeth side of the key pointing away from the outside handle.

Place the lock plate over the 1-1/4" diameter center stile hole and fasten with (2) #12 pan head screws into the rim cylinder. In addition, align the night latch slide with the notch in the top of the release disk. Fasten the night latch to the center stile with (4) #8 x 1/2" pan head screws.

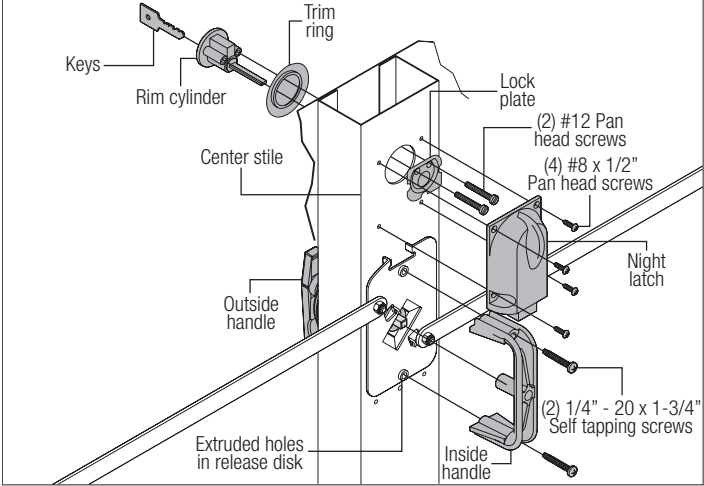

**NOTE:** Follow the Main Installation Instruction Manual to install the door sections and vertical track before you install the remainder of the lock parts. After the sections and track are installed, continue with Step 4.