

P.O. Box 67 Mt. Hope, OH., 44660 www.Wayne-Walton.com

## Astragal/Retainer Replacement

**Tools Needed:**

- Power Drill
- 7/16" Socket Driver
- Vice Clamps (Pair)
- Tin Snips
- Utility Knife

**NOTE:** This insert only pertains to the replacement of all plastic Dual Durometer Bottom Seal Astragal.

Raise the garage door so the bottom section is at a comfortable working level. Attach a vice clamp to the vertical track above the second roller on one side and below the second roller on the other side to prevent door from raising or lowering. (see Figure 1)

### **WARNING**

**FAILURE TO PLACE VICE CLAMPS ONTO VERTICAL TRACKS CAN ALLOW DOOR TO RAISE OR LOWER, POSSIBLY CAUSING SEVERE OR FATAL INJURY.**

Using a utility knife, score/cut the astragal/retainer around each of the bottom brackets of the bottom section. (see Figure 2)

**NOTE:** It may take a couple of passes with a utility knife to cut through the rigid plastic.

Remove all the fasteners across top of the astragal/retainer, and discard the old astragal/retainer. (see Figure 3).

Before you can install the new astragal/retainer, each end of the retainer will need to be notched to fit at the bottom brackets. Using a pair of tin snips/or utility knife, cut the retainer (rigid portion) 4" in from the end and 3/4" deep. (see Figure 4) Repeat for opposite end.

**IMPORTANT! WHEN NOTCHING OUT THE ENDS OF THE ASTRAGAL/RETAINER, TAKE CARE NOT TO CUT INTO THE BULB SEAL.**

Position the new astragal/retainer flush against the bottom of the bottom section and center between the bottom brackets. (see Figure 5) Attach the astragal/retainer to the bottom section with #8- 15 x 3/4" Phillips head screws, placing one 5" in from each end of the section and one every 24" (maximum) in between. (see Figure 6)

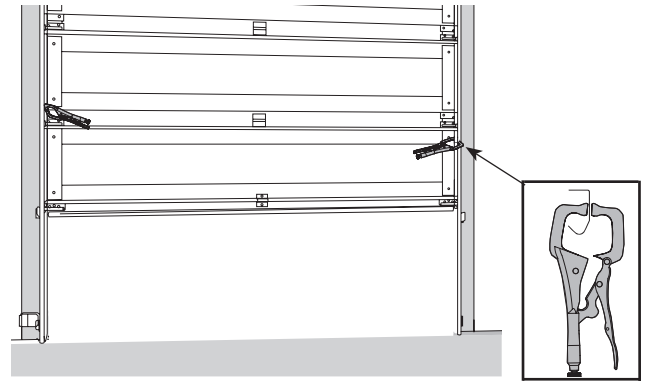

Figure 1

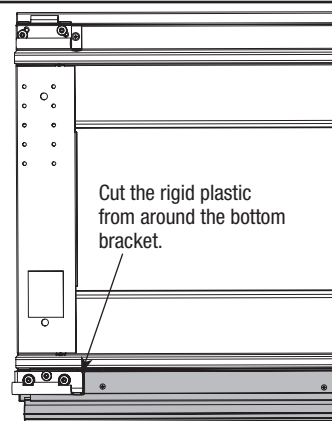
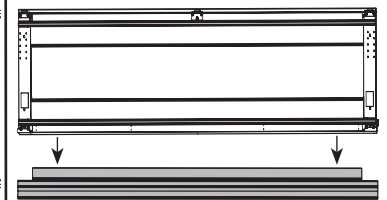

Figure 2



Astragal begin pulled off bottom panel

Figure 3

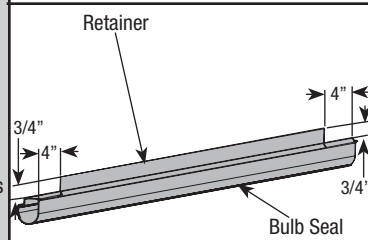

Figure 4

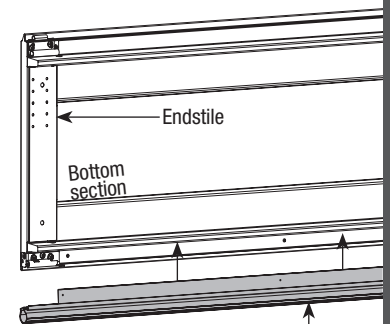

Figure 5

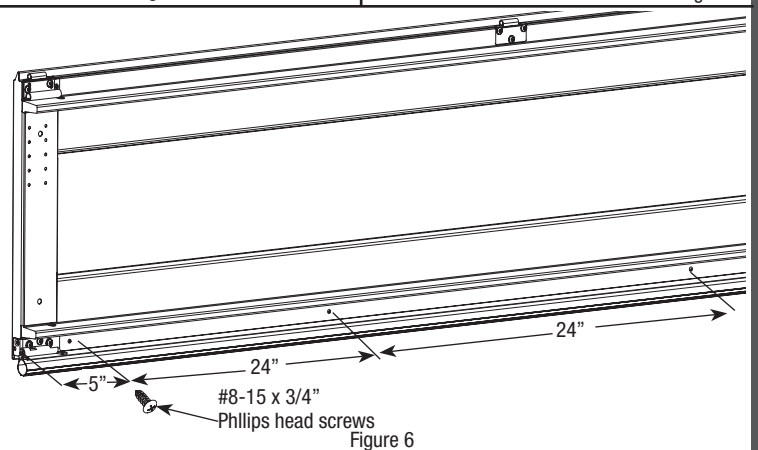

Figure 6