

INSTALLATION INSTRUCTIONS AND OWNER'S MANUAL

**Models 105, 110, 106, 116, 310, 311,
314 and 316**

FRONT MOUNT LOW HEADROOM
OUTSIDE HOOKUP

TORSION

**PLEASE DO NOT RETURN THIS PRODUCT TO
THE STORE**

If you need assistance, please call 1-866-569-3799 (press Option 1) and follow the prompts to contact a customer service representative. They will be happy to handle any questions that you may have.

IMPORTANT NOTICES!

Carefully read and fully understand the enclosed instructions before installing and operating the garage door.

Pay close attention to all warnings and notes.

After installation is complete, fasten this manual near garage door for easy reference.

This Installation document is available at no charge from:

- Your local Wayne Dalton Sales Center
- Online at **www.Wayne-Dalton.com**
- By mailing a request to: Wayne Dalton, a division of Overhead Door Corporation, P.O. Box 67, Mt. Hope, OH., 44660

Table Of Contents

PRE-INSTALLATION	3
Important Safety Instructions	3
REMOVING AN EXISTING DOOR AND PREPARING THE OPENING	5
Package Contents	6
Door Section Identification	8
Tools Required	8
BREAKDOWN OF DOOR COMPONENTS	9
BREAKDOWN OF COUNTERBALANCE COMPONENTS	10
INSTALLATION INSTRUCTIONS	11
Door Installation Instructions	11
COUNTERBALANCE INSTALLATION INSTRUCTIONS	22
OPTIONAL INSTALLATION	32
Door Arm Hookup	32
Lift Handles	32
Pull Down Rope	32
MAINTENANCE	33
Cleaning Your Garage Door	33
Painting Your Garage Door	33
Maintaining The Finish On Your Garage Door	33
Operation And Maintenance	33
WARRANTY	35

Important Safety Instructions

DEFINITION OF KEY WORDS USED IN THIS MANUAL:

DANGER

INDICATES A HAZARDOUS SITUATION THAT, IF NOT AVOIDED, WILL RESULT IN DEATH OR SERIOUS INJURY.

WARNING

INDICATES A HAZARDOUS SITUATION THAT, IF NOT AVOIDED, COULD RESULT IN DEATH OR SERIOUS INJURY.

CAUTION

INDICATES A HAZARDOUS SITUATION THAT, IF NOT AVOIDED, COULD RESULT IN MINOR OR MODERATE INJURY.

NOTICE

INDICATES INFORMATION CONSIDERED IMPORTANT, THAT IT IS NOT RELATED TO INJURY, BUT MAY RESULT IN PROPERTY DAMAGE.

IMPORTANT: Required key step for proper door operation.

NOTE: Information only.

Installation:

WARNING

INSTALLING THIS DOOR PROPERLY REQUIRES THE USE OF SPECIAL TOOLS AND TECHNIQUES. ALWAYS USE THE CORRECT TOOLS OR TECHNIQUES WHEN PERFORMING INSTALLATION. FAILURE TO USE PROPER TOOLS OR TECHNIQUES OR ADHERE TO SAFETY MESSAGES, COULD RESULT IN SEVERE OR FATAL INJURY.

DANGER

EXTREME CAUTION SHOULD BE USED WHEN WINDING SPRINGS AS FAILURE TO FOLLOW THE INSTRUCTIONS OR USE THE PROPER TOOLS CAN LEAD TO SERIOUS INJURY TO PERSONS AND PROPERTY. BEFORE ATTEMPTING TO WIND THE SPRING, MAKE SURE YOU HAVE READ AND UNDERSTAND THE INSTRUCTIONS. IF YOU ARE UNCLEAR ON ANY ASPECT OF THE INSTALLATION PROCEDURES, YOU SHOULD CONSULT A TRAINED DOOR SYSTEMS TECHNICIAN.

- READ THESE INSTRUCTIONS CAREFULLY BEFORE ATTEMPTING INSTALLATION. IF YOU ARE IN QUESTION ABOUT ANY OF THE PROCEDURES, DO NOT PERFORM THE WORK. INSTEAD, HAVE A TRAINED DOOR SYSTEMS TECHNICIAN DO THE INSTALLATION OR REPAIRS.
- Wear protective gloves and eye protection during installation, to avoid possible injury.
- **DO NOT** install door in windy conditions. Door could fall during the installation, causing severe or fatal injury.
- Doors 12'-0" wide and larger should be installed by two persons, to avoid possible injury.
- On electrically operated doors, pull down ropes must be removed and locks must be removed or made inoperative in the open (unlocked) position, unless electrical interlocks are installed.
- Impact guns are not recommended. When installing 5/16" lag screws using an electric drill/ driver, the drill/ drivers clutch must be set to deliver no more than 200 in-lbs of torque. Fastener failure could occur at higher settings.
- Check with your local building official for wind load code requirements and building permit information.
- For windloaded doors, the wind performance is achieved via the entire door system and component substitution is not authorized without express permission by the manufacturer.

CAUTION

IF ANY PART OF THE DOOR IS TO BE INSTALLED ONTO PRESERVATIVE-TREATED WOOD, PTFE-COATED OR STAINLESS STEEL FASTENERS MUST BE OBTAINED AND USED. REPLACEMENT FASTENERS MUST BE OF AT LEAST EQUAL STRENGTH AND SIZE AS ORIGINAL FASTENERS. IF THE ORIGINAL FASTENER WAS RED-HEAD, THE REPLACEMENT FASTENER MUST BE RED-HEAD ALSO. CONTACT WAYNE DALTON FOR FASTENER STRENGTH VALUES IF NEEDED.

Operation:

⚠ WARNING

TO PREVENT DEATH OR SERIOUS INJURY WHILE OPERATING THE DOOR, ENSURE THE PATH OF THE DOOR IS NOT OBSTRUCTED BY ANY PERSON OR OBJECT AND ADHERE TO THE FOLLOWING SAFETY MEASURES.

- Operate door only when it is properly adjusted and free from obstructions.
- If a door becomes hard to operate, inoperative or is damaged, immediately have necessary adjustments and/ or repairs made by a trained door system technician using proper tools and instructions.
- **DO NOT** stand or walk under a moving door, or permit anybody to stand or walk under an electrically operated door.
- **DO NOT** place fingers or hands into open section joints when closing a door. Use lift handles/ gripping points when operating door manually.
- **DO NOT** permit children to operate garage door or door controls. Severe or fatal injury could result should the child become entrapped between the door and the floor.
- Visually inspect door and hardware monthly for worn and or broken parts. Check to ensure door operates freely. Test electric opener's safety features monthly, following opener manufacturer's instructions.
- **NEVER** hang tools, bicycles, hoses, clothing or anything else from horizontal tracks. Track systems are not intended or designed to support extra weight.

Potential Hazard	Effect	Prevention
 <p>Moving door</p>	<p>⚠ WARNING</p> <p>Could result in Death or Serious Injury</p>	<p>Keep people clear of opening while Door is moving.</p> <p>Do NOT allow children to play with the Door Opener.</p> <p>Do NOT operate a Door that jams or one that has a broken spring.</p>
 <p>High tension spring</p>	<p>⚠ DANGER</p> <p>Will result in Death or Serious Injury</p>	<p>Do NOT try to remove, install, repair or adjust springs or anything to which door spring parts are fastened, such as, wood blocks, steel brackets, cables or other like items.</p> <p>Installations, repairs and adjustments must be done by a trained door system technician using proper tools and instructions.</p>

IMPORTANT: RIGHT and LEFT hand is determined inside the building looking out.

REMOVING AN EXISTING DOOR AND PREPARING THE OPENING

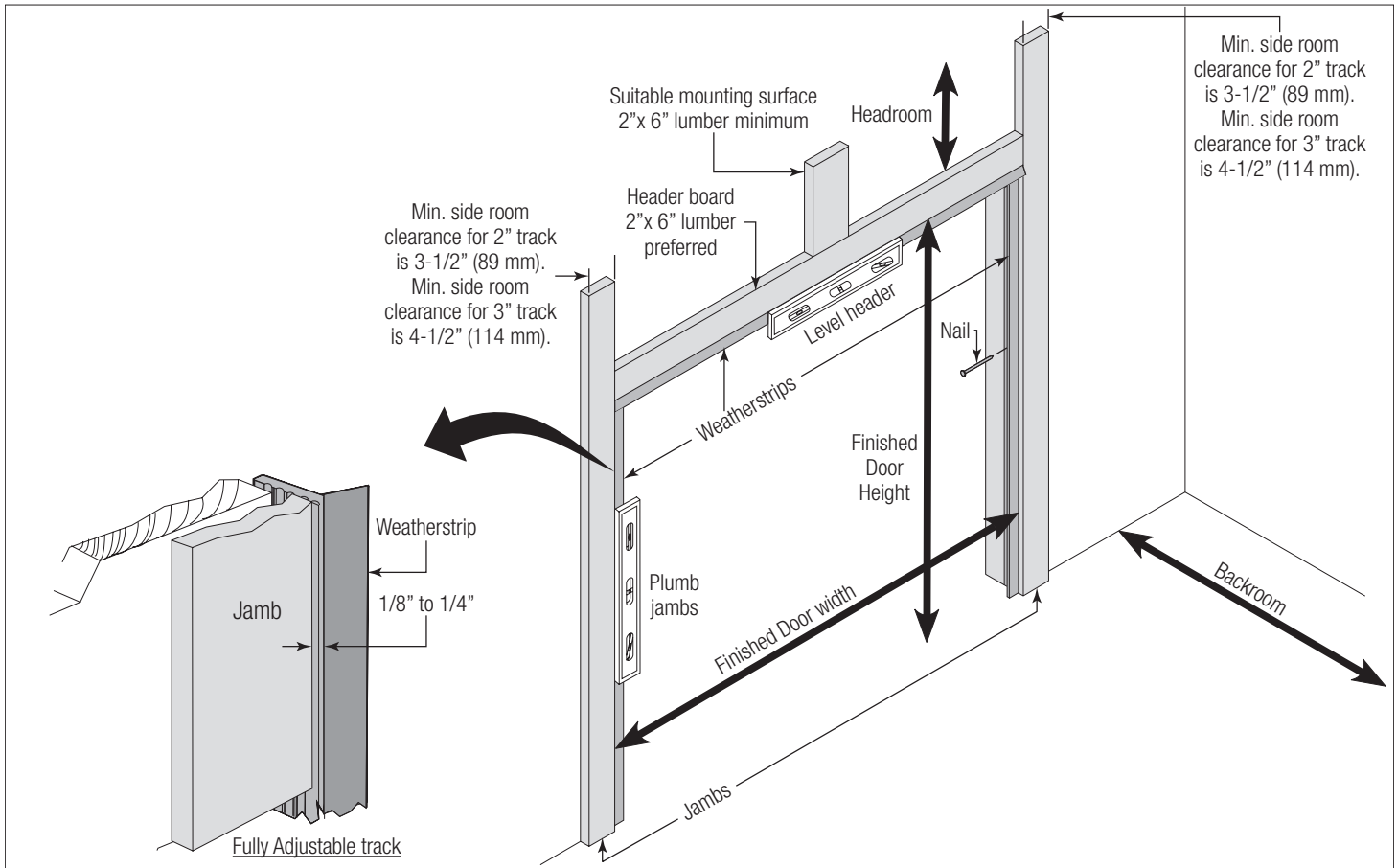

Figure 1

! DANGER

AVOID INJURY! A POWERFUL SPRING RELEASING ITS ENERGY SUDDENLY CAN CAUSE SEVERE OR FATAL INJURY. ALWAYS HAVE A TRAINED DOOR SYSTEMS TECHNICIAN, USING PROPER TOOLS AND INSTRUCTIONS, RELEASE THE SPRING TENSION.

! WARNING

TO AVOID POSSIBLE INJURY AND TO ENSURE PROPER INSTALLATION, IT'S HIGHLY RECOMMENDED THAT YOU READ AND FULLY UNDERSTAND THE COMPLETE INSTRUCTIONS ON REMOVING AN EXISTING DOOR & PREPARING THE OPENING. THESE ARE AVAILABLE FOR DOWNLOAD AT WWW.WAYNE-DALTON.COM OR AT YOUR LOCAL WAYNE DALTON SALES CENTER.

! DANGER

COUNTERBALANCE SPRING TENSION MUST ALWAYS BE RELEASED BEFORE ANY ATTEMPT IS MADE TO START REMOVING AN EXISTING DOOR. EXTREME CAUTION SHOULD BE USED WHEN UNWINDING SPRINGS AS FAILURE TO FOLLOW THE INSTRUCTIONS OR USE PROPER TOOLS CAN LEAD TO SERIOUS INJURY.

See Figure 1 for the following steps.

To ensure secure mounting of track brackets, side and center brackets, or steel angles to new or retro-fit construction, it is recommended to follow the procedures outlined in DASMA technical data sheets #156, #161 and #164 at www.dasma.com.

- The inside perimeter of your garage door opening should be framed with wood jamb and header material.
- The jambs and header must be securely fastened to sound framing members. It is recommended that 2" x 6" lumber be used. The jambs must be plumb and the header level.
- The jambs should extend a minimum of 12" (305 mm) above the top of the opening for Torsion counterbalance systems.
- For low headroom applications, the jambs should extend to the ceiling height. Minimum side clearance required, from the opening to the wall, is 3-1/2" (89 mm).

NOTICE

CLOSELY INSPECT JAMBS, HEADER AND MOUNTING SURFACE. ANY WOOD FOUND NOT TO BE SOUND, MUST BE REPLACED.

For Torsion counterbalance systems, a suitable mounting surface (2" x 6") must be firmly attached to the wall, above the header at the center of the opening.

NOTICE

DRILL A SUITABLE PILOT HOLE IN THE MOUNTING SURFACE TO AVOID SPLITTING THE LUMBER. DO NOT ATTACH THE MOUNTING SURFACE WITH NAILS.

Weatherstrips (Not Included):

Depending on the size of your door, you may have to cut or trim the weatherstrips to properly fit into the header and jambs.

NOTICE

IF NAILING PRODUCT AT 40°F, (4.4°C) OR BELOW, PRE-DRILLING IS REQUIRED.

1. For the header, align the weatherstrip with the inside edge of the header and temporarily secure it to the header with equally spaced nails, approximately 12" to 18" (305 mm - 457 mm) apart.

2. Starting at either side of the jamb, fit the weatherstrip up tight against the temporarily attached weatherstrip in the header and flush with the inside edge of the jamb.

3. Temporarily secure the weatherstrip with equally spaced nails. Repeat for other side. This will keep the bottom door section from falling out of the opening during installation.

Headroom requirement:

Headroom required is defined as the space needed above the top of the door for tracks, springs, etc. to allow the door to open properly.

NOTE: 6" low headroom conversion kit is available for 12" radius only. Contact your local Wayne Dalton dealer.

If the door is to be motor operated, 2-1/2" (64 mm) of additional headroom is required.

TRACK TYPE	SPACE NEEDED
6" LHR	9" (229 mm)

Backroom requirement:

Backroom required is defined as the distance needed from the opening back into the garage to allow the door to open fully.

***NOTE:** For door heights from 10'1" to 14'0", refer to your operator manufacture installation instructions for appropriate depth into room.

DOOR HEIGHT	TRACK	MANUAL LIFT	MOTOR OPERATED
6'0" to 7'0"	15" Radius	102" (2591 mm)	125" (3175 mm)
7'1" to 8'0"	15" Radius	114" (2896 mm)	137" (3480 mm)
8'1" to 9'0"	15" Radius	126" (3200 mm)	168" (4267 mm)
9'1" to 10'0"	15" Radius	138" (3505 mm)	168" (4267 mm)
10'1" to 12'0"	15" Radius	162" (4115 mm)	See *NOTE

Package Contents

NOTE: Depending on the door model, some parts listed may not be required, and will not be supplied.

Components and Hardware

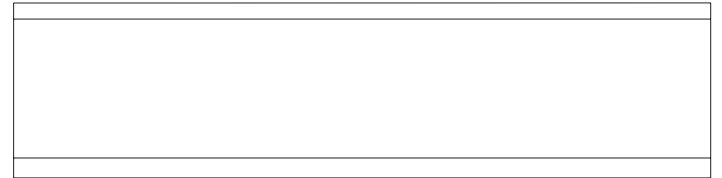

(E1. - E3.) Door sections (as required)



(M9.) Torsion shaft / Torsion keyed shaft (as required)



(M10.) Torsion keyed shafts (as required)

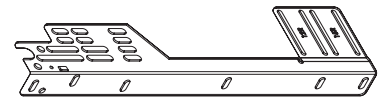

(A1.) Fully Adjustable flag angles RH/LH (as required)

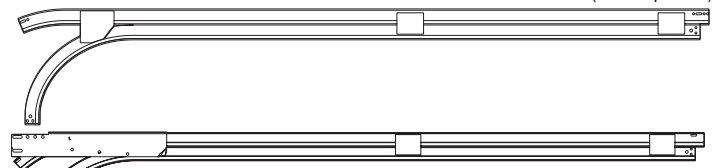

(H1.) Horizontal tracks (as required)



(H2.) Vertical tracks RH/LH (as required)



(H3.) Riveted vertical track assemblies RH/LH (as required)



(H4.) Angle mount vertical track assemblies RH/LH (as required)

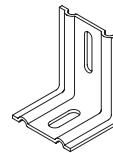

(B1.) F.A. jamb brackets (as required)

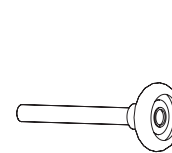

(C1.) (C2.) Track rollers (as required)

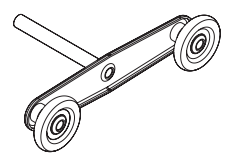

(C3.) (C4.) Tandem track rollers (as required)

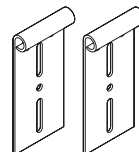

(F1.) Top Fixtures (as required)

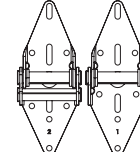

(D1.) (D2.) Graduated hinges (as required)



(J1.) Bottom weather seal

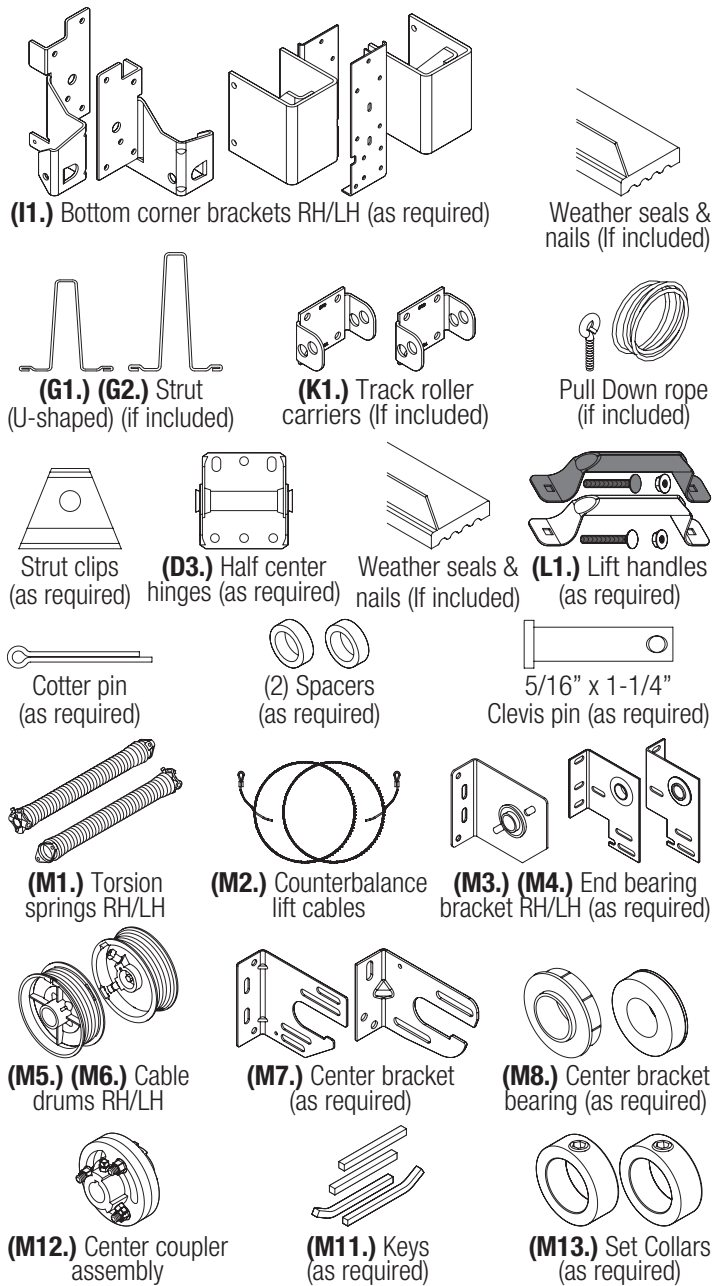

Figure 2

Fasteners

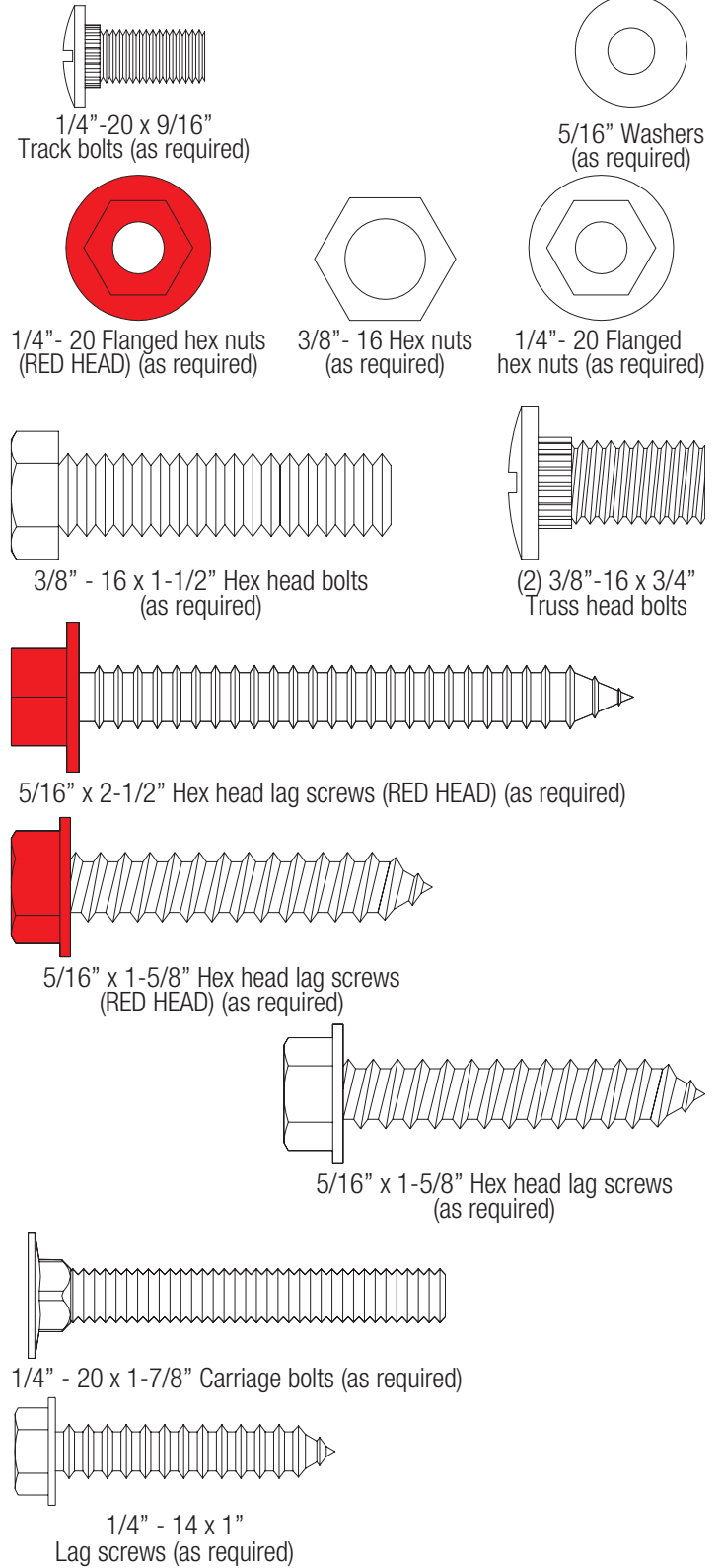

Figure 3

Door Section Identification

See Figure 4 for the following steps.

When installing your door, you must use sections of the appropriate height in the right stacking location. Determine, what sections you need to use in what order depends on the design of your door.

Sections are stamped for identification, #1, #2, #3, #4, #5, #6, and #7. The stamp, located on each side of the sections identifies the stacking sequence. The sequence is always determined by #1 being the bottom section to #6 or #7 being the highest top section. If the stamp on the section is illegible, refer to the section side view illustration. The section side view illustration shows the section profile of all sections, and can also be used to identify each section.

The **BOTTOM SECTION** can be identified by #1.

The **INTERMEDIATE I SECTION** can be identified by #2.

The **INTERMEDIATE II SECTION** can be identified by #3, for a 4 section high door only.

The **INTERMEDIATE III SECTION** can be identified by #4, for a 5 section high door only.

The **INTERMEDIATE VI SECTION** can be identified by #5, for a 6 section high door only.

The **INTERMEDIATE V SECTION** can be identified by #6, for a 7 section high door only.

The **TOP SECTION** can be identified by a #, being the highest section.

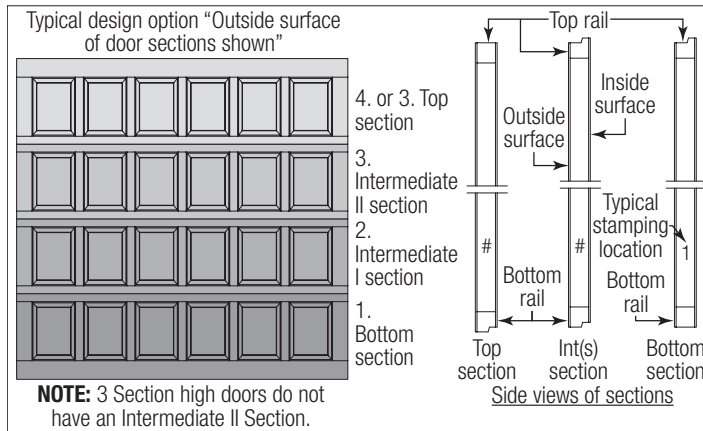

Figure 4

Tools Required

Personal Protection Equipment (PPE)



Figure 5

Hand Tools

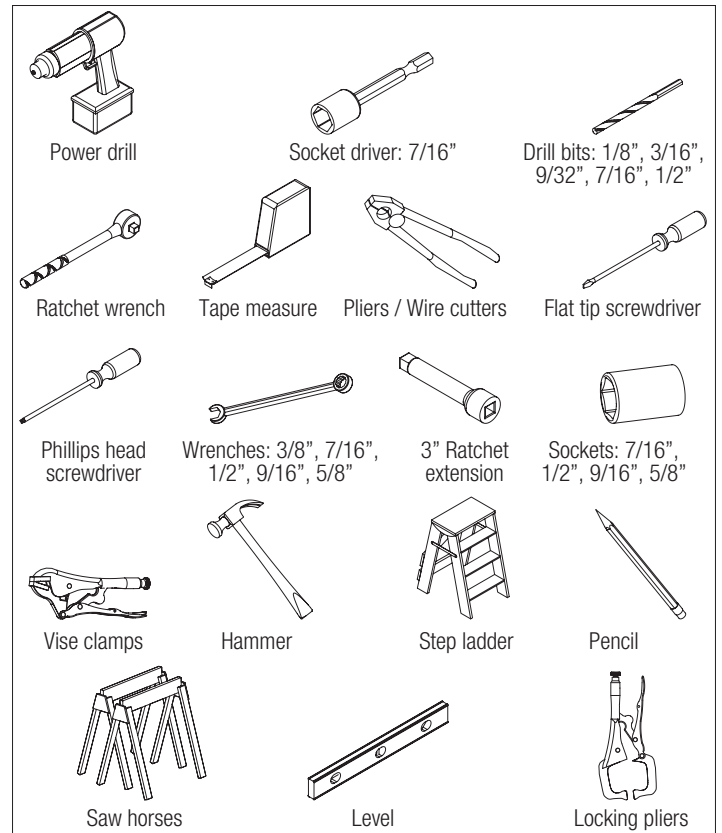

Figure 6

BREAKDOWN OF DOOR COMPONENTS

NOTE: The illustrations shown on this page are general representations of the door parts. Each specific door models may have unique variations.

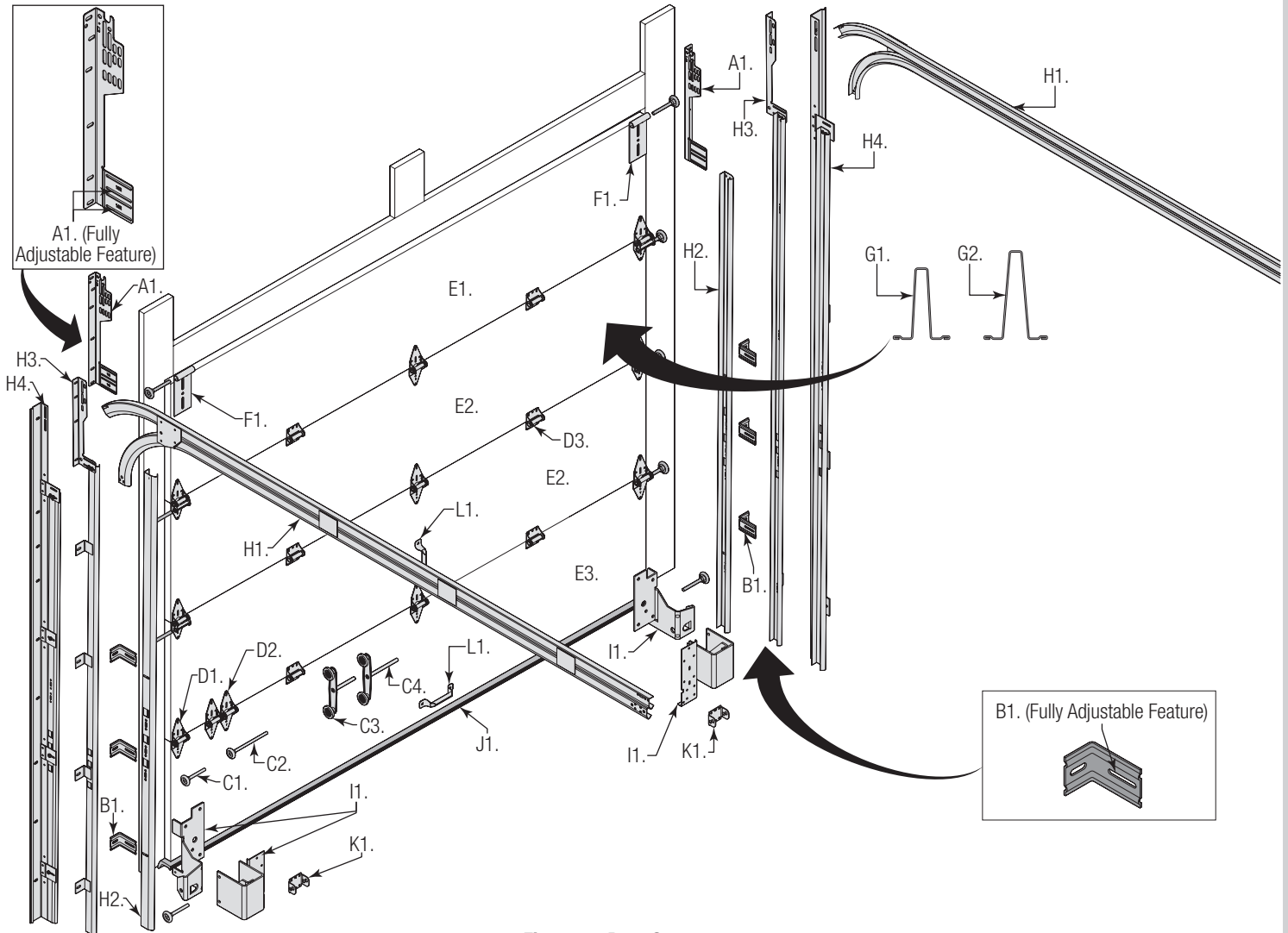

Figure 7 - Door Components

A. FLAG ANGLES (AS REQUIRED):

- A1. Fully Adjustable (F.A.) Flag Angles

B. JAMB BRACKETS (AS REQUIRED):

- B1. Fully Adjustable (F.A.) Jamb Brackets

C. TRACK ROLLERS (AS REQUIRED):

- C1. Short Stem Track Rollers
- C2. Long Stem Track Rollers
- C3. Short Stem Tandem Track Rollers
- C4. Long Stem Tandem Track Rollers

D. GRADUATED END HINGES:

- D1. Single Graduated End Hinges (S.E.H.), Industry Standard
- D2. Double Graduated End Hinges (D.E.H.), Industry Standard
- D3. Half Center Hinges (As required)

E. STACKED SECTIONS:

- E1. Top Section
- E2. Intermediate(s) Section
- E3. Bottom Section

F. TOP FIXTURES (AS REQUIRED):

- F1. Top Fixtures

G. STRUT(S) (AS REQUIRED):

- G1. Strut (2" U-shaped)
- G2. Strut (3" U-shaped)

H. TRACKS (AS REQUIRED):

- H1. Left Hand and Right Hand Horizontal Track Assemblies
- H2. Left Hand and Right Hand Vertical Tracks
- H3. Left Hand and Right Hand Riveted Vertical Track Assemblies
- H4. Left Hand and Right Hand Angle Mount Vertical Track Assemblies

I. BOTTOM CORNER BRACKETS (AS REQUIRED):

- I1. Left Hand and Right Hand Bottom Corner Brackets

J. BOTTOM WEATHER SEAL (AS REQUIRED):

- J1. Bottom Weather Seal (Door Width), (Nails Not Supplied)

K. TRACK ROLLER CARRIERS (AS REQUIRED):

- K1. Track Roller Carriers

L. LIFT HANDLES:

- L1. Lift Handles

BREAKDOWN OF COUNTERBALANCE COMPONENTS

NOTE: The illustrations shown on this page are general representations of the door parts. Each specific door models may have unique variations.

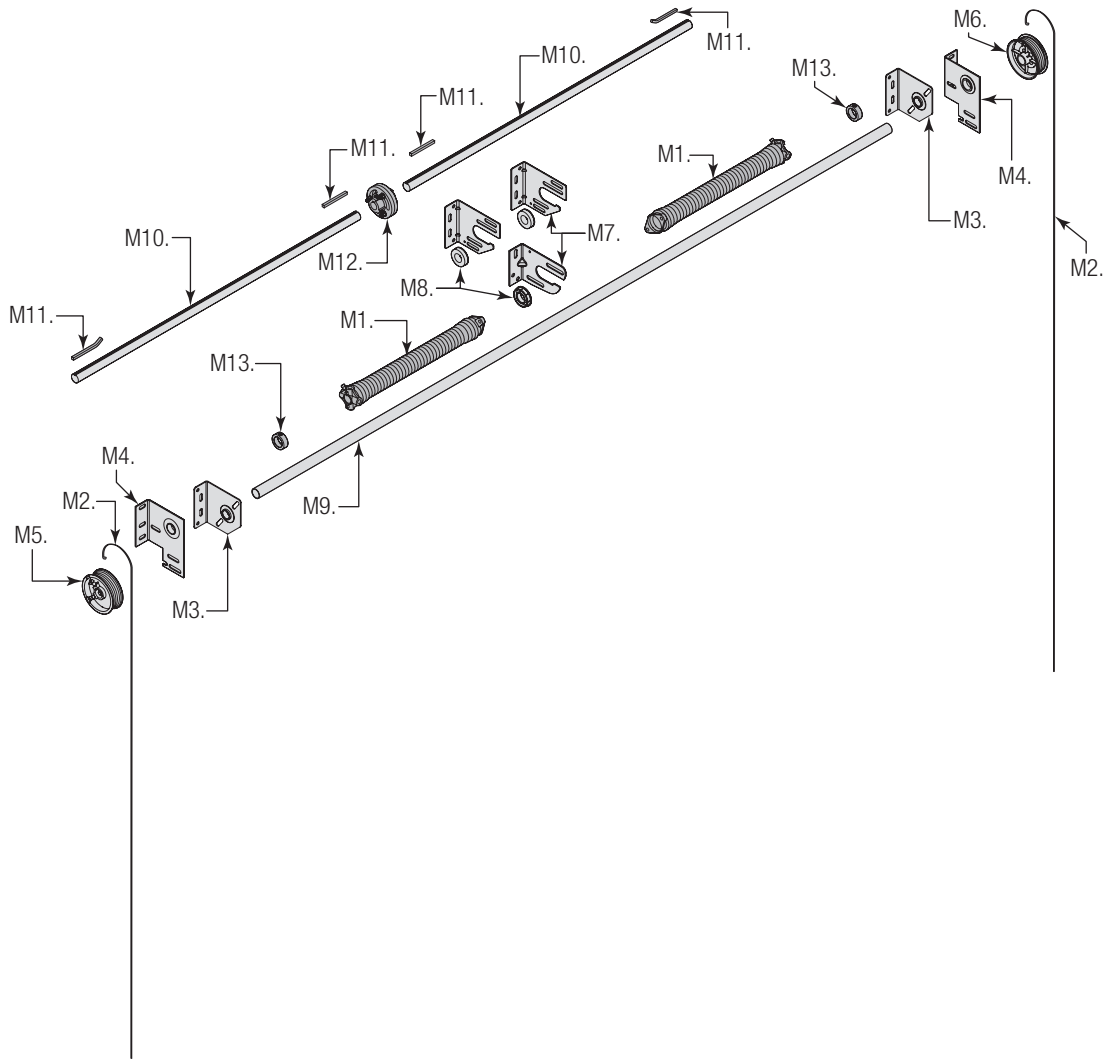

Figure 7 - Counterbalance Components

M. TORSION SPRING ASSEMBLY (AS REQUIRED):

- M1. Left Hand and Right Hand Torsion Springs (As Required)
- M2. Counterbalance Lift Cables
- M3. Left Hand and Right Hand End Bearing Bracket (As Required)
- M4. Left Hand and Right Hand End Bearing Bracket (As Required)
- M5. Left Hand Cable Drum
- M6. Right Hand Cable Drum
- M7. Center Bracket(s) (As Required)
- M8. Center Bracket Bearing(s) (As Required)
- M9. Torsion Shaft / Torsion Keyed Shaft (As Required)
- M10. Torsion Keyed Shafts (As Required)
- M11. Keys (As Required)
- M12. Center Coupler Assembly (As Required)
- M13. Set Collars (As Required)

INSTALLATION INSTRUCTIONS

Door Installation Instructions

BEFORE INSTALLING YOUR DOOR, BE CERTAIN THAT YOU HAVE READ AND FOLLOWED ALL OF THE INSTRUCTIONS COVERED IN THE PRE-INSTALLATION SECTION OF THIS MANUAL. FAILURE TO DO SO MAY RESULT IN AN IMPROPERLY INSTALLED DOOR.

IMPORTANT: Reference TDS 160 for general garage door terminology at www.dasma.com.

IMPORTANT: Wood doors must be completely finished (3 total coats, including primer coat) prior to installation, to ensure that the interior and exterior surfaces, as well as all edges of the doors are properly protected against moisture or other contaminants. Wood doors, in a non-finished condition, must be transported and stored so the wood surfaces are NOT exposed to moisture or other contaminants. Improper transportation, storage or delays in finishing, that allows exposure of the wood door surfaces to moisture or other contaminants will result in the warranty being voided.

1 VERTICAL TRACK ASSEMBLY

IMPORTANT: If you have Riveted Track or Angle Mount Track, skip this step.

NOTE: Refer to Package Contents or Breakdown Of Parts, to determine which type of jamb bracket you received.

NOTE: For clarity, all graphics shown are of the left side, right side will be the same.

IMPORTANT: The bottom jamb bracket is always the shortest bracket, while the center jamb bracket is the next tallest. If three jamb brackets per side are included with your door, you will have received a top jamb bracket, which is the tallest.

For Doors With Fully Adjustable Flag Angle:

See Figure 8 and Figure 9 for the following steps.

IMPORTANT: Each flag angle will have a unique ID "12R or 15R". Measure the radius of your horizontal track to determine if your horizontal track is 12" or 15" Radius.

1a. Hand tighten the flag angle ① to the vertical track ② using two 1/4" - 20 x 9/16" track bolts ③ and two 1/4" - 20 flange hex nuts ④.

1b. attach the shortest jamb bracket ⑤ by aligning the slot in the shortest jamb bracket with the lower hole of the hole/ slot pattern of the vertical track. Hand tighten the jamb bracket using (1) 1/4" - 20 x 9/16" track bolt and (1) 1/4" - 20 flange hex nut.

1c. Place the tallest jamb bracket ⑥ over the lower hole of the hole/ slot pattern that is centered between the bottom jamb bracket and flag angle of the 2nd hole set. Hand tighten the jamb bracket using (1) 1/4" - 20 x 9/16" track bolt and (1) 1/4" - 20 flange hex nut.

1d. Repeat this process for the right hand side.

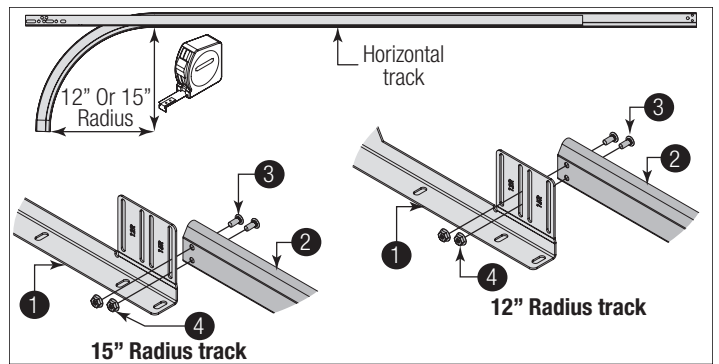

Figure 8, Left Side Shown

IMPORTANT: In Figure 8, observe the slot location in reference to the 12" or 15" radius.

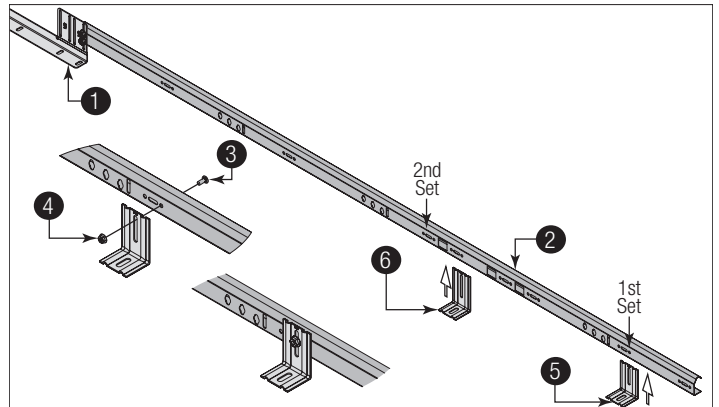

Figure 9, Left Side Shown

1	Flag Angle	4	1/4" - 20 Flange Hex Nut
2	Vertical Track	5	Shortest Jamb Bracket
3	1/4" - 20 x 9/16" Track Bolt	6	Tallest Jamb Bracket

2 ATTACHING BOTTOM WEATHER SEAL

NOTE: Refer to door section identification, located in the pre-installation section of this manual to determine what size section you need to use as your bottom (first) section. Measure your section to make sure it is the correct height as indicated on the chart.

IMPORTANT: Reference Package Contents or Breakdown Of Parts, to determine if a bottom weather seal was supplied. If a bottom weather seal was supplied, complete this step.

NOTE: Verify that the bottom weather seal is aligned with bottom section. If needed, trim the bottom weather seal even with bottom section length.

See Figure 10 for the following steps.

2a. Place the bottom section ① face down on a couple of sawhorses or flat clean/ smooth surface.

2b. Align the bottom weather seal ② with the flap ③ pointing towards the outside surface of the bottom section.

2c. Starting at one end of the door, measure inward 1" ④ and attach the bottom weather seal to the bottom of the bottom section with 3/4" long galvanized roofing nails (not supplied) ⑤.

2d. Now stretch the bottom weather seal slightly and nail the rest of the bottom weather seal to the bottom of the bottom section every 6" ⑥.

2e. Once the bottom weather seal is fastened cut off any extra material so that the bottom weather seal is even with both ends of the bottom section.

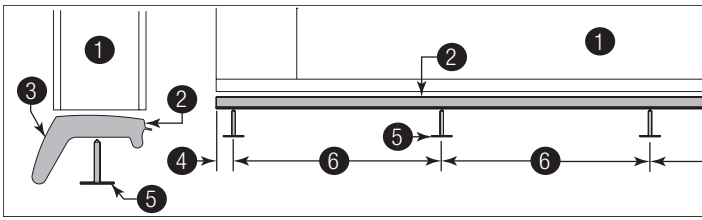

Figure 10

1	Bottom Section	4	1"
2	Bottom Weather Seal	5	3/4" Long Galvanized Roofing Nails (Not Supplied)
3	Flap	6	6"

3 ATTACHING BOTTOM CORNER BRACKETS

IMPORTANT: Refer to door section identification, located in the pre-installation section of this manual or refer to Breakdown of Parts.

NOTE: Refer to Package Contents / Breakdown of Parts, to determine which bottom corner brackets you have.

! WARNING

ENSURE TIGHT FIT OF CABLE LOOP OVER PIN TO PREVENT COUNTERBALANCE LIFT CABLE FROM COMING OFF THE PIN, WHICH COULD ALLOW THE DOOR TO FALL AND RESULT IN DEATH OR SERIOUS INJURY.

IMPORTANT: The carriage bolts and the 1/4" - 20 RED HEAD flange hex nuts must be installed through the holes of the bottom corner brackets, as shown.

NOTE: Check to ensure cable loop fits tightly over the pins.

See Figure 11 through Figure 13 for the following steps.

3a. Uncoil ① the counterbalance lift cables ②.

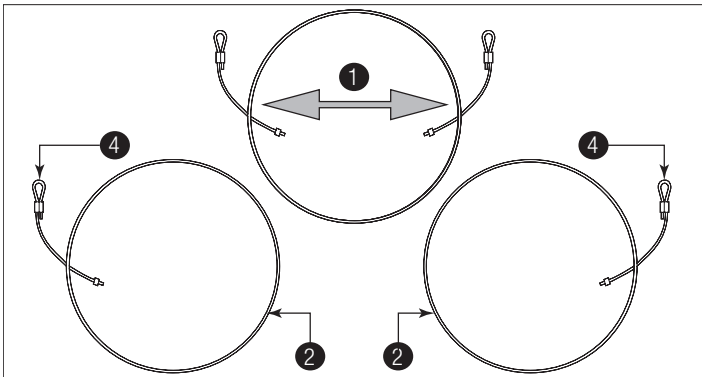

Figure 11

3b. Starting on the left hand bottom corner bracket ③, secure the cable loop ④ to the clevis pin ⑤ and bottom corner bracket using a flat washer ⑥ and a cotter pin ⑦.

3c. Repeat for other bottom corner bracket.

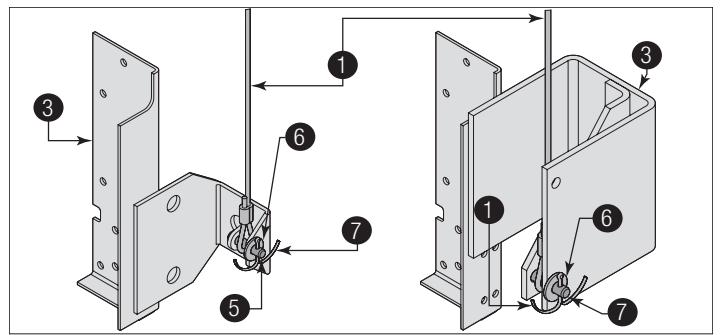

Figure 12, Left Side Shown

3d. Locate the left hand bottom corner bracket. Align the bottom corner bracket horizontally with the bottom edge of the bottom section and align the bottom corner bracket vertically with the left bottom edge of the bottom section.

3e. Mark and pre-drill 9/32" diameter holes through the bottom section.

3f. Attach the bottom corner bracket to the bottom section using 1/4" - 20 x 1-7/8" carriage bolts ⑧, three 1/4" - 20 RED HEAD flange hex nuts ⑨ and a 1/4" - 20 flange hex nut ⑩.

3g. Repeat the same process for the right hand side.

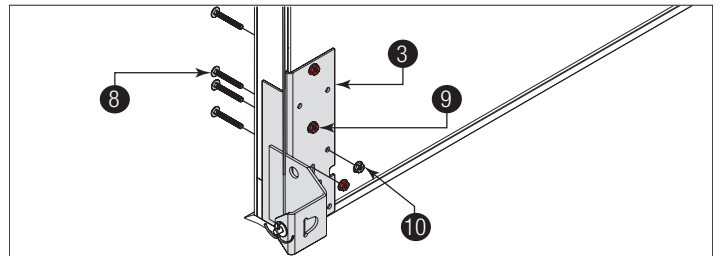

Figure 13, Left Side Shown

1	Uncoil	6	Flat Washer
2	Counterbalance Lift Cables	7	Cotter Pin
3	Bottom Corner Brackets	8	1/4" - 20 x 1-7/8" Carriage Bolts
4	Cable Loop	9	1/4" - 20 RED HEAD Flange Hex Nuts
5	Pin	10	1/4" - 20 Flange Hex Nuts

4 ATTACHING TRACK ROLLER CARRIER'S

IMPORTANT: If you don't have track roller carriers, then skip this step. Refer to Package Contents / Breakdown of Parts, to determine if a track roller carrier was supplied with your door.

IMPORTANT: The track roller carrier's inner holes are used on doors with 2" track applications ①; the outer holes are used on doors with 3" track applications ②.

NOTE: Prior to fastening the track roller carrier to the bottom section, pilot drill using a 1/8" drill bit.

IMPORTANT: Be extremely careful not to drill thru the section. Only drill 1" deep.

See Figure 14 and Figure 15 for the following steps.

4a. Starting on left hand side of the bottom section ③, attach the track roller carrier ④ with the stamp "STD" facing UP ⑤ to the bottom corner bracket by aligning the four holes of the track roller carrier with the four holes in the bottom corner bracket.

4b. Secure the track roller carrier to the bottom corner bracket using 1/4" - 14 x 1" lag screws 6.

4c. Repeat for the other track roller carrier and repeat the same process for the right hand side.

4d. Insert a short stem track roller 7 and roller spacer 8 into the appropriate inner / outer holes of the track roller carrier.

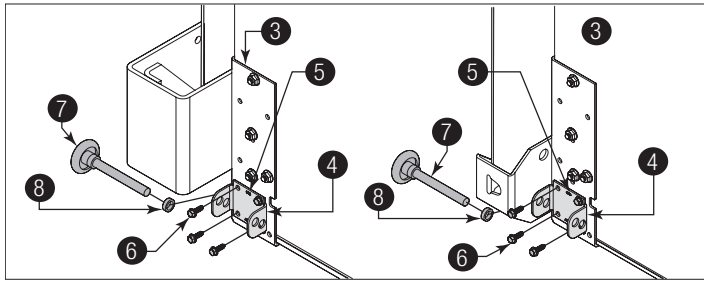

Figure 14, Left Side Shown

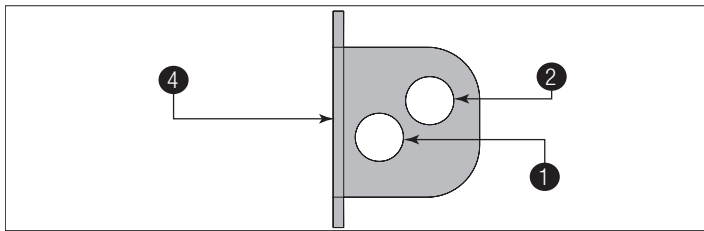

Figure 15, Left Side Shown

1	2" Track Applications	5	"STD" Facing UP
2	3" Track Applications	6	1/4" - 14 x 1" Lag Screws
3	Bottom Section	7	Short Stem Track Roller
4	Track Roller Carrier	8	Roller Spacer

5 ATTACHING HINGES AND STRUT TO BOTTOM SECTION

NOTE: Refer to the Bottom Section Short Strut Strutting Schedule below, to determine the appropriate strutting for your Bottom section.

NOTE: Prior to fastening the strut to the bottom section, pilot drill using a 1/8" drill bit.

IMPORTANT: Be extremely careful not to drill thru the section. Only drill 1" deep.

Door Models	Door Width			Location On Bottom Section
	Up To and Including 12'2"	From 12'3" To 16'0"	From 16'1" To 18'0"	
105 / 106	N/A	(1) Short	N/A	Bottom Of Section
110 / 116		(1) Short		
310 / 311 / 314 / 316		(1) Short		

Bottom Section Short Strut Strutting Schedule For Door Heights Greater Than Or Equal to 8'1"

Door Models	Door Width			Location On Bottom Section
	Up To and Including 12'2"	From 12'3" To 16'0"	From 16'1" To 18'0"	
105 / 106	(1) Short		N/A	Bottom Of Section
110 / 116	(1) Short			
310 / 311 / 314 / 316	(1) Short			

See Figure 16 through Figure 22 for the following steps.

5a. Lay a **SHORT STRUT** 1 onto the bottom rail of the bottom section 2. Position the bottom of the strut 3/4" 3 up from the bottom edge of the bottom section. Center the short strut from side to side on the section surface.

5b. Drill pilot holes, 1" deep into the bottom section using a 1/8" drill bit.

5c. Attach the strut using (1) 1/4" - 14 x 1" lag screw 4 at each pre-drilled hole.

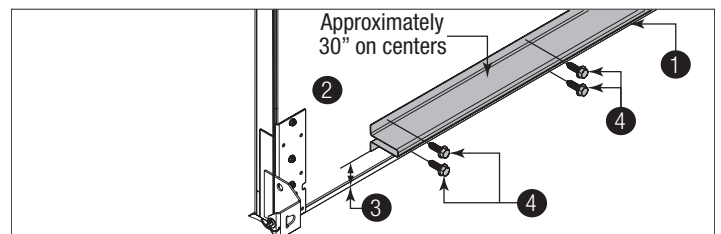

Figure 16, Left Side Shown

1	Short Strut	3	3/4"
2	Bottom Section	4	1/4" - 14 X 1" Lag Screw

NOTE: Refer to the Bottom Section Graduated End Hinge Schedule below, to determine the appropriate hinges for your bottom section.

Door Height	Section Type	Track	Graduated End Hinge Number
3 Through 7 Section High Doors	Bottom	2"	#1
		3"	#3

NOTE: Refer to the Bottom Section Long Strut Strutting Schedule below, to determine the appropriate strutting for your Bottom section.

Door Models	Door Width			Location On Bottom Section
	Up To and Including 12'2"	From 12'3" To 16'0"	From 16'1" To 18'0"	
105 / 106	N/A	(1) Long	N/A	Top Of Section
110 / 116		(1) Long	(1) Long	
310 / 311 / 314 / 316		(1) Long	(1) Long	

NOTE: Center hinge(s) use #1 graduated end hinges at each pre-drilled or vertical stile location. The pre-drilled locations are located at the top rails on the inside of the section surface.

NOTE: Some struts also may or may not have holes in them. If they don't, then prior to installing the strut and hinge to the section surface, you may have to drill a 3/16" hole for the appropriate fastener on one or both sides of the strut legs.

5d. Using the appropriate graduated end hinges for the ends and depending on the width of your door, enough center hinge(s) for each pre-drilled hole location(s). Starting at the upper left hand corner of the bottom section. Position the lower hinge leaf of the appropriate graduated end hinge onto the upper corner of the bottom section. Align the slots of the lower hinge leaf with the pre-drilled holes in the bottom section. If applicable, lay a **Long Strut** 5 over the lower hinge leaf and over the top rail of the bottom section. Center the long strut from side to side.

For Graduated End Hinges Without A Long Strut:

5e. Attach the upper slot of the graduated end hinge 6 to the bottom section using (1) 1/4" - 20 x 1-7/8" carriage bolt 7 and (1) 1/4" - 20 flange hex nut 8.

5f. Secure the lower hole of the graduated end hinge to the bottom section using (1) 1/4" - 20 x 1-7/8" carriage bolt and (1) 1/4" - 20 flange hex nut.

5g. Repeat for other side.

If You Have Double Graduated End Hinges Without A Long Strut:

5e. Position the second graduated end hinge 9 next to the first (single) graduated end hinge. Using the second graduated end hinge as a template, drill pilot holes, 1" deep into the bottom section using a 1/8" drill bit.

5f. Secure the graduated end hinge to the bottom section using (2) 1/4" - 14 x 1" lag screws 4.

5g. Repeat for other side.

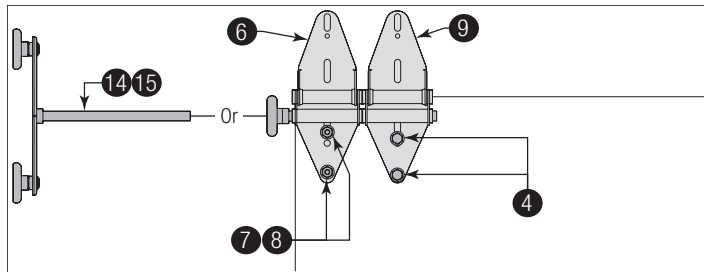

Figure 17, Left Side Shown

For Graduated End Hinges With A Long Strut:

5e. Attach the upper leg of the strut, (1) strut clip 10 to the upper slot of the graduated end hinge 6 to the bottom section 2 using (1) 1/4" - 20 x 1-7/8" carriage bolt 7 and (1) 1/4" - 20 flange hex nut 8.

5f. Secure the lower leg of the strut, (1) strut clip to the lower hole of the graduated end hinge to the bottom section using (1) 1/4" - 20 x 1-7/8" carriage bolt and (1) 1/4" - 20 flange hex nut.

5g. Repeat for other side.

If You Have Double Graduated End Hinges With A Long Strut:

5e. Position the second graduated end hinge 9 next to the first (single) graduated end hinge. Using the second graduated end hinge as a template, drill pilot holes, 1" deep into the bottom section using a 1/8" drill bit.

5f. Secure the graduated end hinge to the bottom section using (2) 1/4" - 14 x 1" lag screws 4.

5g. Repeat for other side.

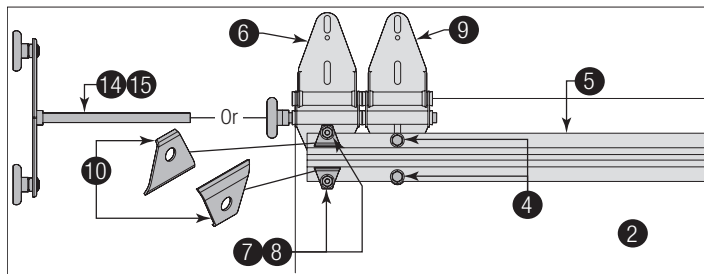

Figure 18, Left Side Shown

For Center Hinges Without A Long Strut:

5h. Attach the upper slot of the center hinge 11 to the bottom section using (1) 1/4" - 20 x 1-7/8" carriage bolt 7 and (1) 1/4" - 20 flange hex nut 8.

5i. Secure the lower hole of the center hinge to the bottom section using (1) 1/4" - 20 x 1-7/8" carriage bolt and (1) 1/4" - 20 flange hex nut.

5j. Repeat for other center hinge(s).

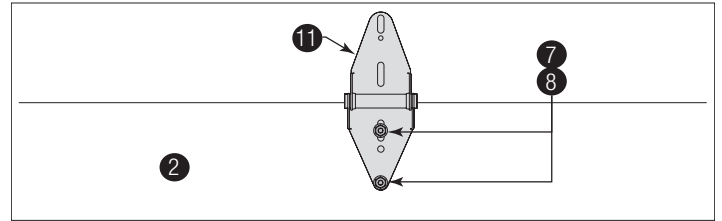

Figure 19

For Center Hinges With A Long Strut:

5h. Attach the upper leg of the strut, (1) strut clip 10 to the upper slot of the center hinge 11 to the bottom section using (1) 1/4" - 20 x 1-7/8" carriage bolt 7 and (1) 1/4" - 20 flange hex nut 8.

5i. Secure the lower leg of the strut, (1) strut clip to the lower hole of the center hinge to the bottom section using (1) 1/4" - 20 x 1-7/8" carriage bolt and (1) 1/4" - 20 flange hex nut.

5j. Repeat for other center hinge(s).

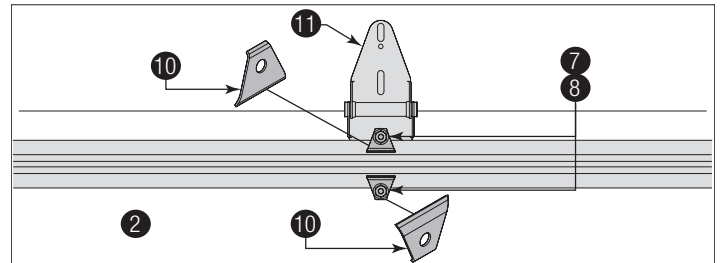

Figure 20

NOTE: If you don't have half center hinges, then skip this part of the step. Refer to Package Contents / Breakdown Of Parts, to determine if you have half center hinges.

5k. Using a tape measure, position the half center hinges 12 equally spaced 13 in between the center hinges and the graduated end hinges.

5l. Position the holes of the lower hinge leaf at the top rail of the bottom section. Using the half center hinge as a template, drill pilot holes, 1" deep into the bottom section with a 1/8" drill bit (if needed).

5m. Attach the lower hinge leaf of the center hinge to the bottom section using (2) 1/4" - 14 x 1" lag screws 4. Repeat for other half center hinge(s).

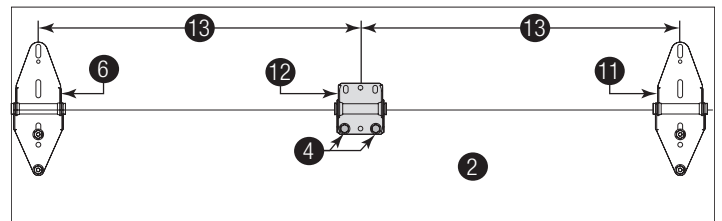

Figure 21

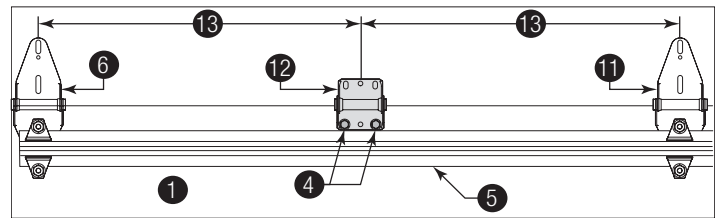

Figure 22

If you have single graduated end hinges, insert a short stem track roller / short stem tandem track roller (if included) 14 into the hinge tube on each side.

If you have double graduated end hinges, insert a long stem track roller / short stem tandem track roller (if included) 15 into the hinge tubes on each side.

IMPOTANT: When placing track rollers / tandem track roller (if included) into graduated end hinges number 2 and higher, the track roller / tandem track roller (if included) goes into tube furthest away from section.

4	1/4" - 14 x 1" Lag Screw	10	Strut Clip
5	Long Strut	11	Center Hinge
6	Graduated End Hinge	12	Half Center Hinge
7	1/4" - 20 x 1-7/8" Carriage Bolt	13	Equally Spaced
8	1/4" - 20 Flange Hex Nut	14	Short Stem Track Roller / Short Stem Tandem Track Roller
9	Second Graduated End Hinge	15	Long Stem Track Roller / Short Stem Tandem Track Roller

6 ATTACHING HINGES AND STRUT TO INTERMEDIATE SECTION(S)

NOTE: Refer to door section identification, located in the pre-installation section of this manual to determine what size section you need to use as your intermediate I (second), intermediate II (third), intermediate III (fourth), Intermediate IV (fifth), Intermediate V (sixth) and if applicable Intermediate VI (seventh). Measure your section to make sure it is the correct height as indicated on the chart.

NOTE: Refer to the Graduated End Hinge Schedule below, to determine the appropriate hinges for your Intermediate section(s).

3 Section High Graduated End Hinge Schedule			
Door Height	Track	Section Type	Graduated End Hinge Number
3 Section High Door	2"	Intermediate I	#2
	3"	Intermediate I	#4

4 Section High Graduated End Hinge Schedule			
Door Height	Track	Section Type	Graduated End Hinge Number
4 Section High Door	2"	Intermediate II	#3
		Intermediate I	#2
	3"	Intermediate II	#5
		Intermediate I	#4

5 Section High Graduated End Hinge Schedule			
Door Height	Track	Section Type	Graduated End Hinge Number
5 Section High Door	2"	Intermediate III	#4
		Intermediate II	#3
		Intermediate I	#2
	3"	Intermediate III	#6
		Intermediate II	#5
		Intermediate I	#4

6 Section High Graduated End Hinge Schedule			
Door Height	Track	Section Type	Graduated End Hinge Number
6 Section High Door	2"	Intermediate IV	#5
		Intermediate III	#4
		Intermediate II	#3
		Intermediate I	#2
	3"	Intermediate IV	#7
		Intermediate III	#6
		Intermediate II	#5
		Intermediate I	#4

7 Section High Graduated End Hinge Schedule			
Door Height	Track	Section Type	Graduated End Hinge Number
7 Section High Door	2"	Intermediate V	#6
		Intermediate IV	#5
		Intermediate III	#4
		Intermediate II	#3
		Intermediate I	#2
	3"	Intermediate V	#8
		Intermediate IV	#7
		Intermediate III	#6
		Intermediate II	#5
		Intermediate I	#4

NOTE: Refer to the Strutting Schedules below, to determine the appropriate strutting for your Intermediate(s) section. Measure the height of the long strut(s) to determine if you have 2" or 3".

Intermediate Section Strutting Schedule For Door Heights Less Than Or Equal to 8'0"				
Door Models	Door Width			Location On Intermediate Section
	Up To and Including 12'2"	From 12'3" To 16'0"	From 16'1" To 18'0"	
105 / 106	N/A	(1) Long Strut per Intermediate II Section	N/A	Top Of Section
110 / 116		(1) Long Strut per Intermediate II Section		
310 / 311 / 314 / 316		(1) Long Strut per Intermediate II Section		

Intermediate Section Strutting Schedule For Door Heights Greater Than Or Equal to 8'1"				
Door Models	Door Width			Location On Intermediate Section
	Up To and Including 12'2"	From 12'3" To 16'0"	From 16'1" To 18'0"	
105 / 106	N/A	(1) Long Strut per Intermediate Section	N/A	Top Of Section
110 / 116		(1) Long Strut per Intermediate Section		
310 / 311 / 314 / 316		(1) Long Strut per Intermediate Section		

NOTE: Center hinge(s) use #1 graduated end hinges at each pre-drilled or vertical stile location. The pre-drilled locations are located at the top rails on the inside of the section surface.

NOTE: Some struts also may or may not have holes in them. If they don't, then prior to installing the strut and hinge to the section surface, you may have to drill a 3/16" hole for the appropriate fastener on one or both sides of the strut legs.

NOTE: Prior to fastening the hinges to the section, pilot drill using a 1/8" drill bit.

IMPORTANT: Be extremely careful not to drill thru the section. Only drill 1" deep.

See Figure 23 through Figure 28 for the following steps.

6a. Place the Intermediate section face down on a couple of sawhorses or flat clean/ smooth surface. Using the appropriate graduated end hinges **1** for the ends and depending on the width of your door, enough center hinge(s) **2** for each pre-drilled hole location(s).

6b. Starting at the upper left hand corner of the Intermediate section **3**, position the lower hinge leaf of the appropriate graduated end hinge onto the upper corner of the Intermediate section.

6c. Align the slots of the lower hinge leaf with the pre-drilled holes in the Intermediate section. If applicable, lay a **Long Strut 4** over the lower hinge leaf and over the top rail of the Intermediate section. Center the long strut from side to side.

For Graduated End Hinges Without A Long Strut:

6d. Attach the upper slot of the graduated end hinge to the Intermediate section using (1) 1/4" - 20 x 1-7/8" carriage bolt **5** and (1) 1/4" - 20 flange hex nut **6**.

6e. Secure the lower hole of the graduated end hinge to the Intermediate section using (1) 1/4" - 20 x 1-7/8" carriage bolt and (1) 1/4" - 20 flange hex nut.

6f. Repeat for other side.

If You Have Double Graduated End Hinges Without A Long Strut:

6d. Position the second graduated end hinge **7** next to the first (single) graduated end hinge. Using the second graduated end hinge as a template, drill pilot holes, 1" deep into the Intermediate section using a 1/8" drill bit.

6e. Secure the graduated end hinge to the Intermediate section using (2) 1/4" - 14 x 1" lag screws **8**.

6f. Repeat for other side.

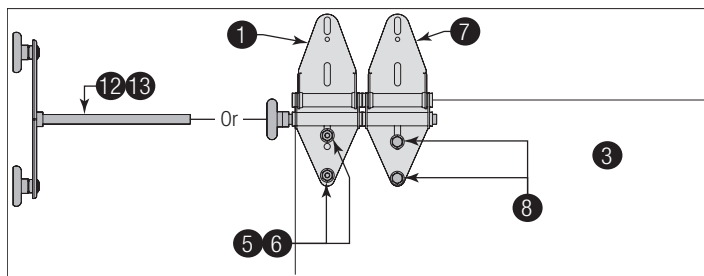

Figure 23

For Graduated End Hinges With A Long Strut:

6g. Attach the upper leg of the strut, (1) strut clip **9** to the upper slot of the graduated end hinge to the Intermediate section using (1) 1/4" - 20 x 1-7/8" carriage bolt and (1) 1/4" - 20 flange hex nut.

6h. Secure the lower leg of the strut, (1) strut clip to the lower hole of the graduated end hinge to the Intermediate section using (1) 1/4" - 20 x 1-7/8" carriage bolt and (1) 1/4" - 20 flange hex nut.

6i. Repeat for other side.

If You Have Double Graduated End Hinges With A Long Strut:

6g. Position the second graduated end hinge next to the first (single) graduated end hinge. Using the second graduated end hinge as a template, drill pilot holes, 1" deep into the Intermediate section using a 1/8" drill bit.

6h. Secure the graduated end hinge to the Intermediate section using (2) 1/4" - 14 x 1" lag screws.

6i. Repeat for other side.

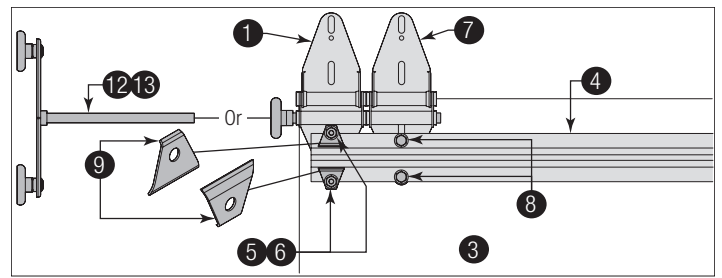

Figure 24

For Center Hinges Without A Long Strut:

6j. Attach the upper slot of the center hinge to the Intermediate section using (1) 1/4" - 20 x 1-7/8" carriage bolt and (1) 1/4" - 20 flange hex nut.

6k. Secure the lower hole of the center hinge to the Intermediate section using (1) 1/4" - 20 x 1-7/8" carriage bolt and (1) 1/4" - 20 flange hex nut.

6l. Repeat for other center hinge(s).

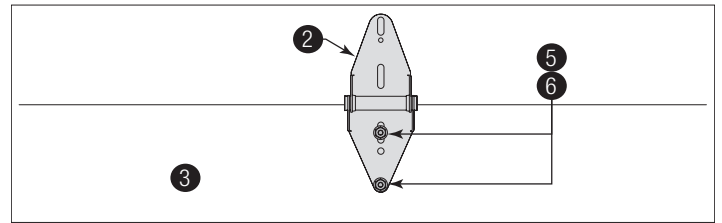

Figure 25

For Center Hinges With A Long Strut:

6j. Attach the upper leg of the strut, (1) strut clip of the center hinge to the Intermediate section using (1) 1/4" - 20 x 1-7/8" carriage bolt and (1) 1/4" - 20 flange hex nut.

6k. Secure the lower leg of the strut, (1) strut clip to the lower hole of the center hinge to the Intermediate section using (1) 1/4" - 20 x 1-7/8" carriage bolt and (1) 1/4" - 20 flange hex nut.

6l. Repeat for other center hinge(s).

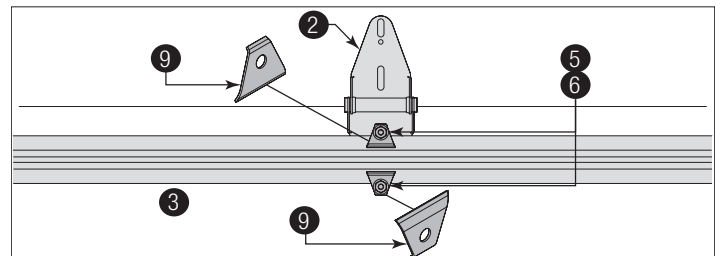

Figure 26

NOTE: If you don't have half center hinges, then skip this part of the step. Refer to Package Contents / Breakdown Of Parts, to determine if you have half center hinges.

6m. Using a tape measure, position the half center hinges **10** equally spaced **11** in between the center hinges and the graduated end hinges.

6n. Position the holes of the lower hinge leaf at the top rail of the bottom section. Using the half center hinge as a template, drill pilot holes, 1" deep into the Intermediate section with a 1/8" drill bit.

6o. Attach the lower hinge leaf of the center hinge to the Intermediate section using (2) 1/4" - 14 x 1" lag screws.

6p. Repeat for other half center hinge(s).

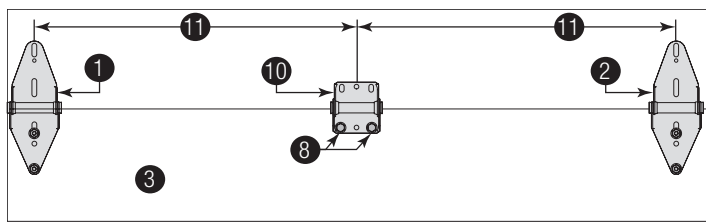

Figure 27

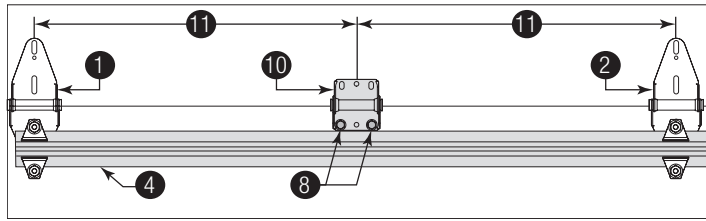

Figure 28

6q. If you have single graduated end hinges, insert a short stem track roller / short stem tandem track roller 12 (if included) into the hinge tube on each side.

6q. If you have double graduated end hinges, insert a long stem track roller / long stem tandem track roller 13 (if included) into the hinge tubes on each side.

IMPORTANT: When placing track rollers / tandem track roller (if included) into graduated end hinges number 2 and higher, the track roller / tandem track roller (if included) goes into tube furthest away from section.

6r. If applicable, repeat the same process for the other Intermediate sections, except for the top section.

1	Graduated End Hinge	8	1/4" - 14 x 1" Lag Screw
2	Center Hinge	9	Strut Clip
3	Intermediate Section	10	Half Center Hinge
4	Long Strut	11	Equally Spaced
5	1/4" - 20 x 1-7/8" Carriage Bolt	12	Short Stem Track Roller / Short Stem Tandem Track Roller
6	1/4" - 20 Flange Hex Nut	13	Long Stem Track Roller / Long Stem Tandem Track Roller
7	Second Graduated End Hinge		

7

ATTACHING TOP FIXTURES AND STRUT TO TOP SECTION

NOTE: Refer to door section identification, located in the pre-installation section of this manual to determine what size section you need to use as your top section. Measure your section to make sure it is the correct height as indicated on the chart.

NOTE: Refer to the Top Section Short Strut Strutting Schedule below, to determine the appropriate strutting for your Top section.

Top Section Short Strut Strutting Schedule For Door Heights Less Than Or Equal to 8'0"

Door Models	Door Width			Location On Top Section
	Up To and Including 12'2"	From 12'3" To 16'0"	From 16'1" To 18'0"	
105 / 106	N/A	(1) Short	N/A	Top Of Section
110 / 116		(1) Short		
310 / 311 / 314 / 316		(1) Short		

Top Section Short Strut Strutting Schedule For Door Heights Greater Than Or Equal to 8'1"

Door Models	Door Width			Location On Top Section
	Up To and Including 12'2"	From 12'3" To 16'0"	From 16'1" To 18'0"	
105 / 106	(1) Short		N/A	Top Of Section
110 / 116	(1) Short			
310 / 311 / 314 / 316	(1) Short			

See Figure 29 through Figure 31 for the following steps.

7a. Place the top section 1 face down on a couple of sawhorses or flat clean/ smooth surface.

7b. Lay a **Short Strut** 2 onto the top rail of the top section. Position the top of the strut 3/4" 3 downward from the top edge of the top section.

7c. Center the short strut from side to side on the section surface. Drill pilot holes, 1" deep into the top section using a 1/8" drill bit.

IMPORTANT: Be extremely careful not to drill thru the section. Only drill 1" deep.

Attach the strut using (1) 1/4" - 14 x 1" lag screw 4 at each pre-drilled hole.

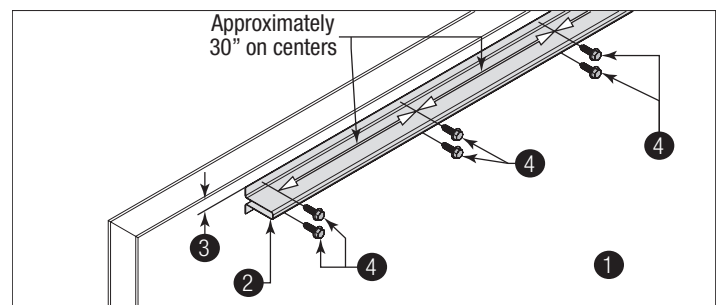

Figure 29

NOTE: If your door came with two top fixtures, then one top fixture and a short stem track roller 5 are required for each side.

NOTE: If your door came with four top fixtures, then two top fixtures and a long stem track roller 6 are required for each side.

7d. Starting on the left hand side, align the edge of the top fixture 7 parallel to the top section edge.

7e. Using the top fixture base as a template, mark and pre-drill (2) 9/32" diameter holes through the top section.

7f. Loosely attach the top fixture base to the top section using (2) 1/4" - 20 x 1-7/8" carriage bolts and 8 (2) 1/4" - 20 flange hex nuts 9.

7g. Repeat the same process for the right hand side.

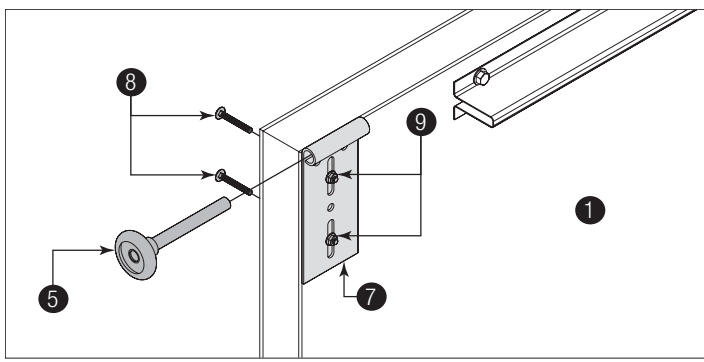

Figure 30

If You Have Four Top Fixtures:

7h. Position the second top fixture 10 next to the first installed top fixture assembly.

7i. Using the top fixture base as a template, drill pilot holes, 1" deep into the top section with a 1/8" drill bit (if needed).

IMPORTANT: Be extremely careful not to drill thru the section. Only drill 1" deep.

7j. Loosely attach the top fixture base to the top section using (2) 1/4" - 14 x 1" lag screws.

7k. Repeat the same process for the right hand side.

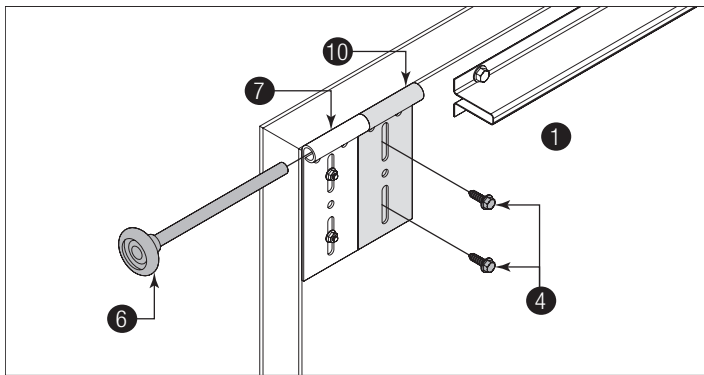

Figure 31

1	Top Section	6	Long Stem Track Roller
2	Short Strut	7	Top Fixture
3	3/4"	8	1/4" - 20 x 1-7/8" Carriage Bolt
4	1/4" - 14 x 1" Lag Screw	9	1/4" - 20 Flange Hex Nut
5	Short Stem Track Roller	10	Second Top Fixture

8 POSITIONING BOTTOM SECTION

See Figure 32 for the following steps.

8a. Center the bottom section 1 in the door opening.

8b. Use a level 2 and wood shims 3 (if necessary) to level the bottom section. When the bottom section is leveled, temporarily hold it in place by driving a nail into the jamb and bending it over the edge of the bottom section on both sides.

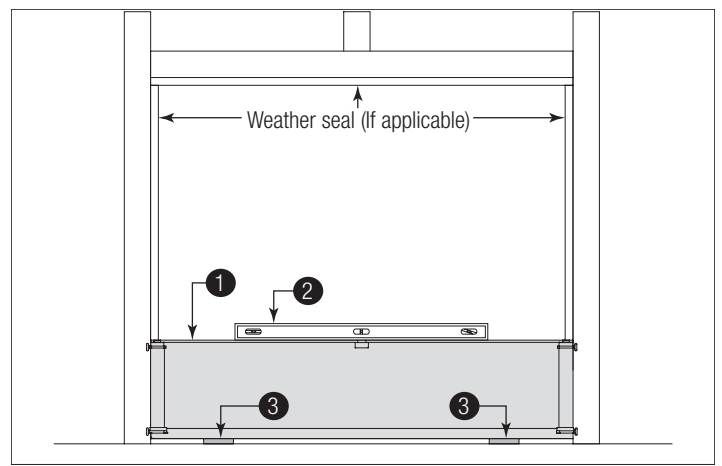

Figure 32

1	Bottom Section	3	Wood Shims
2	Level		

9 ATTACHING VERTICAL TRACKS TO JAMBS

IMPORTANT: Depending on your door, you may have Fully Adjustable Flag Angles, Riveted Vertical Track Assemblies or you may have Angle Mount Vertical Track Assemblies. Refer to Package Contents / Breakdown of Parts, to determine which Flag Angles / Vertical Track Assemblies you have.

IMPORTANT: If this door is to be installed prior to a finishing construction of the building's floor, the vertical tracks and the door bottom section assembly should be installed such that when the floor is constructed, no door or track parts are trapped in the floor construction.

IMPORTANT: If the bottom section was leveled with shims, the vertical track on the shimmed side must be raised the same height as the shim. Recheck the top of the vertical tracks to be level from side to side.

IMPORTANT: Make sure the counterbalance lift cable is located between the track rollers and the door jamb.

See Figure 33 through Figure 35 for the following steps.

9a. Starting on the left hand side of the bottom section 1, remove the nail. Position the left hand vertical track assembly 2 over the track rollers of the bottom section and install, as shown. Drill 3/16" pilot holes into the door jamb for the lag screws.

IMPORTANT: For proper flag angle lag screw location, note the flag angle styles 3.

For Doors With Fully Adjustable Flag Angles:

9b. Loosely fasten jamb brackets 4 and flag angle 5 to the jamb using 5/16" x 1-5/8" lag screws 6.

9c. Tighten lag screws, securing the bottom jamb bracket to jamb, maintain 3/8" to 5/8" spacing for 2" track or 1/2" to 3/4" for 3" track spacing 7, between the bottom section and vertical track.

9d. Hang counterbalance lift cable over flag angle. Repeat same process for other side.

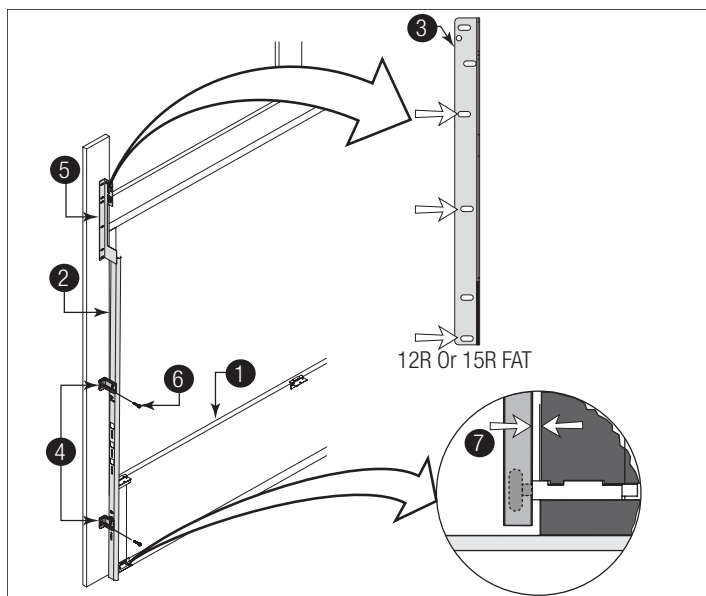

Figure 33, Left Side Shown

For Doors With Riveted Vertical Track Assemblies:

9b. Loosely fasten jamb brackets 4 and flag angle 5 to the jamb using 5/16" x 1-5/8" lag screws 6.

9c. Tighten lag screws, securing the bottom jamb bracket to jamb, maintain 3/8" to 5/8" spacing for 2" track or 1/2" to 3/4" for 3" track spacing 7 as shown, between the bottom section and vertical track.

9d. Hang counterbalance lift cable over flag angle. Repeat same process for other side.

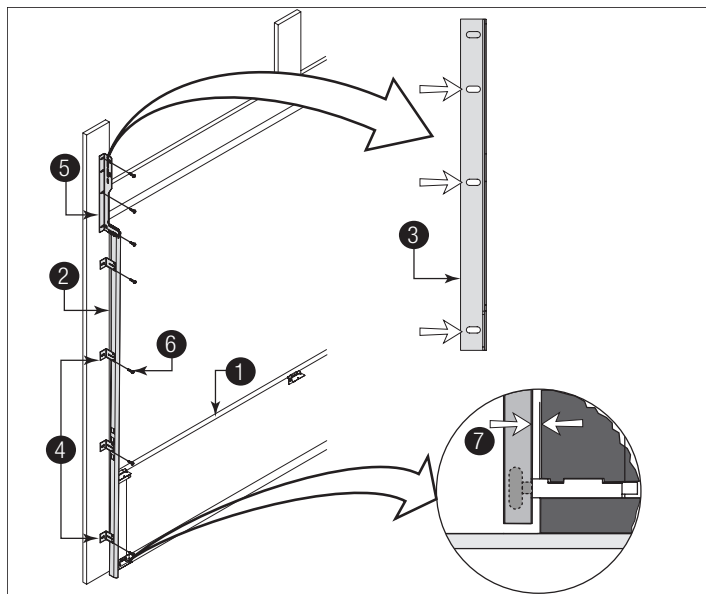

Figure 34, Left Side Shown

1	Bottom Section	5	Flag Angle
2	Vertical Track Assembly	6	5/16" x 1-5/8" Lag Screws
3	Flag Angle Styles	7	3/8" To 5/8" Spacing For 2" Track Or 1/2" To 3/4" For 3" Track Spacing
4	Jamb Brackets		

For Doors With Angle Mount Vertical Track Assemblies:

9b. Loosely fasten the slots 2 in the angle mount 3 to the jamb using 5/16" x 1-5/8" lag screws 4.

9c. Tighten lag screws, securing the bottom slot 5 in the angle mount, maintain 3/8" to 5/8" spacing for 2" track or 1/2" to 3/4" for 3" track spacing 6 as shown, between the bottom section and vertical track.

9d. Hang counterbalance lift cable over angle mount. Repeat same process for other side.

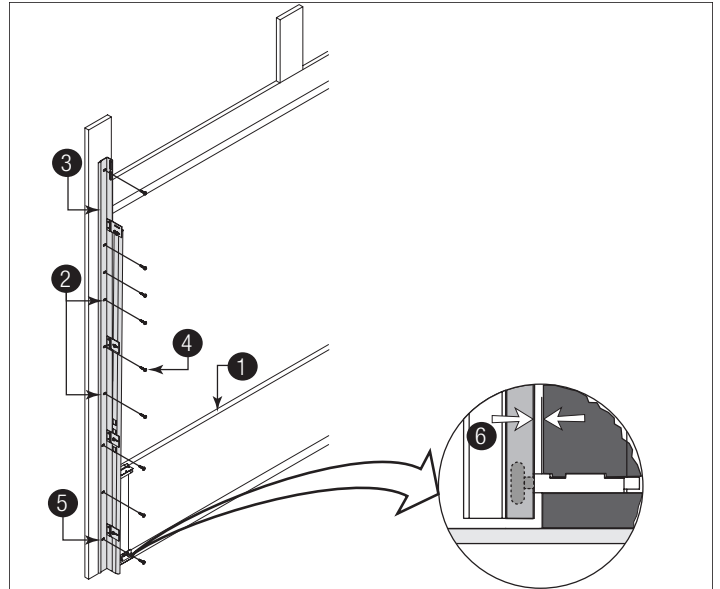

Figure 35, Left Side Shown

1	Bottom Section	4	5/16" x 1-5/8" Lag Screws
2	Slots	5	Bottom Slot
3	Angle Mount	6	3/8" To 5/8" Spacing For 2" Track Or 1/2" To 3/4" For 3" Track Spacing

10 STACKING SECTIONS

NOTE: Refer to door section identification, located in the pre-installation section of this manual to determine what size section you need to use as your intermediate I (second), intermediate II (third), intermediate III (fourth), Intermediate IV (fifth) and if applicable Intermediate V (sixth). Measure your section to make sure it is the correct height as indicated on the chart.

NOTICE

BEFORE STACKING SECTIONS, MAKE SURE GRADUATED END AND CENTER HINGES 1 ARE FLIPPED DOWN 2 TO AVOID POSSIBLE DAMAGE TO YOUR DOOR, WHEN STACKING ANOTHER SECTION ON TOP.

See Figure 36 through Figure 38 for the following steps.

10a. With assistance, lift second section 3 and guide the track rollers into the vertical tracks 4.

10b. Lower section until it is seated against bottom section 5.

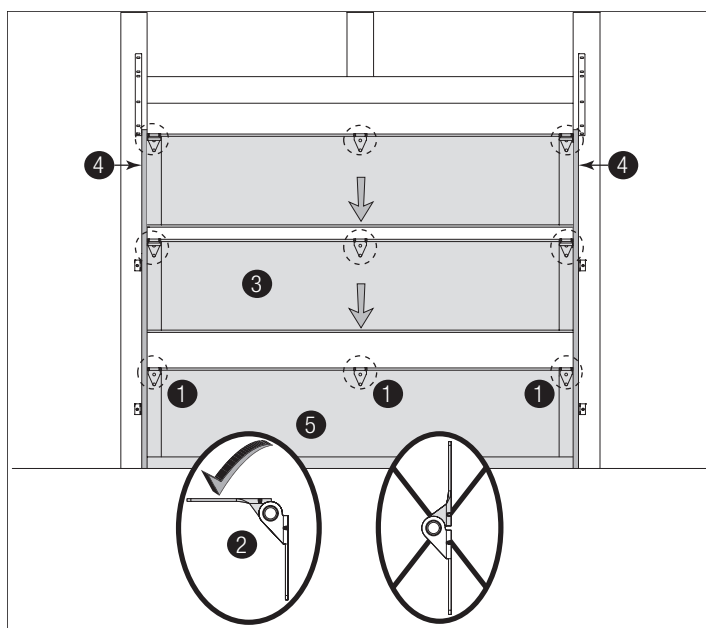

Figure 36, Left Side Shown

For Center Hinge(s):

10c. Starting with a center hinge (6), flip the upper hinge leaf up (7). If needed use it as a template, mark and pre-drill (2) 9/32" diameter holes through the section.

10d. Attach the upper hinge leaf to the section using (2) 1/4" - 20 x 1-7/8" carriage bolts (8) and (2) 1/4" - 20 flange hex nuts (9).

10d. Repeat same process for the other Center Hinges.

For Half Center Hinge(s):

10e. Flip a half center hinge (10) upper hinge leaf up and use it as a template. Mark and pre-drill (2) 1/8" pilot holes, 1" deep into the section with a 1/8" drill bit.

IMPORTANT: Be extremely careful not to drill thru the section. Only drill 1" deep.

10f. Attach the center hinge upper leaf to the section using (2) 1/4" - 14 x 1" lag screws (11).

10g. Repeat same process for other half center hinge(s).

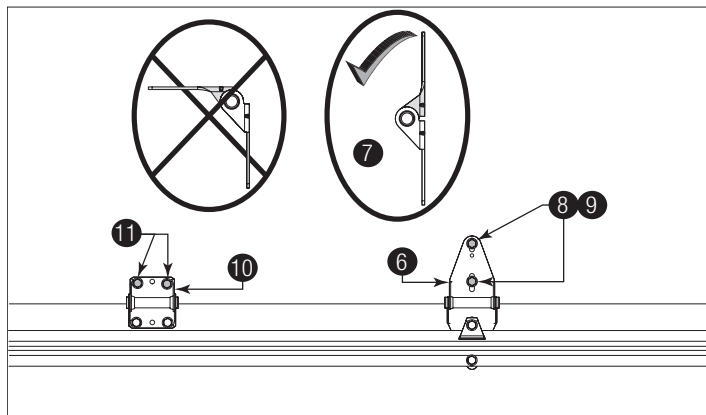

Figure 37, Left Side Shown

For Graduated End Hinges:

10h. Starting with the outer graduated end hinges (12), flip the upper hinge leaf up. If needed use it as a template, mark and pre-drill (2) 9/32" diameter holes through the section.

10i. Attach the upper hinge leaf to the section using (2) 1/4" - 20 x 1-7/8" carriage bolts and (2) 1/4" - 20 flange hex nuts.

10j. Repeat same process for the other side.

If You Have Double Graduated End Hinges:

10k. Flip the inner upper hinge leaf up and use it as a template. Mark and pre-drill

(2) 1/8" pilot holes, 1" deep into the section with a 1/8" drill bit.

IMPORTANT: Be extremely careful not to drill thru the section. Only drill 1" deep.

10l. Attach the inner upper hinge leaf to the section using (2) 1/4" - 14 x 1" lag screws.

10m. Repeat same process for the other side.

10n. Repeat same process for other sections, except top section.

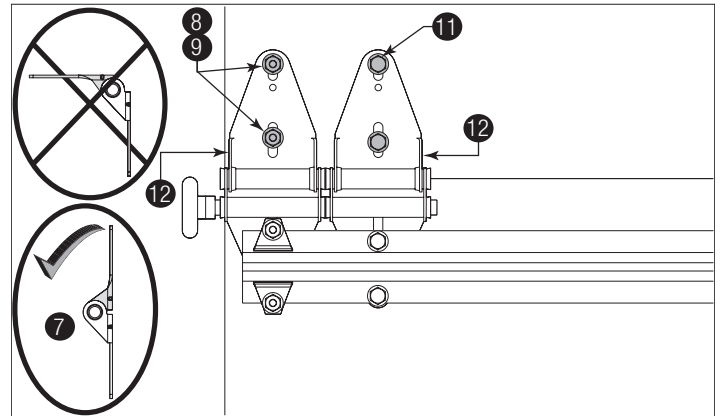

Figure 38, Left Side Shown

1	Graduated End And Center Hinges	7	Hinge Flipped Up Position
2	Hinge Flipped Down Position	8	1/4" - 20 x 1-7/8" Carriage Bolt
3	Second (Intermediate) Section	9	1/4" - 20 Flange Hex Nut
4	Vertical Tracks	10	Half Center Hinge
5	Bottom Section	11	1/4" - 14 x 1" Lag Screw
6	Center Hinge	12	Graduated End Hinge

11 STACKING TOP SECTION

IMPORTANT: The dimension between the flag angles or angle mounts (1) must be:

For 2" Track Applications: Door width plus 3-3/8" (86mm) to 3-1/2" (89 mm) for smooth, safe door operation (2).

For 3" Track Applications: Door width plus 4-7/8" (124mm) to 5" (127 mm) for smooth, safe door operation (3).

See Figure 39 for the following steps.

11a. Place the top section (4) in the opening, on top of the section stacked.

11b. Install a nail (5) to temporarily hold the top section.

11c. Flip up the hinge leaves, hold tight against section, and fasten center hinges first and end hinges last (see Stacking Sections).

11d. For 2" track applications, position flag angle or angle mount between 1-11/16" (43 mm) to 1-3/4" (44 mm) from the edge of the door (6); tighten the bottom lag screw. For 3" track applications, position flag angle or angle mount between 2-3/16" (56 mm) to 2-1/4" (57 mm) from the edge of the door (7); tighten the bottom lag screw.

Flag angles or angle mount must be parallel to the door sections. Repeat for other side.

11e. Complete the vertical track installation.

If You Have Fully Adjustable Track Or Riveted Track: Secure the jamb bracket(s) and tightening the other lag screws. Push the vertical track against the track rollers **8** so that the track rollers are touching the deepest part of the curved side of the track; tighten all the track bolts and nuts. Repeat for other side.

If You Have Angle Mount Track: Complete the vertical track installation by tightening the other lag screws. Push the vertical track against the track rollers **8** so that the track rollers are touching the deepest part of the curved side of the vertical track. Repeat for other side.

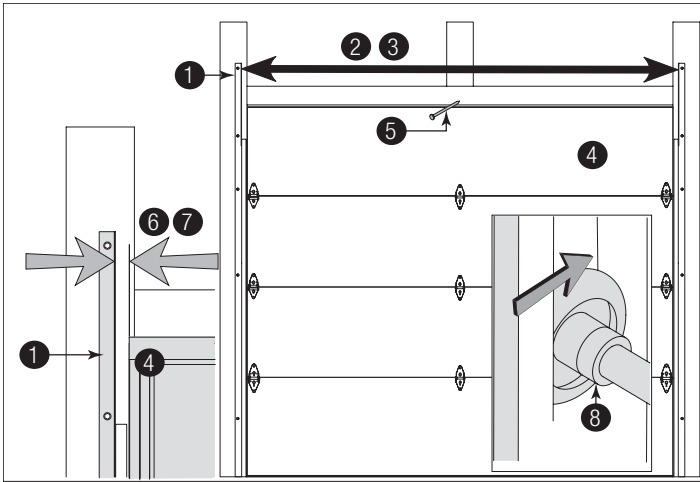

Figure 39

1	Clearance Measurement Between Flag Angle Or Angle Mount	5	Nail
2	2" Track Applications: Door width plus 3-3/8" (86mm) to 3-1/2" (89 mm)	6	For 2" track applications, position flag angle or angle mount between 1-11/16" (43 mm) to 1-3/4" (44 mm)
3	3" Track Applications: Door width plus 4-7/8" (124mm) to 5" (127 mm)	7	For 3" track applications, position flag angle or angle mount between 2-3/16" (56 mm) to 2-1/4" (57 mm)
4	Top Section	8	Vertical Track Against Track Rollers

12 ATTACHING HORIZONTAL TRACKS

NOTE: Depending on your door, you may have Fully Adjustable Flag Angles, Riveted Vertical Track Assemblies or you may have Angle Mount Vertical Track Assemblies. Refer to Package Contents / Breakdown of Parts, to determine which Flag Angles / Vertical Track Assemblies you have.

WARNING

DO NOT RAISE DOOR UNTIL HORIZONTAL TRACKS ARE SECURED AT REAR, AS OUTLINED IN STEP 23, ATTACHING REAR BACK HANGS. THE REAR BACK HANGS OR DOOR COULD FALL FROM OVERHEAD POSITION CAUSING DEATH OR SERIOUS INJURY.

If You Have Fully Adjustable Flag Angles Or Riveted Track Assemblies:

See Figure 40 for the following steps.

12a. Place upper rail of horizontal track **1** over the top track roller of the top section.

12b. Attach lower rail of the horizontal track **2** to the flag angle **3** with two 1/4" - 20 x 9/16" track bolts **4** and two 1/4" - 20 flange hex nuts **5**.

12c. Level **6** the horizontal track assembly and bolt the upper rail of the horizontal track to the encountered slot in the flag angle using one 1/4" - 20 x 9/16" track bolt **7**, one 1/4" - 20 flange hex nut **8** and one 5/16" washer **9**. Repeat same process for other side.

12d. Repeat for right side.

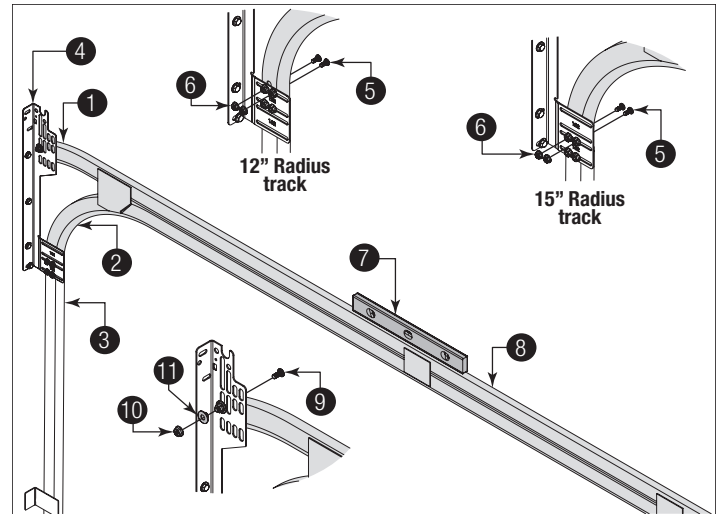

Figure 40, Left Side Shown

1	Upper Rail Of Horizontal Track	6	Level
2	Lower Rail Of Horizontal Track	7	1/4" - 20 x 9/16" Track Bolt
3	Flag Angle	8	1/4" - 20 Flange Hex Nut
4	1/4" - 20 x 9/16" Track Bolts	9	5/16" Washer
5	1/4" - 20 Flange Hex Nuts		

For Angle Mount Vertical Track Assemblies:

See Figure 41 for the following steps.

12a. Place upper rail of horizontal track **1** over the top track roller of the top section.

12b. Attach lower rail of the horizontal track **2** to the angle mount **3** with two 1/4" - 20 x 9/16" track bolts **4** and two 1/4" - 20 flange hex nuts **5**.

12c. Level **6** the horizontal track assembly.

12d. Bolt the upper rail of the horizontal track to the encountered slot in the angle mount using one 1/4" - 20 x 9/16" track bolt **7**, one 1/4" - 20 flange hex nut **8** and one 5/16" washer **9**. Secure the upper rail of the horizontal track to the encountered slots in the angle mount using two 3/8" - 16 x 3/4" truss head bolts **10** and two 3/8" - 16 hex nuts **11**. Repeat same process for other side.

COUNTERBALANCE INSTALLATION INSTRUCTIONS

14 ATTACHING END BEARING BRACKETS

NOTE: Refer to Package Contents or Breakdown Of Parts, to determine which type of end bearing bracket **1** you received.

IMPORTANT: Drill 3/16" pilot holes into the door jamb for the lag screws.

NOTE: End bearing brackets are right and left hand.

See Figure 43 for the following steps.

14a. Align the bottom edge **2** of left end bearing bracket with the top edge of the flag angle **3**.

14b. Maintaining this alignment, also align the right edge of the end bearing bracket with the right edge of the flag angle.

14c. Secure the end bearing bracket to the jamb using three 5/16" x 1-5/8" lag screws **4**.

14d. Repeat same process for the other side.

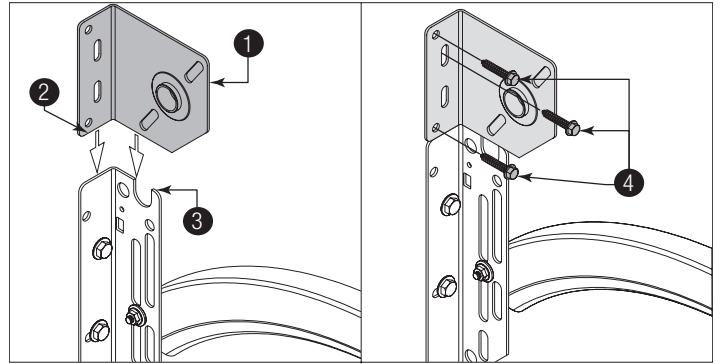

Figure 43, Left Side Shown (For M3. Bracket)

1	End Bearing Bracket	3	Bottom Edge
2	Flag Angle	4	5/16" x 1-5/8" Lag Screws

See Figure 44 for the following steps.

14a. Position the left hand end bearing bracket up against the jamb and on the horizontal track **2**.

14b. Fasten the left hand end bearing bracket to the horizontal track with one 3/8" - 16 x 3/4" truss head bolt **3** and one 3/8" - 16 nut **4**.

14c. Secure the left hand end bearing bracket to the jamb using three 5/16" x 1-5/8" lag screws **5**.

14d. Repeat same process for the other side.

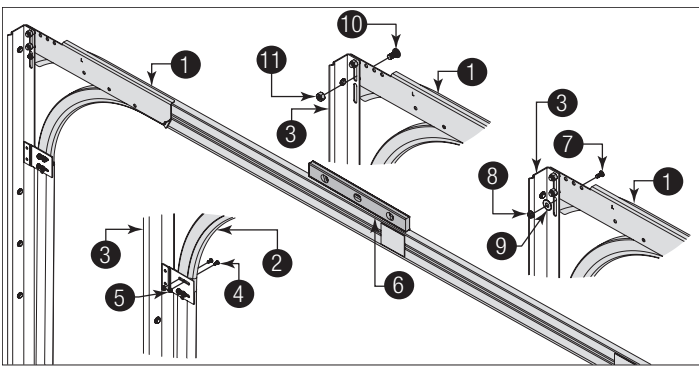

Figure 41, Left Side Shown

1	Upper Rail Of Horizontal Track	7	1/4" - 20 x 9/16" Track Bolt
2	Lower Rail Of Horizontal Track	8	1/4" - 20 Flange Hex Nut
3	Angle Mount	9	5/16" Washer
4	1/4" - 20 x 9/16" Track Bolts	10	3/8" - 16 x 3/4" Truss Head Bolts
5	1/4" - 20 Flange Hex Nuts	11	3/8" - 16 Hex Nuts
6	Level		

12e. When complete, remove the nail that was holding the top section in position.

NOTICE

FAILURE TO REMOVE NAIL BEFORE ATTEMPTING TO RAISE DOOR COULD CAUSE PERMANENT DAMAGE TO TOP SECTION.

13 ADJUSTING TOP FIXTURES

See Figure 42 for the following steps.

13a. Vertically align the top section **1** of the door with the lower sections **2**.

13b. Maintaining the position the top fixture(s) **3**, out against the horizontal track **4**, tighten the 1/4" - 20 flange hex nuts **5** to secure each of the top fixtures

13c. Repeat for the right side.

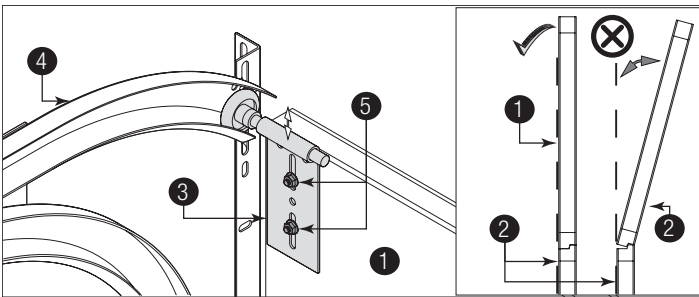

Figure 42, Left Side Shown

1	Door Top Section	4	Horizontal Track
2	Lower Sections	5	1/4" - 20 Flange Hex Nuts
3	Top Fixture		

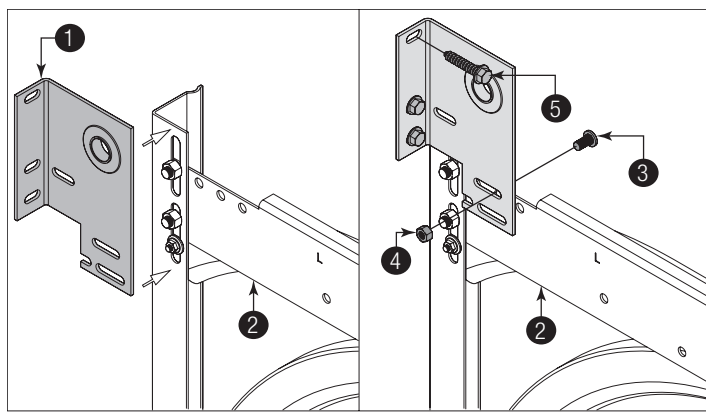

Figure 44, Left Side Shown (For M4. Bracket)

1	End Bearing Bracket	4	3/8" - 16 Hex Nut
2	Horizontal Track	5	5/16" x 1-5/8" Lag Screws
3	3/8" - 16 x 3/4" Truss Head Bolt		

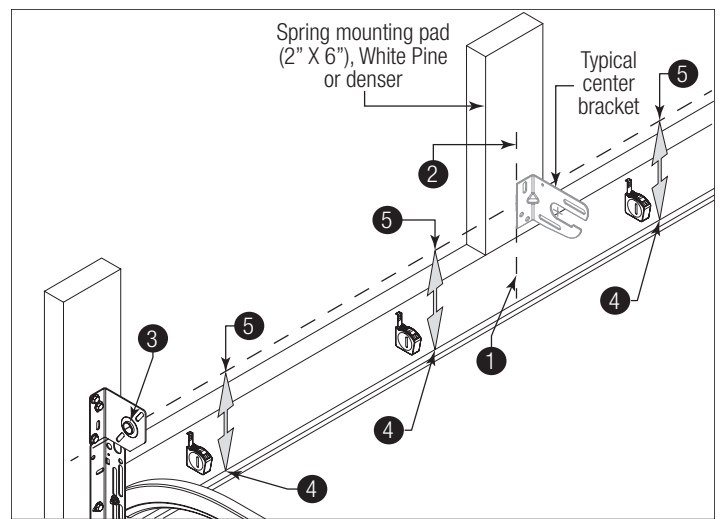

Figure 45, Left Side Shown

1	Center Of The Door	4	Top Of Door
2	Vertical Line	5	Horizontal Line
3	End Bearing Brackets		

See Figure 46 for the following steps.

If your door did not come with a center coupler assembly or Torsion Springs less than 3-3/4" ID:

15e. Mark a vertical pencil line ① on the mounting surface above the door, at the center.

15f. Align the edge of the center bracket ② with the vertical pencil line and the center of the center bracket with the horizontal pencil line ③; this is to ensure the torsion shaft is level between the center and end bearing brackets.

NOTE: On some single spring doors, the spring can be longer than half the opening width. If your spring is longer, then the center bracket must be mounted off center for the spring to fit properly. Measure spring length adding room for spring growth during winding, to determine appropriate center bracket location.

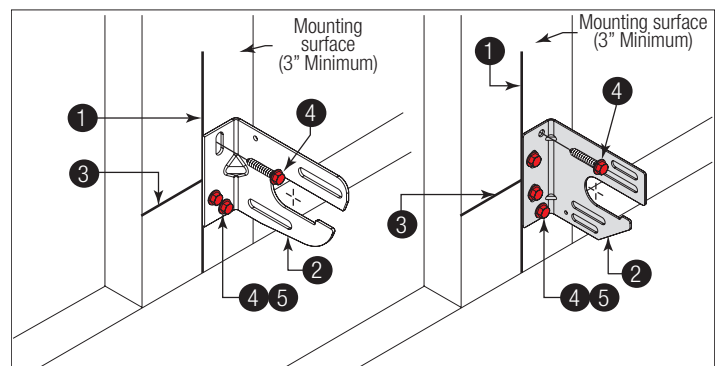

Figure 46

1	Vertical Line	3	Horizontal Line
2	Center Bracket		

See Figure 47 for the following steps.

If your door did come with a center coupler assembly or 3-3/4" ID Torsion Springs:

15e. Mark a vertical pencil line ① on the mounting surface above the door, at the center.

15f. Split the difference up and position the (2) center bearing brackets ② apart from each other.

15 ATTACHING CENTER BRACKET TO WALL

NOTE: Refer to Package Contents / Breakdown of Parts, to determine which Center Bracket(s) came with your door.



MAKE SURE THE CENTER BRACKET IS SECURELY INSTALLED ONTO THE HEADER. FAILURE TO DO SO, COULD RESULT IN DEATH OR SERIOUS INJURY.

IMPORTANT: Drill 3/16" pilot holes into header for the lag screws.

NOTE: Refer to Package Contents / Breakdown of Parts, to determine if your door came with a coupler assembly. If your door came with a coupler assembly, the mounting surface needs to be a minimum of 17" wide. The two center bearing brackets will need to be spaced 12" to 14" apart at the center of the door, as shown.

NOTE: If your door came with (4) springs, each of the outer springs mounting surface will need to be a minimum of 3" wide.

NOTE: If needed, measure the diameter of your springs. If you have a one piece shaft with 3-3/4" diameter springs, they do not share center brackets and do not have a coupler assembly.

See Figure 45 for the following steps.

15a. First, locate the center of the door ①.

15b. Mark a vertical pencil line ② on the mounting surface above the door, at the center.

15c. Measure from the center of the bearing, in one of the end bearing brackets ③, downwards, to the top the door ④.

15d. Using that measurement, measure that distance upwards from the top of the door to the mounting surface and mark a horizontal pencil line ⑤ which intersects the vertical pencil line.

15g. Mark two vertical pencil lines, one for each center bearing bracket onto the mounting surface above the door.

NOTE: If your door came with a center coupler assembly or if it utilizes 3-3/4" springs, the springs will not share a center bracket.

NOTE: If your door has (4) springs, split the distance between the center of the door and the end bracket on each side to locate the intermediate center brackets.

15h. Attach the center bracket(s) to the mounting surface, using 5/16" RED HEAD lag screws (3), as shown.

IMPORTANT: Use a 5/16" x 2-1/2" RED HEAD lag screw (4) instead of the 5/16" x 1-5/8" RED HEAD lag screw if mounting surface is covered by drywall. The lag screw must be attached through the bottom hole (5) of the center bracket(s). If mounting surface is a 2" x 6" board installed on top of masonry, drill a clearance hole in masonry for the 5/16" x 2-1/2" RED HEAD lag screws.

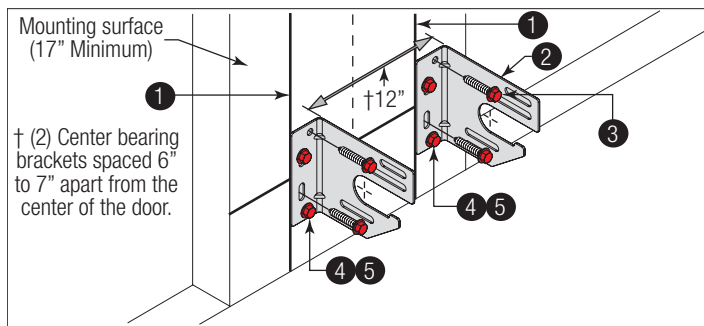

Figure 47

1	Vertical Line	4	5/16" x 2-1/2" RED HEAD lag screw
2	Center Bearing Brackets	5	Bottom Hole
3	5/16" RED HEAD Lag Screws		

16 TORSION SPRING ASSEMBLY

NOTE: Refer to the Package Contents and or Breakdown of Parts to determine if your door came with a coupler assembly.

IMPORTANT: Right and left hand is always determined from inside the building looking out.

IMPORTANT: Identify the torsion springs provided as either right wound (red winding cone) (1), which goes on the RIGHT HAND SIDE or left wound (black winding cone) (2), which goes on the LEFT HAND SIDE.

IMPORTANT: On single spring applications, only a left wound (black winding cone), is required.

NOTE: The set screws used on all winding cones and cable drums are colored red. DO NOT identify right and left hand by the set screw color.

See Figure 48 and Figure 49 for the following steps.

If you don't have a Coupler Assembly:

16a. Facing the inside of the door, lay the torsion shaft / torsion keyed shaft (3) on the floor. Lay the torsion spring with the red winding cone at the right end of the torsion shaft. Lay the torsion spring with the black winding cone at the left end of the torsion shaft. Slide the center bracket bearing (4) onto the torsion shaft followed by the torsion springs and set collars (if applicable) (5).

IMPORTANT: The center bracket bearing, torsion springs, and set collars (if applicable) must be positioned, as shown.

16b. With assistance, pick up the torsion spring assembly and slide one end of the torsion shaft / torsion keyed shaft through one end bearing bracket (6).

16c. Lay the middle of the torsion shaft / torsion keyed shaft into the center bracket (7).

16d. Slide the other end of the torsion shaft / torsion keyed shaft into the other end bearing bracket (8).

16e. Position the torsion shaft / torsion keyed shaft so that equal amounts (9) of the shaft extend from each end bearing bracket.

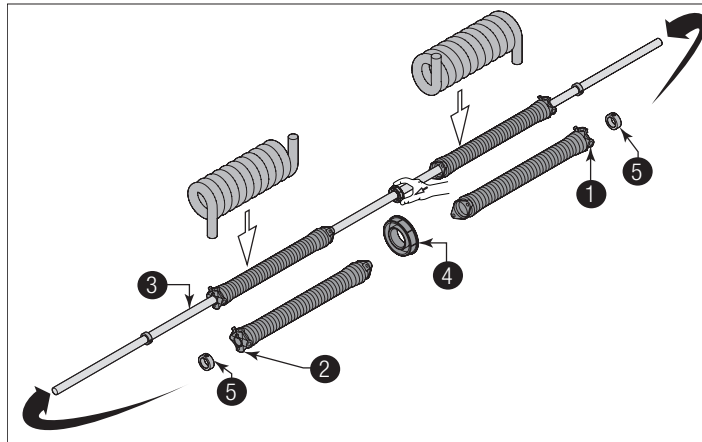

Figure 48

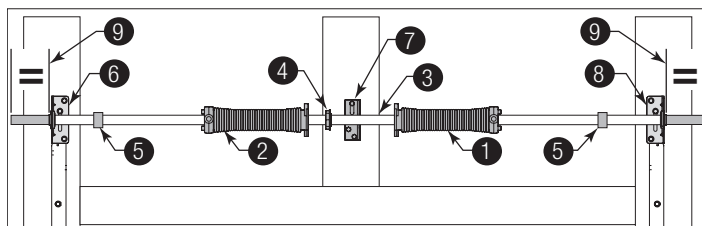

Figure 49

1	Red Winding Cone	6	End Bearing Bracket
2	Black Winding Cone	7	Center Bracket
3	Torsion Shaft / Torsion Keyed Shaft	8	End Bearing Bracket
4	Center Bracket Bearing	9	Equal Amounts
5	Set Collar		

See Figure 50 through Figure 54 for the following steps.

If you have a Coupler Assembly:

16a. Disassemble the coupler assembly (10) by removing the (3) 3/8" - 16 x 1-3/4" hex head screws (11), (6) 3/8" washers (12), (3) 3/8" lock washers (13) and the (3) 3/8" - 16 nylon hex lock nuts (14) from the coupler halves (15).

16b. Loosen the set screws (16).

16c. Set the components aside.

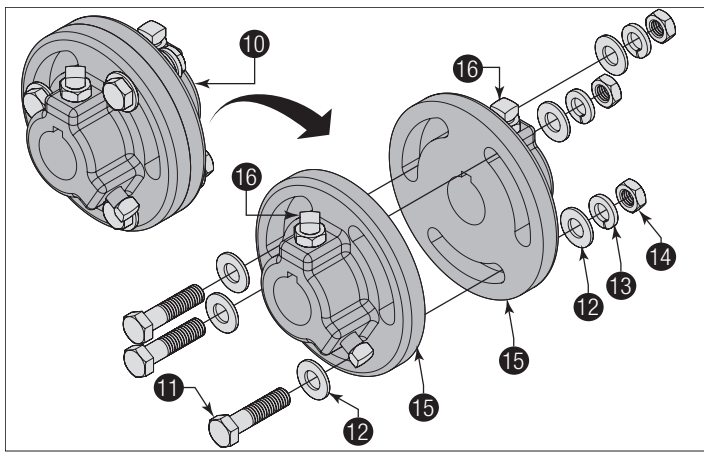

Figure 50

10	Coupler Assembly	14	3/8" - 16 Hex Nuts
11	3/8" - 16 x 1-1/2" Hex Head Screws	15	Coupler Halves
12	3/8" Washers	16	Set Screws
13	3/8" Lock Washers		

16d. Facing the inside of the door, lay the (2) torsion keyed shafts (3) on the floor. One torsion keyed shaft on the left hand side and the other torsion keyed shaft on the right hand side. Starting on the left hand side, lay one of the coupler halves, the center bracket bearing (4), torsion spring with the black winding cone (2) and one set collar (5) at the left end of the torsion keyed shaft. Next on the right hand side, lay the other coupler half, center bearing, the torsion spring with the red winding cone (1) and one set collar at the right end of the torsion keyed shaft. Slide the coupler halves (15), center bearings onto the torsion keyed shafts followed by the torsion springs and the set collars, as shown.

IMPORTANT: The coupler halves, center bracket bearings, torsion springs, cable drums must be positioned, as shown.

16e. Slide the flat edge of the coupler half flush with the side edge of the torsion keyed shaft. Insert (1) key (18) into the slot of both the coupler half and the slot in the torsion keyed shaft. Tighten the (2) set screws (16) and the locking nut (17) to secure the coupler half to the torsion keyed shaft, as shown.

NOTE: Tighten the set screws to 14-15 ft-lbs (Once set screws contact the shaft, tighten screws an additional 1/2 turn).

16f. Repeat the same process for the other coupler half.

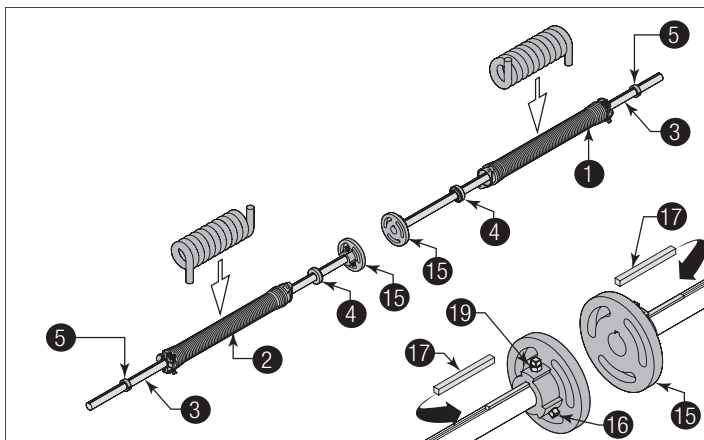

Figure 51

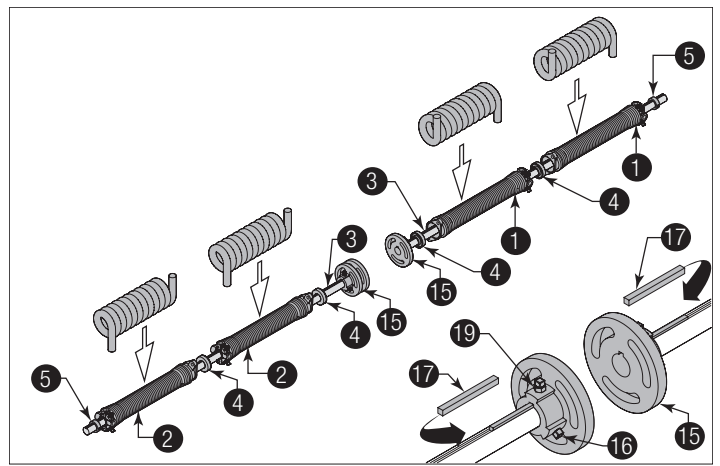

Figure 52

1	Red Winding Cone	15	Coupler Halves
2	Black Winding Cone	17	Key
3	Torsion Keyed Shafts	16	Set Screws
4	Center Bracket Bearing	19	Locking Nut
5	Set Collar		

16g. With assistance and starting on the left hand side of door, pick up the left hand torsion spring assembly (20) and slide one end of the torsion keyed shaft through the end bearing bracket (6).

16h. Lay the other side of the torsion keyed shaft into the center bracket (7).

16i. Repeat the same process for the right hand torsion spring assembly (21).

16j. Position both torsion keyed shafts so that equal amounts (9) of the shafts extend from each end bearing brackets.

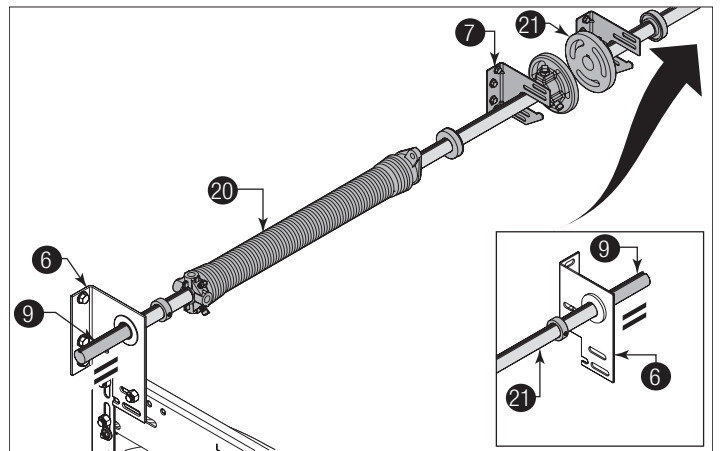

Figure 53, Left Side Shown

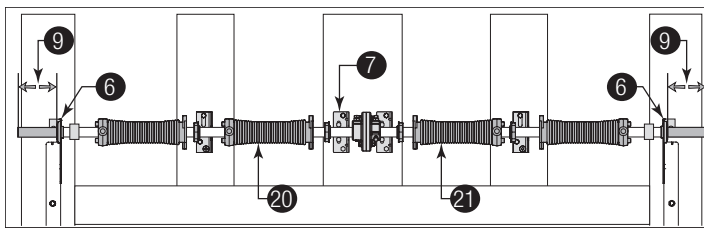

Figure 54, Left Side Shown

20	Left Hand Torsion Spring Assembly	21	Right Hand Torsion Spring Assembly
6	End Bearing Bracket	9	Equal Amounts
7	Center Bracket		

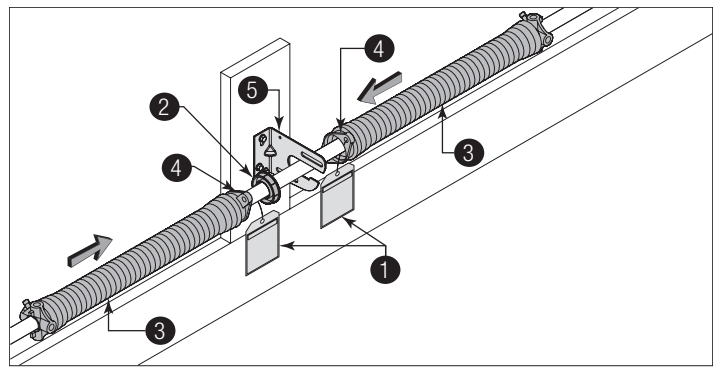

Figure 55

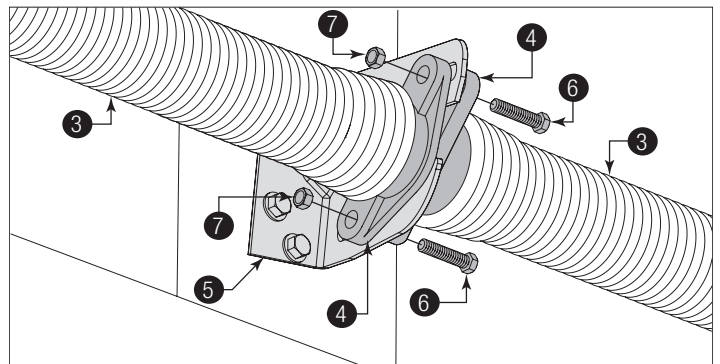

Figure 56

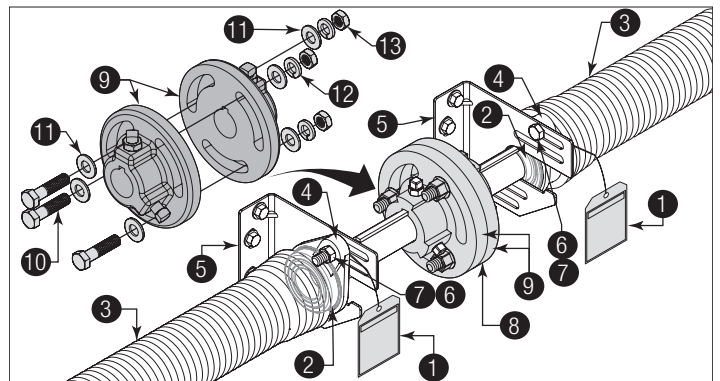

Figure 57

1	Spring Warning Tag(s)	8	Coupler Assembly
2	Center Bracket Bearing	9	Coupler Halves
3	Spring	10	3/8" - 16 x 1-1/2" Hex Head Screws
4	Stationary Spring Cone(s)	11	3/8" Washers
5	Center Bracket	12	3/8" Lock Washers
6	3/8" - 16 x 1-1/2" Hex Head Bolts	13	3/8" - 16 Hex Nuts
7	3/8" - 16 Nuts		

17 ATTACHING SPRINGS TO CENTER BRACKET

NOTE: Refer to Package Contents / Breakdown of Parts, to determine which Center Bracket(s) came with your door.

NOTE: Refer to Package Contents / Breakdown of Parts, to determine if your door came with a coupler assembly.

IMPORTANT: The spring warning tag(s) 1 supplied must be securely attached to the stationary spring cone(s) in plain view. Should a replacement spring warning tag be required, contact Wayne Dalton for free replacements.

NOTE: Measure the diameter of your springs. If your spring diameter is 3-3/4", the springs do not share center brackets. If your spring diameter is either 2" or 2-5/8", then two springs will share the same center bracket, unless a coupler assembly is provided.

See Figure 55 through Figure 57 for the following steps.

If You Don't Have A Coupler Assembly:

- 17a. Slide center bracket bearing 2 into the spring 3.
- 17b. Align the stationary spring cone (s) 4 with the holes in the center bracket 5.
- 17c. Secure the torsion spring(s) to the center bracket bearing assembly with (2) 3/8" - 16 x 1-1/2" hex head bolts 6 and (2) 3/8" - 16 nuts 7.

IMPORTANT: Never use more than one bearing when attaching two springs to one center bracket.

If You Have A Coupler Assembly:

- 17a. Slide center bracket bushing 2 into the spring 3.
- 17b. Align the stationary spring cone 4 with the holes in the center bracket 5.
- 17c. Secure the torsion spring to the center bracket with (2) 3/8" - 16 x 1-1/2" hex head bolts 6 and (2) 3/8" - 16 nuts 7.
- 17d. Repeat the same process for the other center bearing bracket.
- 17e. At the middle of the two center bearing brackets, re-assemble the coupler assembly 8 by loosely fastening the coupler halves 9 together using the (3) 3/8" - 16 x 1-1/2" hex head screws 10, (6) 3/8" washers 11, (3) 3/8" lock washers 12, and the (3) 3/8" - 16 nylon hex lock nuts 13, previously removed.

NOTE: Ensure both torsion keyed shafts have equal amounts of the shafts extending from each end bearing bracket.

18 ATTACHING COUNTERBALANCE LIFT CABLES

See Figure 58 through Figure 60 for the following steps.

18a. Starting on the left hand side, slide the red cable drum 1 onto the torsion shaft / torsion keyed shaft(s) 2.

18b. Hook 3 the counterbalance lift cable 4 into the left hand cable drum and thread the counterbalance lift cable up and around the front side of the cable drum. Slide the left hand cable drum up against the left hand end bearing bracket 5. Counterbalance lift cable should terminate at the 3 o'clock position 6 - 6 o'clock position 7.

IMPORTANT: Verify that there are no obstructions in the travel path of the door sections or counterbalance lift cables.

NOTE: Always assemble the left hand cable and cable drum first to help maintain equal cable tension on both sides of the door.

NOTICE

FAILURE TO REMOVE ALL SLACK OUT OF THE COUNTERBALANCE LIFT CABLES, WILL CAUSE DOOR OPERATIONAL PROBLEMS.

WARNING

TO AVOID RISK OF COUNTERBALANCE FAILURE CAUSING DEATH OR SERIOUS INJURY, THE COUNTERBALANCE LIFT CABLE MUST TERMINATE BETWEEN THE 3 O'CLOCK AND 6 O'CLOCK POSITION. IF THE COUNTERBALANCE CABLE DOES NOT TERMINATE IN THE CORRECT POSITION, THE CABLE LENGTH MUST BE CORRECTED BY A TRAINED DOOR SYSTEMS TECHNICIAN BEFORE CONTINUING INSTALLATION.

NOTE: If you have torsion keyed shaft(s) 5, insert (1) key 8 into the slot of both the cable drum and the slot in the torsion keyed shaft, as shown.

18c. Tighten the set screws 9 in the drum to 14-15 ft-lbs of torque (once set screws contact the torsion shaft, tighten screws an additional 1/2 turn for solid shaft and one full turn for tubular shaft).

18d. Rotate the left hand drum and torsion shaft until counterbalance lift cable is taut. Attach locking pliers 10 to the torsion shaft and brace locking pliers up against jamb 11 to keep counterbalance lift cable taut.

18e. Repeat for right hand side using the right hand side the black cable drum.

IMPORTANT: Verify that there are no obstructions in the travel path of the door sections or counterbalance lift cables.

IMPORTANT: Inspect each counterbalance lift cable making sure it is seated properly onto the cable drum and that both counterbalance lift cables have equal tension.

18f. Check Counterbalance Lift Cables for Equal Tension:

1. Attach locking pliers to track above top roller.
2. Grasp cable at approximate mid-door height location.
3. Draw cable toward you about 1/2" to 1" and release, noting the response of the cable.
4. Repeat above steps for other cable.
5. Adjust cable tension as needed until right and left cables both respond the same.

18g. Once the counterbalance cables are set and if applicable tighten the coupler assembly together by tightening the (3) 3/8" - 16 nylon hex lock nuts to secure the coupler halves together.

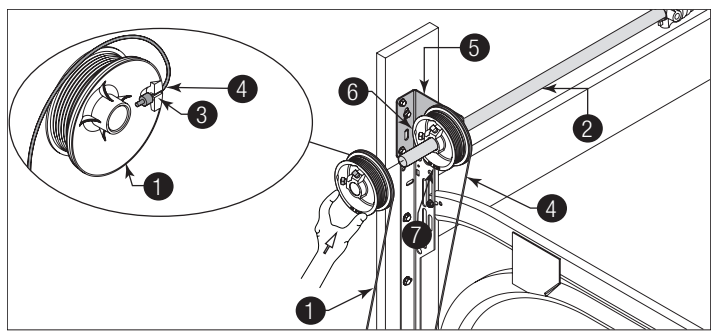

Figure 58, Left Side Shown

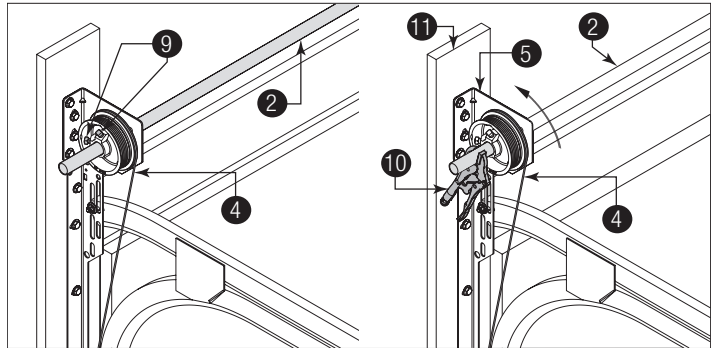

Figure 59, Left Side Shown

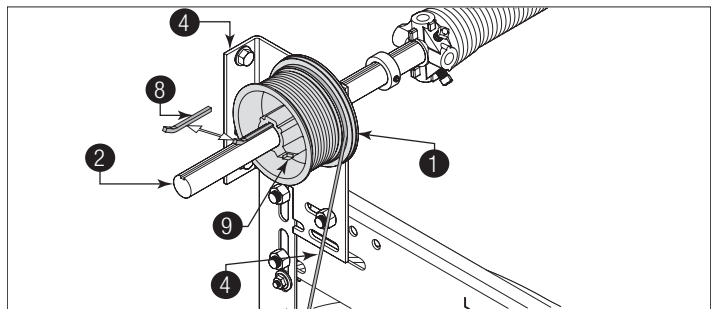

Figure 60, Left Side Shown

1	Cable Drum	7	6 O'Clock Position
2	Torsion Shaft / Torsion Keyed Shaft	8	Key
3	Hook	9	Set Screws
4	Counterbalance Lift Cable	10	Locking Pliers
5	End Bearing Bracket	11	Jamb
6	3 O'Clock Position		

19 SET COLLARS

NOTE: If your door did not come with set collars, then skip this step.

IMPORTANT: Prior to tightening the set screws in the set collars, avoid placing the set screws in the keyways of torsion keyed shaft(s).

See Figure 61 for the following steps.

19a. Slide each of the set collars 1 up against the inside surface of the end bearing brackets 2, with the set screw facing directly away from the header 3.

19b. Tighten the set screw ④ in each of the set collars to the torsion shaft ⑤ to 14-15 ft. lbs. of torque (once set screw contacts the shaft, tighten set screw one full turn).

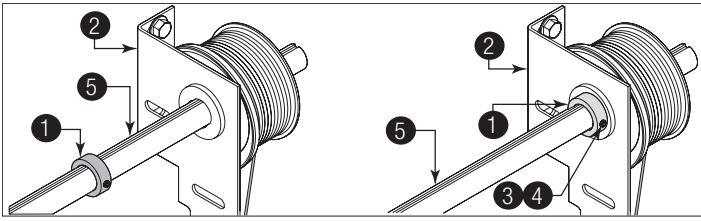

Figure 61

1	Set Collars	4	Set Screw
2	End Bearing Brackets	5	Torsion Shaft
3	Set Screw Facing Directly Away From The Header		

20 CHALKING TORSION SPRING(S)

NOTE: If your springs have stenciling, then skip this step.

See Figure 62 for the following steps.

20a. Draw a chalk line horizontally along the center of the torsion spring coils ①. As the torsion spring is wound, the chalk line will create a spiral ②. This spiral can be used to count and determine the number of turns that are applied on the torsion spring ③.

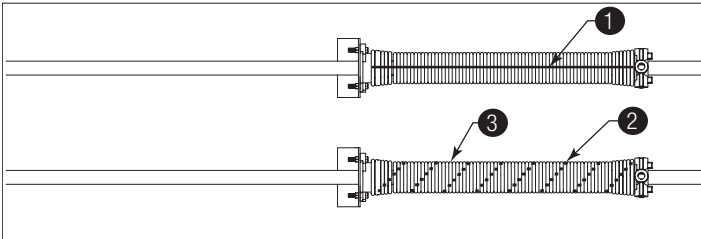

Figure 62

1	Draw horizontal chalk line prior to winding	3	Spirals created after winding
2	Spiral		

21 SECURING DOOR FOR SPRING WINDING

See Figure 63 for the following steps.

21a. With the door in the fully closed position, place locking pliers ④ onto both vertical tracks ① and ② just above the third track roller ③. This is to prevent the garage door from rising while winding spring(s). Ensure that:

21b. **Check the following before attempting to wind torsion spring(s):**

Counterbalance lift cables are secured at bottom corner brackets, See Figure 12 and Figure 13.

- Counterbalance lift cables are unobstructed in their route to cable drums.
- Counterbalance lift cables are correctly installed and wound onto cable lift drums.
- Counterbalance lift cables are taut and have equal tension on both sides.
- Cable lift drums are against end bearing brackets and set screws are tight.
- Torsion spring or springs are installed correctly.

- Review the label attached to the spring warning tag, to determine number of spring turns required.

! WARNING

FAILURE TO PLACE LOCKING PLIERS ONTO VERTICAL TRACKS CAN ALLOW DOOR TO RAISE DURING SPRING WINDING AND CAUSE SEVERE OR FATAL INJURY.

! CAUTION

TO AVOID POSSIBLE DAMAGE TO YOUR DOOR, THE DOOR MUST BE CLOSED AND LOCKED WHEN WINDING OR MAKING ANY ADJUSTMENTS TO THE SPRING(S).

Winding Bars (Steel Rods)	Size Of Winding Bar (Inches)	Spring Inner Diameter Used On
—————	1/2" dia. x 18"	2" and 2-5/8"
	5/8" dia. x 24"	3-3/4"

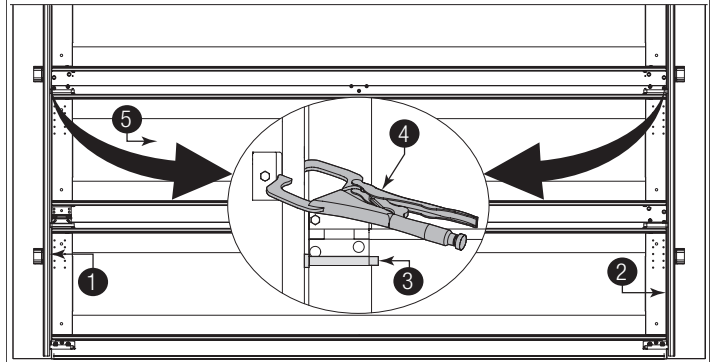

Figure 63

1	Left Side Vertical Track	5	Bottom Section
2	Right Side Vertical Track	6	Second Section
3	Track Roller	7	Intermediate Section
4	Locking Pliers		

22 WINDING SPRING(S)

! DANGER

WINDING SPRING IS AN EXTREMELY DANGEROUS PROCEDURE AND SHOULD BE PERFORMED ONLY BY A TRAINED DOOR SYSTEM TECHNICIAN USING PROPER TOOLS AND INSTRUCTIONS.

! WARNING

USE ONLY SPECIFIED WINDING BARS, AS STATED IN STEP SECURING DOOR FOR SPRING WINDING. DO NOT SUBSTITUTE WITH SCREWDRIVERS, PIPE, ETC. OTHER TOOLS MAY FAIL OR RELEASE FROM THE SPRING CONE AND CAUSE SEVERE OR FATAL INJURY.

! DANGER

PRIOR TO WINDING THE SPRING, ENSURE YOU'RE WINDING IN THE PROPER DIRECTION AS SHOWN IN FIGURE 64. OTHERWISE THE SPRING FITTING MAY RELEASE FROM SPRING AND RESULT IN SEVERE OR FATAL INJURY.

22a. Position a ladder slightly to the side of the spring so that the winding cone is easily accessible, and so your body is not directly in line with the winding bars ①.

22b. Check the label attached to the spring warning tag ② for the required number of complete turns to balance your door.

How to Wind Torsion Springs:

1. Insert one winding rod snugly into winding cone ③, to full socket depth.
2. Maintaining a tight grip on the winding rod rotate it slowly in the proper direction ④, as shown below.
3. If there is any slippage of the winding rod in the winding cone socket, reverse the direction of winding and return the cone to its original position. Remove the winding rod from the winding cone socket. Reseat the winding rod in the socket. Start over at Step #1.
4. When the winding rod is vertical above the winding cone, insert another winding rod into one of the other sockets, being careful to seat it snugly and at full socket depth.
5. Hold the spring with the second winding bar, and remove the first.
6. Repeat Steps #2 through #5 until the complete turns have been applied.

IMPORTANT: Check the warning tag(s) attached to the spring(s) for the required number of complete turns, to balance your door.

IMPORTANT: After winding the spring(s), tighten the set screws ⑤ in the winding cone to 14-15 ft-lbs of torque (once set screws contact the torsion shaft ⑥, tighten screws an additional 1/2 turn for solid shaft and one full turn for tubular shaft).

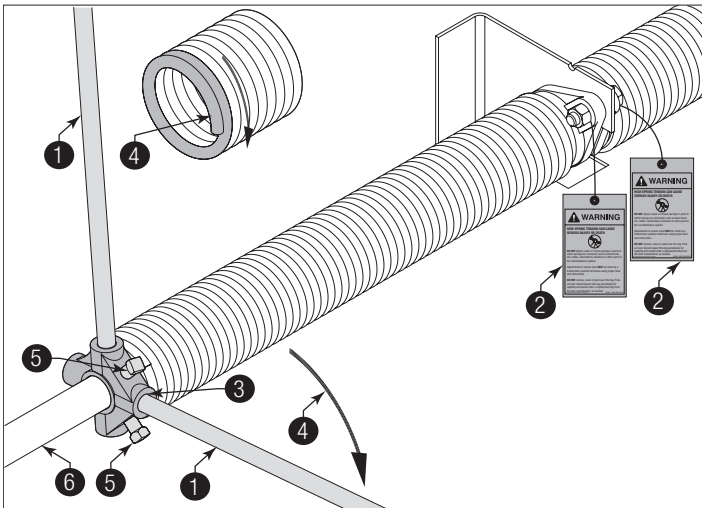

Figure 64

1	Approved Winding Rods	4	Proper Direction
2	Spring Warning Tag	5	Set Screws
3	Winding Cone	6	Torsion Shaft

23 ATTACHING REAR BACK HANGS (NOT INCLUDED)

! WARNING

IN THE EVENT THE SPRING(S) WERE OVER-WOUND, HOLD THE DOOR DOWN FIRMLY AND CAUTIOUSLY REMOVE LOCKING PLIERS FROM VERTICAL TRACKS TO PREVENT IT FROM RISING UNEXPECTEDLY.

See Figures 65, 66, and 67 for the following steps.

23a. Raise the door until the top section and half of the next section are in the horizontal track radius. Do not raise door any further since rear of horizontal tracks are not yet supported.

! WARNING

RAISING THE DOOR FURTHER INTO THE LOOSE HORIZONTAL TRACKS CAN RESULT IN DOOR FALLING CAUSING DEATH OR SERIOUS INJURY.

IMPORTANT: If an opener is installed, position horizontal tracks one hole above level when securing them to the rear back hangs.

23b. Using the chart below, select the appropriate perforated angle. Fabricate and install rear back hangs, as shown.

Perforated Angle Gauge Weight Limitations:	
Perforated Angle Gauge	Door Balance Weight
2" x 2" x 12 Gauge	800 lbs. to 1600 lbs.
1-1/4" x 1-1/4" x 13 Gauge	305 lb. to 610 lb.
1-1/4" x 1-1/4" x 15 Gauge	220 lb. to 440 lb.
1-1/4" x 1-1/4" x 16 Gauge	175 lb. to 350 lb.

! WARNING

KEEP HORIZONTAL TRACKS PARALLEL AND WITHIN 3/4" TO 7/8" (19 MM - 22 MM) MAXIMUM OF DOOR EDGE. OTHERWISE THE TRACK ROLLERS CAN COME OUT AND DOOR WILL FALL, RESULTING IN DEATH OR SERIOUS INJURY.

! WARNING

MAKE SURE BACK HANGS ARE BRACED SUFFICIENTLY TO RESIST ANY MOTION DURING SPRING APPLICATION AND DOOR TRAVEL. IF BACK HANGS PIVOT OR DEFLECT, ADD REINFORCEMENT UNTIL THEY REMAIN FIRM AND STATIONARY. ANY BACK HANG THAT HAS BEEN BENT MUST BE REPLACED. FAILURE TO SECURELY BRACE THE HORIZONTAL TRACK CAN RESULT IN DOOR FALLING CAUSING DEATH OR SERIOUS INJURY.

NOTICE

DO NOT SUPPORT THE WEIGHT OF THE DOOR ON ANY PART OF THE REAR BACK HANGS THAT IS 4" (102 MM) OR MORE BEYOND A SOUND FRAMING MEMBER.

NOTICE

IF REAR BACK HANGS ARE TO BE INSTALLED OVER DRYWALL, USE TWO 5/16" X 2" HEX-HEAD LAG SCREWS AND MAKE SURE LAG SCREWS ENGAGE INTO SOLID STRUCTURAL LUMBER.

! DANGER

FAILURE TO ASSEMBLE AND ATTACH REAR BACK HANGS PROPERLY ACCORDING TO THE ABOVE INSTRUCTIONS MAY RESULT IN DOOR FALLING WHEN RAISED, CAUSING DEATH OR SERIOUS INJURY.

NOTICE

PERFORATED ANGLE MUST BE ATTACHED TO SOUND FRAMING MEMBERS AND NAILS SHOULD NOT BE USED.

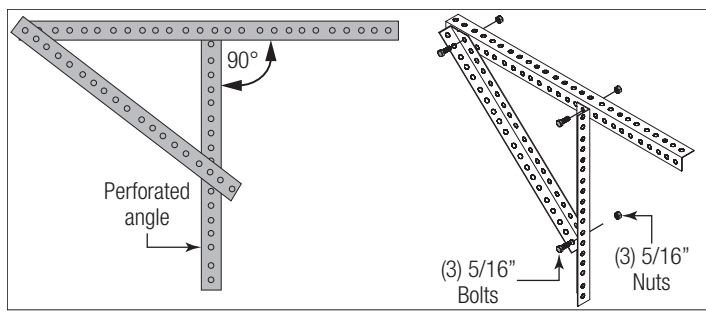

Figure 65

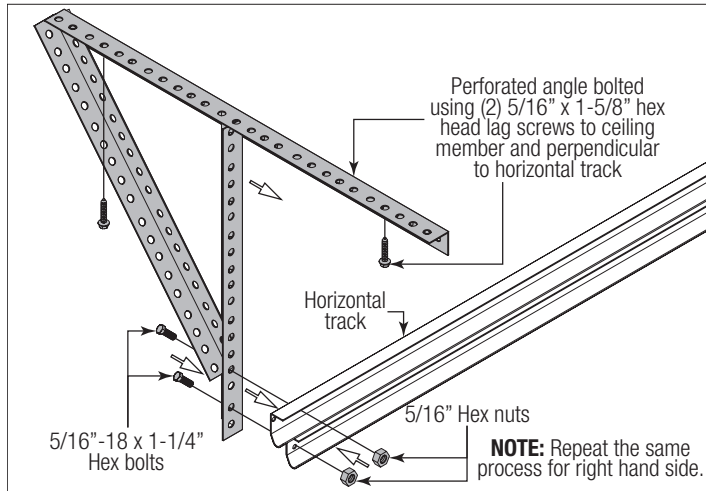

Figure 66

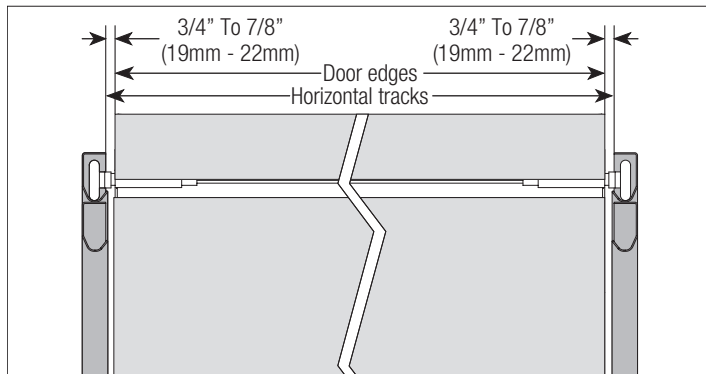

Figure 67

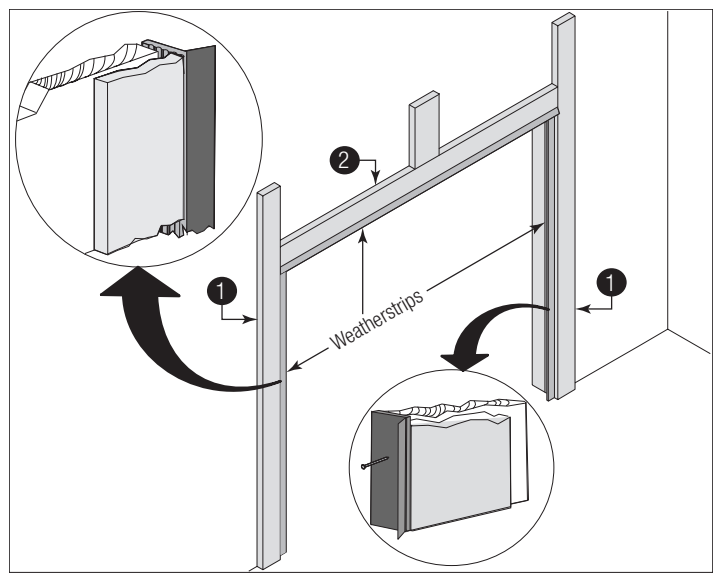

Figure 68, Weatherstrips

1	Door Jambs	2	Header
---	------------	---	--------

25 BALANCING DOOR

CAUTION

WINDOWS MAY CAUSE THE TOP SECTION TO BE SIGNIFICANTLY HEAVIER THAN THE REMAINING SECTIONS. TO PREVENT ANY SUDDEN DOOR ACCELERATION BETWEEN THE TOP AND BOTTOM, MOTOR OPERATE ALL DOORS WITH WINDOWS.

DANGER

EXTREME CAUTION SHOULD BE USED WHEN MAKING ADJUSTMENTS TO THE SPRINGS AS FAILURE TO FOLLOW THE INSTRUCTIONS OR USE APPROVED WINDING BARS CAN LEAD TO DEATH OR SERIOUS INJURY TO PERSONS OR PROPERTY. BEFORE ATTEMPTING TO MAKE ADJUSTMENTS TO THE SPRING, MAKE SURE YOU HAVE READ AND UNDERSTAND THE INSTRUCTIONS. IF YOU ARE UNCLEAR ON ANY ASPECT OF THE INSTALLATION PROCEDURES, YOU SHOULD CONSULT A TRAINED DOOR SYSTEMS TECHNICIAN.

See Figure 69 for the following steps.

25a. Remove locking pliers. Lift door and check its balance. Adjustments to the required number of spring turns stated may be necessary. If door rises off floor more than 2 ft. under spring tension alone, reduce spring tension. If the door is hard to rise or drifts down on its own, add spring tension. A poorly balanced door can cause garage door operator problems.

25b. To adjust spring tension, fully close door. Apply locking pliers to track above third track roller. Place locking pliers on torsion shaft, as shown in Step Attaching Counterbalance Lift Cables. Insert a winding rod ① into the winding cone. Push downward on the winding rod slightly while carefully loosening the set screws ② in the winding cone ③.

WARNING

BE PREPARED TO SUPPORT THE FULL FORCE OF THE TORSION SPRING ONCE THE SET SCREWS ARE LOOSE. IF NOT PREPARED, THEN THE WINDING BAR CAN MOVE SUDDENLY AND COME OUT OF THE WINDING CONE AND CAUSE SEVERE OR FATAL INJURY.

Carefully adjust spring tension 1/4 turn. Retighten both set screws to 14-15 ft. lbs. of torque in the winding cone and repeat for the other side. Recheck door balance and re-adjust spring tension if needed.

24 ATTACHING WEATHERSTRIPS (NOT INCLUDED)

NOTICE

WHEN PERMANENTLY ATTACHING THE WEATHERSTRIPS TO THE JAMBS, AVOID PUSHING THE WEATHER-STRIPS TOO TIGHTLY AGAINST THE FACE OF DOOR.

See Figure 68 for the following steps.

24a. Permanently attach the nails to the weatherstrips on both door jambs ① and the header ②. The weatherstrips were temporarily attached in Preparing the Opening, in the pre-installation section of this manual.

NOTE: For clarity, door isn't shown.

IMPORTANT: Do not adjust more than 1 turn from the recommended number of turns.

If the door still does not operate easily, lower the door into the closed position, unwind spring(s) completely, and recheck the following items:

25c. Is the door level?

25d. Are the torsion shaft and flag angles / angle mount level and plumb?

25e. Does the distance between the flag angles / angle mount equal door width plus 3-3/8" to 3-1/2"?

25f. Do the counterbalance lift cables have equal tension? Adjust if necessary.

25g. Rewind the spring(s).

25h. Make sure door is not rubbing on jambs.

IMPORTANT: If door still does not balance properly, then contact a trained door system technician.

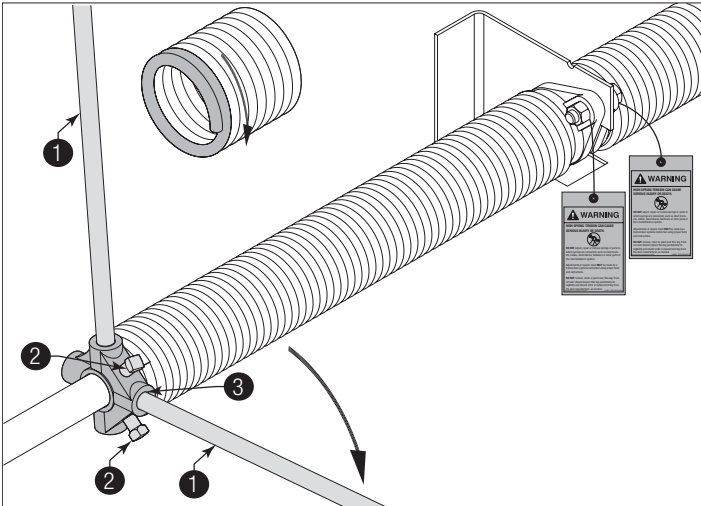

Figure 69

1	Winding Rod	3	Winding Cone
2	Set Screws		

26 LABEL PLACEMENT

IMPORTANT: Using the illustration, attach the appropriate labels to the appropriate location on the section, as shown in Figure 70.

NOTE: The Spring Warning tag(s) are factory attached (one per spring).

NOTE: Because of different configurations, some labels may require minor relocations.

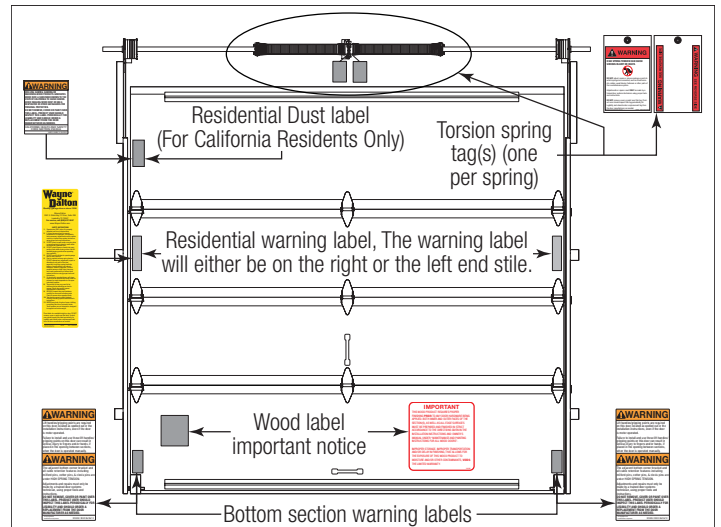

Figure 70, Weatherstrips

OPTIONAL INSTALLATION

Door Arm Hookup

At the center of the top section, measure horizontally from the top of center hinge to the bottom of strut. Using that dimension, measure and cut (2) pieces of perforated angles. Assemble the (2) pieces together using (2) 3/8" bolts and nuts (supplied by others). Now, secure to the top section using carriage bolts and nuts (supplied by others), thru bolt both the perforated angles to the top section, as shown.

Align the door arm with hole with one of the holes in the perforated angles. Secure the door arm to the perforated angle using (1) 5/16" - 18 x 1" hex head bolt and (1) 5/16" - 18 lock nut (supplied by others), as shown.

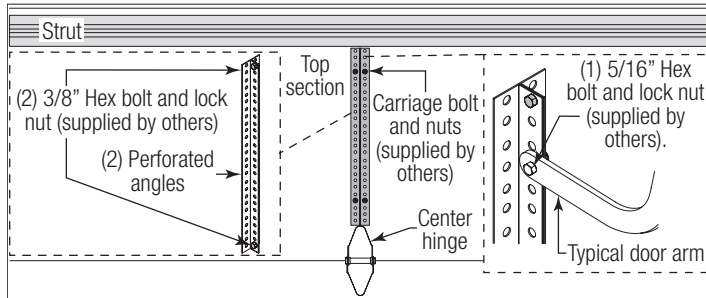

Lift Handles

NOTE: Lift handles must be lined up vertically.

BOTTOM SECTION: Locate the exterior center stile or center most stile on the bottom section.

NOTE: For flush doors, find the center most stile by locating the center most hinge.

Using the bottom hole of the lift handle, measure up 3" from the bottom of bottom section. Mark the hole locations and drill (2) 9/32" dia. holes through the bottom section. On the outside of the door, insert (2) 1/4" - 20 x 2-1/2" carriage bolts (black head) into the outside lift handle and insert the assembly into the (2) pre-drilled holes in the bottom section. From the inside, slide the (2) holes in the inside lift handle over the stems of the carriage bolts. Secure the outside and inside lift handle to the bottom section with (2) 1/4" - 20 flange hex nuts.

INTERMEDIATE I SECTION: Locate the exterior center stile or center most stile on the Intermediate I section. Mark a vertical line on the section at that point.

NOTE: Some Garage Doors may require both lift handles to be installed on bottom section. If your bottom section height is 28" or 29", install both lift handles onto the bottom section. Install bottom lift handle per above instructions, then install the second lift handle a Minimum of 20" and a Maximum of 30" above the bottom lift handle.

Measure up 4" from the bottom of the Intermediate I section. Using this measurement as a guide, position the bottom hole of the lift handle bottom at the mark. Make a mark at the top hole of the lift handle. This should give you a Minimum of 20" and a Maximum of 30" between the lower lift handle and the middle of the top lift handle. If needed, reposition the lift handle to stay within the Minimum and Maximum dimensions, as stated above.

Using the lift handle as a template, mark the hole locations and drill (2) 9/32" dia. holes through the section. On the outside of the door, insert (2) 1/4" - 20 x 2-1/2" carriage bolts (black head) into the outside lift handle and insert the assembly into the (2) pre-drilled holes in the section. From the inside, slide the (2) holes in the inside lift handle over the stems of the carriage bolts. Secure the outside and inside lift handle to the section with (2) 1/4" - 20 flange hex nuts.

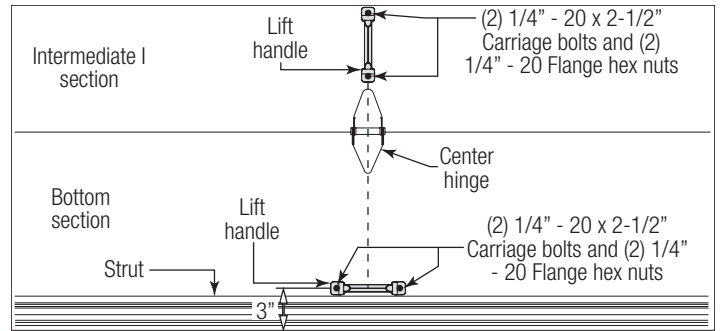

Pull Down Rope



DO NOT INSTALL PULL DOWN ROPE ON DOORS WITH OPERATORS. CHILDREN MAY BECOME ENTANGLED IN THE ROPE CAUSING SEVERE OR FATAL INJURY.

Measure and mark the jamb approximately 48" to 50" (1220 to 1270 mm) from floor on the right or left side of jamb. Drill 1/8" pilot hole for no. 6 screw eye. Tie the pull down rope to the no. 6 screw eye and to the bottom corner bracket, as shown.

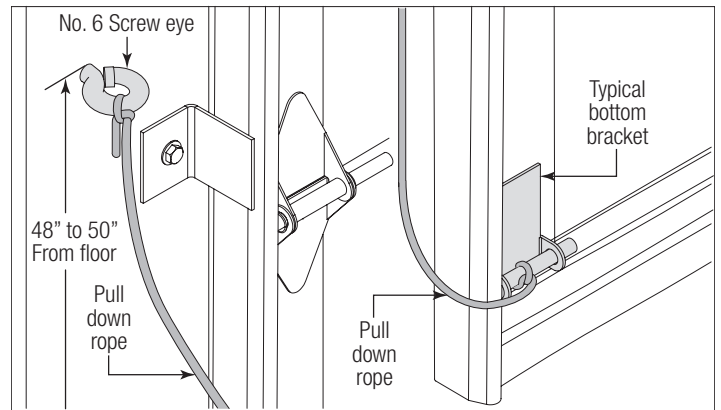

MAINTENANCE

Cleaning Your Garage Door

NOTICE

DO NOT USE A PRESSURE WASHER ON YOUR GARAGE DOOR!

An annual inspection of all the surfaces of your garage door(s) will reveal the extent of weathering and the possible need for refinishing. When the finish becomes eroded or thin, clean and prime any areas showing deterioration. Then completely refinish the door, according to the directions, listed below, or the manufacturer's label directions. Proper finishing of the wood substrates to protect your door(s) from the effects of moisture and sunlight is vital in extending the service life and beautifying your garage door(s).

The interior and exterior surfaces, as well as all edges must be properly primed, painted and maintained, to protect and beautify your door. These finishing instructions are intended to achieve both objectives for your wood doors(s).

NOTICE

BE SURE TO CLEAN BEHIND WEATHER-STRIPS ON BOTH SIDES AND TOP OF DOOR.

NOTICE

NEVER MIX CLEANSERS OR DETERGENTS WITH BLEACH.

GLASS CLEANING INSTRUCTIONS

Clean with a mild detergent solution (same as above) and a soft cloth. After cleaning, rinse thoroughly.

ACRYLIC CLEANING INSTRUCTIONS

Clean acrylic glazing with nonabrasive soap or detergent and plenty of water. Use your bare hands to feel and dislodge any caked on particles. A soft, grit-free cloth, sponge or chamois may be used to wipe the surface. Do not use hard or rough cloths that will scratch the acrylic glazing. Dry glazing with a clean damp chamois.

NOTICE

DO NOT USE ANY WINDOW CLEANING FLUIDS, SCOURING COMPOUNDS, GRITTY CLOTHS OR SOLVENT-BASED CLEANERS OF ANY KIND.

To clean polycarbonate windows, see www.Wayne-Dalton.com.

Painting Your Garage Door

Refer to Instruction Insert "[Field Painting Wood Door Sections](#)".

Maintaining The Finish On Your Garage Door

NOTE: If the finish is beginning to fade, the door may require a field applied top clear coat. Depending on environment and usage, this may be necessary after 1 to 3 years of use. Refer to Instruction Insert "[Field Painting Wood Door Sections](#)".

Operation And Maintenance

Operating Your Garage Door:

Before you begin, read all warning labels affixed to the door and the installation instructions and owner's manual. When correctly installed, your Wayne Dalton door will operate smoothly. Always operate your door with controlled movements. Do not slam your door or throw your door into the open position, this may cause damage to the door or its components. If your door has an electric opener, refer to the owner's manual to disconnect the opener before performing manual door operation below.

Manual Door Operation:

For additional information on manual garage door operation go to www.dasma.com and reference TDS 165.



DO NOT PLACE FINGERS OR HANDS INTO SECTION JOINTS WHEN OPENING AND/OR CLOSING A DOOR. ALWAYS USE LIFT HANDLES/SUITABLE GRIPPING POINTS WHEN OPERATING THE DOOR MANUALLY.

OPENING A DOOR: Make sure the lock (if present) are in the unlocked position. Lift the door by using the lift handles/suitable gripping points only. Door should open with little resistance.

CLOSING A DOOR: From inside the garage, pull door downward using lift handles/gripping points only. If you are unable to reach the lift handles/suitable gripping points only, use pull-down rope (if present) affixed to the side of door. Door should close completely with little resistance.

Using An Electric Operator:

IMPORTANT: If present, Pull-down rope must be removed and locks must be removed or made inoperative in the unlocked position.

When connecting a drawbar (trolley-type) garage door operator to this door, a drawbar operator bracket must be securely attached to the top section of the door, along with any struts provided with the door. Always use the drawbar operator bracket supplied with the door. To avoid possible damage to your door, reinforce the top section with a strut (may or may not be supplied). The installation of the drawbar operator must be according to manufacturer's instructions and force settings must be adjusted properly. Refer to the owner's manual supplied with your drawbar operator for complete details on installation, operation, maintenance and testing of the operator.

Maintaining Your Garage Door:

Before you begin, read all warning labels affixed to the door and the installation instructions and owner's manual. Perform routine maintenance steps once a month, and have the door professionally inspected once a year. Review your Installation Instructions and Owner's Manual for the garage door. These instructions are available at no charge from Wayne Dalton, a division of Overhead Door Corporation, P.O. Box 67, Mt. Hope, OH, 44660, or at www.Wayne-Dalton.com. For additional information on garage door/operator maintenance go to www.dasma.com and reference TDS 151, 167 and 179.

Monthly Inspections:

1. Visual Inspection:

Closely inspect jambs, header and mounting surface. Any material found not to be structurally sound must be replaced. It may be necessary to uninstall part or all of the door assembly in order to replace defective material. Refer to the supplemental instructions "Removing an Existing Door/Preparing the Opening" at www.Wayne-Dalton.com. Inspect the spring(s), counterbalance lift cables, track rollers, pulleys, rear back hangs and other door hardware for signs of worn or broken parts. Tighten any loose screws and/or bolts, except on bottom corner brackets or on the counterbalance assembly. Check exterior surface of the door sections for any minor cracks. Verify door has not shifted right or left in the opening. If you suspect problems, contact a trained door system technician.



GARAGE DOOR SPRINGS, COUNTERBALANCE LIFT CABLES, BRACKETS, AND OTHER HARDWARE ATTACHED TO THE SPRINGS ARE UNDER EXTREME TENSION, AND IF HANDLED IMPROPERLY, CAN CAUSE DEATH OR SERIOUS INJURY. ONLY A TRAINED DOOR SYSTEMS TECHNICIAN SHOULD ADJUST THEM, BY CAREFULLY FOLLOWING THE MANUFACTURER'S INSTRUCTIONS.

! WARNING

NEVER REMOVE, ADJUST, OR LOOSEN THE BOLTS, SCREWS AND/OR LAG SCREWS ON THE COUNTERBALANCE (END BEARING BRACKETS, DRUMS OR SPRING SYSTEM) OR BOTTOM CORNER BRACKETS OF THE DOOR. THESE BRACKETS ARE CONNECTED TO THE SPRING(S) AND ARE UNDER EXTREME TENSION. TO AVOID POSSIBLE DEATH OR SERIOUS INJURY, HAVE ANY SUCH WORK PERFORMED BY A TRAINED DOOR SYSTEMS TECHNICIAN USING PROPER TOOLS AND INSTRUCTIONS.

Torsion Springs:

The torsion springs (located above the door) should only be adjusted by a trained door systems technician. **DO NOT** attempt to repair or adjust torsion springs yourself.

2. Door Balance:

Periodically test the balance of your door. If you have a garage door drawbar operator, use the release mechanism so you can operate the door by hand when doing this test. Start with the door in the fully closed position. Using handles or suitable gripping points, lift the door to check its balance. If door lifts by itself (hard to pull down) or if door is difficult to lift (easy to pull down), have it adjusted by a trained door systems technician. **DO NOT** attempt to repair or adjust Torsion Springs yourself.

3. Lubrication:

The door should open and close smoothly. Ensure the door track rollers are rotating freely when opening and closing the door. If track rollers do not rotate freely, clean the door tracks, removing dirt and any foreign substances. Clean and lubricate (use a non-silicon based lubricant) graduated end hinges, center hinges, steel track rollers, bearings and torsion springs (torsion spring coil surfaces). **DO NOT** lubricate plastic idler bearings, nylon track rollers, or the door track. **DO NOT** oil a cylinder lock. If actuation is difficult, use a graphite dust to lubricate.

Check for Presence of Safety Labels:

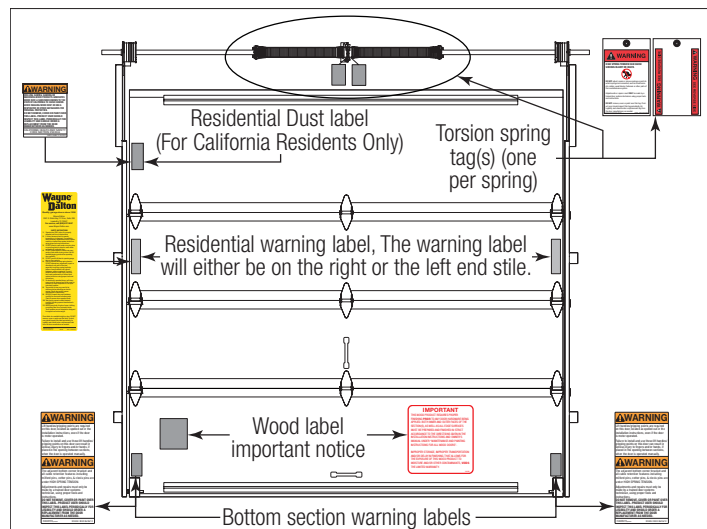



Models 105/110, 106/116, 310/311, and 314-316

Limited Warranty

Wayne Dalton, a division of Overhead Door Corporation ("Seller") warrants to the original purchaser of **Models 105, 110, 106, 116, 310, 311, 314, and 316** ("Product"), subject to all of the terms and conditions hereof, that the Product and all components thereof will be free from defects in materials and workmanship for a period of **One (1) year**, measured from the date of installation:

Seller's obligation under this warranty is specifically limited to repairing or replacing, at its option, any part which is determined by Seller to be defective during the applicable warranty period. Any labor charges are excluded and will be the responsibility of the purchaser.

This warranty gives you specific legal rights, and you may also have other rights which vary from state to state. This warranty is made to the original purchaser of the Product only, and is not transferable or assignable. This warranty applies only to Product installed in a residential or other non-commercial application. It does not cover any Product installed in commercial or industrial building applications. This warranty does not apply to any unauthorized alteration or repair of the Product, or to any Product or component which has been damaged or deteriorated due to misuse, neglect, accident, puncture, drilling of holes (other than as directed by Seller), incorrect installation of hardware, fire, failure to provide necessary maintenance, normal wear and tear, exposure to salt or other corrosive environments, or acts of God or any other cause beyond the reasonable control of Seller. This warranty also specifically excludes all refinishing costs and any inconsistencies or occurrences related to the characteristics or attributes of natural wood, including but not limited to: (i) variations in the color or grain of Product sections, (ii) the emission or secretion of tannins from the Product sections which may stain or alter the color of a painted Product, and (iii) cracking, checking, lifting wood grain or cracking due to natural expansion and contraction of the Product sections.

SPECIAL PAINTING REQUIREMENTS: This warranty shall be void if the Product sections are not painted or sealed in accordance with DASMA TDS 162 (available at www.dasma.com) on all sides, including all edges with one (1) coat of exterior grade primer (or stain) and two (2) coats of high quality acrylic latex exterior grade finish paint (or sealer), applied in accordance with the paint or Sealer manufacturer's instructions and Seller's painting and maintenance instructions. Sections must be finished within five (5) days of receipt and prior to installation. Damage caused by exposure of the product to water, moisture, sun or other conditions prior to completion of painting (or Sealing) is excluded. This warranty shall also be void if the Product is painted a dark color, including but not limited to black, dark grey, dark green and dark brown*. **IMPROPER TRANSPORTATION, STORAGE OR DELAYS IN FINISHING, THAT ALLOWS EXPOSURE OF THE WOOD DOOR SURFACES TO MOISTURE OR OTHER CONTAMINANTS WILL RESULT IN THE WARRANTY BEING VOIDED.**

ALL EXPRESS AND IMPLIED WARRANTIES FOR THE PRODUCT, INCLUDING BUT NOT LIMITED TO ANY IMPLIED WARRANTIES OF MERCHANTABILITY AND FITNESS FOR A PARTICULAR PURPOSE, ARE LIMITED IN TIME TO THE APPLICABLE WARRANTY PERIOD REFLECTED ABOVE. NO WARRANTIES, WHETHER EXPRESS OR IMPLIED, WILL APPLY AFTER THE LIMITED WARRANTY PERIOD HAS EXPIRED. Some states do not allow limitations on how long an implied warranty lasts, so the above limitation may not apply to you.

IN NO EVENT SHALL SELLER BE RESPONSIBLE FOR, OR LIABLE TO ANYONE FOR, SPECIAL, INDIRECT, COLLATERAL, PUNITIVE, INCIDENTAL OR CONSEQUENTIAL DAMAGES, even if Seller has been advised of the possibility of such damages. Such excluded damages include, but are not limited to, loss of use, cost of any substitute product, or other similar indirect financial loss. Some states do not allow the exclusion or limitation of incidental or consequential damages, so the above limitation or exclusion may not apply to you.

Claims under this warranty must be made promptly after discovery, within the applicable warranty period, and in writing to the Seller whose name and address appear below. The purchaser must allow Seller a reasonable opportunity to inspect any Product claimed to be defective prior to removal or any alteration of its condition. Proof of the purchase and/or installation date, and identification as the original purchaser, may be required. There are no established informal dispute resolution procedures of the type described in the Magnuson-Moss Warranty Act.

* Dark colors shall mean colors as dark as or darker than any of the following Sherwin-Williams Exterior Colors: 7069 Iron Ore (dark grey), 6447 Evergreens (dark green) or 7510 Chateau Brown (dark brown).

SELLER: _____

SELLER'S ADDRESS: _____

Thank you for your purchase.

PLEASE DO NOT RETURN THIS PRODUCT TO THE STORE

If you need assistance, please call 1-866-569-3799 (press Option 1) and follow the prompts to contact a customer service representative. They will be happy to handle any questions that you may have.

After installation is complete, leave this Installation Instructions And Owner's Manual with the homeowner, or fasten it near garage door for easy reference.