

**INSTALLATION INSTRUCTIONS AND OWNER'S MANUAL**

**Models 9100 / 9405 / 9605**

**RESIDENTIAL**  
**STANDARD LIFT, WINDLOAD**

**TORSION**

**DEFINITION OF LIGHT COMMERCIAL:**

1. Door heights less than or equal to 8'0" ( $\leq 8'0"$ ) are considered Residential applications.
2. Door heights greater than 8'0" ( $> 8'0"$ ) are considered Light Commercial applications.

**PLEASE DO NOT RETURN THIS PRODUCT TO**  
**THE STORE**

If you need assistance, please call 1-866-569-3799 (press Option 1) and follow the prompts to contact a customer service representative. They will be happy to handle any questions that you may have.

**IMPORTANT NOTICES!**

Carefully read and fully understand the enclosed instructions before installing and operating the garage door.

Pay close attention to all warnings and notes.

After installation is complete, fasten this manual near garage door for easy reference.

This Installation document is available at no charge from:

- Your local Wayne Dalton Sales Center
- Online at **[www.Wayne-Dalton.com](http://www.Wayne-Dalton.com)**
- By mailing a request to: Wayne Dalton, a division of Overhead Door Corporation, P.O. Box 67, Mt. Hope, OH., 44660

# Table Of Contents

<b>PRE-INSTALLATION</b>	<b>3</b>
Important Safety Instructions	3
<b>REMOVING AN EXISTING DOOR AND PREPARING THE OPENING</b>	<b>5</b>
Package Contents	6
Door Section Identification	8
Tools Required	8
<b>BREAKDOWN OF DOOR COMPONENTS</b>	<b>9</b>
<b>BREAKDOWN OF COUNTERBALANCE COMPONENTS</b>	<b>10</b>
<b>INSTALLATION INSTRUCTIONS</b>	<b>11</b>
Door Installation Instructions	11
Counterbalance Installation Instructions	21
<b>OPTIONAL INSTALLATION</b>	<b>31</b>
Door Arm Hookup	31
Trolley Arm Configuration	31
Inside Lock	31
Pull Down Rope	32
Step Plate	32
<b>MAINTENANCE</b>	<b>33</b>
Cleaning Your Garage Door	33
Painting Your Garage Door	33
Maintaining The Finish On Your Garage Door	33
Operation And Maintenance	33
<b>WARRANTY</b>	<b>35</b>

## Important Safety Instructions

### DEFINITION OF KEY WORDS USED IN THIS MANUAL:

#### **DANGER**

INDICATES A HAZARDOUS SITUATION THAT, IF NOT AVOIDED, WILL RESULT IN DEATH OR SERIOUS INJURY.

#### **WARNING**

INDICATES A HAZARDOUS SITUATION THAT, IF NOT AVOIDED, COULD RESULT IN DEATH OR SERIOUS INJURY.

#### **CAUTION**

INDICATES A HAZARDOUS SITUATION THAT, IF NOT AVOIDED, COULD RESULT IN MINOR OR MODERATE INJURY.

#### **NOTICE**

INDICATES INFORMATION CONSIDERED IMPORTANT, THAT IT IS NOT RELATED TO INJURY, BUT MAY RESULT IN PROPERTY DAMAGE.

**IMPORTANT:** Required key step for proper door operation.

**NOTE:** Information only.

### Installation:

#### **WARNING**

INSTALLING THIS DOOR PROPERLY REQUIRES THE USE OF SPECIAL TOOLS AND TECHNIQUES. ALWAYS USE THE CORRECT TOOLS OR TECHNIQUES WHEN PERFORMING INSTALLATION. FAILURE TO USE PROPER TOOLS OR TECHNIQUES OR ADHERE TO SAFETY MESSAGES, COULD RESULT IN SEVERE OR FATAL INJURY.

#### **DANGER**

EXTREME CAUTION SHOULD BE USED WHEN WINDING SPRINGS AS FAILURE TO FOLLOW THE INSTRUCTIONS OR USE THE PROPER TOOLS CAN LEAD TO SERIOUS INJURY TO PERSONS AND PROPERTY. BEFORE ATTEMPTING TO WIND THE SPRING, MAKE SURE YOU HAVE READ AND UNDERSTAND THE INSTRUCTIONS. IF YOU ARE UNCLEAR ON ANY ASPECT OF THE INSTALLATION PROCEDURES, YOU SHOULD CONSULT A TRAINED DOOR SYSTEMS TECHNICIAN.

- READ THESE INSTRUCTIONS CAREFULLY BEFORE ATTEMPTING INSTALLATION. IF YOU ARE IN QUESTION ABOUT ANY OF THE PROCEDURES, DO NOT PERFORM THE WORK. INSTEAD, HAVE A TRAINED DOOR SYSTEMS TECHNICIAN DO THE INSTALLATION OR REPAIRS.
- Wear protective gloves and eye protection during installation, to avoid possible injury.
- **DO NOT** install door in windy conditions. Door could fall during the installation, causing severe or fatal injury.
- Doors 12'-0" wide and larger should be installed by two persons, to avoid possible injury.
- On electrically operated doors, pull down ropes must be removed and locks must be removed or made inoperative in the open (unlocked) position, unless electrical interlocks are installed.
- Impact guns are not recommended. When installing 5/16" lag screws using an electric drill/ driver, the drill/ drivers clutch must be set to deliver no more than 200 in-lbs of torque. Fastener failure could occur at higher settings.
- Check with your local building official for wind load code requirements and building permit information.
- For windloaded doors, the wind performance is achieved via the entire door system and component substitution is not authorized without express permission by the manufacturer.

#### **CAUTION**

IF ANY PART OF THE DOOR IS TO BE INSTALLED ONTO PRESERVATIVE-TREATED WOOD, PTFE-COATED OR STAINLESS STEEL FASTENERS MUST BE OBTAINED AND USED. REPLACEMENT FASTENERS MUST BE OF AT LEAST EQUAL STRENGTH AND SIZE AS ORIGINAL FASTENERS. IF THE ORIGINAL FASTENER WAS RED-HEAD, THE REPLACEMENT FASTENER MUST BE RED-HEAD ALSO. CONTACT WAYNE DALTON FOR FASTENER STRENGTH VALUES IF NEEDED.

**Operation:**

**⚠ WARNING**

**TO PREVENT DEATH OR SERIOUS INJURY WHILE OPERATING THE DOOR, ENSURE THE PATH OF THE DOOR IS NOT OBSTRUCTED BY ANY PERSON OR OBJECT AND ADHERE TO THE FOLLOWING SAFETY MEASURES.**

- Operate door only when it is properly adjusted and free from obstructions.
- If a door becomes hard to operate, inoperative or is damaged, immediately have necessary adjustments and/ or repairs made by a trained door system technician using proper tools and instructions.
- **DO NOT** stand or walk under a moving door, or permit anybody to stand or walk under an electrically operated door.
- **DO NOT** place fingers or hands into open section joints when closing a door. Use lift handles/ gripping points when operating door manually.
- **DO NOT** permit children to operate garage door or door controls. Severe or fatal injury could result should the child become entrapped between the door and the floor.
- Visually inspect door and hardware monthly for worn and or broken parts. Check to ensure door operates freely. Test electric opener's safety features monthly, following opener manufacturer's instructions.
- **NEVER** hang tools, bicycles, hoses, clothing or anything else from horizontal tracks. Track systems are not intended or designed to support extra weight.

Potential Hazard	Effect	Prevention
 <p>Moving door</p>	<p><b>⚠ WARNING</b></p> <p>Could result in Death or Serious Injury</p>	<p>Keep people clear of opening while Door is moving.</p> <p>Do <b>NOT</b> allow children to play with the Door Opener.</p> <p>Do <b>NOT</b> operate a Door that jams or one that has a broken spring.</p>
 <p>High tension spring</p>	<p><b>⚠ DANGER</b></p> <p>Will result in Death or Serious Injury</p>	<p>Do <b>NOT</b> try to remove, install, repair or adjust springs or anything to which door spring parts are fastened, such as, wood blocks, steel brackets, cables or other like items.</p> <p>Installations, repairs and adjustments must be done by a trained door system technician using proper tools and instructions.</p>

**IMPORTANT:** RIGHT and LEFT hand is determined inside the building looking out.

# REMOVING AN EXISTING DOOR AND PREPARING THE OPENING

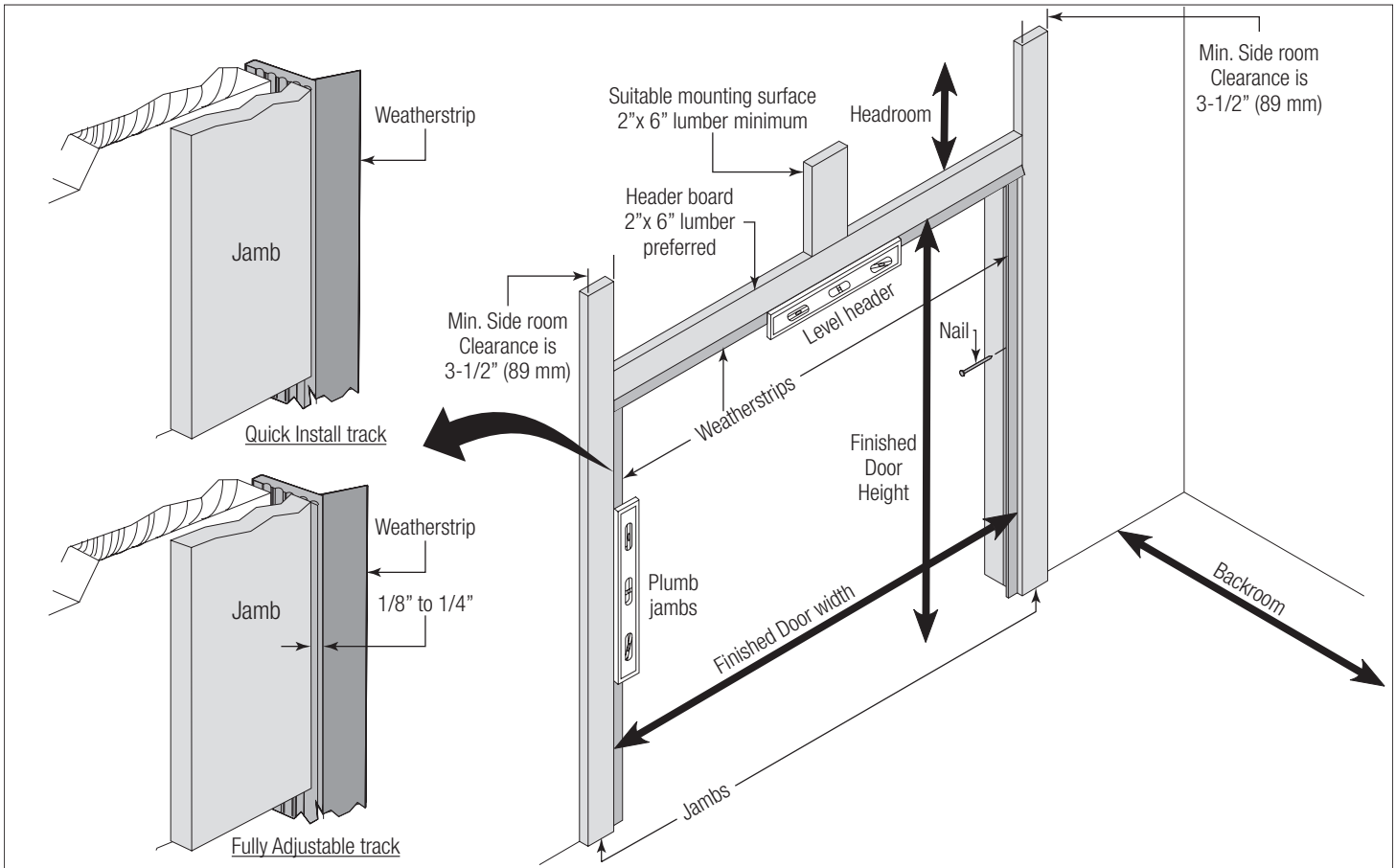

Figure 1

See Figure 1 for the following steps.

To ensure secure mounting of track brackets, side and center brackets, or steel angles to new or retro-fit construction, it is recommended to follow the procedures outlined in DASMA technical data sheets #156, #161 and #164 at [www.dasma.com](http://www.dasma.com).

- The inside perimeter of your garage door opening should be framed with wood jamb and header material.
- The jambs and header must be securely fastened to sound framing members. It is recommended that 2" x 6" lumber be used. The jambs must be plumb and the header level.
- The jambs should extend a minimum of 12" (305 mm) above the top of the opening for Torsion counterbalance systems.
- For low headroom applications, the jambs should extend to the ceiling height. Minimum side clearance required, from the opening to the wall, is 3-1/2" (89 mm).

## NOTICE

CLOSELY INSPECT JAMBS, HEADER AND MOUNTING SURFACE. ANY WOOD FOUND NOT TO BE SOUND, MUST BE REPLACED.

For Torsion counterbalance systems, a suitable mounting surface (2" x 6") must be firmly attached to the wall, above the header at the center of the opening.

## NOTICE

DRILL A SUITABLE PILOT HOLE IN THE MOUNTING SURFACE TO AVOID SPLITTING THE LUMBER. DO NOT ATTACH THE MOUNTING SURFACE WITH NAILS.

## DANGER

**AVOID INJURY! A POWERFUL SPRING RELEASING ITS ENERGY SUDDENLY CAN CAUSE SEVERE OR FATAL INJURY. ALWAYS HAVE A TRAINED DOOR SYSTEMS TECHNICIAN, USING PROPER TOOLS AND INSTRUCTIONS, RELEASE THE SPRING TENSION.**

## WARNING

**TO AVOID POSSIBLE INJURY AND TO ENSURE PROPER INSTALLATION, IT'S HIGHLY RECOMMENDED THAT YOU READ AND FULLY UNDERSTAND THE COMPLETE INSTRUCTIONS ON REMOVING AN EXISTING DOOR & PREPARING THE OPENING. THESE ARE AVAILABLE FOR DOWNLOAD AT [WWW.WAYNE-DALTON.COM](http://WWW.WAYNE-DALTON.COM) OR AT YOUR LOCAL WAYNE DALTON SALES CENTER.**

## DANGER

**COUNTERBALANCE SPRING TENSION MUST ALWAYS BE RELEASED BEFORE ANY ATTEMPT IS MADE TO START REMOVING AN EXISTING DOOR. EXTREME CAUTION SHOULD BE USED WHEN UNWINDING SPRINGS AS FAILURE TO FOLLOW THE INSTRUCTIONS OR USE PROPER TOOLS CAN LEAD TO SERIOUS INJURY.**

**Weatherstrips (Not Included):**

Depending on the size of your door, you may have to cut or trim the weatherstrips to properly fit into the header and jambs.

**NOTICE**

IF NAILING PRODUCT AT 40°F, (4.4°C) OR BELOW, PRE-DRILLING IS REQUIRED.

1. For the header, align the weatherstrip with the inside edge of the header and temporarily secure it to the header with equally spaced nails, approximately 12" to 18" (305 mm - 457 mm) apart.

2. Starting at either side of the jamb, fit the weatherstrip up tight against the temporarily attached weatherstrip in the header and flush with the inside edge of the jamb.

3. Temporarily secure the weatherstrip with equally spaced nails. Repeat for other side. This will keep the bottom door section from falling out of the opening during installation.

**Headroom requirement:**

Headroom required is defined as the space needed above the top of the door for tracks, springs, etc. to allow the door to open properly.

**NOTE:** 6" low headroom conversion kit is available for 12" radius only. Contact your local Wayne Dalton dealer.

If the door is to be motor operated, 2-1/2" (64 mm) of additional headroom is required.

TRACK TYPE	SPACE NEEDED
15" Radius track	14-1/2" (368 mm)
12" Radius track	13-1/2" (343 mm)
6" LHR KIT	6" (152 mm)

**Backroom requirement:**

Backroom required is defined as the distance needed from the opening back into the garage to allow the door to open fully.

**\*NOTE:** For door heights from 10'1" to 14'0", refer to your operator manufacture installation instructions for appropriate depth into room.

DOOR HEIGHT	TRACK	MANUAL LIFT	MOTOR OPERATED
6'5" to 7'0"	12",15" Radius	102" (2591 mm)	125" (3175 mm)
7'1" to 8'0"	12",15" Radius	114" (2896 mm)	137" (3480 mm)
8'1" to 9'0"	12",15" Radius	126" (3200 mm)	168" (4267 mm)
9'1" to 10'0"	12",15" Radius	138" (3505 mm)	168" (4267 mm)
10'1" to 12'0"	12",15" Radius	162" (4115 mm)	See <b>*NOTE</b>
12'1" to 14'0"	12",15" Radius	186" (4724 mm)	See <b>*NOTE</b>

**Package Contents**

**NOTE:** Depending on the door model, some parts listed may not be required, and will not be supplied.

**Components and Hardware**

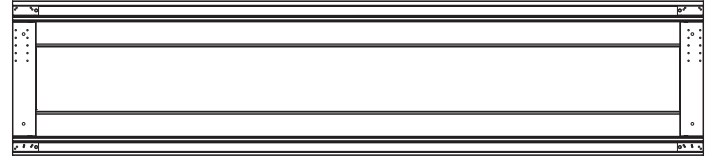

(E1. - E7.) Door sections (as required)



(J9.) Torsion shaft / Torsion keyed shaft (as required)



(J10.) Torsion keyed shafts (as required)

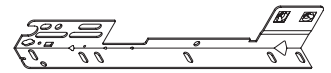

(A1.) Quick Install flag angles RH/LH (as required)



(I2.) Horizontal track angles (as required)

(A2.) Fully Adjustable flag angles RH/LH (as required)



(I1.) Horizontal tracks



(I3.) Vertical tracks RH/LH (as required)



(I4.) Riveted vertical track assemblies RH/LH (as required)



(I5.) Angle mount vertical track assemblies RH/LH (as required)



(B1.) Q.I. jamb brackets (as required)

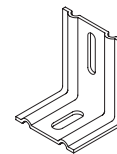

(B2.) F.A. jamb brackets (as required)

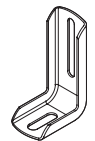

(B3.) Winload jamb brackets (as required)

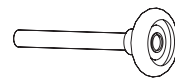

(C1.) (C2.) Track rollers (as required)

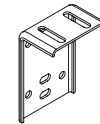

(F1.) Top fixture bases (as required)

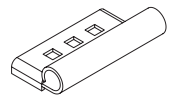

(F2.) Top fixture slides (as required)

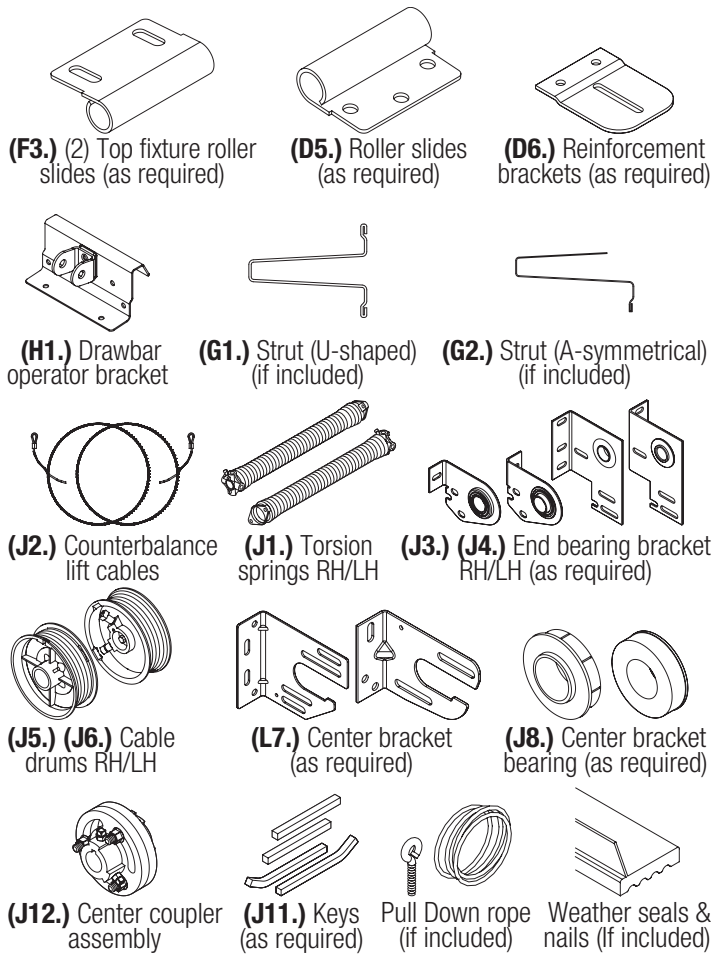

**Figure 2**

**Fasteners**

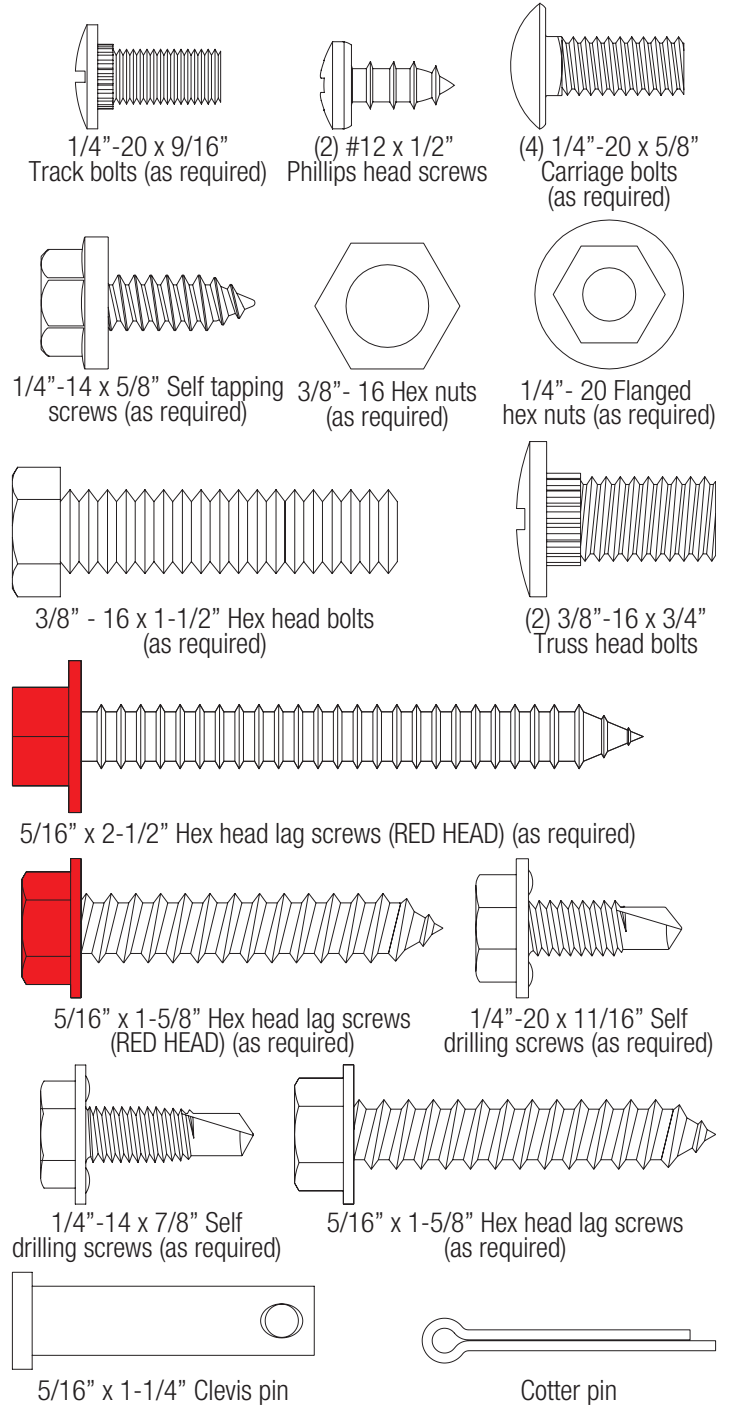

**Figure 3**

## Door Section Identification

See Figure 4 and Figure 7 for the following steps.

End and center hinges are always pre-attached at the top of each section (except top section).

- The **BOTTOM SECTION (E7.)** can be identified by the factory attached bottom weather seal, the factory attached bottom corner brackets, and by the bottom corner bracket warning labels on each end stile.
- The **SECOND (LOCK) SECTION (E6.)** can be identified having no labels attached to the section.
- The **INTERMEDIATE I SECTION (E5.)** can be identified by the warning label attached to either the right or left hand end stile.
- The **INTERMEDIATE II SECTION (E4.)** can be identified having no labels attached to the section.
- The **INTERMEDIATE III SECTION (E3.)** can be identified having no labels attached to the section.
- The **INTERMEDIATE IV SECTION (E2.)** can be identified having no labels attached to the section.
- The **TOP SECTION (E1.)** can be identified with no pre-installed graduated end or center hinges.

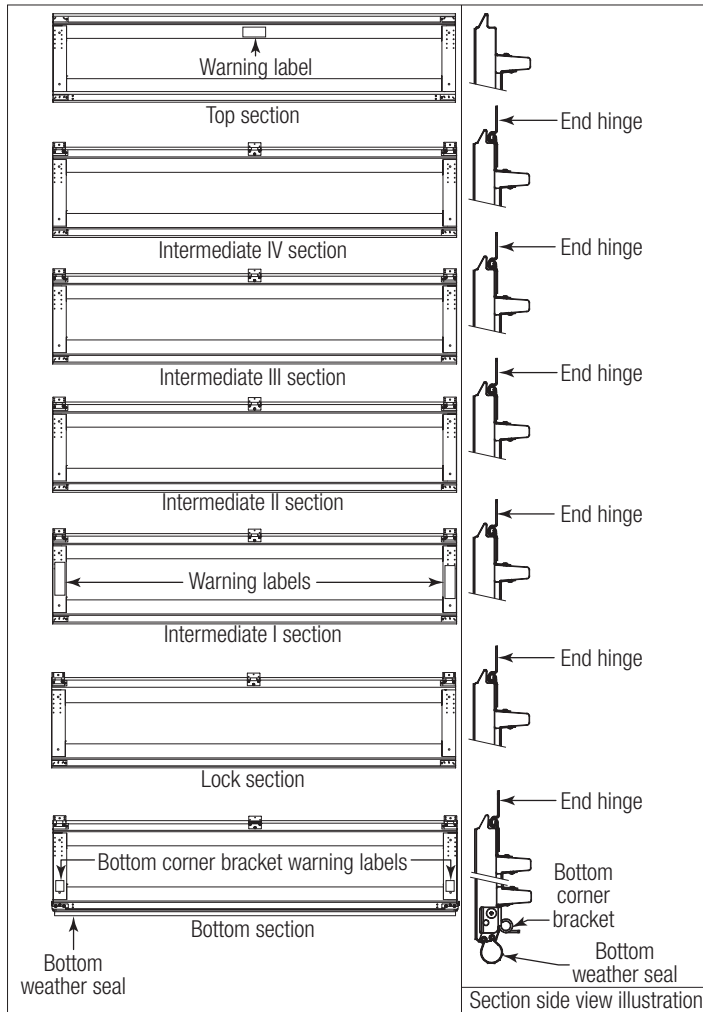

Figure 4

## Tools Required

### Personal Protection Equipment (PPE)



Figure 5

### Hand Tools

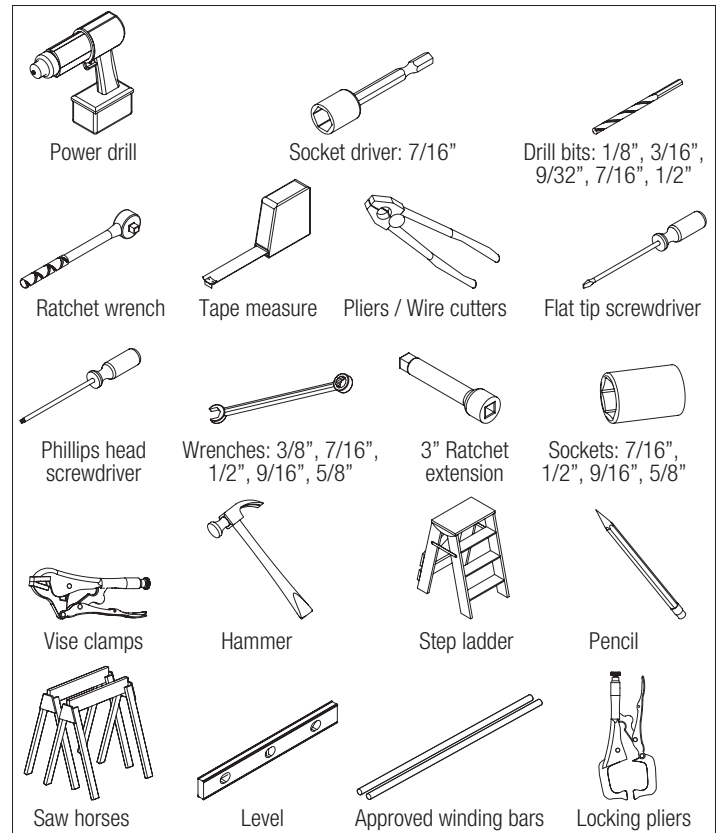
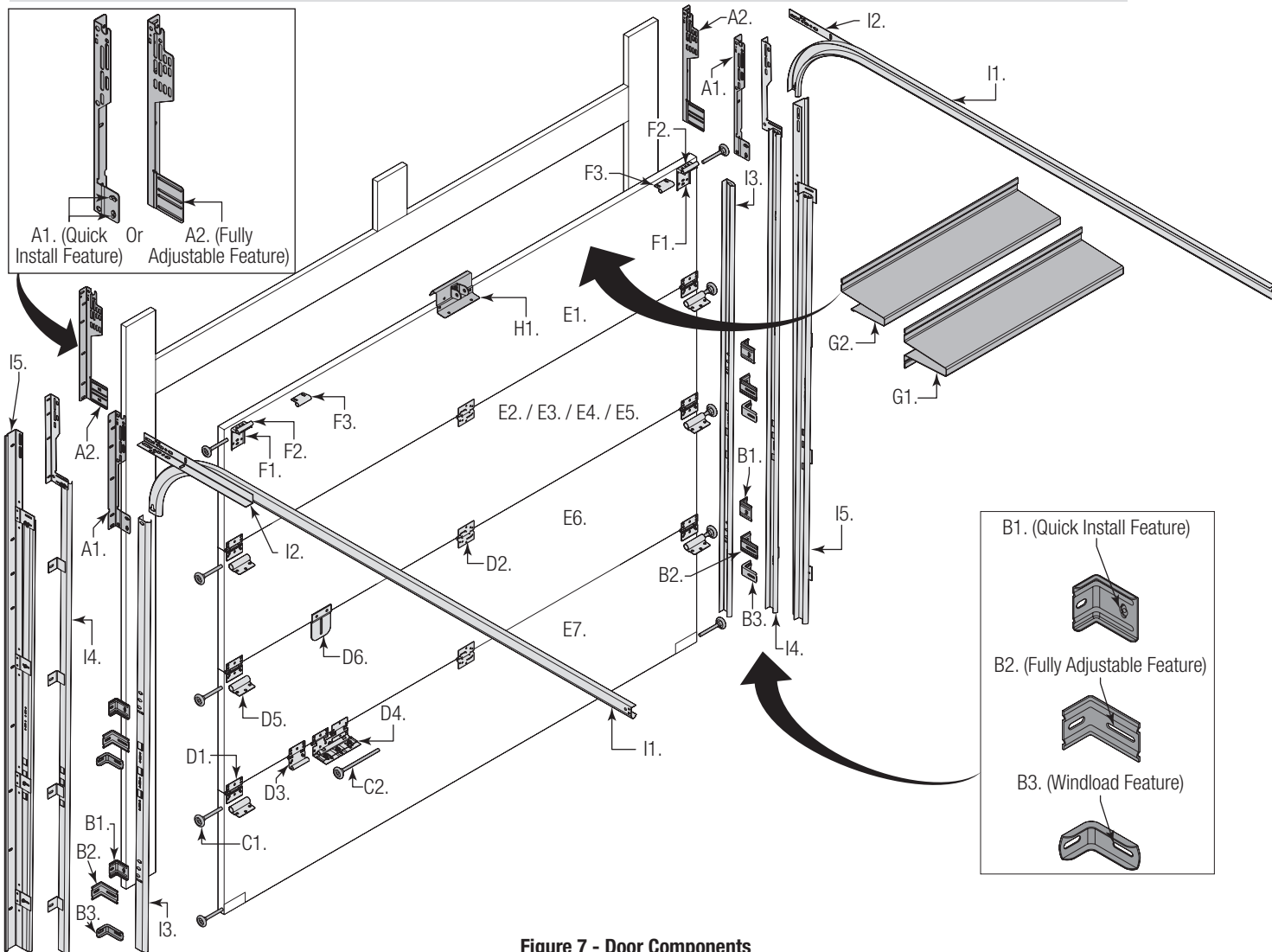

Figure 6



# BREAKDOWN OF DOOR COMPONENTS

**NOTE:** The illustrations shown on this page are general representations of the door parts. Each specific door models may have unique variations.



**Figure 7 - Door Components**

**A. FLAG ANGLES (AS REQUIRED):**

- A1. Quick Install (Q.I.) Flag Angles
- A2. Fully Adjustable (F.A.) Flag Angles

**B. JAMB BRACKETS (AS REQUIRED):**

- B1. Quick Install (Q.I.) Jamb Brackets
- B2. Fully Adjustable (F.A.) Jamb Brackets
- B3. Windload Jamb Brackets

**C. TRACK ROLLERS (AS REQUIRED):**

- C1. Short Stem Track Rollers
- C2. Long Stem Track Rollers

**D. GRADUATED END HINGES:**

- D1. End Hinges
- D2. Center Hinges
- D3. Single Graduated End Hinges (S.E.H.), Anti-Pinch
- D4. Double Graduated End Hinges (D.E.H.), Anti-Pinch
- D5. Roller slides
- D6. Reinforcement brackets

**E. STACKED SECTIONS:**

- E1. Top Section

- E2 - E5. Intermediate(s) Section

- E6. Second (Lock) Section

- E7. Bottom Section

**F. TOP FIXTURES (AS REQUIRED):**

- F1. Top Fixture Bases - (L - Shaped)
- F2. Top Fixture Slides - (L - Shaped)
- F3. Top Fixture Roller Slides

**G. STRUT(S) (AS REQUIRED):**

- G1. Strut (U - shaped)
- G2. Strut (asymmetrical)

**H. DRAWBAR OPERATOR BRACKET (FOR TROLLEY OPERATED DOORS):**

- H1. Drawbar Operator Bracket

**I. TRACKS (AS REQUIRED):**

- I1. Left and Right Hand Horizontal Track Assemblies
- I2. Left and Right Hand Horizontal Track Angles
- I3. Left and Right Hand Vertical Tracks
- I4. Left and Right Hand Riveted Vertical Track Assemblies
- I5. Left and Right Hand Angle Mount Vertical Track Assemblies

# BREAKDOWN OF COUNTERBALANCE COMPONENTS

**NOTE:** The illustrations shown on this page are general representations of the door parts. Each specific door models may have unique variations.

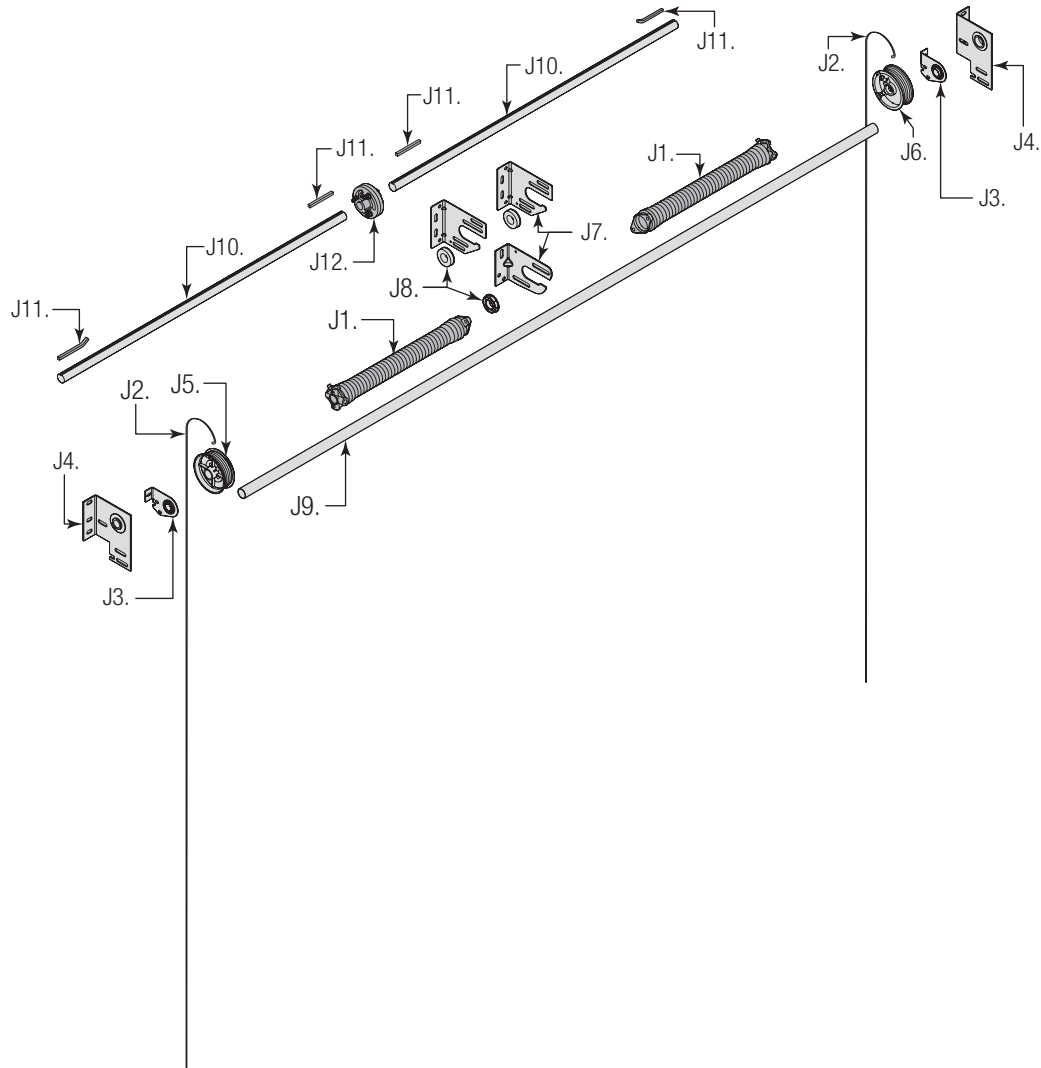

**Figure 7 - Counterbalance Components**

## **J. TORSION SPRING ASSEMBLY (AS REQUIRED):**

- J1. Left Hand and Right Hand Torsion Springs (As Required)
- J2. Counterbalance Lift Cables
- J3. Left and Right Hand End Bearing Brackets (As Required)
- J4. Left and Right Hand End Bearing Brackets (As Required)
- J5. Left Hand Cable Drum
- J6. Right Hand Cable Drum
- J7. Center Bracket(s) (As Required)
- J8. Center Bracket Bearing(s) (As Required)
- J9. Torsion Shaft / Torsion Keyed Shaft (As Required)
- J10. Torsion Keyed Shafts (As Required)
- J11. Keys (As Required)
- J12. Center Coupler Assembly (As Required)

# INSTALLATION INSTRUCTIONS

## Door Installation Instructions

**BEFORE INSTALLING YOUR DOOR, BE CERTAIN THAT YOU HAVE READ AND FOLLOWED ALL OF THE INSTRUCTIONS COVERED IN THE PRE-INSTALLATION SECTION OF THIS MANUAL. FAILURE TO DO SO MAY RESULT IN AN IMPROPERLY INSTALLED DOOR.**

**IMPORTANT:** Reference TDS 160 for general garage door terminology at [www.dasma.com](http://www.dasma.com).

### NOTICE

IF THE DOOR WILL BE EXPOSED TO A SIGNIFICANT AMOUNT OF ROAD SALT, PAINT THE BOTTOM GALVANIZED STEEL WEATHER RETAINER TO INHIBIT RUSTING.

## 1 VERTICAL TRACK ASSEMBLY

**IMPORTANT:** If you have Riveted Track, skip this step.

**NOTE:** Refer to Package Contents or Breakdown Of Parts, to determine which type of jamb bracket you received.

**NOTE:** For clarity, all graphics shown are of the left side, right side will be the same.

**IMPORTANT:** The bottom jamb bracket is always the shortest bracket, while the center jamb bracket is the next tallest. If three jamb brackets per side are included with your door, you will have received a top jamb bracket, which is the tallest.

### For Doors With Quick Install Flag Angles:

See Figure 8 and Figure 9 for the following steps.

1a. Locate the flag angle ① and align the lower Quick Install tab to the vertical track Quick Install feature ②. Rotate the flag angle 1/4 turn to lock in place ③.

**IMPORTANT:** Each jamb bracket will have a unique ID that starts with "QJJB" followed by a number. Use this number for the correct jamb bracket outlined in Table 1. Jamb Bracket Schedule. If not installed correctly, the jamb brackets won't fit up against the jamb correctly.

1b. Measure the length of the vertical tracks. Using the jamb bracket schedule in Table 1, determine the placement of the jamb brackets for your door height and track length. See Figure 8.

1c. To install the jamb brackets, align the Quick Install tab to the vertical track Quick Install feature. Rotate the jamb bracket 1/4 turn to lock in place ④.

**IMPORTANT:** Mounting flange is toward the back (flat) leg of the track.

1d. Repeat the same process for right hand side.

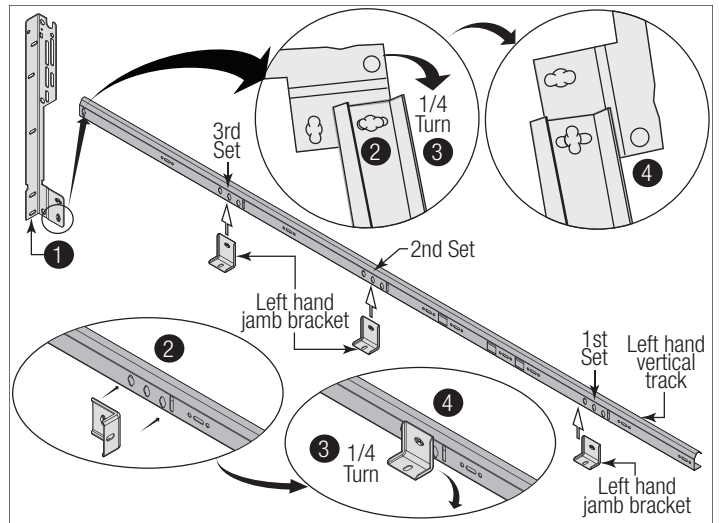

Figure 8, Left Side Shown

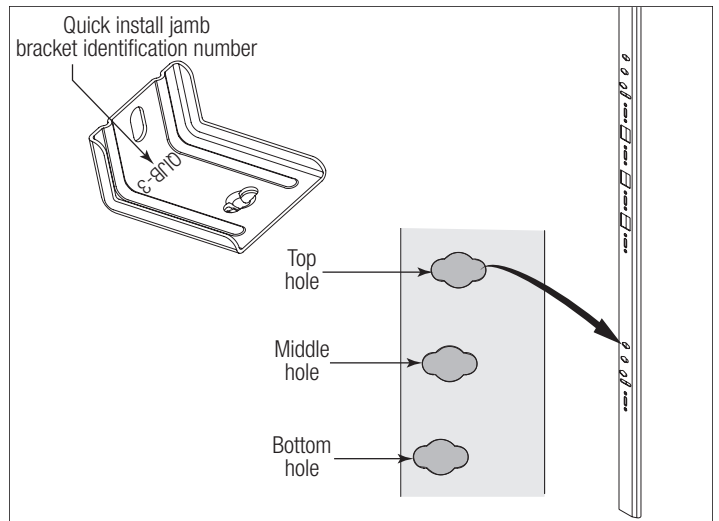

Figure 9, Left Side Shown For All Flag Angles

Table 1, Jamb Bracket Schedule

Door Height	Track Length	1st Set		2nd Set	
		Jamb Bracket	Hole Position	Jamb Bracket	Hole Position
6'0"	64" (1626 mm)	5	Middle	6	Bottom
6'5"	69" (1753 mm)	3	Bottom	6	Middle
6'8"	72" (1829 mm)	3	Bottom	6	Middle
7'0"	76" (1930 mm)	3	Bottom	7	Top
7'3"	79" (2007 mm)	3	Bottom	5	Bottom
7'6"	82" (2083 mm)	3	Bottom	5	Bottom
7'9"	85" (2159 mm)	3	Bottom	5	Bottom
8'0"	88" (2235 mm)	3	Bottom	7	Top

1	Flag Angle	3	1/4 Turn
2	Quick Install Feature	4	Lock In Place

**For Doors With Fully Adjustable Flag Angle:**

See Figure 10 and Figure 11 for the following steps.

**IMPORTANT:** Each flag angle will have a unique ID "12R or 15R". Measure the radius of your horizontal track to determine if your horizontal track is 12" or 15" Radius.

- 1a. Hand tighten the flag angle ① to the vertical track ② using two 1/4" - 20 x 9/16" track bolts ③ and two 1/4" - 20 flange hex nuts ④.
- 1b. attach the shortest jamb bracket ⑤ by aligning the slot in the shortest jamb bracket with the lower hole of the hole/ slot pattern of the vertical track. Hand tighten the jamb bracket using (1) 1/4" - 20 x 9/16" track bolt and (1) 1/4" - 20 flange hex nut.
- 1c. Place the tallest jamb bracket ⑥ over the lower hole of the hole/ slot pattern that is centered between the bottom jamb bracket and flag angle of the 2nd hole set. Hand tighten the jamb bracket using (1) 1/4" - 20 x 9/16" track bolt and (1) 1/4" - 20 flange hex nut.
- 1d. Repeat this process for the right hand side.

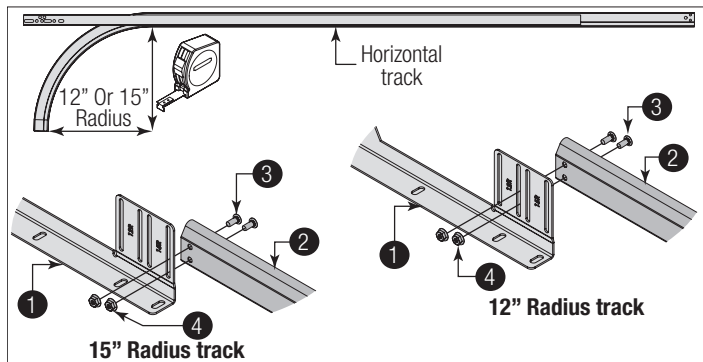

Figure 10, Left Side Shown

**IMPORTANT:** In Figure 10, observe the slot location in reference to the 12" or 15" radius.

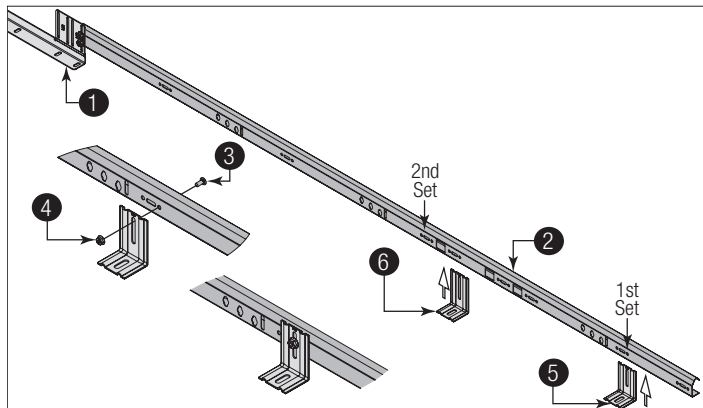

Figure 11, Left Side Shown

1	Flag Angle	4	1/4" - 20 Flange Hex Nut
2	Vertical Track	5	Shortest Jamb Bracket
3	1/4" - 20 x 9/16" Track Bolt	6	Tallest Jamb Bracket

## 2 ATTACHING HORIZONTAL TRACK ANGLES

**NOTE:** For clarity, all graphics shown are of the left side, right side will be the same.

**NOTE:** For larger doors, a full length horizontal track angle may not already be spot welded to the horizontal track. If the horizontal track angle is not welded, the horizontal track angle will be installed, as shown.

See Figure 12 for the following steps.

- 2a. Position the horizontal track angle ①, as shown.
- 2b. Place the Quick Install tabs ② of the horizontal track angle in the key slot ③ of the horizontal track ④. Using a hammer, tap the horizontal track angle towards the curved end of the track until the alignment hole in the track and angle are aligned.
- 2c. Repeat for other side. Set tracks aside.

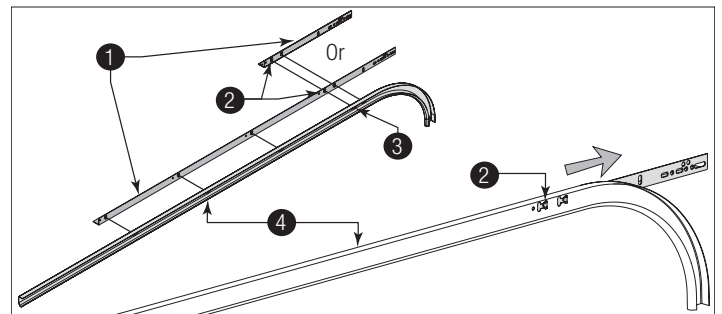

Figure 12, Left Side Shown

1	Horizontal Track Angle	3	Key Slot
2	Quick Install Tabs	4	Horizontal Track

## 3 ATTACHING (WL) JAMB BRACKETS TO VERTICAL TRACK ASSEMBLY

**NOTE:** Windload specification 0356 only uses the Quick Install (Q.I.) jamb bracket schedule.

See Figure 13 for the following steps.

- 3a. Measure the length of the vertical tracks ①.
- 3b. Using the Jamb Bracket Schedule (shown on the Windload Specification Sheet included in the hardware box), determine the placement of the windload jamb brackets ② for your door height.
- 3c. Loosely fasten the jamb bracket to the vertical track using (1) 1/4" - 20 x 9/16" track bolt ③ and (1) 1/4" - 20 flange hex nut ④. Repeat for other windload jamb brackets.
- 3d. Repeat the same process for the other side.

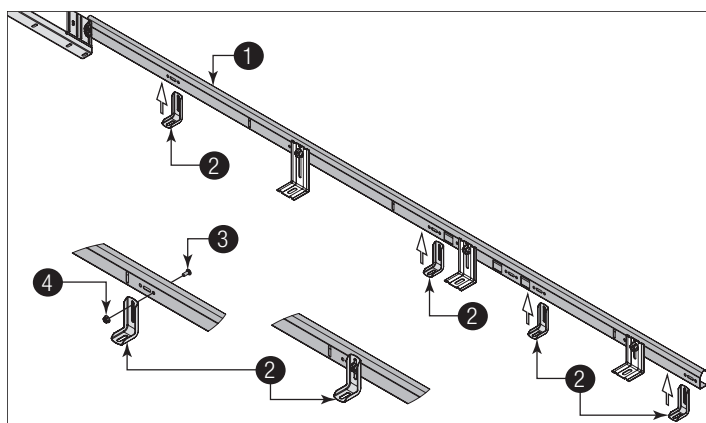

**Figure 13, Left Side Shown**

1	Vertical Tracks	3	1/4" - 20 x 9/16" Track Bolt
2	Windload Jamb Brackets	4	1/4" - 20 Flange Hex Nut

## 4 ATTACHING (WL) STRUT(S) TO SECTIONS

**NOTE:** Refer to Door Section Identification, located in the pre-installation section of this manual or refer to Package Contents. Refer to the Package Contents and or Breakdown of Parts to determine if your door came with struts.

### NOTICE

LARGER DOORS WILL HAVE COLOR CODED STRUTS. AN 18 GAUGE (.046) STRUT WILL HAVE RED ENDS OR A 20 GAUGE (.034) STRUT WILL HAVE BLUE ENDS.

4a. Reference the Strutting Schedule (shown on the Windload Specification Sheet included in the hardware box), determine the placement of the struts for your door height. Next, using sawhorses, lay the appropriate section on a flat smooth surface.

#### For The Bottom Section:

See Figure 14 and Figure 15 for the following steps.

4b. **If your doors windload option code begins with 06**, place the strut with the notched ends 1 over the bottom rib 2 of the bottom section 3 with the notches facing down. Center the strut left to right on the section surface. **If your doors windload option code begins with 02**, place the strut with the notched ends over the bottom rib of the bottom section with the notches facing down. The ends of the strut will fit in between the bottom corner bracket flanges 4. Center the strut left to right on the section surface.

4c. Fasten the strut at each ends through the top flange using (1) 1/4" - 14 x 7/8" self drilling screw 5. **If your door windload option code begins with 02**, then also fasten the strut at each ends to the bottom section rib using (2) 1/4" - 14 x 5/8" self tapping screws 6, through the two holes in the bottom corner bracket flanges.

4d. Place (2) 1/4" - 14 x 5/8" self tapping screws through each pre-punched hole at each center hinge locations 7.

4e. Place the strut 8 over the top rib of the bottom section 9 with the eight pre-punched holes, facing up 10. Center strut left to right on the section surface. Attach the strut at each ends through the struts bottom flange using (1) 1/4" - 14 x 7/8" self drilling screw 11.

4f. Finish securing the struts to the section using (2) 1/4" - 14 x 5/8" self tapping screws midway between the end of the door and the center hinge locations 12 and (1) 1/4" - 14 x 5/8" self tapping screw approximately eight inches from each end 13.

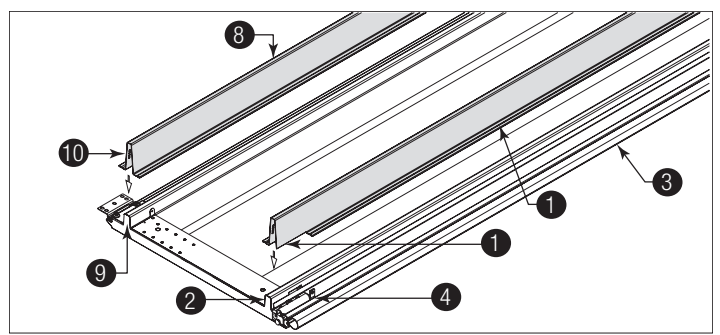

**Figure 14, Left Side Shown**

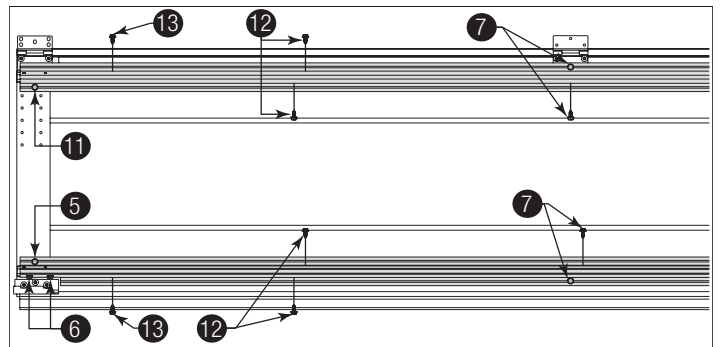

**Figure 15**

1	Strut With The Notched Ends	8	Strut
2	Bottom Rib	9	Top Rib Of The Bottom Section
3	Bottom Section	10	Eight Pre-Punched Holes, Facing Up
4	Bottom Corner Bracket Flanges	11	1/4" - 14 x 7/8" Self Drilling Screw
5	1/4" - 14 x 7/8" Self Drilling Screw	12	1/4" - 14 x 5/8" Self Tapping Screws
6	1/4" - 14 x 5/8" Self Tapping Screws	13	1/4" - 14 x 5/8" Self Tapping Screw
7	Center Hinge Locations		

#### For The Lock, Intermediate(s) And Top Sections:

See Figure 16 and Figure 17 for the following steps.

**NOTE:** There will be no factory attached end or center hinges at the top of the top sections.

4a. Place the strut 1 over the top rib 2 of each of the remaining sections 3 with the (8) pre-punched holes at the ends facing up 4. Center the strut left to right on the section surface.

4b. Fasten the strut(s) at each end through the top and bottom flanges using (2) 1/4" - 14 x 7/8" self drilling screws 5.

4c. Fasten the strut(s) using (2) 1/4" - 14 x 5/8" self tapping screws 6 through each center hinge(s) locations 7.

4d. Finish securing the strut(s) to the section using (2) 1/4" - 14 x 5/8" self tapping screws midway between the end of the door 8 and the center hinge locations and (1) 1/4" - 14 x 5/8" self tapping screw approximately eight inches from each end 9.

**For The Windload Option Code 0356:**

4a. Place the strut over the top rib of the bottom section. Center the strut left to right on the section surface. Fasten the strut at each end using (2) 1/4" - 14 x 5/8" self tapping screws, through the top and bottom flanges of the strut as well as (2) 1/4" - 14 x 5/8" self tapping screws at all center hinge locations and midway between center hinge locations and the end of the strut.

4b. Attach the strut to the top rib of the intermediate section for a four section high door and the top rib of the intermediate and intermediate II sections for a five section high door, in the same manner the strut was attached to the bottom section.

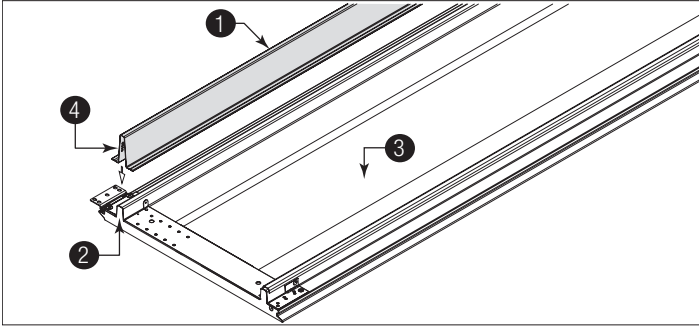

**Figure 16, Left Side Shown**

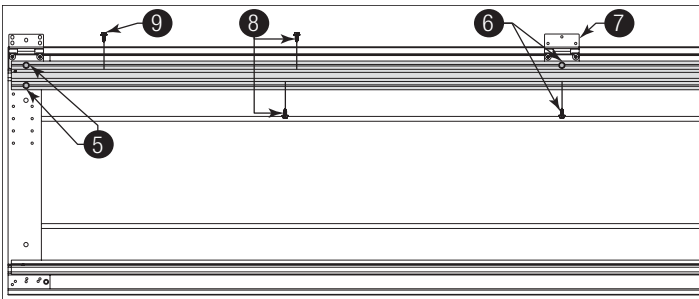

**Figure 17**

1	Strut	6	1/4" - 14 x 5/8" Self Tapping Screws
2	Top rib	7	Center Hinges Locations
3	Remaining Sections	8	1/4" - 14 x 5/8" Self Tapping Screws
4	(8) Pre-Punched Holes	9	1/4" - 14 x 5/8" Self Tapping Screw
5	(2) 1/4" - 14 x 7/8" Self Drilling Screws		

**5 ATTACHING REINFORCEMENT BRACKETS TO SECTION**

**NOTE:** Refer to your Windload Specification Sheet and install the reinforcement brackets onto your sections accordingly.

**See Figure 18 and Figure 19 for the following steps.**

5a. Starting on the left hand side of top section 1, position the top holes in the reinforcement bracket 2 over the strut 3 and the slot in the reinforcement bracket over the endcap 4 of the top section.

5b. Secure the reinforcement bracket to the strut and the end cap of the section using (4) 1/4" - 14 x 7/8" self drilling screws 5.

5c. Repeat same process for other side.

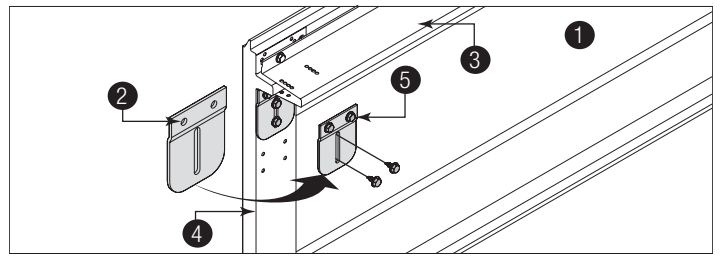

**Figure 18, Left Side Shown**

1	Top Section	4	End Cap
2	Reinforcement Bracket	5	(4) 1/4" - 14 x 7/8" Self Drilling Screws
3	Strut		

**If you have more than two reinforcement brackets:**

5d. At the center of the top section 1 position the top holes in the reinforcement bracket 2 over the strut 3 and the slot in the reinforcement bracket over the center stile 4 of the top section.

5e. Fasten the reinforcement bracket to the strut and the center stile of the top section using (4) 1/4" - 14 x 7/8" self drilling screws 5.

5f. Repeat same process for other sections.

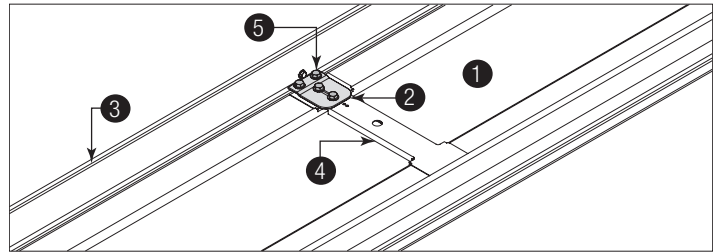

**Figure 19**

1	Top Section	4	Center Stile
2	Reinforcement Bracket	5	(4) 1/4" - 14 x 7/8" Self Drilling Screws
3	Strut		

**6 ATTACHING ROLLER SLIDES TO SECTION**

**NOTE:** Refer to door section identification, located in the pre-installation section of this manual or refer to Breakdown of Parts.

**See Figure 20 for the following steps.**

**NOTE:** Each roller slide 1 has a viewing hole 2. This will allow for correct positioning of the roller slide on the strut 3.

6a. Starting with the bottom section 4, place a roller slide on the top left side of the strut and align with the first set of holes 5 closest to the section. Attach the roller slide to the strut using (2) 1/4" - 14 x 5/8" self tapping screws 6.

6b. Repeat for opposite side.

Next, position and install roller slides onto the sections, as shown:

6c. For the Lock Section (Second Section), use the second set of holes 7.

6d. For the Intermediate Section I (Third Section), use the third set of holes 8.

6e. For the Intermediate Section II (Fourth Section (Only a five section high door will have a second intermediate section)), use the fourth set of holes 9.

# NOTICE

**DO NOT** INSTALL ROLLER SLIDES ONTO THE TOP SECTION.

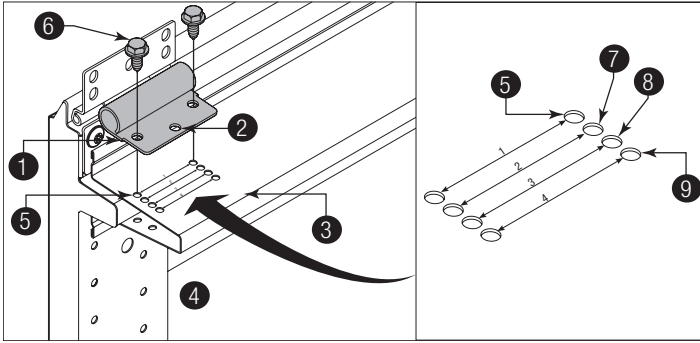

**Figure 20, Left Side Shown**

1	Roller Slide	6	(2) 1/4" - 14 x 5/8" Self Tapping Screw
2	Viewing Hole	7	Second Set Of Holes
3	Bottom Section	8	Third Set Of Holes
4	Strut	9	Fourth Set Of Holes
5	First Set Of Holes		

## 7 ATTACHING COUNTERBALANCE LIFT CABLES

**IMPORTANT:** Refer to door section identification, located in the pre-installation section of this manual or refer to Breakdown of Parts.

### ! WARNING

**ENSURE TIGHT FIT OF CABLE LOOP OVER MILFORD PIN TO PREVENT COUNTERBALANCE LIFT CABLE FROM COMING OFF THE PIN, WHICH COULD ALLOW THE DOOR TO FALL AND RESULT IN DEATH OR SERIOUS INJURY.**

**IMPORTANT:** Verify bottom weather seal (2) is aligned with bottom section (1). If there is more than 1/2" excess weather seal on either side, trim weather seal even with bottom section.

**See Figure 21 and Figure 22 for the following steps.**

7a. Uncoil (3) the counterbalance lift cables (4). Place the cable loop (5) on the milford pin (6) of the bottom corner bracket (7). Repeat this process for the opposite side.

7b. Insert a short stem track roller (8) into the bottom corner bracket and another into the roller slide (9) at the top of the bottom section.

**NOTE:** Larger doors will use long stem track rollers (10) with double graduated end hinges (11).

7c. Repeat this process for the opposite side.

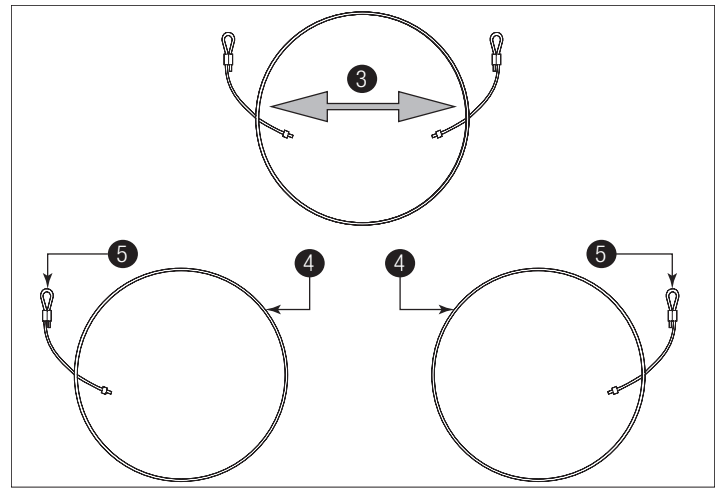

**Figure 21, Left and Right Hand Drums Shown**

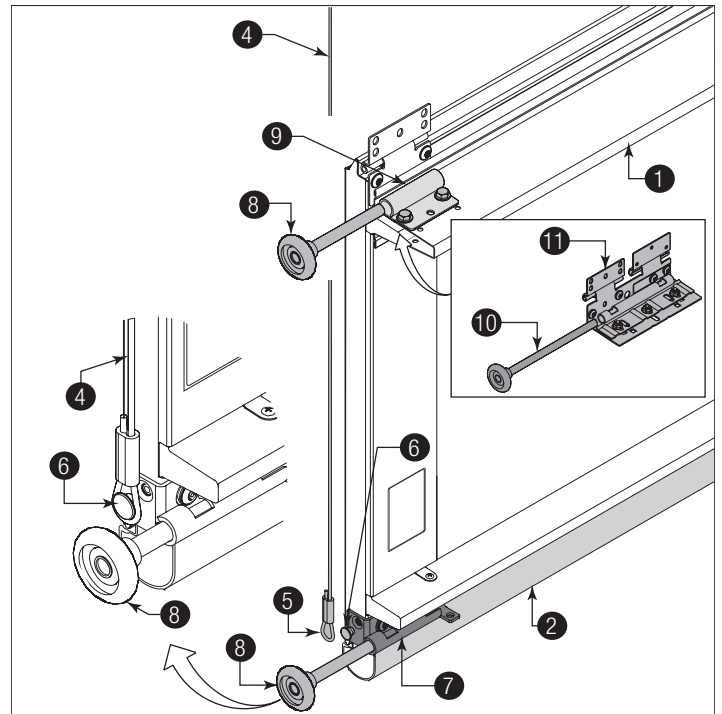

**Figure 22, Left Side Shown**

1	Bottom Section	7	Bottom Corner Bracket
2	Bottom Weather Seal	8	Short Stem Track Roller
3	Uncoil	9	Roller Slide
4	Counterbalance Lift Cable	10	Long Stem Track Rollers
5	Cable Loop	11	Double Graduated End Hinges
6	Milford Pin		

## 8 POSITIONING BOTTOM SECTION

See Figure 23 for the following steps.

8a. Center the bottom section 1 in the door opening.

8b. Use a level 2 and wood shims 3 (if necessary) to level the bottom section. When the bottom section is leveled, temporarily hold it in place by driving a nail into the jamb and bending it over the edge of the bottom section on both sides.

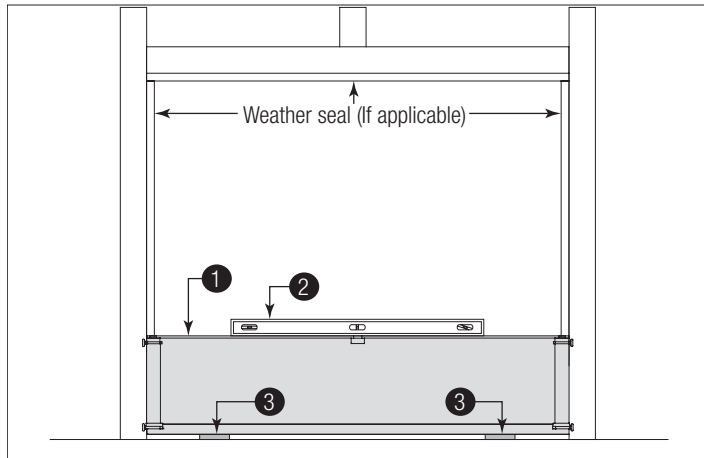

Figure 23

1	Bottom Section	3	Wood Shims
2	Level		

## 9 ATTACHING VERTICAL TRACKS TO JAMBS

**IMPORTANT:** Depending on your door, you may have Quick Install Flag Angles, Fully Adjustable Flag Angles, Riveted Vertical Track Assemblies or you may have Angle Mount Vertical Track Assemblies. Refer to Package Contents / Breakdown of Parts, to determine which Flag Angles / Vertical Track Assemblies you have.

**IMPORTANT:** If this door is to be installed prior to a finishing construction of the building's floor, the vertical tracks and the door bottom section assembly should be installed such that when the floor is constructed, no door or track parts are trapped in the floor construction.

**IMPORTANT:** If the bottom section was leveled with shims, the vertical track on the shimmed side must be raised the same height as the shim. Recheck the top of the vertical tracks to be level from side to side.

**IMPORTANT:** Make sure the counterbalance lift cable is located between the track rollers and the door jamb.

See Figure 24 through Figure 26 for the following steps.

9a. Starting on the left hand side of the bottom section 1, remove the nail. Position the left hand vertical track assembly 2 over the track rollers of the bottom section and install, as shown. Drill 3/16" pilot holes into the door jamb for the lag screws.

**IMPORTANT:** For proper flag angle lag screw location, note the flag angle styles 3.

**For Doors With Quick Install Flag Angle or Fully Adjustable Flag Angles:**

9b. Loosely fasten jamb brackets 4 and flag angle 5 to the jamb using 5/16" x 1-5/8" lag screws 6.

9c. Tighten lag screws, securing the bottom jamb bracket to jamb, maintain 3/8" to 5/8" spacing 7, between the bottom section and vertical track.

9d. Hang counterbalance lift cable over flag angle. Repeat same process for other side.

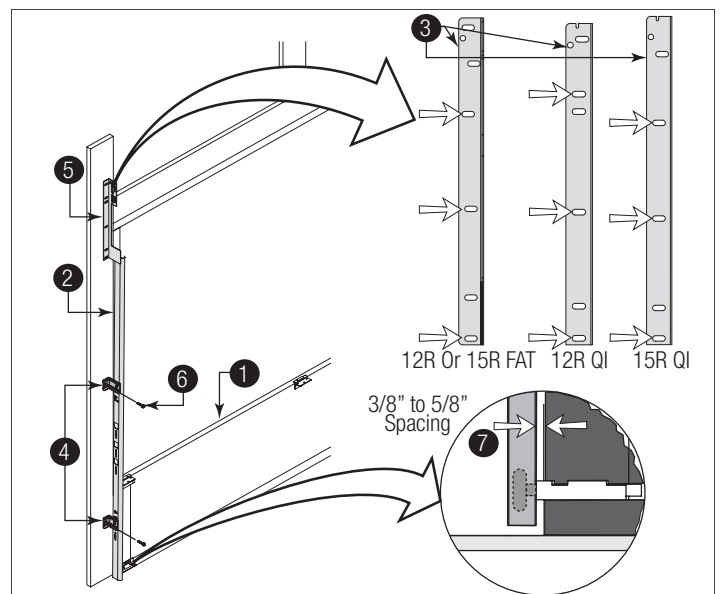

Figure 24, Left Side Shown

**For Doors With Riveted Vertical Track Assemblies:**

9b. Loosely fasten jamb brackets 4 and flag angle 5 to the jamb using 5/16" x 1-5/8" lag screws 6.

9c. Tighten lag screws, securing the bottom jamb bracket to jamb, maintain 3/8" to 5/8" spacing 7 as shown, between the bottom section and vertical track.

9d. Hang counterbalance lift cable over flag angle. Repeat same process for other side.

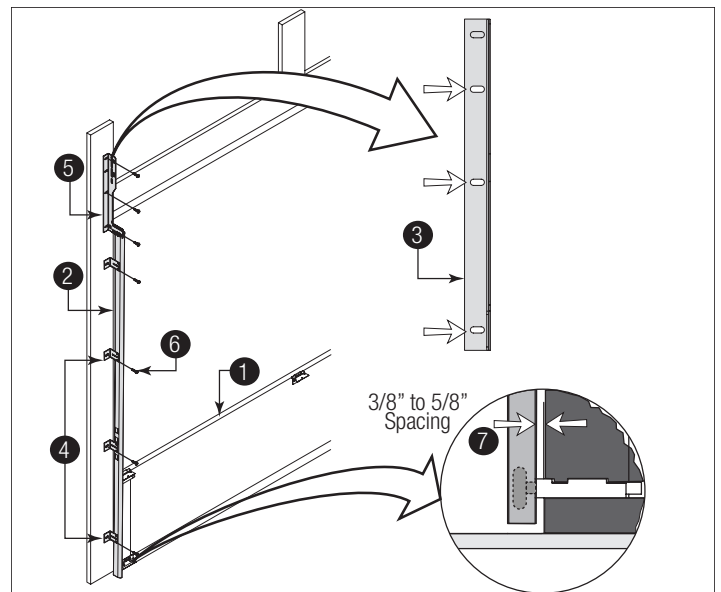

Figure 25, Left Side Shown

1	Bottom Section	5	Flag Angle
2	Vertical Track Assembly	6	5/16" x 1-5/8" Lag Screws
3	Flag Angle Styles	7	3/8" to 5/8" Spacing
4	Jamb Brackets		

**For Doors With Angle Mount Vertical Track Assemblies:**

9b. Loosely fasten the slots 2 in the angle mount 3 to the jamb using 5/16" x 1-5/8" lag screws 4.

9c. Tighten lag screws, securing the bottom slot 5 in the angle mount, maintain 3/8" to 5/8" spacing 6 as shown, between the bottom section and vertical track.



9d. Hang counterbalance lift cable over angle mount. Repeat same process for other side.

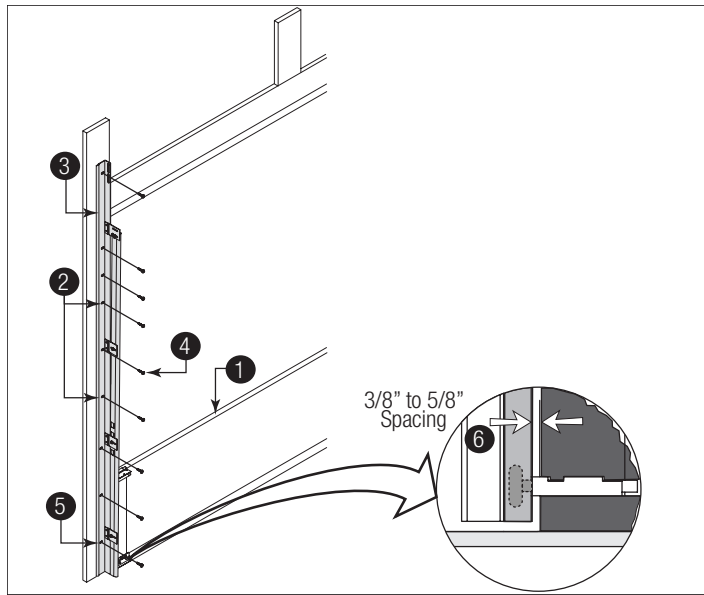

Figure 26, Left Side Shown

1	Bottom Section	4	5/16" x 1-5/8" Lag Screws
2	Slots	5	Bottom Slot
3	Angle Mount	6	3/8" to 5/8" Spacing

**IMPORTANT:** Push and hold the hinge leaf securely against the sections while securing with 1/4" - 14 x 5/8" self tapping screws. Ensure there is no gap between the hinge leaves and the sections.

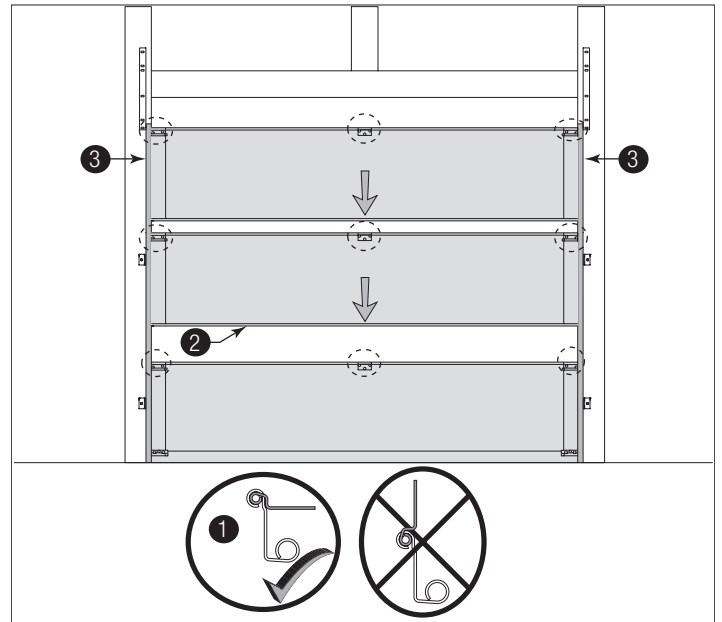

Figure 27, Stacking Sections

1	Hinge Flipped Down Position	3	Vertical Tracks
2	Second Section (Lock Section)		

## 10 STACKING SECTIONS

**NOTE:** The sections can be identified by the roller slides that were previously installed, reference Step Attaching Roller Slides To Section. The smallest roller slide attached to the strut of the section should be stacked on top of the bottom section, with each roller slide increasing as the sections are stacked. Refer to door section identification, located in the pre-installation section of this manual or refer to Breakdown of Parts.

### NOTICE

BEFORE STACKING SECTIONS, MAKE SURE GRADUATED END AND CENTER HINGES ARE FLIPPED DOWN ① TO AVOID POSSIBLE DAMAGE TO YOUR DOOR, WHEN STACKING ANOTHER SECTION ON TOP.

### NOTICE

LARGER DOORS WILL USE LONG STEM TRACK ROLLERS WITH DOUBLE GRADUATED END HINGES.

See Figure 27 and Figure 28 for the following steps.

10a. Install track rollers into graduated end hinges of remaining sections.

10b. With a helper, lift second section ② and guide the track rollers into the vertical tracks ③. Lower section until it is seated against bottom section.

10c. Flip hinges up ④. Fasten center hinge(s) ⑤ with 1/4" - 14 x 5/8" self tapping screws ⑥. Repeat for end hinges ⑦ ⑧ ⑨ ⑩ and center hinge(s).

**IMPORTANT:** To prevent center hinge leaf from rotating, secure the top middle hole of the center hinge leaf with one 1/4" - 14 x 5/8" self-tapping screw then secure the other two holes.

**IMPORTANT:** Larger doors with double graduated end hinges, fasten both hinges to connect the sections using 1/4" - 14 x 5/8" self-tapping screws.

10d. Repeat same process for the other sections, except top section.

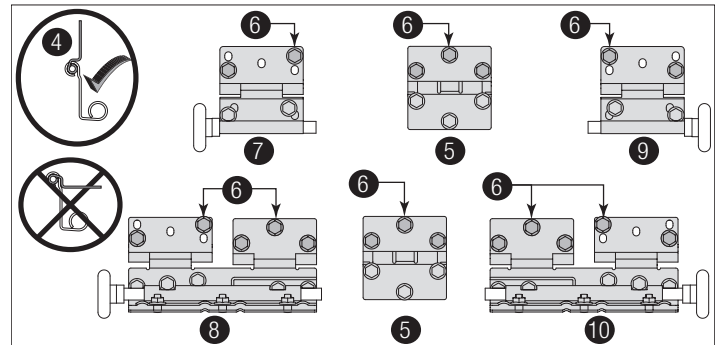

Figure 28, Hinges after Stacking Sections

4	Hinge Flipped Up Position	8	Left Double Graduated End Hinge with Long Stem Track Roller
5	Center Hinge(s)	9	Right Graduated End Hinge with Short Stem Track Roller
6	1/4" - 14 x 5/8" Self Tapping Screw Locations	10	Right Double Graduated End Hinge with Long Stem Track Roller
7	Left Graduated End Hinge with Short Stem Track Roller		

## 11 ATTACHING TOP FIXTURES TO TOP SECTION

**NOTE:** Depending on your door, you may have Top Fixture Bases and Top Fixture Slides or you may have Top Fixture Roller Slides. Refer to Package Contents / Breakdown of Parts, to determine which Top Fixtures you have.

See Figure 29 and Figure 30 for the following steps.

### If You Have Top Fixture Bases And Top Fixture Slides:

11a. Align the top holes in the top fixture base ① with the second set of holes in the end cap ② of the top section.

11b. Fasten to section using four 1/4" - 14 x 5/8" self tapping screws ③.

11c. Secure the top fixture slide ④ to the fixture base loosely using two 1/4" - 14 x 5/8" carriage bolts ⑤ and two 1/4" - 20 flange hex nuts ⑥. Insert short stem track roller ⑦ into top fixture slide.

11d. Repeat the process for the opposite side.

**NOTE:** The top fixture slide will be tightened and adjusted later, in "Adjusting Top Fixtures" step.

**IMPORTANT:** Ensure the top fixture slide is able to slide along the top fixture base. If needed, loosen the 1/4" - 20 flange hex nuts.

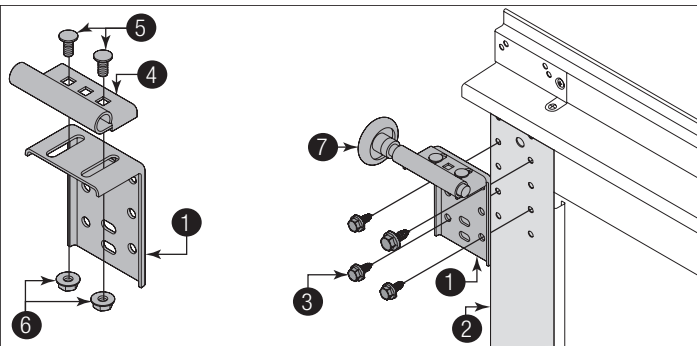

Figure 29, Left Side Shown

1	Top Fixture Base	5	1/4" - 14 x 5/8" Carriage Bolt (Qty 2)
2	End Cap	6	1/4" - 20 Flange Hex Nut (Qty 2)
3	1/4" - 14 x 5/8" Self Tapping Screw (Qty 8)	7	Short Stem Track Roller
4	Top Fixture Slide		

### If You Have Top Fixture Roller Slides:

11a. Starting on the left hand side of the top section, align the slots in the top fixture roller slide ① with the set of holes on the bottom of the strut ②.

11b. Loosely fasten top fixture roller slide to the strut using (2) 1/4" - 14 x 5/8" self tapping screws ③.

11c. Insert short stem track roller into top fixture roller slide ④.

11d. Repeat the same process for the right hand side.

**NOTE:** The top fixture roller slide will be tightened and adjusted later, in step, Adjusting Top Fixture.

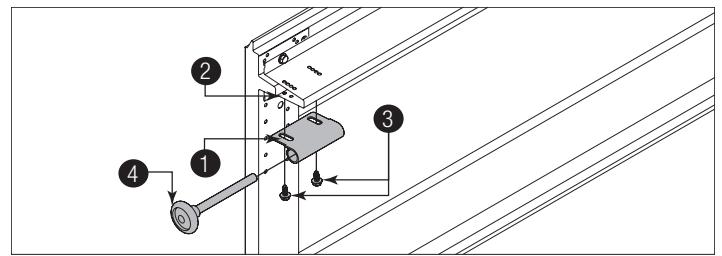

Figure 30, Left Side Shown

1	Slots In The Top Fixture Roller Slide	3	1/4" - 14 x 5/8" Self Tapping Screw (Qty 4)
2	Bottom Of The Strut	4	Short Stem Track Roller

## 12 ATTACHING DRAWBAR OPERATOR BRACKET

**IMPORTANT:** If installing a drawbar operator (motor operated), the drawbar operator bracket must be mounted and secured prior to installing top section.

### NOTICE

TO AVOID POSSIBLE DAMAGE TO YOUR DOOR, THE TOP SECTION SHOULD BE REINFORCED WITH A STRUT ④.

### NOTICE

WHEN CONNECTING A DRAWBAR OPERATOR TYPE GARAGE DOOR OPENER TO THIS DOOR, A WAYNE DALTON DRAWBAR OPERATOR BRACKET MUST BE SECURELY ATTACHED TO THE TOP SECTION OF THE DOOR, ALONG WITH ANY STRUT PROVIDED WITH THE DOOR.

**IMPORTANT:** When attaching drawbar operator bracket to top section with strut ④, apply additional pressure to thread into the strut.

See Figure 31 and Figure 32 for the following steps.

12a. Prior to installing the top section ①, locate the center ② of the top section and seat the drawbar operator bracket ⑥ on top of the top section.

For retrofit applications, the drawbar operator bracket must be aligned with an existing drawbar operator.

12b. Install two #12 x 1/2" phillips head screws ⑧ on the back side of drawbar operator bracket ⑤. Clamp drawbar operator bracket to strut with vise clamps.

12c. Attach six 1/4" - 14 x 5/8" self-tapping screws ⑦ to the drawbar operator bracket. Remove vise clamps.

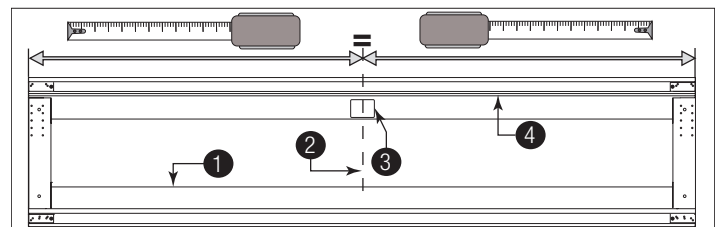
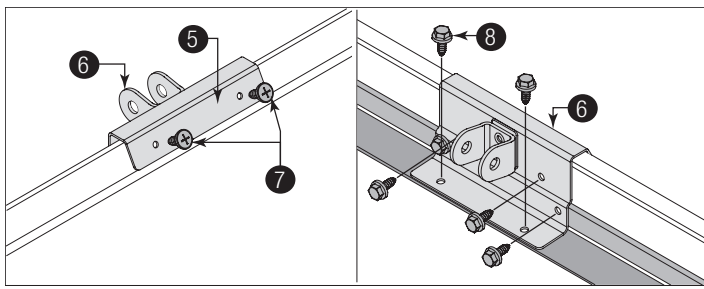
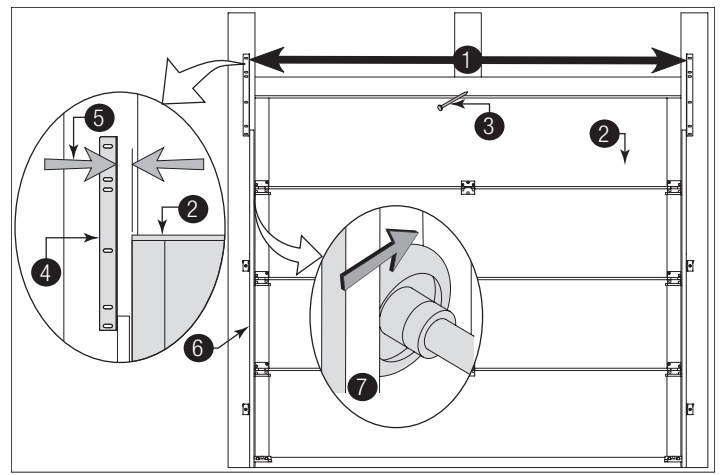

Figure 31



**Figure 32, Top Section and Drawbar Operator Bracket**

1	Top Section	5	Backside View of Drawbar Operator Bracket
2	Center Line	6	Drawbar Operator Bracket
3	Warning Label	7	#12 x 1/2" Phillips Head Screws (Qty 2)
4	Strut	8	1/4" - 14 x 5/8" Self-Tapping Screws (Qty 6)



**Figure 33**

1	Clearance Measurement Between Both Flag Angles	4	Flag Angle Or Angle Mount
2	Top Section	5	Clearance Measurement Between Flag Angle and Door Edge
3	Nail	6	Vertical Track Against Track Rollers

## 13 STACKING TOP SECTION

**IMPORTANT:** The dimension between the flag angles or angle mounts (1) must be door width plus 3-3/8" - 3-1/2" (86 mm- 89 mm).

See Figure 33 for the following steps.

13a. Place the top section (2) in the opening, on top of the section stacked.

13b. Install a nail (3) to temporarily hold the top section.

13c. Flip up the hinge leaves, hold tight against section, and fasten center hinges first and end hinges last (see Stacking Sections).

13d. Position flag angle or angle mount (4) between 1-11/16" to 1-3/4" (43 mm - 44 mm) from the edge of the door (5), then tighten the bottom lag screw. Flag angles or angle mount must be parallel to the door sections. Repeat for other side.

13e. Complete the vertical track (6) installation.

**If you have quick install track:** Secure the jamb brackets and tightening the other lag screws. Repeat for other side.

**If you have fully adjustable track or riveted track:** Secure the jamb bracket(s) and tightening the other lag screws. Push the vertical track against the track rollers so that the track rollers are touching the deepest part of the curved side of the track; tighten all the track bolts and nuts. Repeat for other side.

**If you have Angle Mount Track:** Complete the vertical track installation by tightening the other lag screws. Push the vertical track against the track rollers so that the track rollers are touching the deepest part of the curved side of the vertical track. Repeat for other side.

## 14 ATTACHING HORIZONTAL TRACKS

**NOTE:** Depending on your door, you may have Quick Install Flag Angles, Fully Adjustable Flag Angles, Riveted Vertical Track Assemblies or you may have Angle Mount Vertical Track Assemblies. Refer to Package Contents / Breakdown of Parts, to determine which Flag Angles / Vertical Track Assemblies you have.

### ! WARNING

**DO NOT RAISE DOOR UNTIL HORIZONTAL TRACKS ARE SECURED AT REAR, AS OUTLINED IN STEP 21, ATTACHING REAR BACK HANGS. THE REAR BACK HANGS OR DOOR COULD FALL FROM OVERHEAD POSITION CAUSING DEATH OR SERIOUS INJURY.**

**If You Have Quick Install Flag Angles:**

See Figure 34 for the following steps.

14a. Place the curved end of the horizontal track (1) over the top track roller of the top section.

14b. Align key slot of the horizontal track with the Quick Install tab (2) of the flag angle (3). Push curved portion of horizontal track down to lock tab in place (4).

14c. Level (5) the horizontal track assembly and bolt the horizontal track angle (8) to the first encountered slot in the flag angle using one 3/8" - 16 x 3/4" truss-head bolt (7) and one 3/8" - 16 hex nut (6).

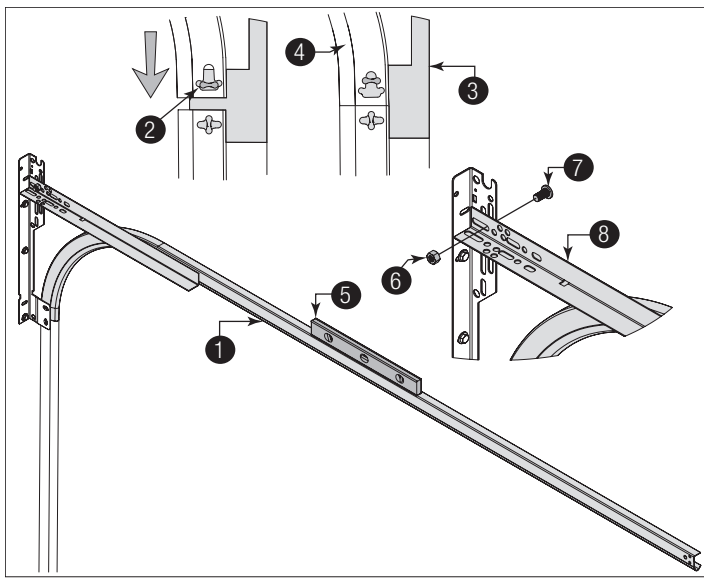

**Figure 34, Left Side Shown**

1	Horizontal Track	5	Level
2	Quick Install Tab	6	3/8" - 16 Hex Nut
3	Flag Angle	7	3/8" - 16 x 3/4" Truss-Head Bolt
4	Quick Install Tab in Locked Position	8	Horizontal Track Angle

**For Other Flag Angles:**

**See Figure 35 for the following steps.**

14a. Place the curved end of the horizontal track (1) over the top track roller of the top section.

14b. Attach the horizontal track to the flag angle (2) with two 1/4" - 20 x 9/16" track bolts (3) and two 1/4" - 20 flange hex nuts (4).

14c. Level (7) the horizontal track assembly and bolt the horizontal track angle (8) to the first encountered slot in the flag angle using one 3/8" - 16 x 3/4" truss-head bolt (5) and one 3/8" - 16 hex nut (6). Repeat for right side.

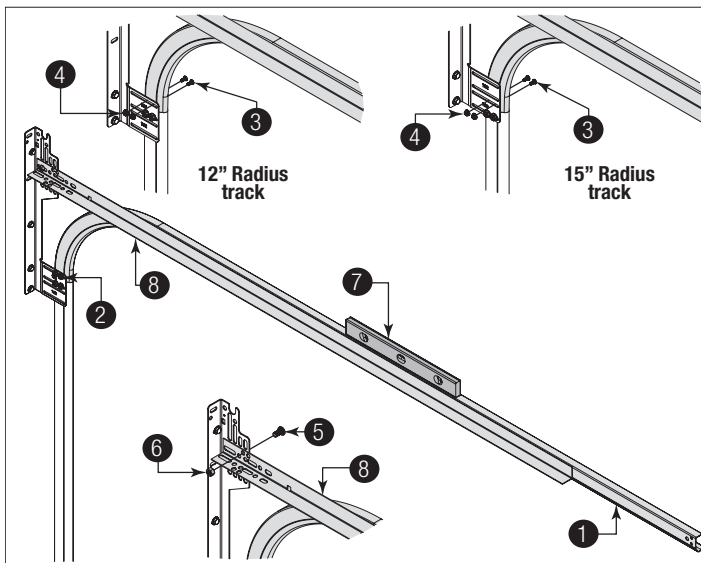

**Figure 35, Left Side Shown**

1	Horizontal Track	5	3/8" - 16 x 3/4" Truss-Head Bolt
2	Flag Angle Upper Slot	6	3/8" - 16 Hex Nut
3	1/4" - 20 x 9/16" Track Bolts	7	Level
4	1/4" - 20 Flange Hex Nuts	8	Horizontal Track Angle

**If you have Angle Mount Track:**

**See Figure 36 for the following steps.**

14a. Place the curved end of the horizontal track (1) over the top track roller of the top section.

14b. Attach the horizontal track to the angle mount (2) with two 1/4" - 20 x 9/16" track bolts (3) and two 1/4" - 20 flange hex nuts (4).

14c. Level (7) the horizontal track assembly and bolt the horizontal track angle (8) to the first encountered slot in the angle mount using one 3/8" - 16 x 3/4" truss-head bolt (5) and one 3/8" - 16 hex nut (6). Repeat for right side.

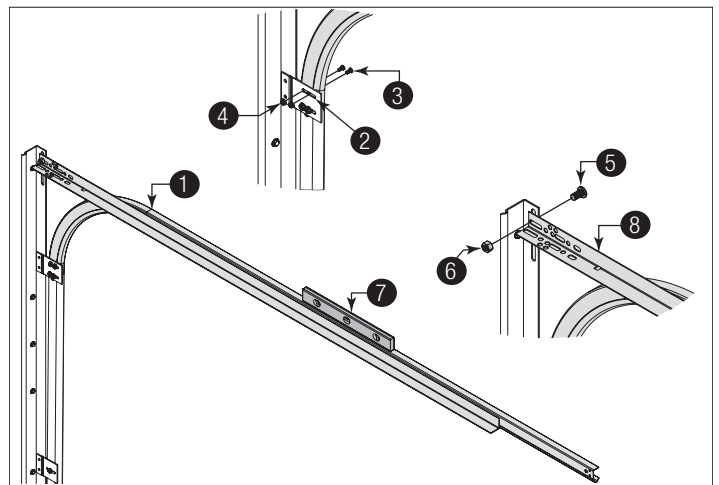

**Figure 36, Left Side Shown**

1	Horizontal Track	5	3/8" - 16 x 3/4" Truss-Head Bolt
2	Angle Mount	6	3/8" - 16 Hex Nut
3	1/4" - 20 x 9/16" Track Bolts	7	Level
4	1/4" - 20 Flange Hex Nuts	8	Horizontal Track Angle

14d. When complete, remove the nail that was holding the top section in position.

**NOTICE**

FAILURE TO REMOVE NAIL BEFORE ATTEMPTING TO RAISE DOOR COULD CAUSE PERMANENT DAMAGE TO TOP SECTION.

## 15 ADJUSTING TOP FIXTURES

**NOTE:** Depending on your door, you may have Top Fixture Bases and Top Fixture Slides or you may have Top fixture roller slides. Refer to Package Contents / Breakdown of Parts, to determine which Top Fixtures you have.

**If You Have Top Fixture Bases And Top Fixture Slides:**

See Figure 37 for the following steps.

15a. Vertically align the top section ① of the door with the lower sections. Position the top fixture slide ② with a track roller ⑤ against the horizontal track ⑥.

15b. Maintaining the position of the slide, tighten the two 1/4" - 20 flange hex nuts ③ to secure the top fixture slide to the top fixture base ④.

15c. Repeat for the right side.

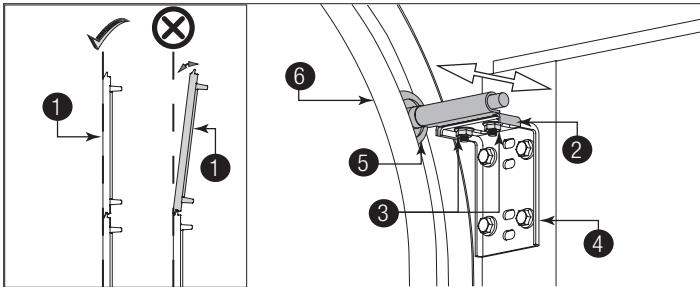

Figure 37, Left Side Shown

1	Door Top Section	4	Top Fixture Base
2	Top Fixture Slide	5	Track Roller
3	1/4" - 20 Flange Hex Nuts	6	Horizontal Track

**If You Have Top Fixture Roller Slides:**

See Figure 38 for the following steps.

15a. Vertically align the top section ① of the door with the lower sections. Position the top fixture roller slide ②, out against the horizontal track ③.

15b. Maintaining the top fixture roller slide position, tighten the (2) 1/4" - 14 x 5/8" self tapping screws ④ to secure the top fixture roller slide to the strut ⑤ of the top section.

15c. Repeat for right side.

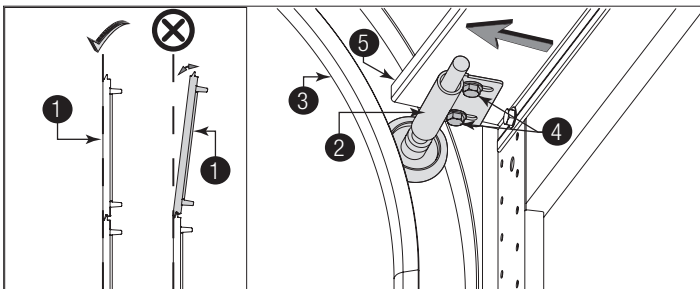

Figure 38, Left Side Shown

1	Top Section	4	(2) 1/4" - 14 x 5/8" Self Tapping Screws
2	Top Fixture Roller Slide	5	Strut
3	Horizontal Track		

## Counterbalance Installation Instructions

### 16 ATTACHING END BEARING BRACKETS

**NOTE:** Refer to Package Contents or Breakdown Of Parts, to determine which type of end bearing bracket ① you received.

**IMPORTANT:** Measure the radius of your horizontal track to determine if your horizontal track ③ is 12" or 15" Radius. The end bearing bracket's lower slots ④ are used on doors with 12" radius track, the upper slots ⑤ are used on doors with 15" radius track.

**IMPORTANT:** Drill 3/16" pilot holes into the door jamb for the lag screws.

**NOTE:** End bearing brackets are right and left hand.

See Figure 39 through Figure 41 for the following steps.

16a. Attach the left hand end bearing bracket to the left hand flag angle ② (For J3. Bracket) or through the end bearing bracket's upper / lower slots to the left hand horizontal track angle ⑥ (For J4. Bracket) using two 3/8" - 16 x 3/4" truss head bolts ⑦ and two 3/8" - 16 hex nuts ⑧.

16b. Secure the top of the end bearing bracket to the jamb ⑨ using 5/16" x 1-5/8" lag screw(s) ⑩.

16c. Repeat the same process for right hand side.

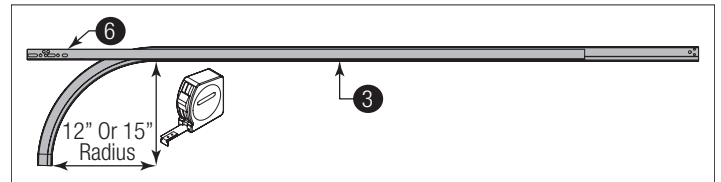

Figure 39

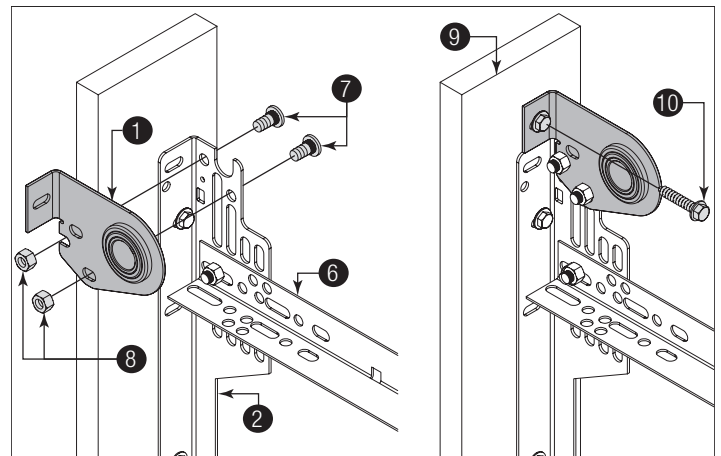

Figure 40, Left Side Shown (For J3. Bracket)

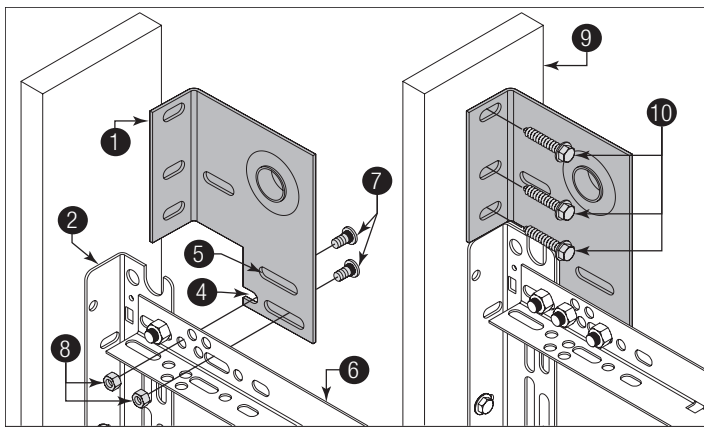

Figure 41, Left Side Shown (For J4. Bracket)

1	End Bearing Bracket	6	Horizontal Track Angle
2	Flag Angle	7	3/8" - 16 x 3/4" Truss Head Bolts
3	Horizontal Track	8	3/8" - 16 Hex Nuts
4	Lower Slots	9	Jamb
5	Upper Slots	10	5/16" x 1-5/8" Lag Screw(s)

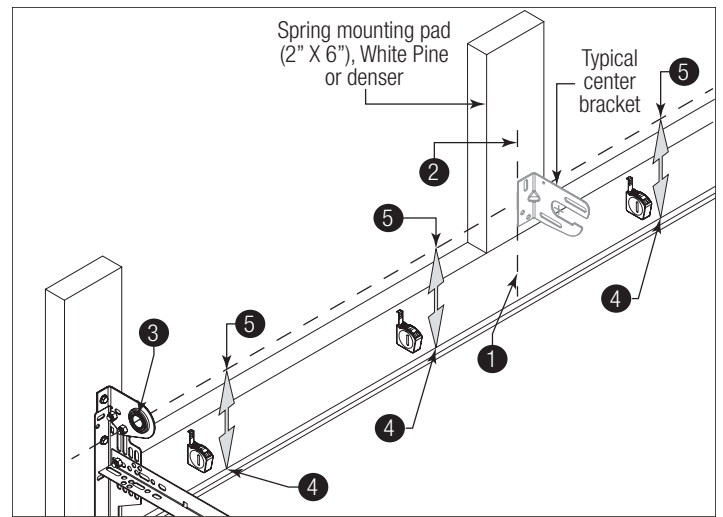

Figure 42, Left Side Shown

1	Center Of The Door	4	Top Of Door
2	Vertical Line	5	Horizontal Line
3	End Bearing Brackets		

See Figure 43 for the following steps.

**If your door did not come with a center coupler assembly or Torsion Springs less than 3-3/4" ID:**

17e. Mark a vertical pencil line ① on the mounting surface above the door, at the center.

17f. Align the edge of the center bracket ② with the vertical pencil line and the center of the center bracket with the horizontal pencil line ③; this is to ensure the torsion shaft is level between the center and end bearing brackets.

**NOTE:** On some single spring doors, the spring can be longer than half the opening width. If your spring is longer, then the center bracket must be mounted off center for the spring to fit properly. Measure spring length adding room for spring growth during winding, to determine appropriate center bracket location.

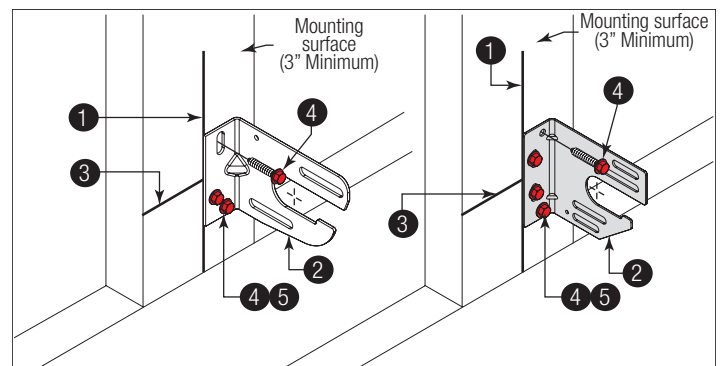

Figure 43

1	Vertical Line	3	Horizontal Line
2	Center Bracket		

See Figure 44 for the following steps.

**If your door did come with a center coupler assembly or 3-3/4" ID Torsion Springs:**

17e. Mark a vertical pencil line ① on the mounting surface above the door, at the center.

17f. Split the difference up and position the (2) center bearing brackets ② apart from each other.

## 17 ATTACHING CENTER BRACKET TO WALL

**NOTE:** Refer to Package Contents / Breakdown of Parts, to determine which Center Bracket(s) came with your door.

### WARNING

**MAKE SURE THE CENTER BRACKET IS SECURELY INSTALLED ONTO THE HEADER. FAILURE TO DO SO, COULD RESULT IN DEATH OR SERIOUS INJURY.**

**IMPORTANT:** Drill 3/16" pilot holes into header for the lag screws.

**NOTE:** Refer to Package Contents / Breakdown of Parts, to determine if your door came with a coupler assembly. If your door came with a coupler assembly, the mounting surface needs to be a minimum of 17" wide. The two center bearing brackets will need to be spaced 12" to 14" apart at the center of the door, as shown.

**NOTE:** If your door came with (4) springs, each of the outer springs mounting surface will need to be a minimum of 3" wide.

**NOTE:** If needed, measure the diameter of your springs. If you have a one piece shaft with 3-3/4" diameter springs, they do not share center brackets and do not have a coupler assembly.

See Figure 42 for the following steps.

17a. First, locate the center of the door ①.

17b. Mark a vertical pencil line ② on the mounting surface above the door, at the center.

17c. Measure from the center of the bearing, in one of the end bearing brackets ③, downwards, to the top of door ④.

17d. Using that measurement, measure that distance upwards from the top of the door to the mounting surface and mark a horizontal pencil line ⑤ which intersects the vertical pencil line.

17g. Mark two vertical pencil lines, one for each center bearing bracket onto the mounting surface above the door.

**NOTE:** If your door came with a center coupler assembly or if it utilizes 3-3/4" springs, the springs will not share a center bracket.

**NOTE:** If your door has (4) springs, split the distance between the center of the door and the end bracket on each side to locate the intermediate center brackets.

17h. Attach each of the center bracket(s) to the mounting surface, using 5/16" RED HEAD lag screws ③, as shown.

**IMPORTANT:** Use a 5/16" x 2-1/2" RED HEAD lag screw ④ instead of the 5/16" x 1-5/8" RED HEAD lag screw if mounting surface is covered by drywall. The lag screw must be attached through the bottom hole ⑤ of the center bracket(s). If mounting surface is a 2" x 6" board installed on top of masonry, drill a clearance hole in masonry for the 5/16" x 2-1/2" RED HEAD lag screws.

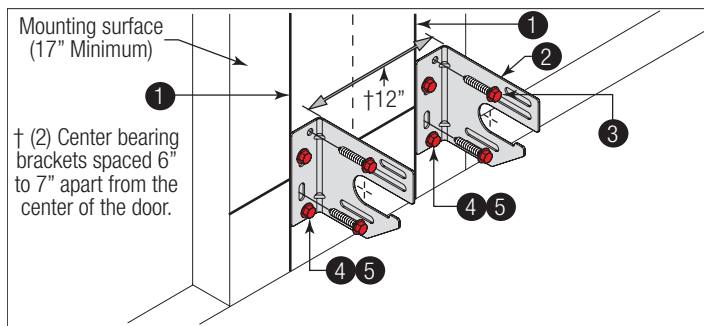

Figure 44

1	Vertical Line	4	5/16" x 2-1/2" RED HEAD lag screw
2	Center Bearing Brackets	5	Bottom Hole
3	5/16" RED HEAD Lag Screws		

## 18 TORSION SPRING ASSEMBLY

**NOTE:** Refer to the Package Contents and or Breakdown of Parts to determine if your door came with a coupler assembly.

**IMPORTANT:** Right and left hand is always determined from inside the building looking out.

**IMPORTANT:** Identify the torsion springs provided as either right wound (red winding cone) ①, which goes on the LEFT HAND SIDE or left wound (black winding cone) ②, which goes on the RIGHT HAND SIDE.

**IMPORTANT:** On single spring applications, only a left wound (black winding cone), is required.

**NOTE:** The set screws used on all winding cones and cable drums are colored red. DO NOT identify right and left hand by the set screw color.

See Figure 45 and Figure 46 for the following steps.

**IF YOU DON'T HAVE A COUPLER ASSEMBLY:**

18a. Facing the inside of the door, lay the torsion shaft / torsion keyed shaft ③ on the floor. Lay the torsion spring with the black winding cone and the black cable drum ④ at the right end of the torsion shaft / torsion keyed shaft. Lay the torsion spring with the red winding cone and the red cable drum ⑤ at the left end of the torsion shaft / torsion keyed shaft. Slide the center bracket bearing ⑥ onto the torsion shaft / torsion keyed shaft followed by the torsion springs and cable drums.

**IMPORTANT:** The center bracket bearing, torsion springs, and cable drums must be positioned, as shown.

18b. With assistance, pick up the torsion spring assembly and slide one end of the torsion shaft / torsion keyed shaft through one end bearing bracket ⑦.

18c. Lay the middle of the torsion shaft / torsion keyed shaft into the center bracket ⑧.

18d. Slide the other end of the torsion shaft / torsion keyed shaft into the other end bearing bracket ⑨.

18e. Position the torsion shaft so that equal amounts ⑩ of the shaft extend from each end bearing bracket.

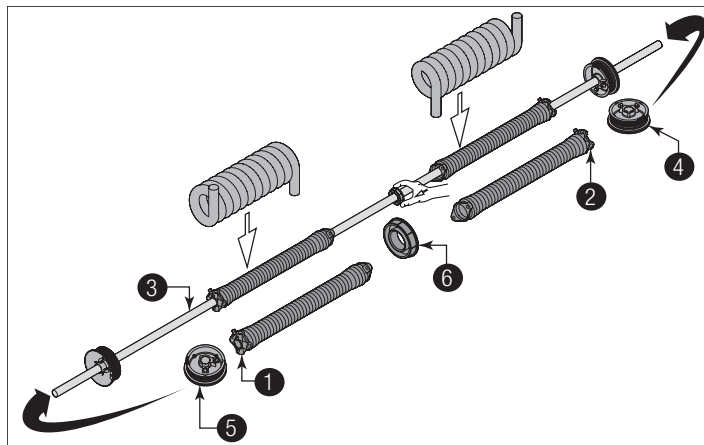

Figure 45

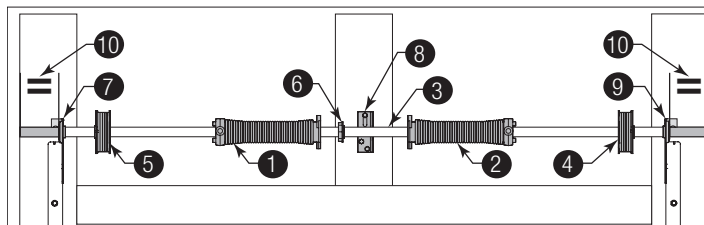

Figure 46

1	Red Winding Cone	6	Center Bracket Bearing
2	Black Winding Cone	7	End Bearing Bracket
3	Torsion Shaft / Torsion Keyed Shaft	8	Center Bracket
4	Black Cable Drum	9	End Bearing Bracket
5	Red Cable Drum	10	Equal Amounts

See Figure 47 through Figure 51 for the following steps.

**IF YOU HAVE A COUPLER ASSEMBLY:**

18a. Disassemble the coupler assembly ⑪ by removing the (3) 3/8" - 16 x 1-1/2" hex head screws ⑫, (6) 3/8" washers ⑬, (3) 3/8" lock washers ⑭ and the (3) 3/8" - 16 hex nuts ⑮ from the coupler halves ⑯.

18b. Loosen the set screws ⑰.

18c. Set the components aside.

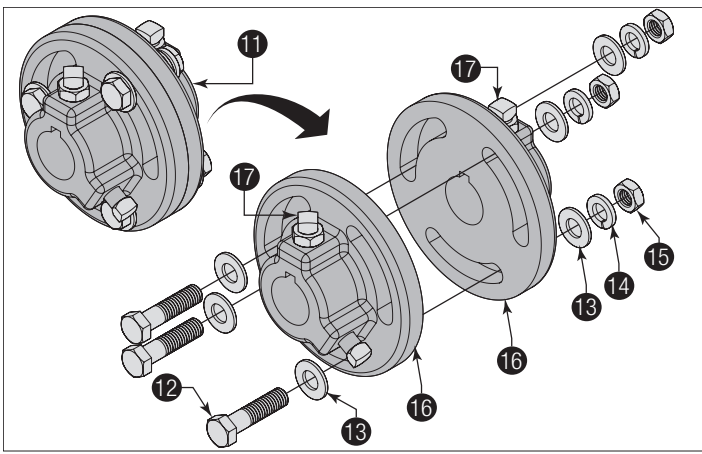

Figure 47

11	Coupler Assembly	15	3/8" - 16 Hex Nuts
12	3/8" - 16 x 1-1/2" Hex Head Screws	16	Coupler Halves
13	3/8" Washers	17	Set Screws
14	3/8" Lock Washers		

18d. Facing the inside of the door, lay the (2) torsion keyed shafts (3) on the floor. One torsion keyed shaft on the left hand side and the other torsion keyed shaft on the right hand side. Starting on the left hand side, lay one of the coupler halves, the center bracket bearing (6), torsion spring with the red winding cone (1) and the red cable drum (5) at the left end of the torsion keyed shaft. Next on the right hand side, lay the other coupler half, center bracket bearing, the torsion spring with the black winding cone (2), and the black cable drum (4) at the right end of the torsion keyed shaft. Slide the coupler halves (16), center bracket bearings onto the torsion keyed shafts followed by the torsion springs and the cable drums, as shown.

**IMPORTANT:** The coupler halves, center bracket bearings, torsion springs, cable drums must be positioned, as shown.

18e. Slide the flat edge of the couple half flush with the side edge of the torsion keyed shaft. Insert (1) key (18) into the slot of both the coupler half and the slot in the torsion keyed shaft. Tighten the (2) set screws (17) and the locking nut (19) to secure the coupler shaft to the torsion keyed shaft, as shown.

**NOTE:** Tighten the set screws to 14-15 ft-lbs (Once set screws contact the shaft, tighten screws an additional 1/2 turn).

18f. Repeat the same process for the other coupler half.

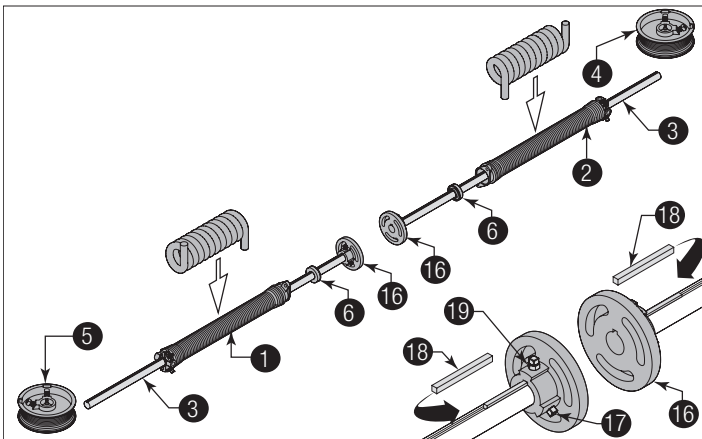

Figure 48

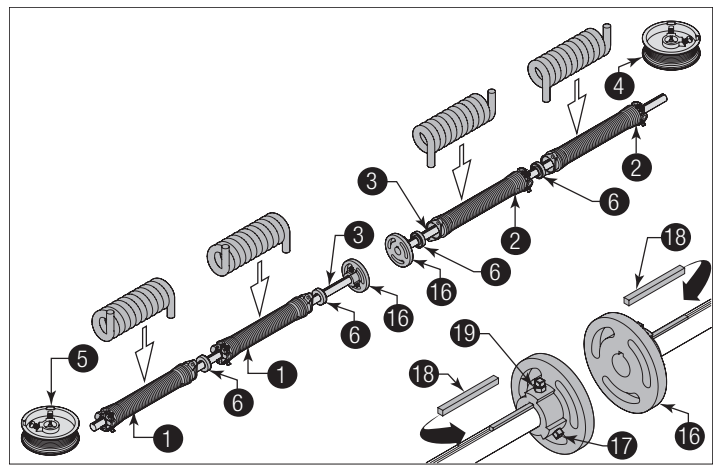

Figure 49

1	Red Winding Cone	6	Center Bracket Bearing
2	Black Winding Cone	16	Coupler Halves
3	Torsion Keyed Shafts	18	Key
4	Black Cable Drum	17	Set Screws
5	Red Cable Drum	19	Locking Nut

18g. With assistance and starting on the left hand side of door, pick up the left hand torsion spring assembly (20) and slide one end of the torsion keyed shaft through the end bearing bracket (7).

18h. Lay the other side of the torsion keyed shaft into the center bracket (8).

18i. Repeat the same process for the right hand torsion spring assembly (21).

18j. Position both torsion keyed shafts so that equal amounts (22) of the shafts extend from each end bearing brackets.

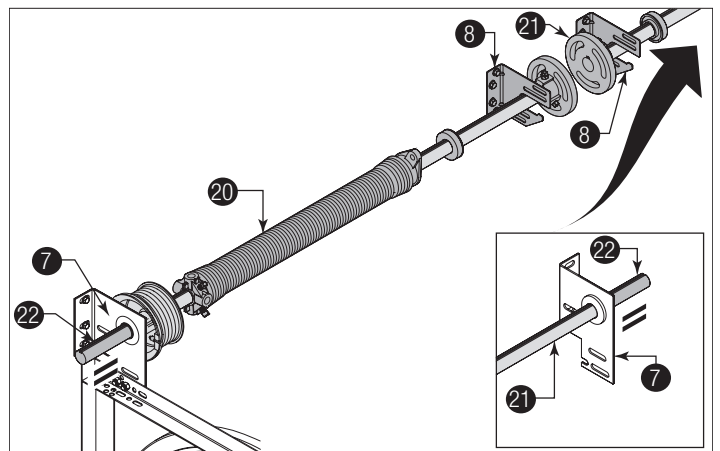

Figure 50, Left Side Shown

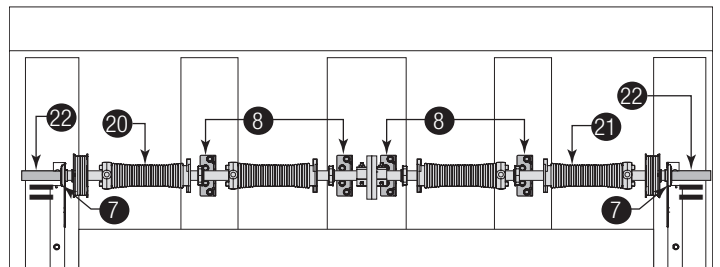

Figure 51



20	Left Hand Torsion Spring Assembly	21	Right Hand Torsion Spring Assembly
7	End Bearing Bracket	22	Equal Amounts
8	Center Bracket		

1	Spring Warning Tag(s)	5	Center Bracket
2	Center Bracket Bearing	6	3/8" - 16 x 1-1/2" Hex Head Bolts
3	Spring	7	3/8" - 16 Nuts
4	Stationary Spring Cone(s)		

## 19 ATTACHING SPRINGS TO CENTER BRACKET

**NOTE:** Refer to Package Contents / Breakdown of Parts, to determine which Center Bracket(s) came with your door.

**NOTE:** Refer to Package Contents / Breakdown of Parts, to determine if your door came with a coupler assembly.

**IMPORTANT:** The spring warning tag(s) 1 supplied must be securely attached to the stationary spring cone(s) in plain view. Should a replacement spring warning tag be required, contact Wayne Dalton for free replacements.

**NOTE:** Measure the diameter of your springs. If your spring diameter is 3-3/4", the springs do not share center brackets. If your spring diameter is either 2" or 2-5/8", then two springs will share the same center bracket, unless a coupler assembly is provided.

See Figure 52 and Figure 53 for the following steps.

**If you don't have a Coupler Assembly:**

19a. Slide center bracket bearing 2 into the spring 3.

19b. Align the stationary spring cone(s) 4 with the holes in the center bracket 5.

19c. Secure the torsion spring(s) to the center bracket with (2) 3/8" - 16 x 1-1/2" hex head bolts 6 and (2) 3/8" - 16 nuts 7.

**IMPORTANT:** Never use more than one bearing when attaching two springs to one center bracket.

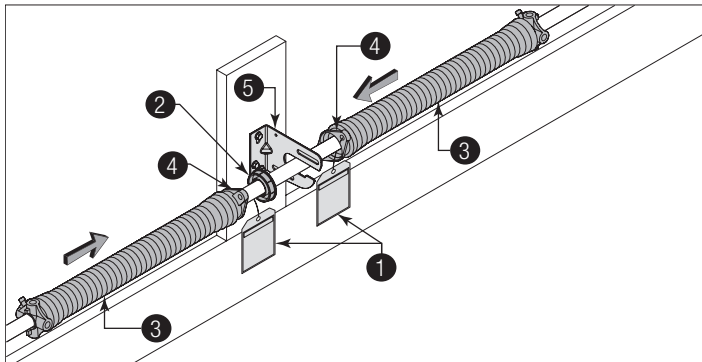

Figure 52

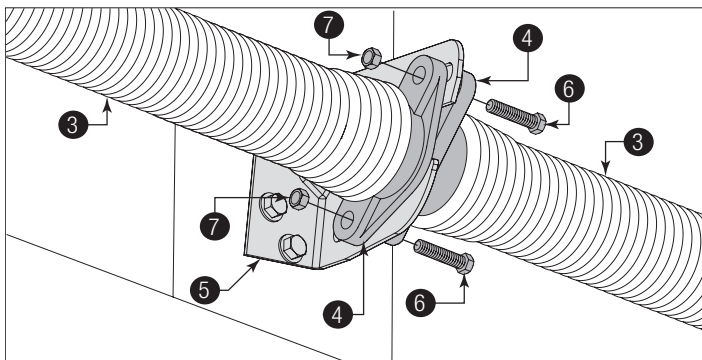

Figure 53

See Figure 54 for the following steps.

**If you have a Coupler Assembly:**

19a. Slide center bracket bearing 2 into the spring 3.

19b. Align the stationary spring cone 4 with the holes in the center bracket 5.

19c. Secure the torsion spring to the center bracket with (2) 3/8" - 16 x 1-1/2" hex head bolts 6 and (2) 3/8" - 16 nuts 7.

19d. Repeat the same process for the other center bearing bracket.

19e. At the middle of the two center bearing brackets, re-assemble the coupler assembly 8 by loosely fastening the coupler halves 9 together using the (3) 3/8" - 16 x 1-1/2" hex head screws 10, (6) 3/8" washers 11, (3) 3/8" lock washers 12 and the (3) 3/8" - 16 hex nuts 13, previously removed.

**NOTE:** Ensure both torsion keyed shafts have equal amounts of the shafts extending from each end bearing bracket.

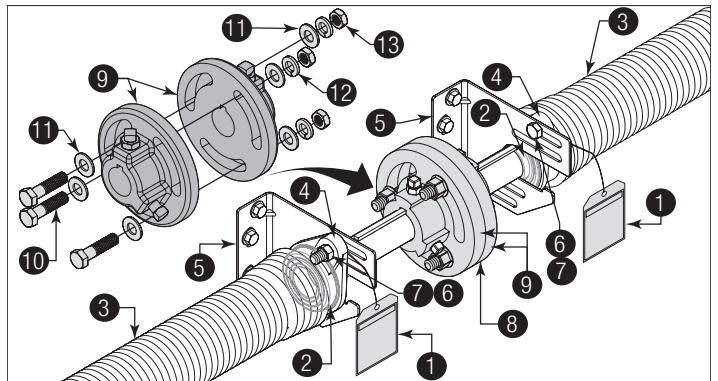

Figure 54

1	Spring Warning Tag(s)	8	Coupler Assembly
2	Center Bracket Bearing	9	Coupler Halves
3	Spring	10	3/8" - 16 x 1-1/2" Hex Head Screws
4	Stationary Spring Cone(s)	11	3/8" Washers
5	Center Bracket	12	3/8" Lock Washers
6	3/8" - 16 x 1-1/2" Hex Head Bolts	13	3/8" - 16 Hex Nuts
7	3/8" - 16 Nuts		

## 20 ATTACHING COUNTERBALANCE LIFT CABLES

See Figure 55 through Figure 57 for the following steps.

20a. Starting on the left hand side, thread the counterbalance lift cable 1 up and around the front side of the left hand cable drum 2.

**IMPORTANT:** Verify that there are no obstructions in the travel path of the door sections or counterbalance lift cables.

**NOTE:** Always assemble the left hand cable and cable drum first to help maintain equal cable tension on both sides of the door.

## NOTICE

FAILURE TO REMOVE ALL SLACK OUT OF THE COUNTERBALANCE LIFT CABLES, WILL CAUSE DOOR OPERATIONAL PROBLEMS.

20b. Hook **3** the counterbalance lift cable into the left hand cable drum. Slide the left hand cable drum up against the left hand end bearing bracket **4**. Counterbalance lift cable should terminate at the 3 o'clock position **10** - 6 o'clock position **11**.

## WARNING

**TO AVOID RISK OF COUNTERBALANCE FAILURE CAUSING DEATH OR SERIOUS INJURY, THE COUNTERBALANCE LIFT CABLE MUST TERMINATE BETWEEN THE 3 O'CLOCK AND 6 O'CLOCK POSITION. IF THE COUNTERBALANCE CABLE DOES NOT TERMINATE IN THE CORRECT POSITION, THE CABLE LENGTH MUST BE CORRECTED BY A TRAINED DOOR SYSTEMS TECHNICIAN BEFORE CONTINUING INSTALLATION.**

**NOTE:** If you have torsion keyed shaft(s) **6**, insert (1) key **5** into the slot of both the cable drum and the slot in the torsion keyed shaft, as shown.

20c. Rotate the left hand drum and torsion shaft until counterbalance lift cable is taut. Now attach locking pliers **7** to the torsion shaft **6** and brace locking pliers up against jamb **8** to keep counterbalance lift cable taut.

20d. Tighten the set screws **9** in the drum to 14-15 ft-lbs of torque (once set screws contact the torsion shaft, tighten screws an additional 1/2 turn for solid shaft and one full turn for tubular shaft).

20e. Repeat for right hand side.

**IMPORTANT:** Inspect each counterbalance lift cable making sure it is seated properly onto the cable drum and that both counterbalance lift cables have equal tension.

### 20f. Check Counterbalance Lift Cables for Equal Tension:

1. Attach locking pliers to track above top roller.
2. Grasp cable at approximate mid-door height location.
3. Draw cable toward you about 1/2" to 1" and release, noting the response of the cable.
4. Repeat above steps for other cable.
5. Adjust cable tension as needed until right and left cables both respond the same.

20g. Once the counterbalance cables are set and if applicable tighten the coupler assembly together by tightening the (3) 3/8" - 16 nylon hex nuts to secure the coupler halves together.

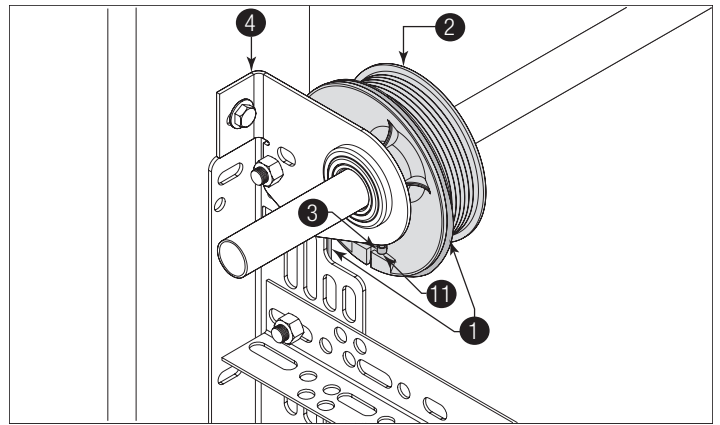

Figure 56, Left Side Shown

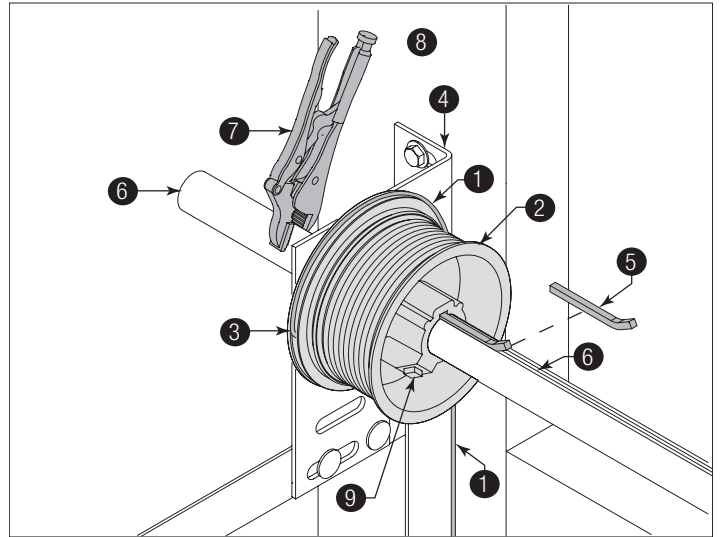

Figure 57, Left Side Shown

1	Counterbalance Lift Cable	7	Locking Pliers
2	Cable Drum	8	Jamb
3	Hook	9	Set Screws
4	End Bearing Bracket	10	3 O'Clock Position
5	Key	11	6 O'Clock Position
6	Torsion Shaft / Torsion Keyed Shaft		

## 21 CHALKING TORSION SPRING(S)

**NOTE:** If your springs have stenciling, then skip this step.

See Figure 58 for the following steps.

21a. Draw a chalk line horizontally along the center of the torsion spring coils **1**. As the torsion spring is wound, the chalk line will create a spiral **2**. This spiral can be used to count and determine the number of turns that are applied on the torsion spring **3**.

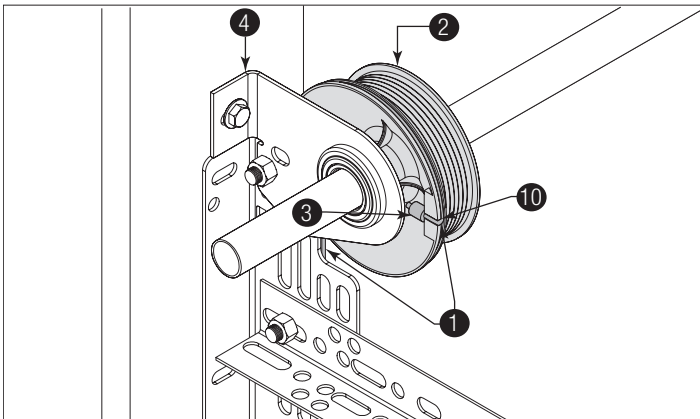

Figure 55, Left Side Shown

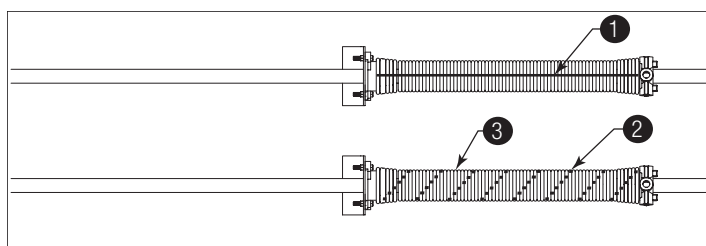

Figure 58

1	Draw horizontal chalk line prior to winding	3	Spirals created after winding
2	Spiral		

Winding Bars (Steel Rods)	Size Of Winding Bar (Inches)	Spring Inner Diameter Used On
	1/2" dia. x 18"	2" and 2-5/8"
	5/8" dia. x 24"	3-3/4"

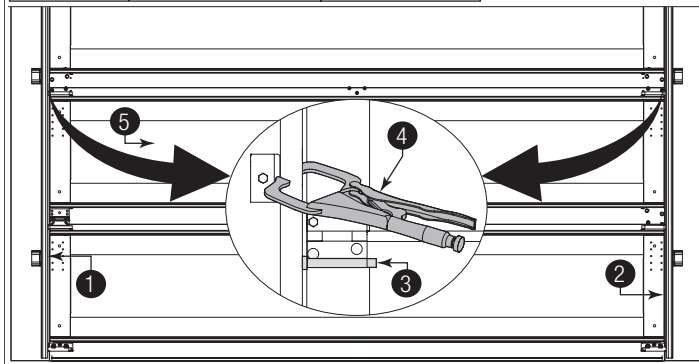

Figure 59

1	Left Side Vertical Track	5	Bottom Section
2	Right Side Vertical Track	6	Second Section
3	Track Roller	7	Intermediate Section
4	Locking Pliers		

## 22 SECURING DOOR FOR SPRING WINDING

See Figure 59 for the following steps.

22a. With the door in the fully closed position, place locking pliers (4) onto both vertical tracks (1) and (2) just above the third track roller (3). This is to prevent the garage door from rising while winding spring(s). Ensure that:

22b. **Check the following before attempting to wind torsion spring(s):**

- Counterbalance lift cables are secured at bottom corner brackets, See Figure 14.
- Counterbalance lift cables are unobstructed in their route to cable drums.
- Counterbalance lift cables are correctly installed and wound onto cable lift drums.
- Counterbalance lift cables are taut and have equal tension on both sides.
- Cable lift drums are against end bearing brackets and set screws are tight.
- Torsion spring or springs are installed correctly.
- Review the label attached to the spring warning tag, to determine number of spring turns required.

### WARNING

FAILURE TO PLACE LOCKING PLIERS ONTO VERTICAL TRACKS CAN ALLOW DOOR TO RAISE DURING SPRING WINDING AND CAUSE SEVERE OR FATAL INJURY.

### CAUTION

TO AVOID POSSIBLE DAMAGE TO YOUR DOOR, THE DOOR MUST BE CLOSED AND LOCKED WHEN WINDING OR MAKING ANY ADJUSTMENTS TO THE SPRING(S).

## 23 WINDING SPRING(S)

### DANGER

WINDING SPRING IS AN EXTREMELY DANGEROUS PROCEDURE AND SHOULD BE PERFORMED ONLY BY A TRAINED DOOR SYSTEM TECHNICIAN USING PROPER TOOLS AND INSTRUCTIONS.

### WARNING

USE ONLY SPECIFIED WINDING BARS, AS STATED IN STEP SECURING DOOR FOR SPRING WINDING. DO NOT SUBSTITUTE WITH SCREWDRIVERS, PIPE, ETC. OTHER TOOLS MAY FAIL OR RELEASE FROM THE SPRING CONE AND CAUSE SEVERE OR FATAL INJURY.

### DANGER

PRIOR TO WINDING THE SPRING, ENSURE YOU'RE WINDING IN THE PROPER DIRECTION AS SHOWN IN FIGURE 60. OTHERWISE THE SPRING FITTING MAY RELEASE FROM SPRING AND RESULT IN SEVERE OR FATAL INJURY.

23a. Position a ladder slightly to the side of the spring so that the winding cone is easily accessible, and so your body is not directly in line with the winding bars (1).

23b. Check the label attached to the spring warning tag (2) for the required number of complete turns to balance your door.

#### How to Wind Torsion Springs:

1. Insert one winding rod snugly into winding cone (3), to full socket depth.
2. Maintaining a tight grip on the winding rod rotate it slowly in the proper direction (4), as shown below.
3. If there is any slippage of the winding rod in the winding cone socket, reverse the direction of winding and return the cone to its original position. Remove the winding rod from the winding cone socket. Reseat the winding rod in the socket. Start over at Step #1.
4. When the winding rod is vertical above the winding cone, insert another winding rod into one of the other sockets, being careful to seat it snugly and at full socket depth.

5. Hold the spring with the second winding bar, and remove the first.
6. Repeat Steps #2 through #5 until the complete turns have been applied.

**IMPORTANT:** Check the warning tag(s) attached to the spring(s) for the required number of complete turns, to balance your door.

**IMPORTANT:** After winding the spring(s), tighten the set screws 5 in the winding cone to 14-15 ft-lbs of torque (once set screws contact the torsion shaft 6, tighten screws an additional 1/2 turn for solid shaft and one full turn for tubular shaft).

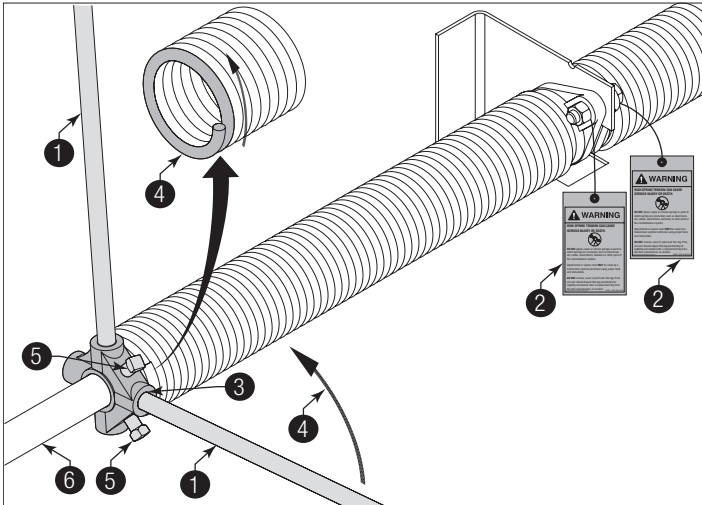

Figure 60

1	Approved Winding Rods	4	Proper Direction
2	Spring Warning Tag	5	Set Screws
3	Winding Cone	6	Torsion Shaft

## 24 ATTACHING REAR BACK HANGS (NOT INCLUDED)

### WARNING

IN THE EVENT THE SPRING(S) WERE OVER-WOUND, HOLD THE DOOR DOWN FIRMLY AND CAUTIOUSLY REMOVE LOCKING PLIERS FROM VERTICAL TRACKS TO PREVENT IT FROM RISING UNEXPECTEDLY.

See Figures 61, 62, and 63 for the following steps.

24a. Raise the door until the top section and half of the next section are in the horizontal track radius. Do not raise door any further since rear of horizontal tracks are not yet supported.

### WARNING

RAISING THE DOOR FURTHER INTO THE LOOSE HORIZONTAL TRACKS CAN RESULT IN DOOR FALLING CAUSING DEATH OR SERIOUS INJURY.

**IMPORTANT:** If an opener is installed, position horizontal tracks one hole above level when securing them to the rear back hangs.

24b. Using the chart below, select the appropriate perforated angle. Fabricate and install rear back hangs, as shown.

Perforated Angle Gauge Weight Limitations:	
Perforated Angle Gauge	Door Balance Weight
2" x 2" x 12 Gauge	800 lbs. to 1600 lbs.
1-1/4" x 1-1/4" x 13 Gauge	305 lb. to 610 lb.
1-1/4" x 1-1/4" x 15 Gauge	220 lb. to 440 lb.
1-1/4" x 1-1/4" x 16 Gauge	175 lb. to 350 lb.

### WARNING

KEEP HORIZONTAL TRACKS PARALLEL AND WITHIN 3/4" TO 7/8" (19 MM - 22 MM) MAXIMUM OF DOOR EDGE. OTHERWISE THE TRACK ROLLERS CAN COME OUT AND DOOR WILL FALL, RESULTING IN DEATH OR SERIOUS INJURY.

### WARNING

MAKE SURE BACK HANGS ARE BRACED SUFFICIENTLY TO RESIST ANY MOTION DURING SPRING APPLICATION AND DOOR TRAVEL. IF BACK HANGS PIVOT OR DEFLECT, ADD REINFORCEMENT UNTIL THEY REMAIN FIRM AND STATIONARY. ANY BACK HANG THAT HAS BEEN BENT MUST BE REPLACED. FAILURE TO SECURELY BRACE THE HORIZONTAL TRACK CAN RESULT IN DOOR FALLING CAUSING DEATH OR SERIOUS INJURY.

### NOTICE

DO NOT SUPPORT THE WEIGHT OF THE DOOR ON ANY PART OF THE REAR BACK HANGS THAT IS 4" (102 MM) OR MORE BEYOND A SOUND FRAMING MEMBER.

### NOTICE

IF REAR BACK HANGS ARE TO BE INSTALLED OVER DRYWALL, USE TWO 5/16" X 2" HEX-HEAD LAG SCREWS AND MAKE SURE LAG SCREWS ENGAGE INTO SOLID STRUCTURAL LUMBER.

### DANGER

FAILURE TO ASSEMBLE AND ATTACH REAR BACK HANGS PROPERLY ACCORDING TO THE ABOVE INSTRUCTIONS MAY RESULT IN DOOR FALLING WHEN RAISED, CAUSING DEATH OR SERIOUS INJURY.

### NOTICE

PERFORATED ANGLE MUST BE ATTACHED TO SOUND FRAMING MEMBERS AND NAILS SHOULD NOT BE USED.

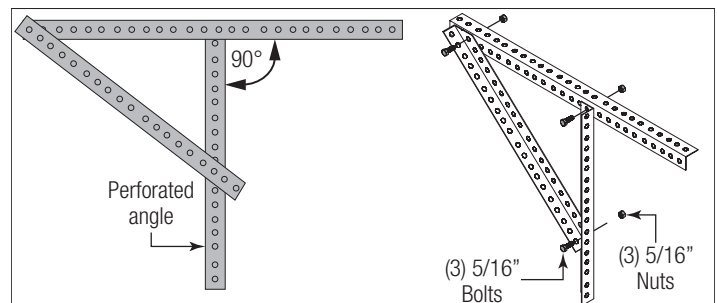

Figure 61

## 25 BALANCING DOOR

### CAUTION

WINDOWS MAY CAUSE THE TOP SECTION TO BE SIGNIFICANTLY HEAVIER THAN THE REMAINING SECTIONS. TO PREVENT ANY SUDDEN DOOR ACCELERATION BETWEEN THE TOP AND BOTTOM, MOTOR OPERATE ALL DOORS WITH WINDOWS.

### DANGER

EXTREME CAUTION SHOULD BE USED WHEN MAKING ADJUSTMENTS TO THE SPRINGS AS FAILURE TO FOLLOW THE INSTRUCTIONS OR USE APPROVED WINDING BARS CAN LEAD TO DEATH OR SERIOUS INJURY TO PERSONS OR PROPERTY. BEFORE ATTEMPTING TO MAKE ADJUSTMENTS TO THE SPRING, MAKE SURE YOU HAVE READ AND UNDERSTAND THE INSTRUCTIONS. IF YOU ARE UNCLEAR ON ANY ASPECT OF THE INSTALLATION PROCEDURES, YOU SHOULD CONSULT A TRAINED DOOR SYSTEMS TECHNICIAN.

See Figure 64 for the following steps.

25a. Remove locking pliers. Lift door and check its balance. Adjustments to the required number of spring turns stated may be necessary. If door rises off floor more than 2 ft. under spring tension alone, reduce spring tension. If the door is hard to rise or drifts down on its own, add spring tension. A poorly balanced door can cause garage door operator problems.

25b. To adjust spring tension, fully close door. Apply locking pliers to track above third track roller. Place locking pliers on torsion shaft, as shown in Step Attaching Counterbalance Lift Cables. Insert a winding rod ① into the winding cone. Push upward on the winding rod slightly while carefully loosening the set screws ② in the winding cone ③.

### WARNING

BE PREPARED TO SUPPORT THE FULL FORCE OF THE TORSION SPRING ONCE THE SET SCREWS ARE LOOSE. IF NOT PREPARED, THEN THE WINDING BAR CAN MOVE SUDDENLY AND COME OUT OF THE WINDING CONE AND CAUSE SEVERE OR FATAL INJURY.

Carefully adjust spring tension 1/4 turn. Retighten both set screws to 14-15 ft. lbs. of torque in the winding cone and repeat for the other side. Recheck door balance and re-adjust spring tension if needed.

**IMPORTANT:** Do not adjust more than 1 turn from the recommended number of turns.

If the door still does not operate easily, lower the door into the closed position, unwind spring(s) completely, and recheck the following items:

25c. Is the door level?

25d. Are the torsion shaft and flag angles / angle mount level and plumb?

25e. Does the distance between the flag angles / angle mount equal door width plus 3-3/8" to 3-1/2"?

25f. Do the counterbalance lift cables have equal tension? Adjust if necessary.

25g. Rewind the spring(s).

25h. Make sure door is not rubbing on jambs.

**IMPORTANT:** If door still does not balance properly, then contact a trained door system technician.

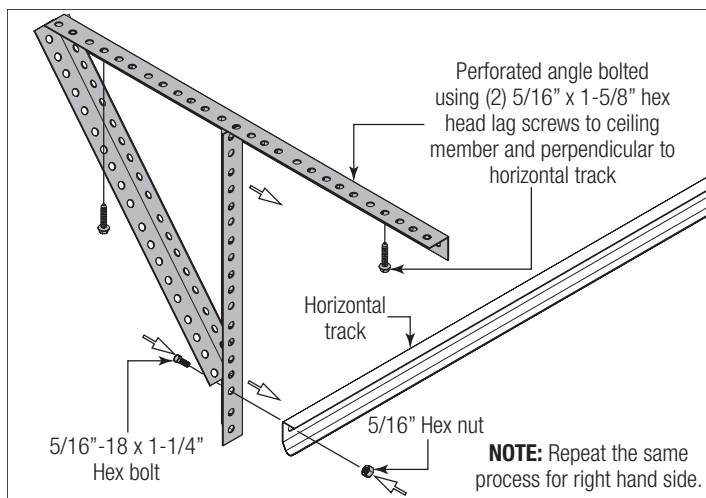

Figure 62

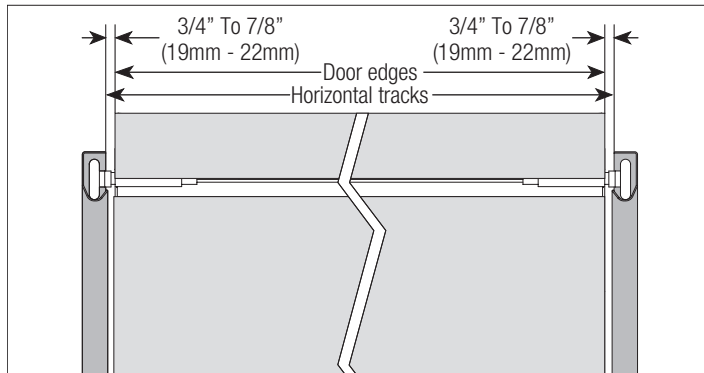
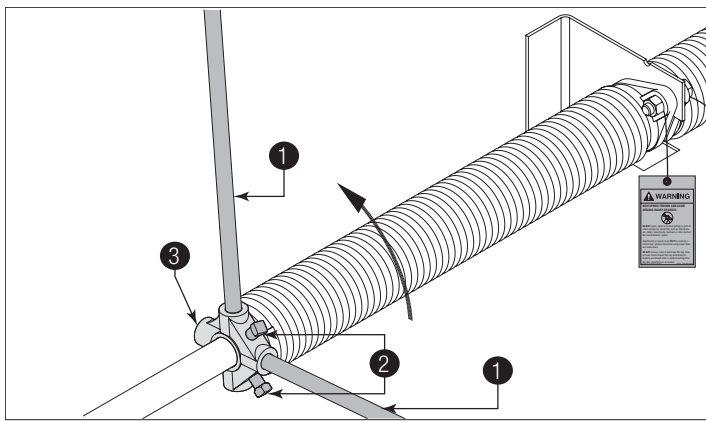

Figure 63



**Figure 64**

1	Winding Rod	3	Winding Cone
2	Set Screws		

# OPTIONAL INSTALLATION

## Door Arm Hookup

Align hole in the door arm with holes in drawbar operator bracket tabs, as shown. Insert 5/16" x 1-1/4" clevis pin, making sure hole in clevis pin is outside of second tab of drawbar operator bracket. Insert hairpin cotter into clevis pin hole and spread hairpin cotter to secure assembly, as shown.

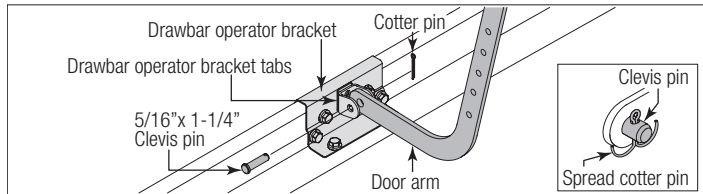

## Trolley Arm Configuration

Measure the horizontal radius of the horizontal track to determine if you have a 12" or 15" radius horizontal track, as shown in FIG. 1; if you have a low headroom door skip this step. Determine center line of the door. Mark vertical line at this point on the header, as shown in FIG. 4. Raise the door slightly until the top section reaches the highest point of travel (high arc), as shown in FIG. 2 and FIG. 3 for low headroom. Using a level, mark this high arc point onto the header where it intersects the vertical center line, as shown in FIG. 4. Hold the wall bracket's bottom edge 1/2" - 1" (room permitting) above the high arc line and centered on the vertical center line, as shown in FIG. 4. Mark the wall bracket's mounting holes on the header wall and then refer to your garage door operator manual for pre-drilling and securing the wall bracket to header.

**NOTE:** Refer to your operator manual for specific details on how to assemble the curved and straight arm.

Align hole in the appropriate arm with holes in drawbar operator bracket tabs, as shown in step, Trolley Arm Hookup. Insert 5/16" x 1-1/4" clevis pin, making sure hole in clevis pin is outside of second tab of drawbar operator bracket. Insert cotter pin into clevis pin hole and spread hairpin cotter to ensure it will secure assembly.

**NOTE:** Depending on your door configuration, you could have alternative drawbar operator brackets. Refer to your alternate drawbar operator bracket insert.

## WARNING

**PRIOR TO INSTALLING THE OPERATOR TROLLEY ARM TO THE DOOR, UNPLUG THE GARAGE DOOR OPERATOR. WITH THE DOOR IN THE FULLY CLOSED POSITION, PLACE LOCKING PLIERS ONTO BOTH VERTICAL TRACKS JUST ABOVE THE THIRD TRACK ROLLER. THIS IS TO PREVENT THE GARAGE DOOR FROM RISING UNEXPECTEDLY WHILE INSTALLING THE OPERATOR TROLLEY ARM TO THE DOOR. AFTER INSTALLING THE OPERATOR TROLLEY ARM TO THE DOOR REMOVE THE LOCKING PLIERS AND PLUG THE GARAGE DOOR OPERATOR BACK INTO THE OUTLET.**

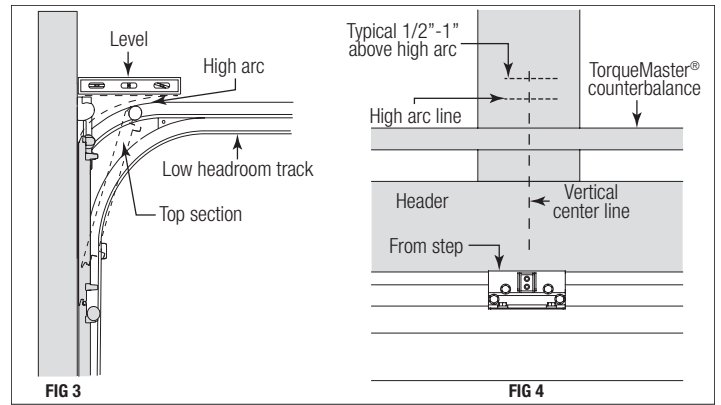
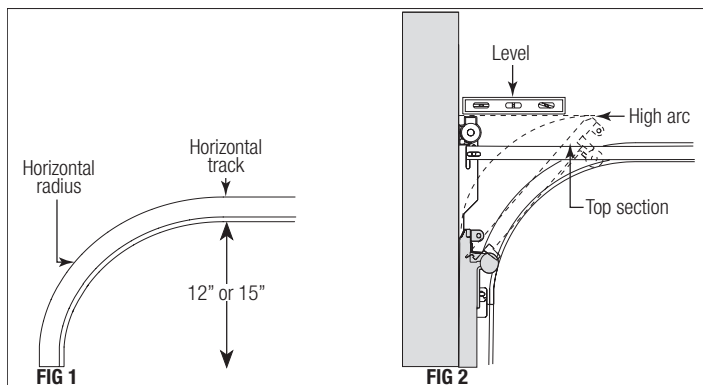

## Inside Lock

Install the inside lock on the second section of the door. Secure the lock to the section with (4) 1/4" - 20 x 11/16" self drilling screws. Square the lock assembly with the door section, and align with the square hole in the vertical track. The inside lock should be spaced approximately 1/8" away from the section edge.

**IMPORTANT:** Inside lock(s) must be removed or made inoperative in the unlocked position if an operator is installed on this door.

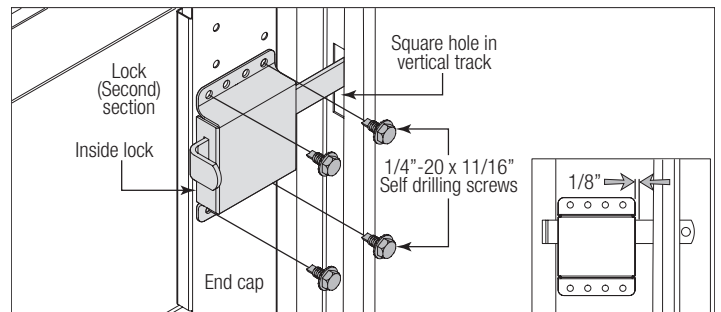

## Pull Down Rope

### **WARNING**

**DO NOT INSTALL PULL DOWN ROPE ON DOORS WITH OPERATORS. CHILDREN MAY BECOME ENTANGLED IN THE ROPE CAUSING SEVERE OR FATAL INJURY.**

Measure and mark the jamb approximately 48" to 50" (1220 to 1270 mm) from floor on the right or left side of jamb. Drill 1/8" pilot hole for no. 6 screw eye. Tie the pull down rope to the no. 6 screw eye and to the bottom corner bracket, as shown.

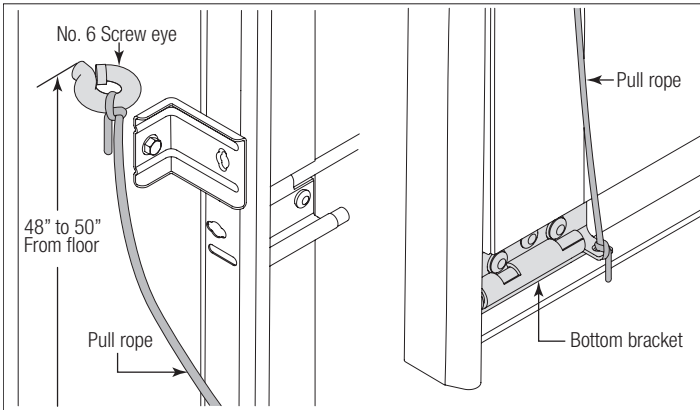

## Step Plate

Make one mark 1" (25 mm) up from the center of bottom edge of the bottom section and another mark 2-3/16" (56 mm) up from the first mark.

**NOTE:** Top of step plate can be no higher than 8" from the bottom of the door.

Drill a 7/16" (11 mm) hole through the section at each mark and insert the outside step plate. Loosely fasten step plate slide to base with (1) 1/4" - 20 x 5/8" carriage bolt and nut. Align inside step plate holes and fasten from inside using the #8 screws provided. Install one #8 x 3/4" screw in the bottom step plate hole. The screw in the top hole varies with door models. Use the screw size shown below for your model door.

a) #8 x 3/4" screw for model 9100

b) #8 x 1" screw models 9405/9605

Tighten 1/4" - 20 carriage bolt and nut.

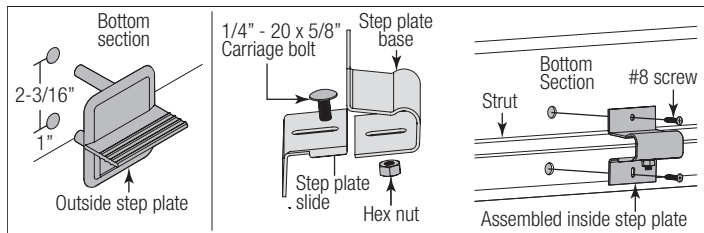



# MAINTENANCE

## Cleaning Your Garage Door

### NOTICE

DO NOT USE A PRESSURE WASHER ON YOUR GARAGE DOOR!

While factory-applied finishes on garage doors are durable, it is desirable to clean them on a routine basis. Some discoloration of the finish may occur when a door has been exposed to dirt-laden atmosphere for a period of time. Slight chalking may also occur as a result of direct exposure to sunlight. Cleaning the door may help to restore the appearance of the finish. To maintain an aesthetically pleasing finish of the garage door, a periodic washing of the garage door is recommended.

#### The Following Cleaning Solution is Recommended:

A mild detergent solution consisting of one cup detergent (with less than 0.5% phosphate) dissolved into five gallons of warm water will aid in the removal of most dirt.

### NOTICE

THE USE OF DETERGENTS CONTAINING GREATER THAN 0.5% PHOSPHATE IS NOT RECOMMENDED FOR USE IN GENERAL CLEANING OF GARAGE DOORS. BE SURE TO CLEAN BEHIND WEATHER-STRIPS ON BOTH SIDES AND TOP OF DOOR.

### NOTICE

NEVER MIX CLEANSERS OR DETERGENTS WITH BLEACH.

### NOTICE

DO NOT USE ANY WINDOW CLEANING FLUIDS, SCOURING COMPOUNDS, GRITTY CLOTHS OR SOLVENT-BASED CLEANERS OF ANY KIND.

To clean polycarbonate windows, see [www.Wayne-Dalton.com](http://www.Wayne-Dalton.com).

## Painting Your Garage Door

Refer to Instruction Insert "**Field Painting and Finishing Fiberglass or Steel Door Sections**".

## Maintaining The Finish On Your Garage Door

If the factory finish is beginning to fade, the door may require a field applied top clear coat. Depending on environment and usage, this may be necessary after 1 to 3 years of use. Refer to Instruction Insert "**Field Painting and Finishing Fiberglass or Steel Door Sections**".

## Operation And Maintenance

### Operating Your Garage Door:

Before you begin, read all warning labels affixed to the door and the installation instructions and owner's manual. When correctly installed, your Wayne Dalton door will operate smoothly. Always operate your door with controlled movements. Do not slam your door or throw your door into the open position, this may cause damage to the door or its components. If your door has an electric opener, refer to the owner's manual to disconnect the opener before performing manual door operation below.

### Manual Door Operation:

For additional information on manual garage door operation go to [www.dasma.com](http://www.dasma.com) and reference TDS 165.

### CAUTION

**DO NOT PLACE FINGERS OR HANDS INTO SECTION JOINTS WHEN OPENING AND/OR CLOSING A DOOR. ALWAYS USE LIFT HANDLES/SUITABLE GRIPPING POINTS WHEN OPERATING THE DOOR MANUALLY.**

**OPENING A DOOR:** Make sure the lock (if present) are in the unlocked position. Lift the door by using the lift handles/suitable gripping points only. Door should open with little resistance.

**CLOSING A DOOR:** From inside the garage, pull door downward using lift handles/gripping points only. If you are unable to reach the lift handles/suitable gripping points only, use pull-down rope (if present) affixed to the side of door. Door should close completely with little resistance.

### Using An Electric Operator:

**IMPORTANT:** If present, Pull-down rope must be removed and locks must be removed or made inoperative in the unlocked position.

When connecting a drawbar (trolley-type) garage door operator to this door, a drawbar operator bracket must be securely attached to the top section of the door, along with any struts provided with the door. Always use the drawbar operator bracket supplied with the door. To avoid possible damage to your door, reinforce the top section with a strut (may or may not be supplied). The installation of the drawbar operator must be according to manufacturer's instructions and force settings must be adjusted properly. Refer to the owner's manual supplied with your drawbar operator for complete details on installation, operation, maintenance and testing of the operator.

### Maintaining Your Garage Door:

Before you begin, read all warning labels affixed to the door and the installation instructions and owner's manual. Perform routine maintenance steps once a month, and have the door professionally inspected once a year. Review your Installation Instructions and Owner's Manual for the garage door. These instructions are available at no charge from Wayne Dalton, a division of Overhead Door Corporation, P.O. Box 67, Mt. Hope, OH, 44660, or at [www.Wayne-Dalton.com](http://www.Wayne-Dalton.com). For additional information on garage door/operator maintenance go to [www.dasma.com](http://www.dasma.com) and reference TDS 151, 167 and 179.

### Monthly Inspections:

#### 1. Visual Inspection:

Closely inspect jambs, header and mounting surface. Any material found not to be structurally sound must be replaced. It may be necessary to uninstall part or all of the door assembly in order to replace defective material. Refer to the supplemental instructions "Removing an Existing Door/Preparing the Opening" at [www.Wayne-Dalton.com](http://www.Wayne-Dalton.com). Inspect the spring(s), counterbalance lift cables, track rollers, pulleys, rear back hangs and other door hardware for signs of worn or broken parts. Tighten any loose screws and/or bolts, except on bottom corner brackets or on the counterbalance assembly. Check exterior surface of the door sections for any minor cracks. Verify door has not shifted right or left in the opening. If you suspect problems, contact a trained door system technician.

### DANGER

**GARAGE DOOR SPRINGS, COUNTERBALANCE LIFT CABLES, BRACKETS, AND OTHER HARDWARE ATTACHED TO THE SPRINGS ARE UNDER EXTREME TENSION, AND IF HANDLED IMPROPERLY, CAN CAUSE DEATH OR SERIOUS INJURY. ONLY A TRAINED DOOR SYSTEMS TECHNICIAN SHOULD ADJUST THEM, BY CAREFULLY FOLLOWING THE MANUFACTURER'S INSTRUCTIONS.**

## **! WARNING**

**NEVER REMOVE, ADJUST, OR LOOSEN THE BOLTS, SCREWS AND/OR LAG SCREWS ON THE COUNTERBALANCE (END BEARING BRACKETS, DRUMS OR SPRING SYSTEM) OR BOTTOM CORNER BRACKETS OF THE DOOR. THESE BRACKETS ARE CONNECTED TO THE SPRING(S) AND ARE UNDER EXTREME TENSION. TO AVOID POSSIBLE DEATH OR SERIOUS INJURY, HAVE ANY SUCH WORK PERFORMED BY A TRAINED DOOR SYSTEMS TECHNICIAN USING PROPER TOOLS AND INSTRUCTIONS.**

### **Torsion Springs:**

The torsion springs (located above the door) should only be adjusted by a trained door systems technician. **DO NOT** attempt to repair or adjust torsion springs yourself.

### **2. Door Balance:**

Periodically test the balance of your door. If you have a garage door drawbar operator, use the release mechanism so you can operate the door by hand when doing this test. Start with the door in the fully closed position. Using handles or suitable gripping points, lift the door to check its balance. If door lifts by itself (hard to pull down) or if door is difficult to lift (easy to pull down), have it adjusted by a trained door systems technician. **DO NOT** attempt to repair or adjust Torsion Springs yourself.

### **3. Lubrication:**

The door should open and close smoothly. Ensure the door track rollers are rotating freely when opening and closing the door. If track rollers do not rotate freely, clean the door tracks, removing dirt and any foreign substances. Clean and lubricate (use a non-silicon based lubricant) graduated end hinges, center hinges, steel track rollers, bearings and torsion springs (torsion spring coil surfaces). **DO NOT** lubricate plastic idler bearings, nylon track rollers, or the door track. **DO NOT** oil a cylinder lock. If actuation is difficult, use a graphite dust to lubricate.

### **Check for Presence of Safety Labels:**

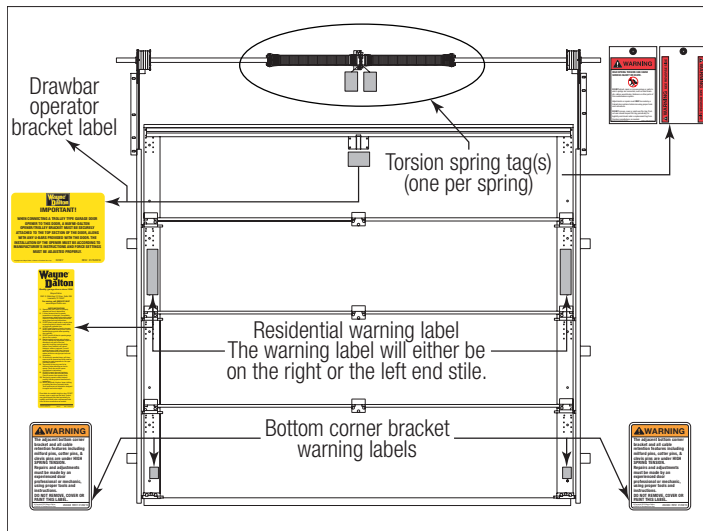

# WARRANTY

## Limited Warranty

### Models 9100, 9405 and 9605

Wayne Dalton, a division of Overhead Door Corporation ("Seller") warrants to the original purchaser of the Models 9100, 9405 and 9605 ("Product"), subject to all of the terms and conditions hereof, that the Product and all components thereof will be free from defects in materials and workmanship for the following period(s) of time, measured from the date of installation:

**LIMITED LIFETIME WARRANTY\*** on the Product sections against:

- Peeling, cracking, or chalking of the original factory-applied coating on the steel sections of the Product.
- The Product becoming inoperable due to rust-through of the steel skin from the core of the Product section, caused by cracking, splitting, or other deterioration of the steel skin, or due to structural failure caused by separation or degradation of the foam insulation.
- The Product hardware (except springs) and the tracks.

**ONE (1) YEAR** on those component parts of the Product not covered by the preceding provisions of this Warranty

\*Limited Lifetime shall mean as long as the original purchaser owns the house in which the Product is originally installed.

**TWO (2) YEARS** on the Model 9405 factory attached overlay material against peeling, cracking, chalking, fading or delamination.

Seller's obligation under this warranty is specifically limited to repairing or replacing, at its option, any part which is determined by Seller to be defective during the applicable warranty period. Any labor charges are excluded and will be the responsibility of the purchaser.

This warranty gives you specific legal rights, and you may also have other rights which vary from state to state. This warranty is made to the original purchaser of the Product only, and is not transferable or assignable. This warranty applies only to Product installed in a residential or other non-commercial application. It does not cover any Product installed in commercial or industrial building applications. This warranty does not apply to any unauthorized alteration or repair of the Product, or to any Product or component which has been damaged or deteriorated due to misuse, neglect, accident, failure to provide necessary maintenance, normal wear and tear, acts of God, or any other cause beyond the reasonable control of Seller or as a result of having been exposed to toxic or abrasive environments, including blowing sand, salt water, salt spray and toxic chemicals and fumes.

ALL EXPRESS AND IMPLIED WARRANTIES FOR THE PRODUCT, INCLUDING BUT NOT LIMITED TO ANY IMPLIED WARRANTIES OF MERCHANTABILITY AND FITNESS FOR A PARTICULAR PURPOSE, ARE LIMITED IN TIME TO THE APPLICABLE WARRANTY PERIOD REFLECTED ABOVE. NO WARRANTIES, WHETHER EXPRESS OR IMPLIED, WILL APPLY AFTER THE LIMITED WARRANTY PERIOD HAS EXPIRED. Some states do not allow limitations on how long an implied warranty lasts, so the above limitation may not apply to you.

IN NO EVENT SHALL SELLER BE RESPONSIBLE FOR, OR LIABLE TO ANYONE FOR, SPECIAL, INDIRECT, COLLATERAL, PUNITIVE, INCIDENTAL OR CONSEQUENTIAL DAMAGES, even if Seller has been advised of the possibility of such damages. Such excluded damages include, but are not limited to, loss of use, cost of any substitute product, or other similar indirect financial loss. Some states do not allow the exclusion or limitation of incidental or consequential damages, so the above limitation or exclusion may not apply to you.

Claims under this warranty must be made promptly after discovery, within the applicable warranty period, and in writing to the authorized distributor or installer whose name and address appear below. The purchaser must allow Seller a reasonable opportunity to inspect any Product claimed to be defective prior to removal or any alteration of its condition. Proof of the purchase and/or installation date, and identification as the original purchaser, may be required. There are no established informal dispute resolution procedures of the type described in the Magnuson-Moss Warranty Act.

• SELLER: \_\_\_\_\_

• SELLER'S ADDRESS: \_\_\_\_\_

\_\_\_\_\_

---

Thank you for your purchase.

---

**PLEASE DO NOT RETURN THIS PRODUCT TO THE STORE**

If you need assistance, please call 1-866-569-3799 (press Option 1) and follow the prompts to contact a customer service representative. They will be happy to handle any questions that you may have.

---

After installation is complete, leave this Installation Instructions And Owner's Manual with the homeowner, or fasten it near garage door for easy reference.

Product may be covered by one or more patents.  
See **[www.wayne-dalton.com/patents](http://www.wayne-dalton.com/patents)** for details.