

INSTALLATION INSTRUCTIONS AND OWNER'S MANUAL

Models 8000 and 8200

RESIDENTIAL
STANDARD LIFT AND FRONT MOUNT LOW HEADROOM INSIDE HOOKUP

TORSION, CUT DOWN

**PLEASE DO NOT RETURN THIS PRODUCT TO
THE STORE**

If you need assistance, please call 1-866-569-3799 (press Option 1) and follow the prompts to contact a customer service representative. They will be happy to handle any questions that you may have.

IMPORTANT NOTICES!

Carefully read and fully understand the enclosed instructions before installing and operating the garage door.

Pay close attention to all warnings and notes.

After installation is complete, fasten this manual near garage door for easy reference.

This Installation document is available at no charge from:

- Your local Wayne Dalton Sales Center
- Online at **www.Wayne-Dalton.com**
- By mailing a request to: Wayne Dalton, a division of Overhead Door Corporation, P.O. Box 67, Mt. Hope, OH., 44660

Table Of Contents

PRE-INSTALLATION	3
Important Safety Instructions	3
REMOVING AN EXISTING DOOR AND PREPARING THE OPENING	5
Package Contents	6
Door Section Identification	8
Tools Required	9
BREAKDOWN OF DOOR COMPONENTS	10
BREAKDOWN OF COUNTERBALANCE COMPONENTS	11
INSTALLATION INSTRUCTIONS	12
Door Installation Instructions	12
COUNTERBALANCE INSTALLATION INSTRUCTIONS	22
Standard Lift Torsion Springs	22
Front Mount LHR Inside Hookup Torsion Springs	29
OPTIONAL INSTALLATION	35
Inside Lock	35
Pull Down Rope	35
MAINTENANCE	36
Cleaning Your Garage Door	36
Painting Your Garage Door	36
Maintaining The Finish On Your Garage Door	36
Operation And Maintenance	36
WARRANTY	38

Important Safety Instructions

DEFINITION OF KEY WORDS USED IN THIS MANUAL:

DANGER

INDICATES A HAZARDOUS SITUATION THAT, IF NOT AVOIDED, WILL RESULT IN DEATH OR SERIOUS INJURY.

WARNING

INDICATES A HAZARDOUS SITUATION THAT, IF NOT AVOIDED, COULD RESULT IN DEATH OR SERIOUS INJURY.

CAUTION

INDICATES A HAZARDOUS SITUATION THAT, IF NOT AVOIDED, COULD RESULT IN MINOR OR MODERATE INJURY.

NOTICE

INDICATES INFORMATION CONSIDERED IMPORTANT, THAT IT IS NOT RELATED TO INJURY, BUT MAY RESULT IN PROPERTY DAMAGE.

IMPORTANT: Required key step for proper door operation.

NOTE: Information only.

Installation:

WARNING

INSTALLING THIS DOOR PROPERLY REQUIRES THE USE OF SPECIAL TOOLS AND TECHNIQUES. ALWAYS USE THE CORRECT TOOLS OR TECHNIQUES WHEN PERFORMING INSTALLATION. FAILURE TO USE PROPER TOOLS OR TECHNIQUES OR ADHERE TO SAFETY MESSAGES, COULD RESULT IN SEVERE OR FATAL INJURY.

DANGER

EXTREME CAUTION SHOULD BE USED WHEN WINDING SPRINGS AS FAILURE TO FOLLOW THE INSTRUCTIONS OR USE THE PROPER TOOLS CAN LEAD TO SERIOUS INJURY TO PERSONS AND PROPERTY. BEFORE ATTEMPTING TO WIND THE SPRING, MAKE SURE YOU HAVE READ AND UNDERSTAND THE INSTRUCTIONS. IF YOU ARE UNCLEAR ON ANY ASPECT OF THE INSTALLATION PROCEDURES, YOU SHOULD CONSULT A TRAINED DOOR SYSTEMS TECHNICIAN.

- READ THESE INSTRUCTIONS CAREFULLY BEFORE ATTEMPTING INSTALLATION. IF YOU ARE IN QUESTION ABOUT ANY OF THE PROCEDURES, DO NOT PERFORM THE WORK. INSTEAD, HAVE A TRAINED DOOR SYSTEMS TECHNICIAN DO THE INSTALLATION OR REPAIRS.
- Wear protective gloves and eye protection during installation, to avoid possible injury.
- **DO NOT** install door in windy conditions. Door could fall during the installation, causing severe or fatal injury.
- Doors 12'-0" wide and larger should be installed by two persons, to avoid possible injury.
- On electrically operated doors, pull down ropes must be removed and locks must be removed or made inoperative in the open (unlocked) position, unless electrical interlocks are installed.
- Impact guns are not recommended. When installing 5/16" lag screws using an electric drill/ driver, the drill/ drivers clutch must be set to deliver no more than 200 in-lbs of torque. Fastener failure could occur at higher settings.
- Check with your local building official for wind load code requirements and building permit information.
- For windloaded doors, the wind performance is achieved via the entire door system and component substitution is not authorized without express permission by the manufacturer.

CAUTION

IF ANY PART OF THE DOOR IS TO BE INSTALLED ONTO PRESERVATIVE-TREATED WOOD, PTFE-COATED OR STAINLESS STEEL FASTENERS MUST BE OBTAINED AND USED. REPLACEMENT FASTENERS MUST BE OF AT LEAST EQUAL STRENGTH AND SIZE AS ORIGINAL FASTENERS. IF THE ORIGINAL FASTENER WAS RED-HEAD, THE REPLACEMENT FASTENER MUST BE RED-HEAD ALSO. CONTACT WAYNE DALTON FOR FASTENER STRENGTH VALUES IF NEEDED.

Operation:

⚠ WARNING

TO PREVENT DEATH OR SERIOUS INJURY WHILE OPERATING THE DOOR, ENSURE THE PATH OF THE DOOR IS NOT OBSTRUCTED BY ANY PERSON OR OBJECT AND ADHERE TO THE FOLLOWING SAFETY MEASURES.

- Operate door only when it is properly adjusted and free from obstructions.
- If a door becomes hard to operate, inoperative or is damaged, immediately have necessary adjustments and/ or repairs made by a trained door system technician using proper tools and instructions.
- **DO NOT** stand or walk under a moving door, or permit anybody to stand or walk under an electrically operated door.
- **DO NOT** place fingers or hands into open section joints when closing a door. Use lift handles/ gripping points when operating door manually.
- **DO NOT** permit children to operate garage door or door controls. Severe or fatal injury could result should the child become entrapped between the door and the floor.
- Visually inspect door and hardware monthly for worn and or broken parts. Check to ensure door operates freely. Test electric opener's safety features monthly, following opener manufacturer's instructions.
- **NEVER** hang tools, bicycles, hoses, clothing or anything else from horizontal tracks. Track systems are not intended or designed to support extra weight.

Potential Hazard	Effect	Prevention
 <p>Moving door</p>	<p>⚠ WARNING</p> <p>Could result in Death or Serious Injury</p>	<p>Keep people clear of opening while Door is moving.</p> <p>Do NOT allow children to play with the Door Opener.</p> <p>Do NOT operate a Door that jams or one that has a broken spring.</p>
 <p>High tension spring</p>	<p>⚠ DANGER</p> <p>Will result in Death or Serious Injury</p>	<p>Do NOT try to remove, install, repair or adjust springs or anything to which door spring parts are fastened, such as, wood blocks, steel brackets, cables or other like items.</p> <p>Installations, repairs and adjustments must be done by a trained door system technician using proper tools and instructions.</p>

IMPORTANT: RIGHT and LEFT hand is determined inside the building looking out.

REMOVING AN EXISTING DOOR AND PREPARING THE OPENING

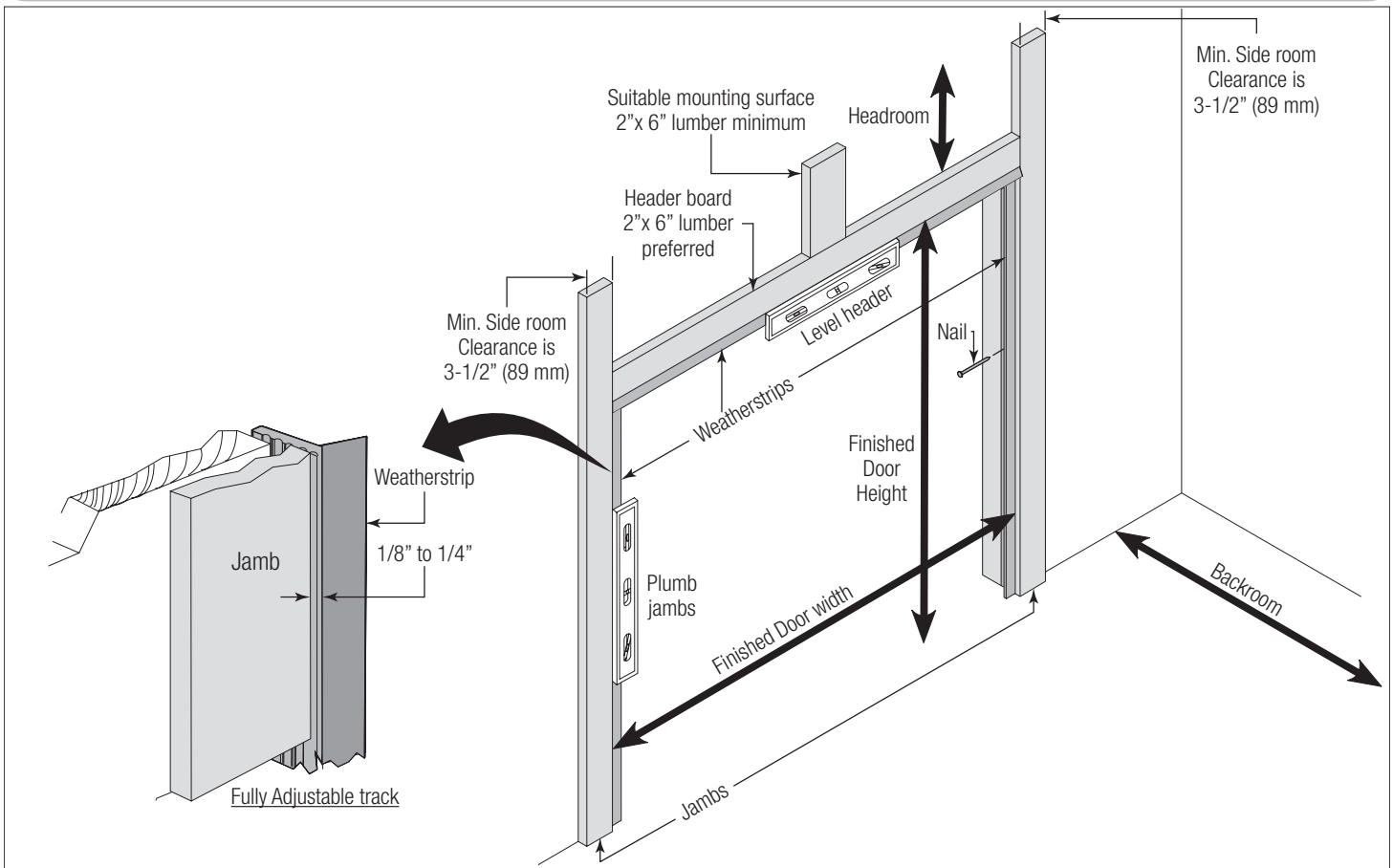

Figure 1

DANGER

AVOID INJURY! A POWERFUL SPRING RELEASING ITS ENERGY SUDDENLY CAN CAUSE SEVERE OR FATAL INJURY. ALWAYS HAVE A TRAINED DOOR SYSTEMS TECHNICIAN, USING PROPER TOOLS AND INSTRUCTIONS, RELEASE THE SPRING TENSION.

WARNING

TO AVOID POSSIBLE INJURY AND TO ENSURE PROPER INSTALLATION, IT'S HIGHLY RECOMMENDED THAT YOU READ AND FULLY UNDERSTAND THE COMPLETE INSTRUCTIONS ON REMOVING AN EXISTING DOOR & PREPARING THE OPENING. THESE ARE AVAILABLE FOR DOWNLOAD AT WWW.WAYNE-DALTON.COM OR AT YOUR LOCAL WAYNE DALTON SALES CENTER.

DANGER

COUNTERBALANCE SPRING TENSION MUST ALWAYS BE RELEASED BEFORE ANY ATTEMPT IS MADE TO START REMOVING AN EXISTING DOOR. EXTREME CAUTION SHOULD BE USED WHEN UNWINDING SPRINGS AS FAILURE TO FOLLOW THE INSTRUCTIONS OR USE PROPER TOOLS CAN LEAD TO SERIOUS INJURY.

See Figure 1 for the following steps.

To ensure secure mounting of track brackets, side and center brackets, or steel angles to new or retro-fit construction, it is recommended to follow the procedures outlined in DASMA technical data sheets #156, #161 and #164 at www.dasma.com.

- The inside perimeter of your garage door opening should be framed with wood jamb and header material.
- The jambs and header must be securely fastened to sound framing members. It is recommended that 2" x 6" lumber be used. The jambs must be plumb and the header level.
- The jambs should extend a minimum of 12" (305 mm) above the top of the opening for Torsion counterbalance systems.
- For low headroom applications, the jambs should extend to the ceiling height. Minimum side clearance required, from the opening to the wall, is 3-1/2" (89 mm).

NOTICE

CLOSELY INSPECT JAMBS, HEADER AND MOUNTING SURFACE. ANY WOOD FOUND NOT TO BE SOUND, MUST BE REPLACED.

For Torsion counterbalance systems, a suitable mounting surface (2" x 6") must be firmly attached to the wall, above the header at the center of the opening.

NOTICE

DRILL A SUITABLE PILOT HOLE IN THE MOUNTING SURFACE TO AVOID SPLITTING THE LUMBER. DO NOT ATTACH THE MOUNTING SURFACE WITH NAILS.

Weatherstrips (Not Included):

Depending on the size of your door, you may have to cut or trim the weatherstrips to properly fit into the header and jambs.

NOTICE

IF NAILING PRODUCT AT 40°F, (4.4°C) OR BELOW, PRE-DRILLING IS REQUIRED.

1. For the header, align the weatherstrip with the inside edge of the header and temporarily secure it to the header with equally spaced nails, approximately 12" to 18" (305 mm - 457 mm) apart.

2. Starting at either side of the jamb, fit the weatherstrip up tight against the temporarily attached weatherstrip in the header and flush with the inside edge of the jamb.

3. Temporarily secure the weatherstrip with equally spaced nails. Repeat for other side. This will keep the bottom door section from falling out of the opening during installation.

Headroom requirement:

Headroom required is defined as the space needed above the top of the door for tracks, springs, etc. to allow the door to open properly.

NOTE: 6" low headroom conversion kit is available for 12" radius only. Contact your local Wayne Dalton dealer.

If the door is to be motor operated, 2-1/2" (64 mm) of additional headroom is required.

Headroom Requirements for Standard Lift Applications	
Track Type	Space Needed
15" Radius track	14-1/2" (368 mm)
12" Radius track	12-1/2" (318 mm)
32" Radius Track	32-1/2" (826 mm)

Headroom Requirements for Low Headroom Applications	
Track Type	Space Needed
6" Front Mount Low Headroom	8-1/2" (216)

Backroom requirement:

Backroom required is defined as the distance needed from the opening back into the garage to allow the door to open fully.

***NOTE:** For door heights from 10'1" to 14'0", refer to your operator manufacture installation instructions for appropriate depth into room.

Backroom Requirements for Standard Lift Applications			
Door Height	Track	Manual Lift	Motor Operated
6'0" to 7'0"	12",15" Radius	98" (2489 mm)	125" (3175 mm)
7'3" to 8'0"		110" (2794 mm)	137" (3480 mm)
8'3" to 9'0"		126" (3200 mm)	168" (4267 mm)
9'3" to 10'0"		138" (3505 mm)	168" (4267 mm)

Backroom Requirements for Low Headroom Applications			
Door Height	Track	Manual Lift	Motor Operated
6'0" to 7'0"	6" Front Mount Low headroom	102" (2591 mm)	125" (3175 mm)
7'1" to 8'0"		114" (2794 mm)	137" (3480 mm)
8'1" to 9'0"		126" (3200 mm)	168" (4267 mm)
9'1" to 10'0"		138" (3505 mm)	168" (4267 mm)

Package Contents

NOTE: Depending on the door model, some parts listed may not be required, and will not be supplied.

Components and Hardware

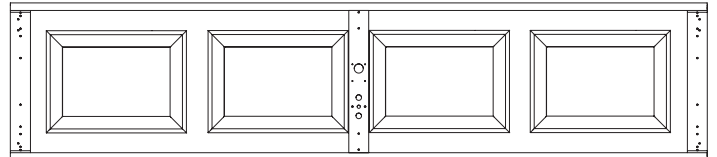

(E1. - E4.) Door sections (as required)

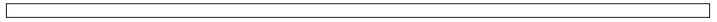

(L9.) Torsion shaft



(A2.) Wall clips
RH/LH (as required)

(A1.) Fully Adjustable flag angles
RH/LH (as required)

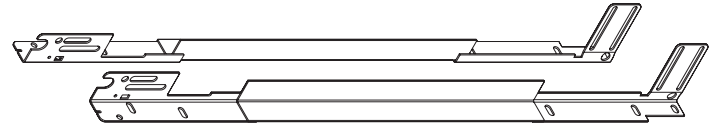

(A3.) Flag angles RH/LH (as required)



(H3.) Vertical tracks RH/LH (as required)

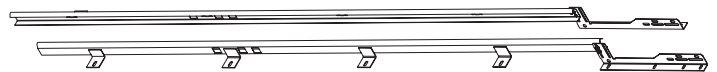

(H4.) Riveted vertical track assemblies RH/LH (as required)

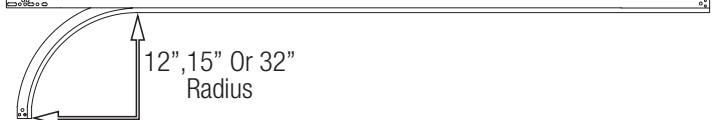

(H1.) Standard Lift Horizontal tracks RH/LH (as required)

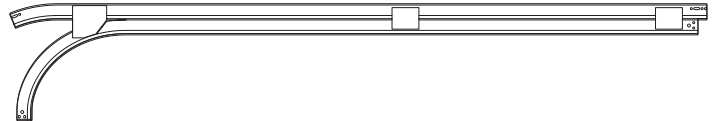

(H2.) Low Headroom Horizontal tracks RH/LH (as required)

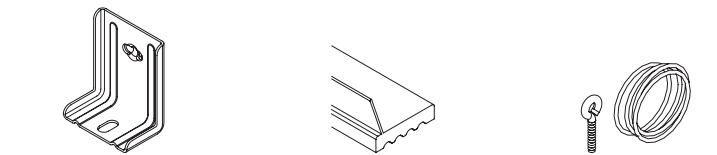

(B1.) Q.I. jamb brackets (as required)

Weather seals & nails (if included)

Pull Down rope (if included)



(C1.) (C2.) Track rollers (as required)

(G1.) 2" Strut (U-shaped) (if included)

(G2.) 3" Strut (U-shaped) (if included)

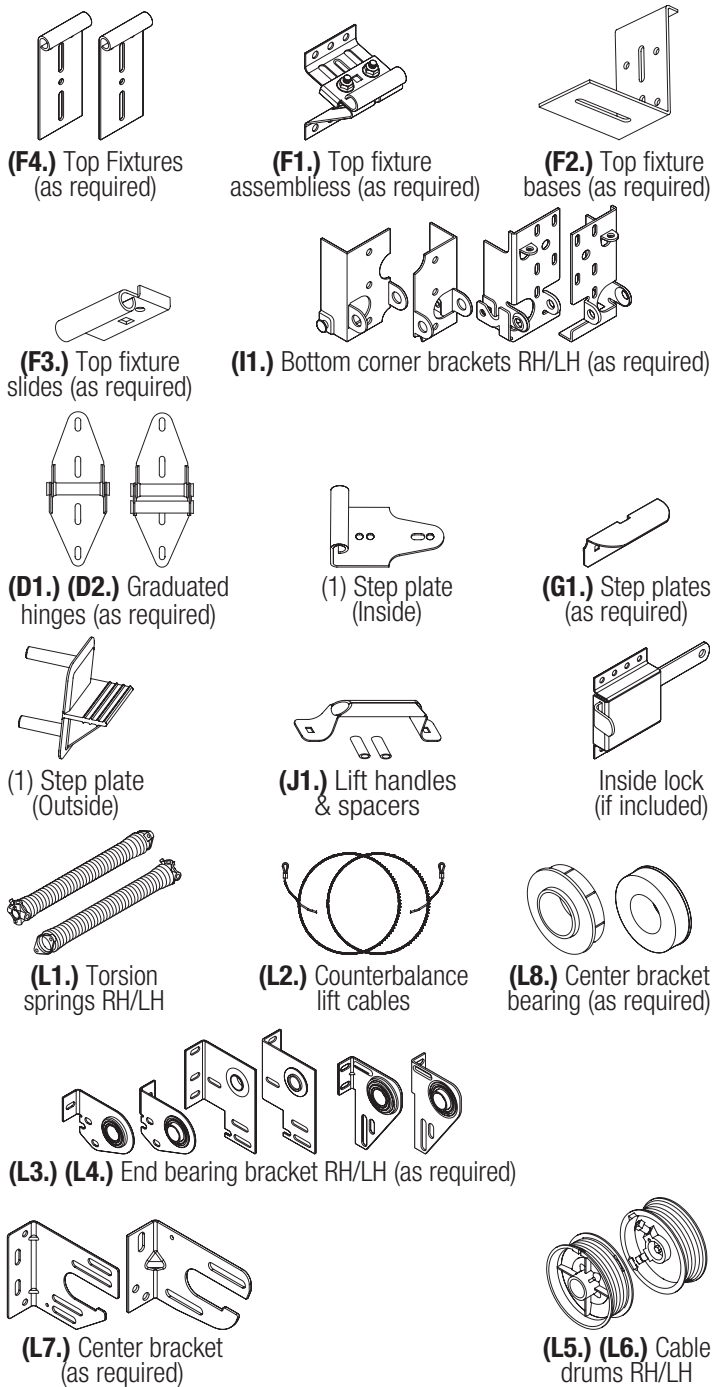
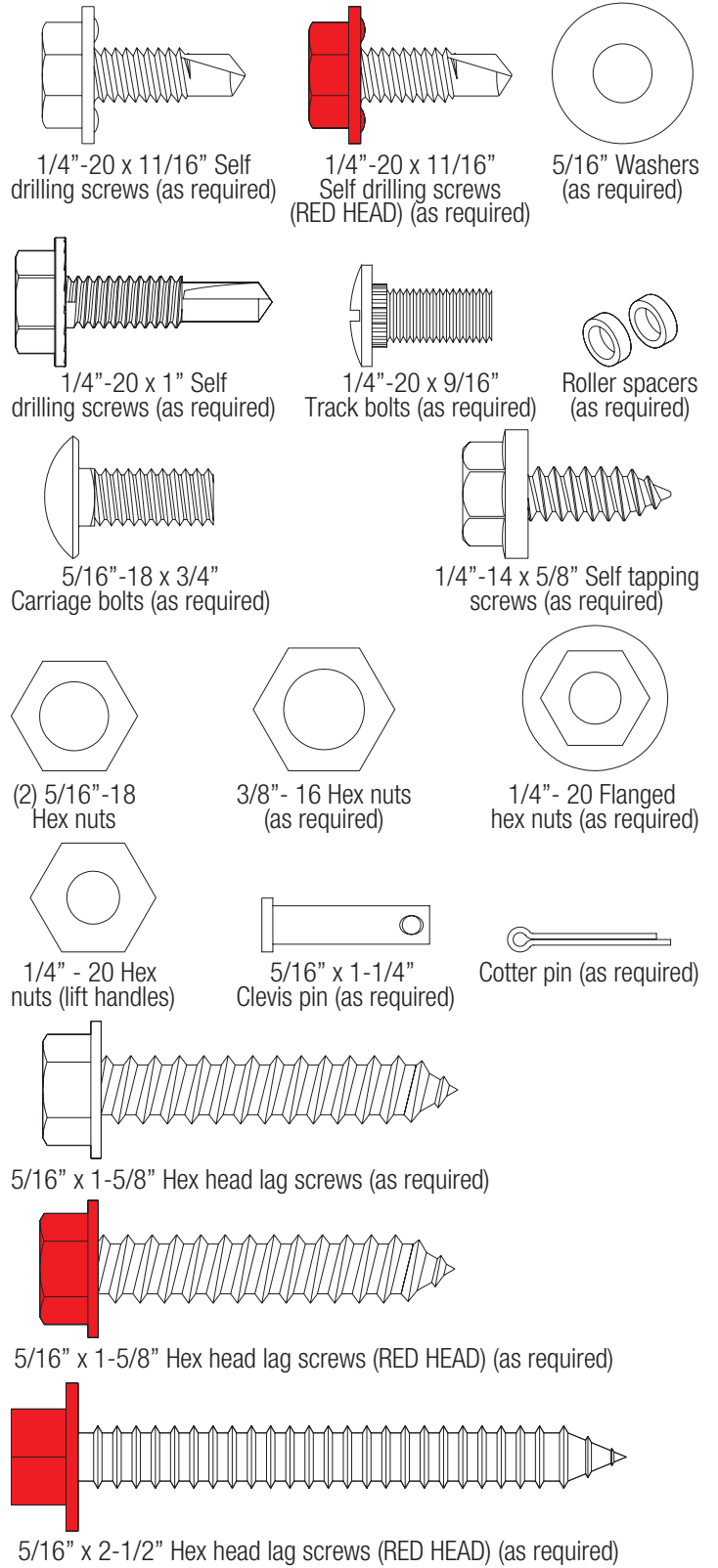

Figure 2

Fasteners



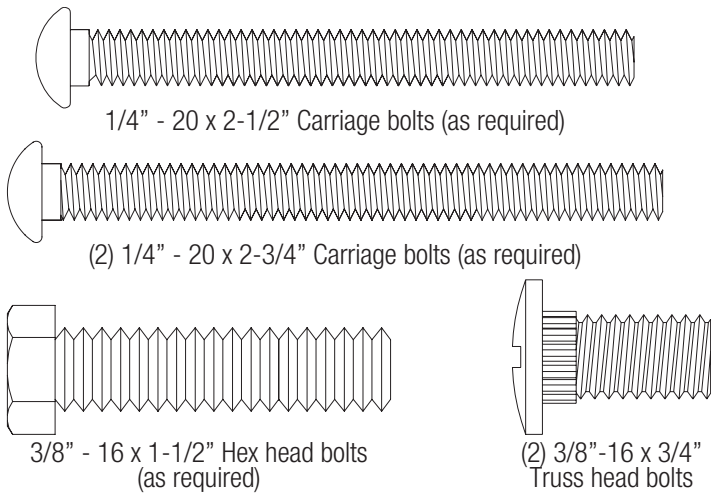

Figure 3

Door Section Identification

Section Quantity 4				
Door Height	Type Of Sections			
	Bottom	Lock	Intermediate Section	Top
6'0"			I	
6'3"	21"		18"	
6'6"	21"		18"	21"
6'9"			21"	18"
7'0"			21"	

Section Quantity 5					
Door Height	Type Of Sections				
	Bottom	Lock	Intermediate(s) Section		Top
			I	II	
7'6"			18"		
7'9"	21"		18"		21"
8'0"	21"		18"		21"
8'3"	21"		18"		21"
8'6"			21"		18"
8'9"			21"		

Section Quantity 6						
Door Height	Type Of Sections					
	Bottom	Lock	Intermediate(s) Section			Top
			I	II	III	
9'0"			18"			

When installing your door you must use sections of the appropriate height in the right stacking order. What section heights you need to use in what order depends on the height of your door.

Unless your door is five sections in height, you will not receive an Intermediate II section.

The **BOTTOM SECTION** can be identified by the factory attached bottom weather seal and by the bottom corner bracket warning labels on each end stile.

The **INTERMEDIATE (INT) I SECTION** may have a warning label attached to either right or left hand end stile of the section. This section is always the 3rd section from the bottom of the door.

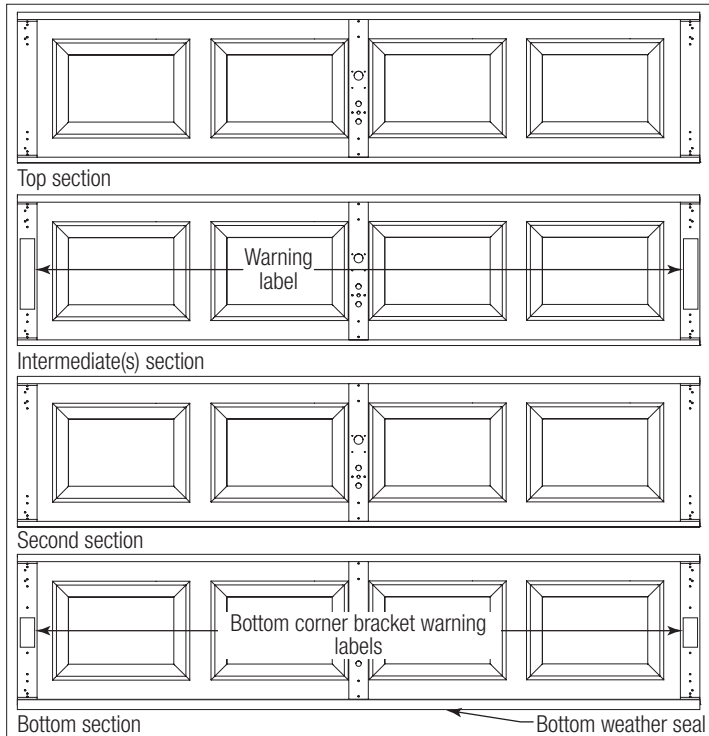

Figure 4

Tools Required

Personal Protection Equipment (PPE)



Figure 5

Hand Tools

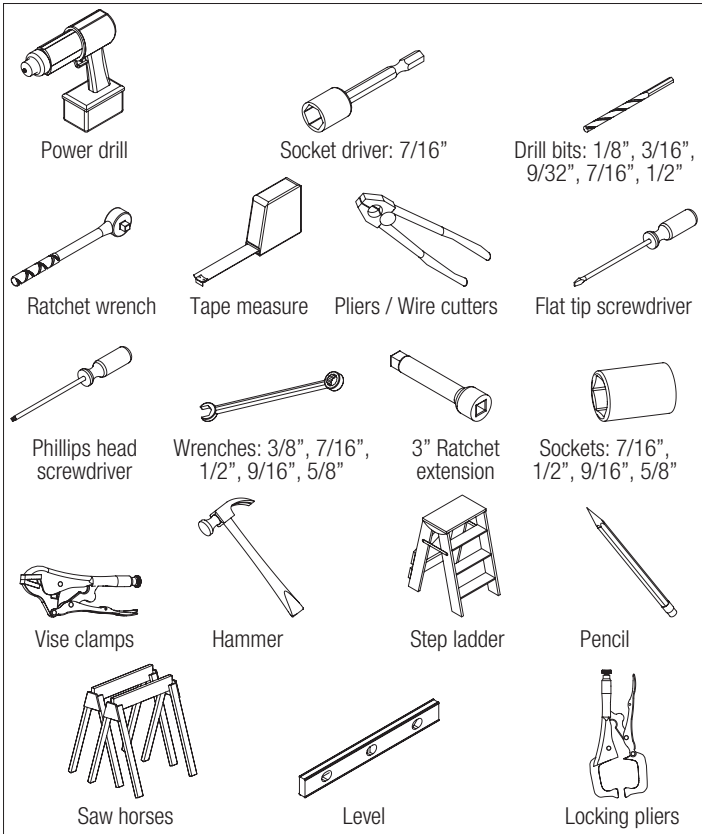

Figure 6

BREAKDOWN OF DOOR COMPONENTS

NOTE: The illustrations shown on this page are general representations of the door parts. Each specific door models may have unique variations.

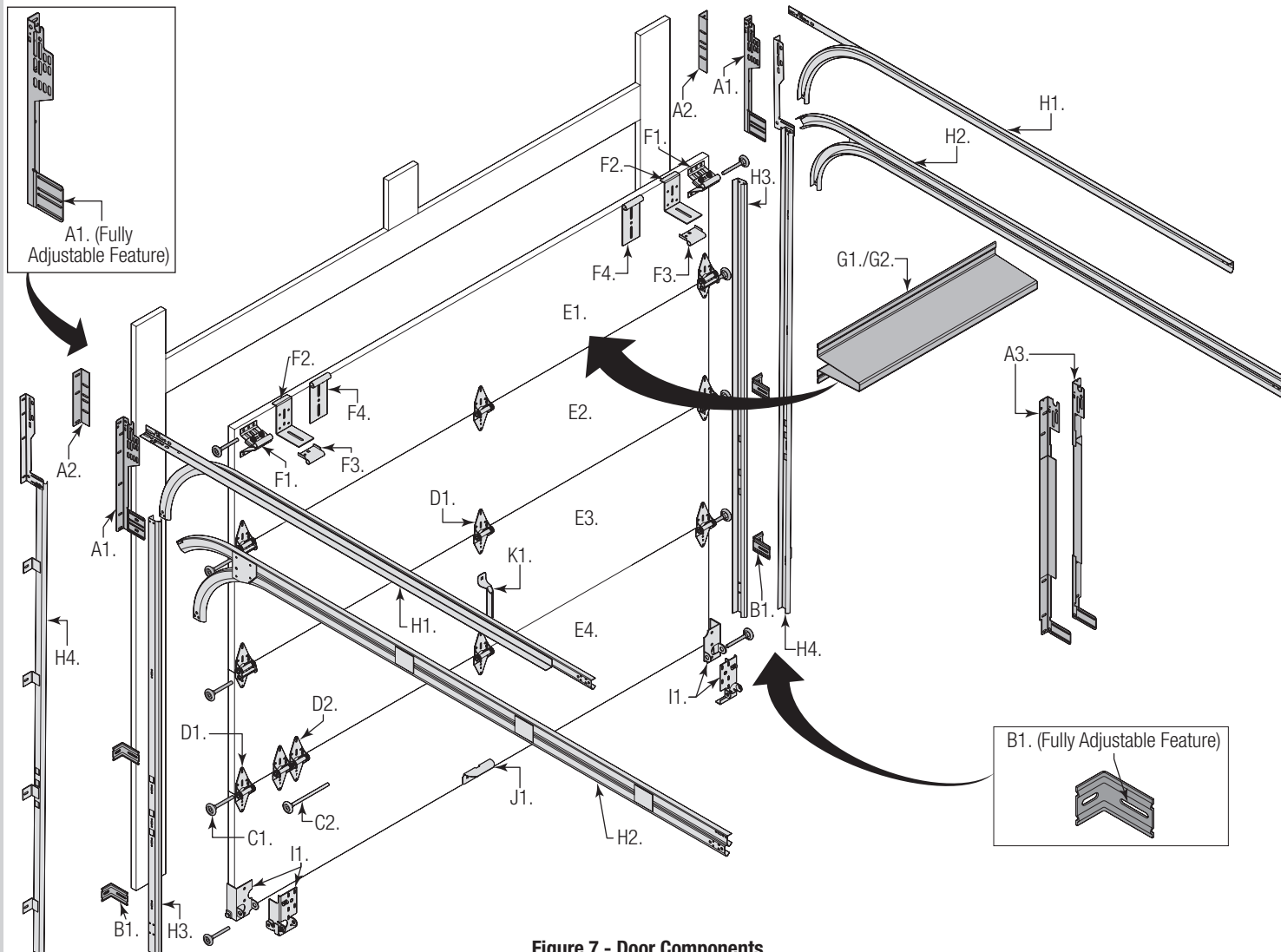

Figure 7 - Door Components

A. FLAG ANGLES (AS REQUIRED):

- A1. Fully Adjustable (F.A.) Flag Angles
- A2. Wall Clips
- A3. Flag Angles

B. JAMB BRACKETS (AS REQUIRED):

- B1. Fully Adjustable (F.A.) Jamb Brackets

C. TRACK ROLLERS (AS REQUIRED):

- C1. Short Stem Track Rollers
- C2. Long Stem Track Rollers

D. GRADUATED END HINGES:

- D1. Single Graduated End Hinges (S.E.H.), Industry Standard
- D2. Double Graduated End Hinges (D.E.H.), Industry Standard

E. STACKED SECTIONS:

- E1. Top Section
- E2. Intermediate(s) Section
- E3. Lock Section
- E4. Bottom Section

F. TOP FIXTURES (AS REQUIRED):

- F1. Top Fixture Assemblies

- F2. Top Fixture Bases
- F3. Top Fixture Slides
- F4. Top Fixtures

G. STRUT(S) (AS REQUIRED):

- G1. 2" Strut (U-shaped)
- G2. 3" Strut (U-shaped)

H. TRACKS (AS REQUIRED):

- H1. Left and Right Hand Horizontal Track Assemblies (For Standard Lift Applications)
- H2. Left and Right Hand Horizontal Track Assemblies (For Low Headroom Applications)
- H3. Left and Right Hand Vertical Tracks
- H4. Left and Right Hand Riveted Vertical Track Assemblies

I. BOTTOM CORNER BRACKETS (AS REQUIRED):

- I1. Left Hand And Right Hand Bottom Corner Brackets

J. STEP PLATES:

- J1. Step Plates

K. LIFT HANDLES:

- K1. Lift Handles

BREAKDOWN OF COUNTERBALANCE COMPONENTS

NOTE: The illustrations shown on this page are general representations of the door parts. Each specific door models may have unique variations.

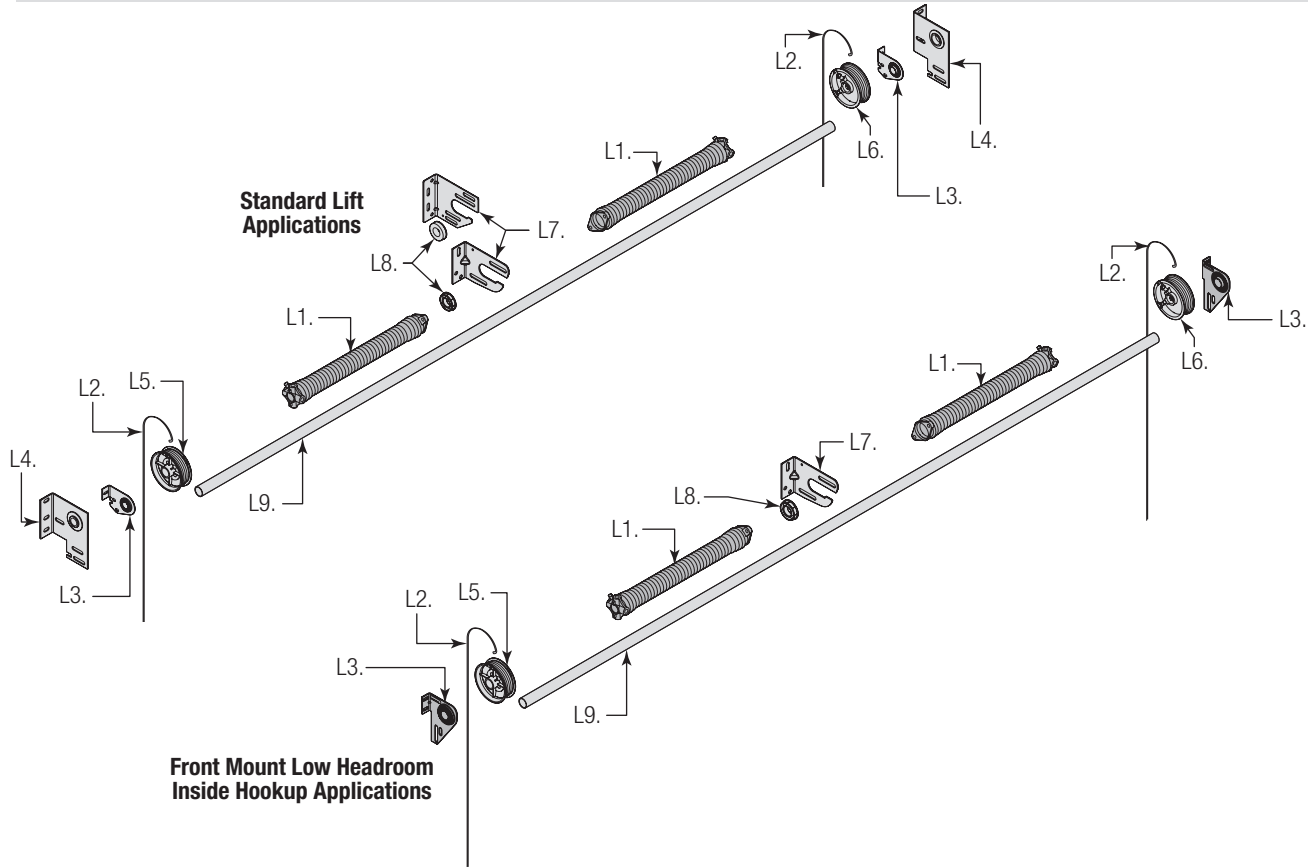

Figure 7 - Counterbalance Components

L. TORSION SPRING ASSEMBLY (AS REQUIRED):

- L1. Left Hand and Right Hand Torsion Springs (As Required)
- L2. Counterbalance Lift Cables
- L3. Left and Right Hand End Bearing Bracket (As Required)
- L4. Left and Right Hand End Bearing Bracket (As Required)
- L5. Left Hand Cable Drum
- L6. Right Hand Cable Drum
- L7. Center Bracket (As Required)
- L8. Center Bracket Bearing (As Required)
- L9. Torsion Shaft

INSTALLATION INSTRUCTIONS

Door Installation Instructions

BEFORE INSTALLING YOUR DOOR, BE CERTAIN THAT YOU HAVE READ AND FOLLOWED ALL OF THE INSTRUCTIONS COVERED IN THE PRE-INSTALLATION SECTION OF THIS MANUAL. FAILURE TO DO SO MAY RESULT IN AN IMPROPERLY INSTALLED DOOR.

IMPORTANT: Reference TDS 160 for general garage door terminology at www.dasma.com.

NOTICE

IF THE DOOR WILL BE EXPOSED TO A SIGNIFICANT AMOUNT OF ROAD SALT, PAINT THE BOTTOM GALVANIZED STEEL WEATHER RETAINER TO INHIBIT RUSTING.

1 SECTION SIZING

IMPORTANT: Refer to door section identification, located in the pre-installation section of this manual or refer to Breakdown of Parts.

WARNING

IT IS RECOMMENDED THAT A BREATHING APPARATUS BE WORN WHILE CUTTING DOWN THE FOAMED SECTIONS. FAILURE TO WEAR A BREATHING APPARATUS COULD RESULT IN A SEVERE INJURY.

WARNING

IT IS RECOMMENDED THAT GLOVES BE WORN WHILE HANDLING THE SECTIONS AND WORKING AROUND EXPOSED SHARP METAL EDGES. FAILURE TO WEAR GLOVES COULD RESULT IN A SEVERE INJURY.

NOTE: Not all doors will need to be cut down. If your door sections are the appropriate width for your opening, skip this step.

NOTE: End caps are marked right and left hand.

NOTE: A metal cutting finishing circular saw blade should be used when cutting the section width down to the appropriate width.

NOTE: When re-installing the endcaps back onto the section, you should use a metal, acrylic or epoxy adhesive, so the endcaps will adhere to the section surface.

IMPORTANT: It is highly recommended to protect the outside finish when laying the section onto the saw horses with carpet or equivalent material to prevent the section from being scratched or damaged.

NOTE: Typical section cut down is (Opening width minus 1/8", divided by 2).

WARNING

BEFORE CUTTING THE SECTION DOWN TO THE DESIRED WIDTH, ENSURE YOU ARE CUTTING BOTH SIDES EQUALLY. FAILURE TO DO SO COULD RESULT IN SECTION PANELING NOT LINING UP VERTICALLY.

See Figure 8 for the following steps.

- 1a. Lay the section ① face down onto saw horses ②.
- 1b. Using a phillips head screwdriver, remove but retain all screws ③ from both the left hand and the right hand end caps ④.
- 1c. Gently slide the end caps off of the section and set them aside.

1d. Locate the center of the section. Measure from the center of the section outward and mark a vertical line onto the section surface. On the opposite side, measure from the center of the section outward and mark another vertical line onto the section surface.

1e. Using a circular saw carefully cut section to the desired width.

1f. Starting on left hand side, apply some adhesive ⑤ to the inside section surface and position the left hand end cap onto the left hand side of the section.

1g. While holding the end cap in position, re-use the screws ③ to secure the end cap to the section.

1h. Repeat for the right hand side and then repeat the same process for the other sections.

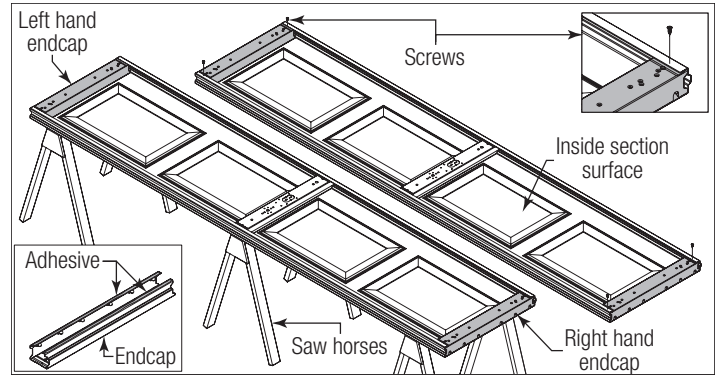

Figure 8

1	Section	4	End Caps
2	Saw Horses	5	Adhesive
3	Screws		

2 ATTACHING FLAG ANGLES AND JAMB BRACKETS TO VERTICAL TRACKS

IMPORTANT: If you have Riveted Track, skip this step.

IMPORTANT: The bottom jamb bracket is always the shortest bracket, while the center jamb bracket is the next tallest. If three jamb brackets per side are included with your door, you will have received a top jamb bracket, which is the tallest.

For Doors With Fully Adjustable Flag Angle:

See Figure 9 and Figure 10 for the following steps.

1a. Hand tighten the flag angle ① to the vertical track ② using two 1/4" - 20 x 9/16" track bolts ③ and two 1/4" - 20 flange hex nuts ④.

1b. attach the shortest jamb bracket ⑤ by aligning the slot in the shortest jamb bracket with the lower hole of the hole/ slot pattern of the vertical track. Hand tighten the jamb bracket using (1) 1/4" - 20 x 9/16" track bolt and (1) 1/4" - 20 flange hex nut.

1c. Place the tallest jamb bracket ⑥ over the lower hole of the hole/ slot pattern that is centered between the bottom jamb bracket and flag angle of the 2nd hole set. Hand tighten the jamb bracket using (1) 1/4" - 20 x 9/16" track bolt and (1) 1/4" - 20 flange hex nut.

1d. Repeat this process for the right hand side.

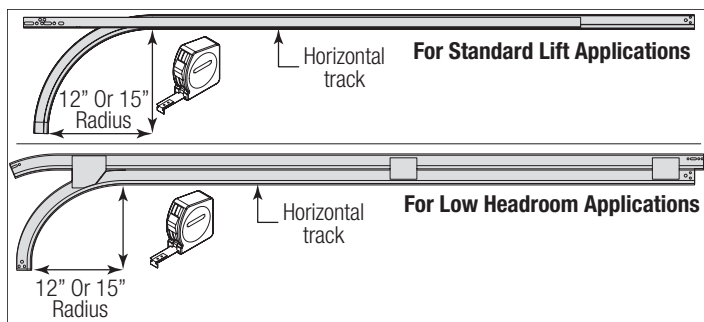

Figure 9, Left Side Shown

IMPORTANT: In Figure 10, observe the slot location in reference to the 12\"/>

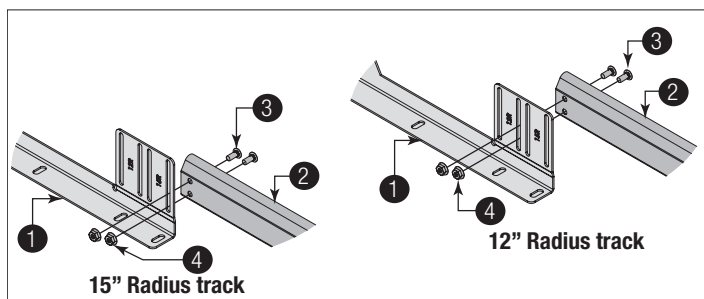

Figure 10, Left Side Shown

1	Flag Angle	4	1/4\"/>
2	Vertical Track	5	Shortest Jamb Bracket
3	1/4\"/>		
6	Tallest Jamb Bracket		

3 ATTACHING BOTTOM CORNER BRACKETS

IMPORTANT: Refer to door section identification, located in the pre-installation section of this manual or refer to Breakdown of Parts.

! WARNING

ENSURE TIGHT FIT OF CABLE LOOP OVER PIN TO PREVENT COUNTERBALANCE LIFT CABLE FROM COMING OFF THE PIN, WHICH COULD ALLOW THE DOOR TO FALL AND RESULT IN DEATH OR SERIOUS INJURY.

IMPORTANT: Verify bottom weather seal 2 is aligned with bottom section 1. If there is more than 1/2\"/>

IMPORTANT: Refer to Package Contents / Breakdown of Parts, to determine which bottom corner brackets you have.

See Figure 11 through Figure 13 for the following steps.

3a. Uncoil the counterbalance lift cables 3.

3b. Depending on which bottom corner brackets 4 you have, slip the cable loop 5 at the ends of the counterbalance lift cable over the milford pin 6 of the bottom corner bracket or secure the cable loop to the clevis pin 8 and bottom corner bracket using a flat washer 7 and a cotter pin 9. Repeat this process for the opposite side.

3c. Starting on the left hand side, attach the left hand bottom corner bracket to the left corner of the bottom section, making sure it is seated to the edges of the end cap 10, using three 1/4\"/>

3d. Insert a short stem track roller 13 with roller spacer 14 into the bottom corner brackets.

IMPORTANT: The 1/4\"/>

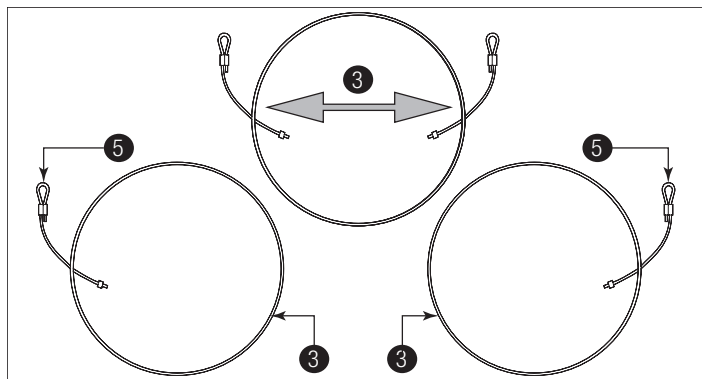

Figure 11

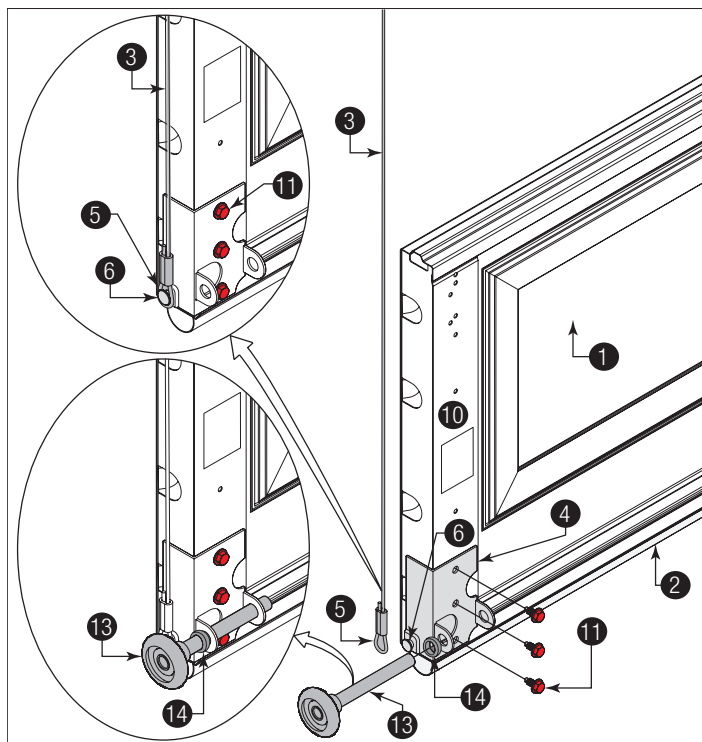

Figure 12, Left Side Shown

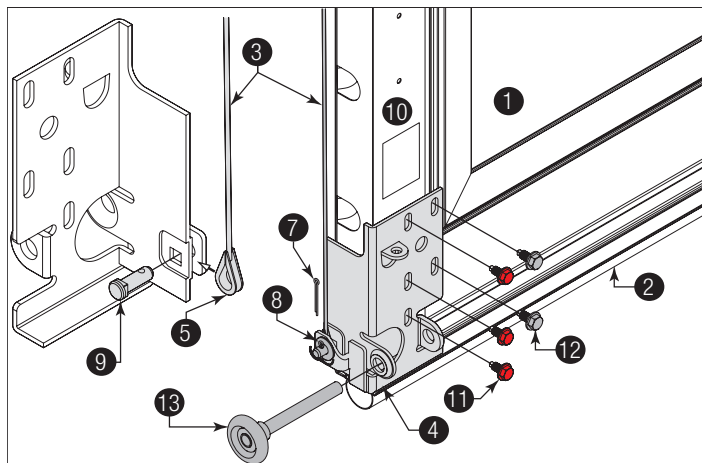

Figure 13, Left Side Shown

1	Bottom Section	8	Flat Washer
2	Bottom Weather Seal	9	Cotter Pin
3	Counterbalance Lift Cable	10	End Cap
4	Bottom Corner Bracket	11	1/4" - 20 x 11/16" RED HEAD Self drilling screws
5	Cable Loop	12	1/4" - 20 x 11/16" Self drilling screws
6	Milford Pin	13	Short Stem Track Roller
7	Clevis Pin	14	Roller Spacer

4 ATTACHING HINGES TO SECTIONS

NOTE: Refer to door section identification, located in the pre-installation section of this manual or refer to Breakdown of Parts.

NOTE: The graduated hinges ① can be identified by the number stamped on the lower hinge leaf.

NOTE: The #1 graduated hinges ② serves as end hinges on the bottom section ⑦. The #1 graduated hinges also serves as center hinges on all sections, except for the top section.

NOTE: The #2 graduated hinges ③ serves as end hinges on the Second section ⑬.

NOTE: The #3 graduated hinges ④ serves as end hinges on the Intermediate section I ⑭.

NOTE: The #4 graduated hinges ⑤ serves as end hinges on the Intermediate section II ⑮.

NOTE: The #5 graduated hinges ⑥ serves as end hinges on the Intermediate section III ⑯.

See Figure 14 through Figure 17 for the following steps.

4a. Starting on the left hand side of the bottom section, align the lower hinge leaf of the #1 graduated hinge over the holes, located at the top of the end stile ⑧. Attach lower leaf to the end stile with (2) 1/4" - 14 x 5/8" self tapping screws ⑨.

4b. Repeat same process for the right hand side.

4c. Next, align the lower hinge leaf of the #1 center hinges with the pre-punched holes at each center stile location(s) ⑩, located at the top of the bottom section. Attach lower hinge leaf to the center stile with (2) 1/4" - 14 x 5/8" self tapping screws.

IMPORTANT: Once the 1/4" - 14 x 5/8" self tapping screws are snug against the lower hinge leaves, tighten an additional 1/4 to 1/2 turn to receive maximum design holding power.

4d. Insert a short stem track roller ⑪ into the hinge tube of the #1 graduated end hinges.

4e. Repeat graduated hinge attachment using the appropriate graduated hinges for all remaining sections except the top section.

IMPORTANT: When placing short stem track rollers into the #2 graduated end hinges and higher, the short stem track roller goes into hinge tube ⑫ furthest away from section.

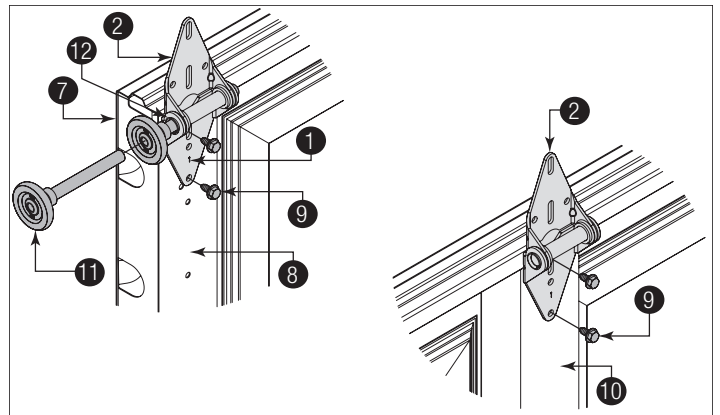

Figure 14

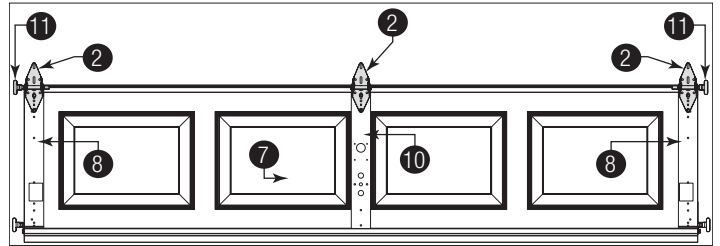

Figure 15

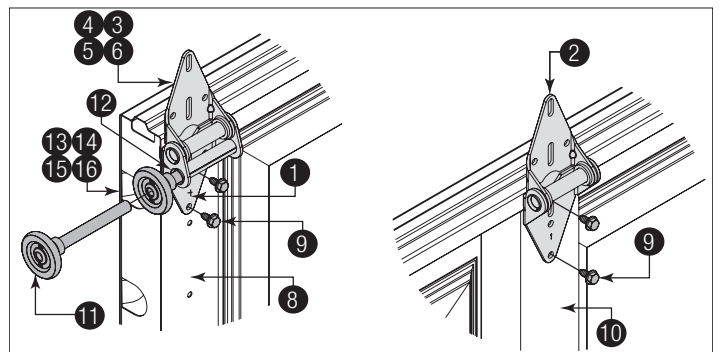

Figure 16

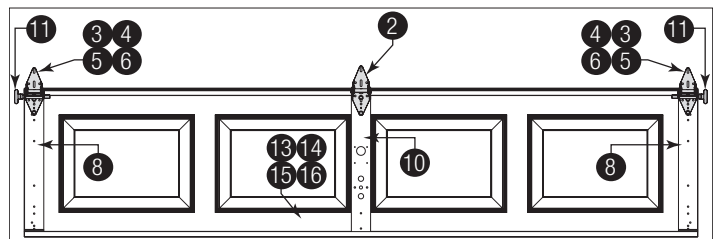

Figure 17

1	Graduated Hinges	9	1/4" - 14 x 5/8" Self Tapping Screws
2	#1 Graduated Hinges	10	Center Stile(s)
3	#2 Graduated Hinges	11	Short Stem Track Roller
4	#3 Graduated Hinges	12	Hinge Tube
5	#4 Graduated Hinges	13	Second Section
6	#5 Graduated Hinges	14	Third (Int I) Section
7	Bottom Section	15	Fourth (Int II) Section
8	End Stile	16	Fifth (Int III) Section

5 ATTACHING TOP FIXTURES TO TOP SECTION

NOTE: Refer to Package Contents or Breakdown of Parts to determine if you have Top Fixture Assemblies, Top Fixture Bases and Top Fixture Slides or Top Fixtures.

NOTE: The top fixture slide will be tightened and adjusted later, in "Adjusting Top Fixtures" step.

IMPORTANT: Ensure the top fixture slide **1** is able to slide along the top fixture base **2**. If needed, loosen the 1/4" - 20 flange hex nuts **3** or the 5/16" hex nuts **4**.

If You Have Top Fixture Assemblies:

See Figure 18 for the following steps.

5a. Starting on the left hand side, align the upper-center hole **5** of top fixture base with the hole in the end cap **6** of the top section **7** and even with the edge of the top section.

5b. Fasten to section using (4) 1/4" - 20 x 11/16" self drilling screws **8**.

5c. Insert short stem track roller **9** into top fixture slide.

5d. Repeat same process for the right hand side.

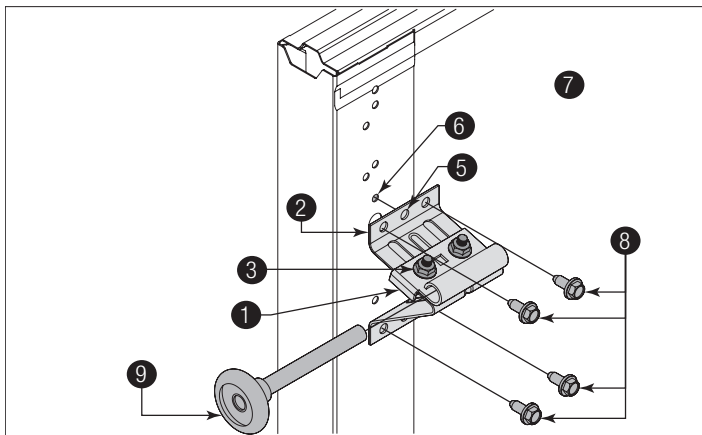

Figure 18

1	Top Fixture Slide	6	End Cap
2	Top Fixture Base	7	Top Section
3	1/4" - 20 Flange Hex Nuts	8	1/4" - 20 x 11/16" Self Drilling Screw

4	5/16" Hex Nut	9	Short Stem Track Roller
5	Upper-Center Hole		

If You Have Top Fixture Bases And Top Fixture Slides:

See Figure 19 for the following steps.

5a. Starting on the left hand side, align the top fixture base **2** on top of the corner of the top section **7** and even with the edge of the section.

5b. Fasten to section through end cap **6** using four 1/4" - 20 x 11/16" self drilling screws **8**.

5c. Loosely secure the top fixture slide **1** to the top fixture base using one 5/16" - 18 x 3/4" carriage bolt **10** and (1) 5/16" - 18 hex nut **4**.

5d. Insert short stem track roller **9** into top fixture slide.

5e. Repeat same process for other right hand side.

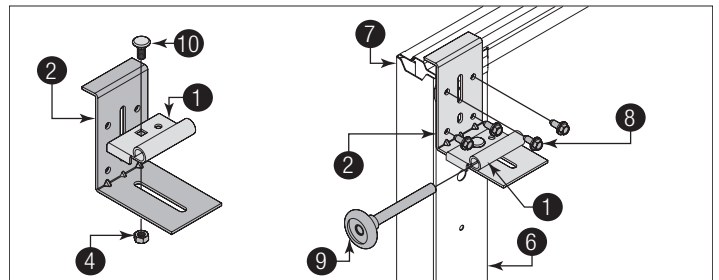

Figure 19

1	Top Fixture Slide	7	Top Section
2	Top Fixture Base	8	1/4" - 20 x 11/16" Self Drilling Screw
4	5/16" Hex Nut	9	Short Stem Track Roller
6	End Cap	10	5/16" - 18 x 3/4" Carriage Bolt

If You Have Top Fixtures:

See Figure 20 for the following steps.

5a. Starting on the left hand side, align the lower slot of top fixture **11** with the hole in the end cap **6** of the top section **7** and even with the edge of the top section.

5b. Fasten to section using a 1/4" - 20 x 11/16" self drilling screw **8**.

5c. Insert short stem track roller **9** into top fixture.

5d. Repeat same process for other right hand side.

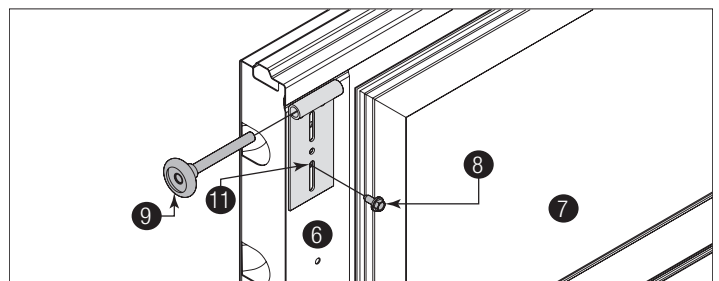

Figure 20

6	End Cap	9	Short Stem Track Roller
7	Top Section	11	Top Fixture
8	1/4" - 20 x 11/16" Self Drilling Screw		

6 ATTACHING STRUT TO SECTIONS

NOTE: Refer to door section identification, located in the pre-installation section of this manual or refer to Breakdown of Parts.

IMPORTANT: If you completed Step "Section Sizing", then the struts will have to be cut down the same amount as the sections or Door Section Width - 1" for the strut length.

IMPORTANT: All struts ① are placed at the top of the sections and up against the bottom of hinges ②, for the Bottom Section ③, Lock (Second) Section ④, and Intermediate Section(s) ⑤ ⑥.

IMPORTANT: Measure the height of your strut(s) to determine if you have 2" Struts ⑦ and or 3" Struts ⑧. See Figure 21.

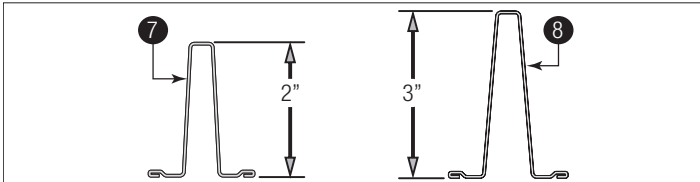

Figure 21

IMPORTANT: Referencing the strutting schedules below, determine the placement of the struts for your door width and door height.

Strutting Schedule Key:

TS = Top Section	I2 = Intermediate Section #2	BS = Bottom Section
IW = Intermediate Section With Windows	I1 = Intermediate Section #1	ES = Every Section gets a strut
I3 = Intermediate Section #3	LS = Lock Section	RS = Remaining Sections gets a strut

Strutting Schedule For Model 8000

Door Heights	Section Qty	Section Type	Door Widths		
			14'0" - 16'11"	17'0" - 18'11"	20'0"
6'0" - 7'0"	4	Solid	(1) TS	(3) TS, LS, BS	ES
		Windows	(1) TS	(1) 3" TS, (2) 2" LS, BS	ES
7'6" - 8'9"	5	Solid	(2) TS, BS	(3) TS, I1, BS	ES
		Windows	(1) 3" TS, (1) 2" BS	(1) 3" TS, (2) 2" I1, BS	ES
9'0"	6	Solid	(5) TS, I3, I2, I1, BS	ES	N/A
		Windows	(1) 3" TS, (4) 2" I3, I2, I1, BS	(1) 3" TS, (5) 2" RS	N/A

Strutting Schedule For Model 8200

Door Heights	Section Qty	Section Type	Door Widths		
			14'0" - 16'11"	17'0" - 18'11"	20'0"
6'0" - 7'0"	4	Solid	(2) TS, BS	(3) TS, LS, BS	ES
		Windows	(1) 3" TS, (1) 2" BS	(1) 3" TS, (2) 2" LS, BS	ES
7'6" - 8'0"	5	Solid	(2) TS, BS	(3) TS, I1, BS	ES
		Windows	(1) 3" TS, (1) 2" BS	(1) 3" TS, (2) 2" I1, BS	ES
8'3" - 8'9"	5	Solid	(2) TS, BS	(3) 2" TS, I1, BS	N/A
		Windows	(1) 3" TS, (1) 2" BS	(1) 3" TS, (2) 2" I1, BS	N/A
9'0"	6	Solid	(5) TS, I3, I2, I1, BS	ES	N/A
		Windows	(1) 3" TS, (4) 2" I3, I2, I1, BS	(1) 3" TS, (5) 2" RS	N/A

Attaching Strut To Sections:

See Figure 22 for the following steps.

6a. Locate and center the strut onto the bottom section ③ surface and up against the bottom of hinges, as shown. Center the strut from side to side.

6b. Secure strut to the section surface using (2) 1/4" - 20 x 1" self drilling screws ⑨ at each end stiles ⑩ and at each center stile ⑪.

6c. Repeat the same process all remaining sections, except the top section.

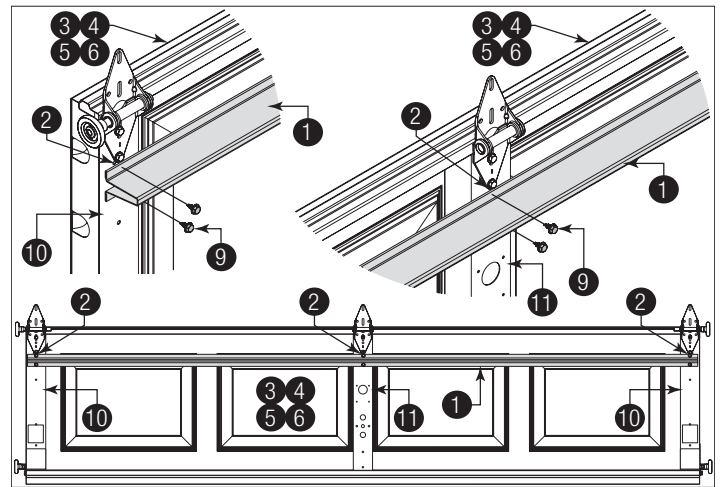

Figure 22

Attaching Strut To Top Section:

See Figure 23 for the following steps.

6d. Locate and center the strut onto the top of the top section surface ⑫, as shown.

6e. Secure strut to the top section using (2) 1/4" - 20 x 1" self drilling screws ⑨ at each end stiles ⑩ and at each center stile ⑪.

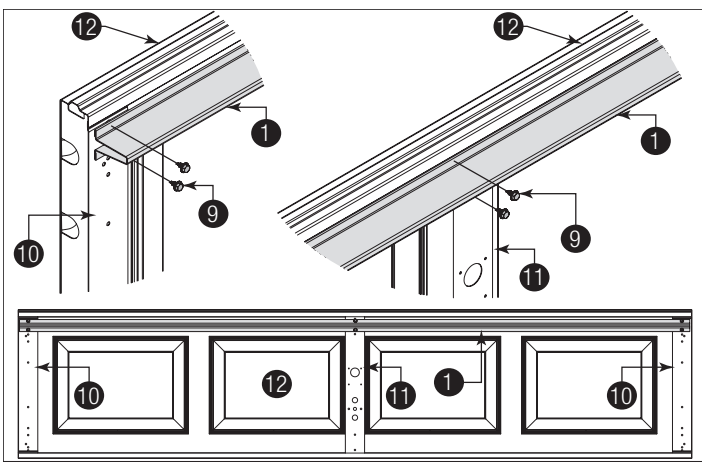

Figure 23

1	Strut	7	2" Strut
2	Bottom Of Hinges	8	3" Strut
3	Bottom Section	9	1/4" - 20 x 1" Self Drilling Screws
4	Second Section	10	End Stiles
5	Third (Int I) Section	11	Center Stile(s)
6	Fourth (Int II) Section	12	Top Section

7 ATTACHING STEP PLATES TO SECTION

IMPORTANT: Do not mount the step plate higher than 6" (1) from the bottom of the section (2).

See Figure 24 for the following steps.

- 7a. Locate the center most center stile (3) of the bottom section of the door.
- 7b. On the inside of the door (4), center the step plate (5) on the center most stile no higher than 6" from the bottom of the door.
- 7c. Using the step plate holes as a template, drill a 5/16" dia. hole (6) along each side of the center stile, through the face of the door (7).

IMPORTANT: Be extremely careful to keep drill straight.

- 7d. Mount the inside step plate and the outside step plate back to back, straddling the center stile. Secure with (2) 1/4" - 20 x 2-3/4" carriage bolts (8) and 1/4" - 20 hex nuts (9).

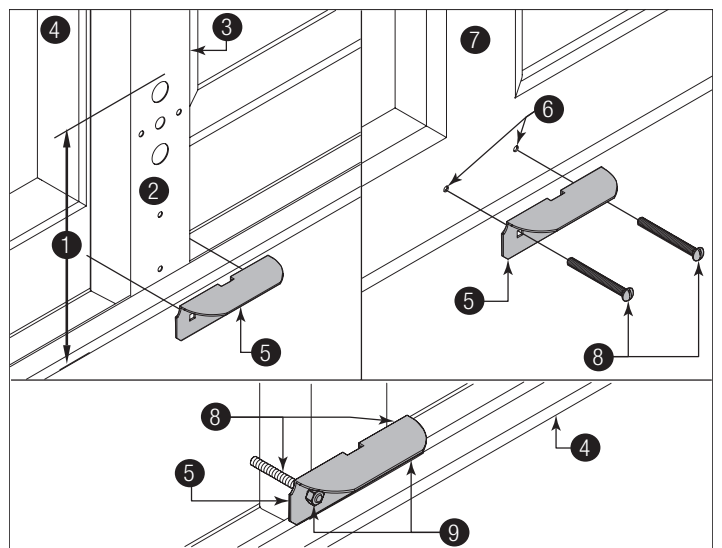

Figure 24

1	6"	6	5/16" Dia. Holes
2	Bottom Section	7	Face Of The Door
3	Center Stile	8	1/4" - 20 x 2-3/4" Carriage Bolts
4	Inside Of The Door	9	1/4" - 20 Hex Nuts
5	Step Plate		

8 ATTACHING LIFT HANDLES TO SECTION

NOTE: Doors with a Keyed lock do not require this lift handle.

See Figure 25 through Figure 27 for the following steps.

- 8a. Locate the inside center stile or the desired lift handle location (1) on the second section (2) of the door. Position the lower hole in the lift handle (3) 4" (4) from the bottom of the second section.

IMPORTANT: The distance between the step plate (5) and the middle of the lift handle must be 20" minimum to 30" maximum (6). If necessary, reposition the upper lift handle to stay within the required dimension.

- 8b. Using the lift handle holes as a template, drill (2) 9/32" dia. holes (7) through the second section. Enlarge the holes from the outside the door to 1/2" dia (8).

IMPORTANT: Be extremely careful to keep drill straight.

IMPORTANT: Do not drill through or enlarge holes on the inside of the door.

- 8c. Assemble the lift handles to the second section using (2) spacers (9), (2) 1/4" - 20 x 2-1/2" carriage bolts (10), and (2) 1/4" - 20 hex nuts (11).

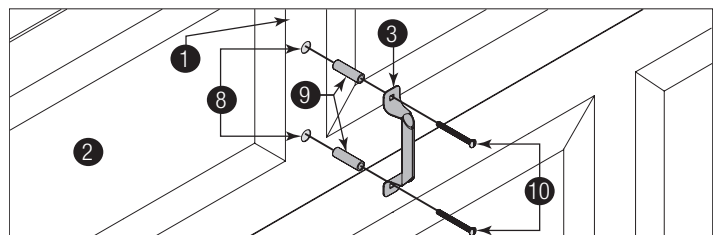

Figure 25

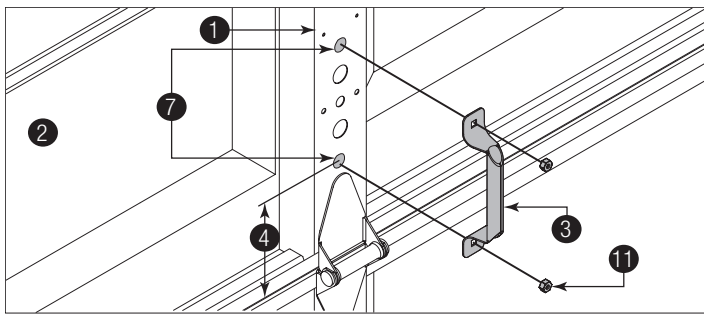

Figure 26

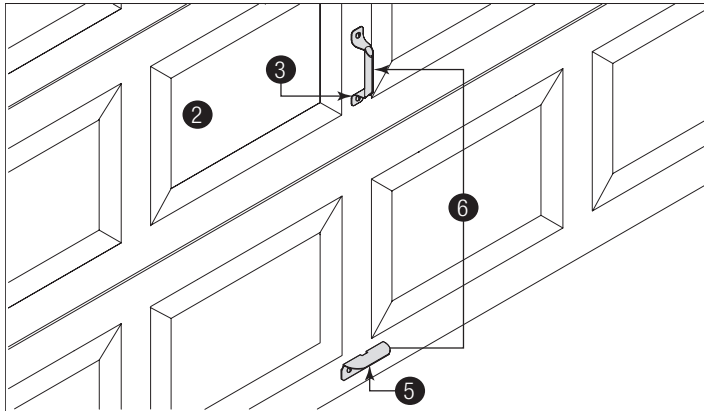

Figure 27

1	Inside Center Stile Or Desired Lift Handle Location	7	9/32" Dia. Holes
2	Second Section	8	1/2" Dia
3	Lift Handle	9	Spacers
4	4"	10	1/4" - 20 x 2-1/2" Carriage Bolts
5	Step Plate	11	1/4" - 20 Hex Nuts
6	20" Minimum To 30" Maximum		

9 POSITIONING BOTTOM SECTION

See Figure 28 for the following steps.

9a. Center the bottom section 1 in the door opening.

9b. Use a level 2 and wood shims 3 (if necessary) to level the bottom section. When the bottom section is leveled, temporarily hold it in place by driving a nail into the jamb and bending it over the edge of the bottom section on both sides.

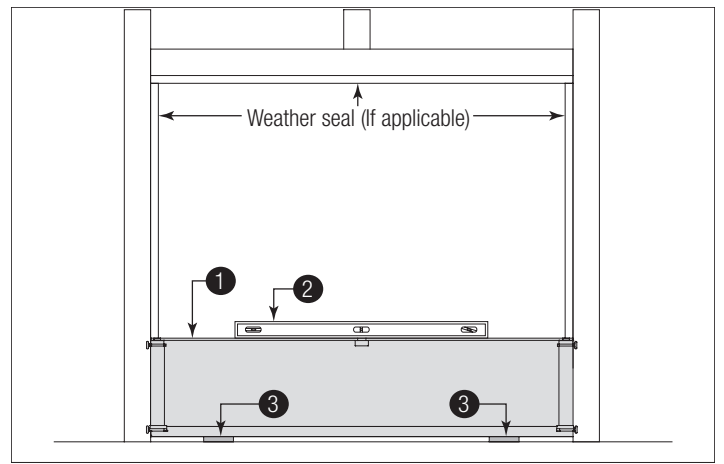

Figure 28

1	Bottom Section	3	Wood Shims
2	Level		

10 ATTACHING VERTICAL TRACKS TO JAMBS

IMPORTANT: Depending on your door, you may have Fully Adjustable Flag Angles or you may have Riveted Vertical Track Assemblies. Refer to Package Contents / Breakdown of Parts, to determine which Flag Angles / Vertical Track Assemblies you have.

IMPORTANT: If this door is to be installed prior to a finishing construction of the building's floor, the vertical tracks and the door bottom section assembly should be installed such that when the floor is constructed, no door or track parts are trapped in the floor construction.

IMPORTANT: If the bottom section was leveled with shims, the vertical track on the shimmed side must be raised the same height as the shim. Recheck the top of the vertical tracks to be level from side to side.

IMPORTANT: Make sure the counterbalance lift cable is located between the track rollers and the door jamb.

See Figure 29 and Figure 30 for the following steps.

10a. Starting on the left hand side of the bottom section 1, remove the nail. Position the left hand vertical track assembly 2 over the track rollers of the bottom section and install, as shown. Drill 3/16" pilot holes into the door jamb for the lag screws.

IMPORTANT: For proper flag angle lag screw location, note the flag angle styles 3.

For Doors With Fully Adjustable Flag Angles:

10b. Loosely fasten jamb brackets 4 and flag angle 5 to the jamb using 5/16" x 1-5/8" lag screws 6.

10c. Tighten lag screws, securing the bottom jamb bracket to jamb, maintain 3/8" to 5/8" spacing 7, between the bottom section and vertical track.

10d. Hang counterbalance lift cable over flag angle. Repeat same process for other side.

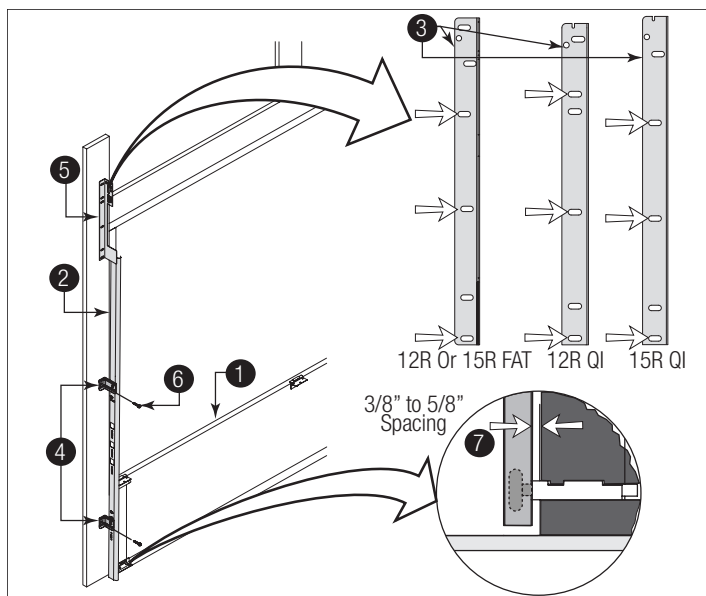

Figure 29, Left Side Shown

For Doors With Riveted Vertical Track Assemblies:

10b. Loosely fasten jamb brackets 4 and flag angle 5 to the jamb using 5/16" x 1-5/8" lag screws 6.

10c. Tighten lag screws, securing the bottom jamb bracket to jamb, maintain 3/8" to 5/8" spacing 7 as shown, between the bottom section and vertical track.

10d. Hang counterbalance lift cable over flag angle. Repeat same process for other side.

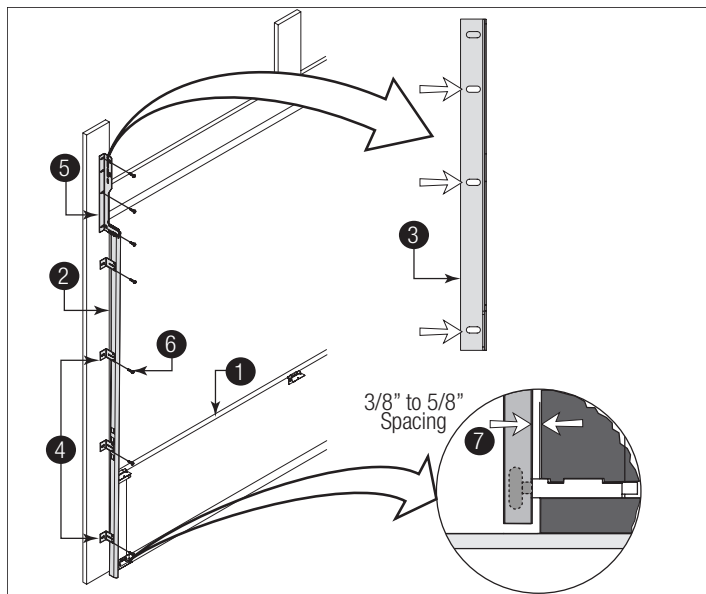

Figure 30, Left Side Shown

1	Bottom Section	5	Flag Angle
2	Vertical Track Assembly	6	5/16" x 1-5/8" Lag Screws
3	Flag Angle Styles	7	3/8" to 5/8" Spacing
4	Jamb Brackets		

NOTICE

BEFORE STACKING SECTIONS, MAKE SURE GRADUATED END AND CENTER HINGES ARE FLIPPED DOWN 1 TO AVOID POSSIBLE DAMAGE TO YOUR DOOR, WHEN STACKING ANOTHER SECTION ON TOP.

See Figure 31 and Figure 32 for the following steps.

- 11a. Install track rollers into graduated end hinges of remaining sections.
- 11b. With a helper, lift second section 2 and guide the track rollers into the vertical tracks 3. Lower section until it is seated against bottom section.
- 11c. Flip hinges up 4. Fasten center hinge(s) 6 first; then end hinges 5 7 last using 1/4" - 14 x 5/8" self-tapping screws 8.
- 11d. Repeat same process for other sections, except top section.

IMPORTANT: Push & hold the hinge leafs securely against the sections while securing with fasteners to it. There should be no gap between the hinge leaves and the sections.

IMPORTANT: When placing the track rollers into the #2 graduated end hinges and higher, the track roller goes into the hinge tube furthest away from the section.

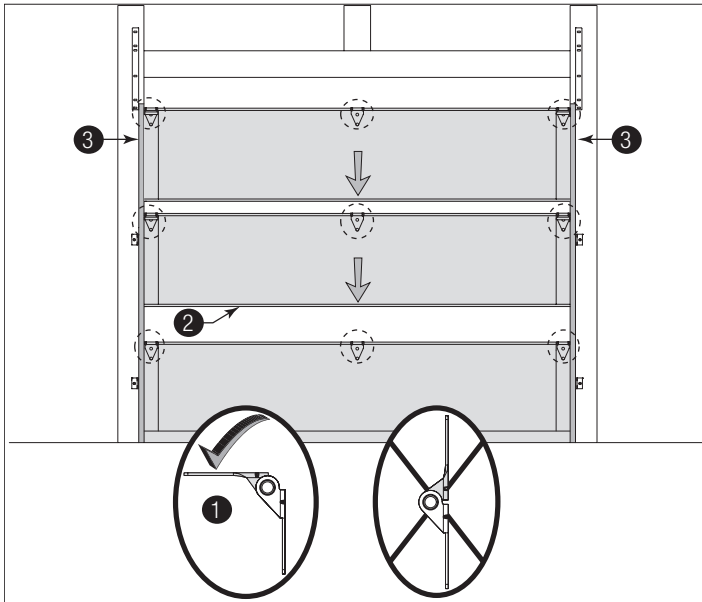

See Figure 31, Stacking Sections

1	Hinge Flipped Down Position	3	Vertical Tracks
2	Second Section		

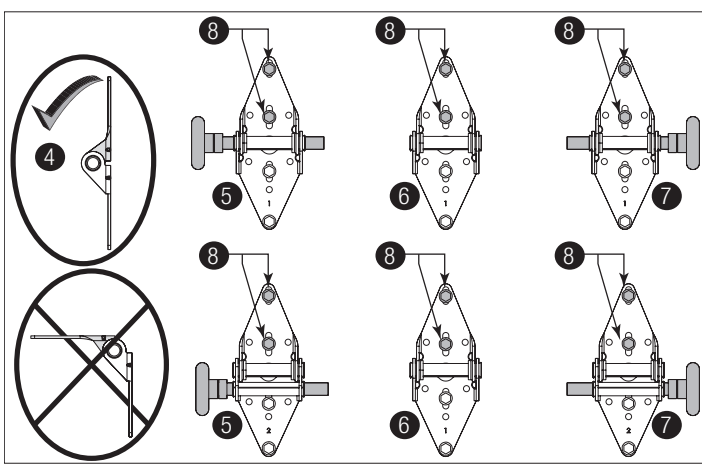

See Figure 32, Hinges after Stacking Sections

11 STACKING SECTIONS

NOTE: Refer to door section identification, located in the pre-installation section of this manual or refer to Breakdown of Parts.

4	Hinge Flipped Up Position	7	Right Graduated End Hinge with Short Stem Track Roller
5	Left Graduated End Hinge with Short Stem Track Roller	8	1/4" - 14 x 5/8" Self Tapping Screw Locations
6	Center Hinge(s)		

NOTE: Depending on your door, you may have Fully Adjustable Flag Angles or you may have Riveted Vertical Track Assemblies. Refer to Package Contents / Breakdown of Parts, to determine which Flag Angles / Vertical Track Assemblies you have.

NOTE: Refer to Package Contents / Breakdown of Parts, to determine which horizontal tracks you have.

NOTE: Pilot drill all 5/16" x 1-5/8" lag screws using a 3/16" drill bit, prior to fastening.

! WARNING

DO NOT RAISE DOOR UNTIL HORIZONTAL TRACKS ARE SECURED AT REAR, AS OUTLINED IN STEP, ATTACHING REAR BACK HANGS. THE REAR BACK HANGS OR DOOR COULD FALL FROM OVERHEAD POSITION CAUSING DEATH OR SERIOUS INJURY.

If You Have A 12" Or 15" Horizontal Track:

See Figure 34 for the following steps.

13a. Place the curved end of the horizontal track ① over the top track roller of the top section.

13b. Attach the horizontal track to the flag angle ② with two 1/4" - 20 x 9/16" track bolts ③ and two 1/4" - 20 flange hex nuts ④.

13c. Level ⑤ the horizontal track assembly and bolt the horizontal track angle ⑥ to the first encountered slot in the flag angle using one 3/8" - 16 x 3/4" truss-head bolt ⑦ and one 3/8" - 16 hex nut ⑧.

13d. Repeat for right side.

12 STACKING TOP SECTION

IMPORTANT: The dimension between the flag angles ① must be door width plus 3-3/8" - 3-1/2" (86 mm - 89 mm).

See Figure 33 for the following steps.

12a. Place the top section ② in the opening, on top of the section stacked.

12b. Install a nail ③ to temporarily hold the top section.

12c. Flip up the hinge leaves, hold tight against section, and fasten center hinges first and end hinges last (see Stacking Sections).

12d. Position flag angle ④ between 1-11/16" to 1-3/4" (43 mm - 44 mm) from the edge of the door ⑤, then tighten the bottom lag screw. Flag angles must be parallel to the door sections. Repeat for other side.

12e. Complete the vertical track ⑦ installation. **Secure** the jamb bracket(s) and tightening the other lag screws. Push the vertical track against the track rollers so that the track rollers are touching the deepest part of the curved side of the track; tighten all the track bolts and nuts. Repeat for other side.

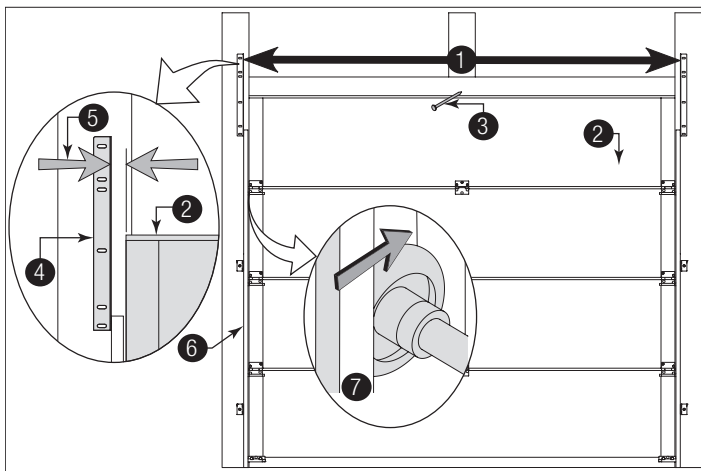

Figure 33

1	Clearance Measurement Between Both Flag Angles	5	Clearance Measurement Between Flag Angle and Door Edge
2	Top Section	6	Vertical Track
3	Nail	7	Vertical Track Against Track Rollers
4	Flag Angle		

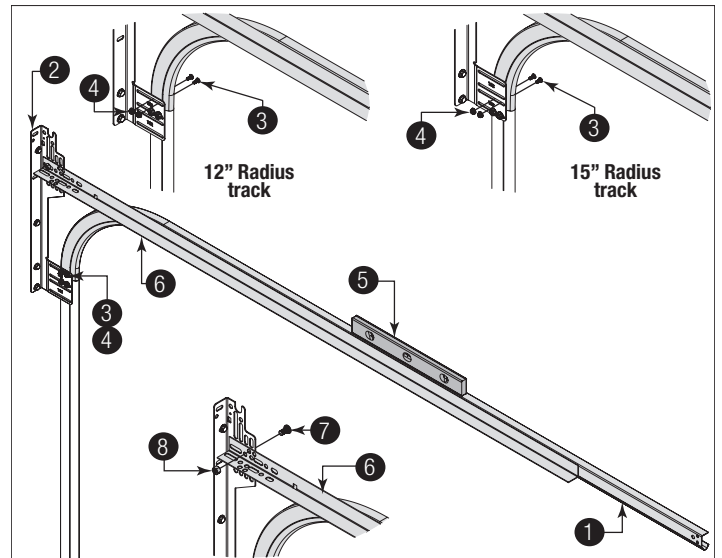

Figure 34, Left Side Shown

1	Horizontal Track	5	Level
2	Flag Angle	6	Horizontal Track Angle
3	1/4" - 20 x 9/16" track bolts	7	3/8" - 16 x 3/4" Truss-Head Bolt
4	1/4" - 20 flange hex nuts	8	3/8" - 16 Hex Nut

If You Have A 32" Horizontal Track:

See Figure 35 for the following steps.

13a. Loosely attach the horizontal track angle ⑥ to the second hole of the wall clip ⑨ using one 3/8" - 16 x 3/4" truss head bolt ⑦ and one 3/8" - 16 hex nut

13 ATTACHING HORIZONTAL TRACKS

8.

13b. Attach the horizontal curve to the upper slots in the flag angle **2** using two 1/4" - 20 x 9/16" track bolts **3** and two 1/4" - 20 flange hex nuts **4**. Rotate the horizontal track **1** upward until the track assembly is approximately level **5** with the floor.

13c. Attach the wall clip to the jamb using two 5/16 x 1-5/8" lag screws **10**.

13d. Level the horizontal track and tighten the 3/8" - 16 x 3/4" truss head bolt and the 3/8" - 16 hex nut. Repeat same process for other side.

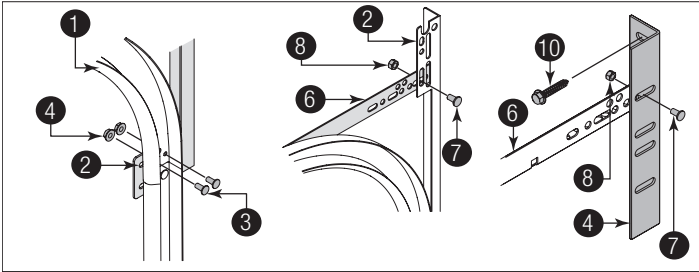

Figure 35, Left Side Shown

1	Horizontal Track	6	Horizontal Track Angle
2	Flag Angle	7	3/8" - 16 x 3/4" Truss-Head Bolt
3	1/4" - 20 x 9/16" track bolts	8	3/8" - 16 Hex Nut
4	1/4" - 20 flange hex nuts	9	Wall Clip
5	Level	10	5/16 x 1-5/8" Lag Screw

If You Have Low Headroom Horizontal Track:

See Figure 36 and Figure 37 for the following steps.

13a. Place upper rail of horizontal track **1** over the top track roller of the top section.

13b. Attach lower rail of the horizontal track to the flag angle **2** with two 1/4" - 20 x 9/16" track bolts **3** and two 1/4" - 20 flange hex nuts **4**.

13c. Level **5** the horizontal track assembly and bolt the upper rail of the horizontal track to the encountered slot in the flag angle using one 1/4" - 20 x 9/16" track bolt, one 1/4" - 20 flange hex nut and one 5/16" washer **11**. Repeat same process for other side.

13d. Repeat for right side.

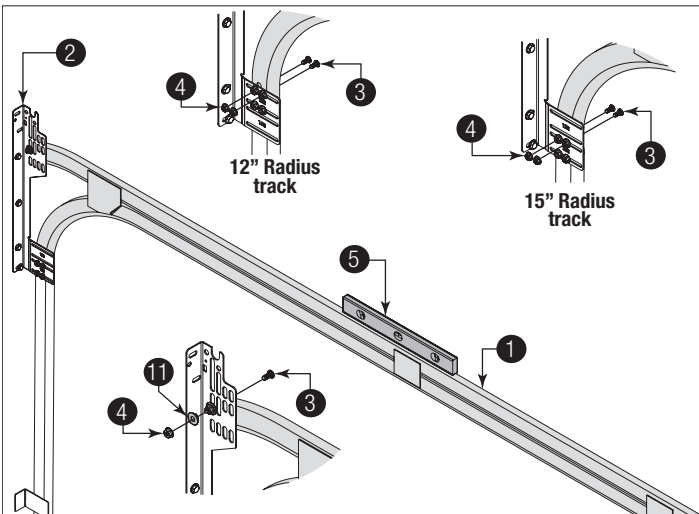

Figure 36, Left Side Shown

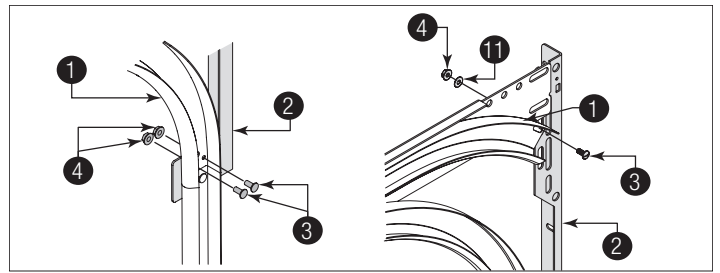

Figure 37, Left Side Shown

1	Horizontal Track	4	1/4" - 20 flange hex nuts
2	Flag Angle	5	Level
3	1/4" - 20 x 9/16" track bolts	11	5/16" washer

13e. When complete, remove the nail that was holding the top section in position.

NOTICE

FAILURE TO REMOVE NAIL BEFORE ATTEMPTING TO RAISE DOOR COULD CAUSE PERMANENT DAMAGE TO TOP SECTION.

14 ADJUSTING TOP FIXTURES

For Standard Lift Applications:

See Figure 38 and Figure 39 for the following steps.

14a. Vertically align the top section **1** of the door with the lower sections. Position the top fixture slide **2** with a track roller **5** out against the horizontal track **6**.

14b. Maintaining the slide's position, tighten the (2) 1/4" - 20 flange hex nuts or the 5/16" - 18 hex nut **3** to secure the top fixture slide to the top fixture base **4**.

14c. Repeat for right side.

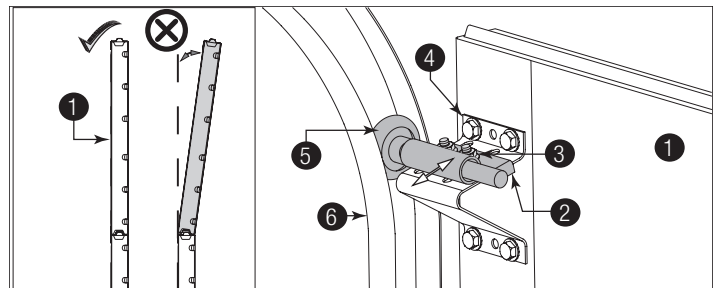

See Figure 38, Left Side Shown

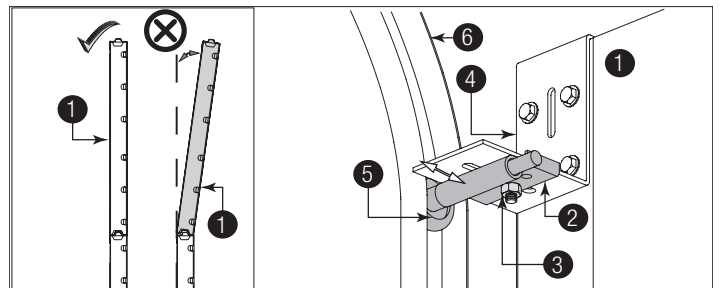

See Figure 39, Left Side Shown

1	Door Top Section	4	Top Fixture Base
2	Top Fixture Slide	5	Track Roller

3	1/4" - 20 Flange Hex Nuts / 5/16" - 18 hex Nut	6	Horizontal Track
---	--	---	------------------

For Low Headroom Applications:

See Figure 40 and Figure 41 for the following steps.

14a. Vertically align the top section ① of the door with the lower sections. Position the top fixture ② with a track roller ③ against the horizontal track ④.

14b. Maintaining the top fixture's position, install two 1/4" - 20 x 1" self drilling screws ⑤.

14c. Tighten the previously installed 1/4" - 20 x 1" self drilling screw ⑥ to secure the top fixture to the top section.

14d. Repeat for the right side.

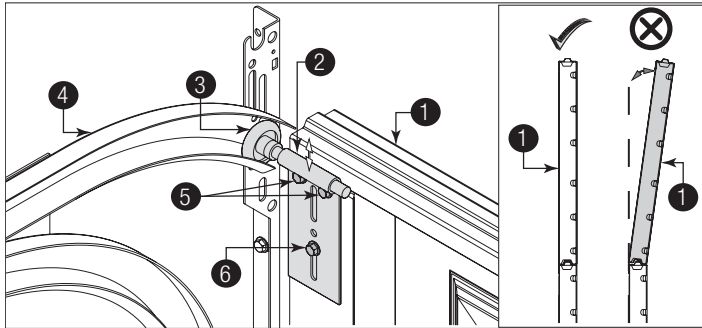

Figure 40, Left Side Shown

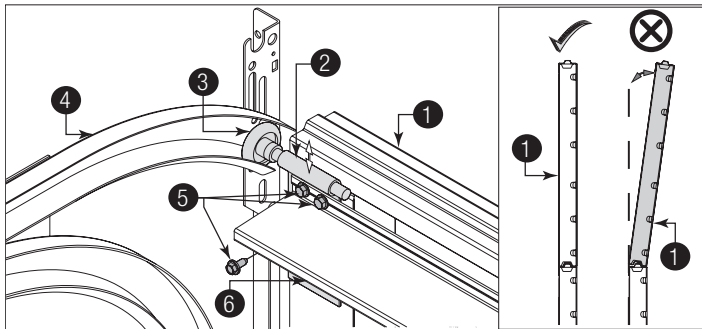

Figure 41, Left Side Shown

1	Door Top Section	4	Horizontal Track
2	Top Fixture	5	1/4" - 20 x 1" Self Drilling Screws
3	Track Roller	6	Previously Installed 1/4" - 20 x 1" Self Drilling Screw

COUNTERBALANCE INSTALLATION INSTRUCTIONS

NOTE: Refer to Breakdown of Counterbalance Parts, to determine what type of counterbalance you have.

NOTE: If your door has Standard Lift Torsion Springs, proceed to Step A1.

NOTE: If your door has Front Mount Low Headroom, Inside Hookup Torsion Springs, proceed to Step B1.

Standard Lift Torsion Springs

A1 ATTACHING END BEARING BRACKETS

NOTE: Refer to Package Contents or Breakdown Of Parts, to determine which type of end bearing bracket ① you received.

IMPORTANT: Measure the radius of your horizontal track to determine if your horizontal track ③ is 12" or 15" Radius. The end bearing bracket's lower slots ④ are used on doors with 12" radius track, the upper slots ⑤ are used on doors with 15" radius track.

IMPORTANT: Drill 3/16" pilot holes into the door jamb for the lag screws.

NOTE: End bearing brackets are right and left hand.

See Figure A42 through Figure A44 for the following steps.

A1a. Attach the left hand end bearing bracket to the left hand flag angle ② (For L3. Bracket) or through the end bearing bracket's upper / lower slots to the left hand horizontal track angle ⑥ (For L4. Bracket) using two 3/8" - 16 x 3/4" truss head bolts ⑦ and two 3/8" - 16 hex nuts ⑧.

A1b. Secure the top of the end bearing bracket to the jamb ⑨ using 5/16" x 1-5/8" lag screw(s) ⑩.

A1c. Repeat the same process for right hand side.

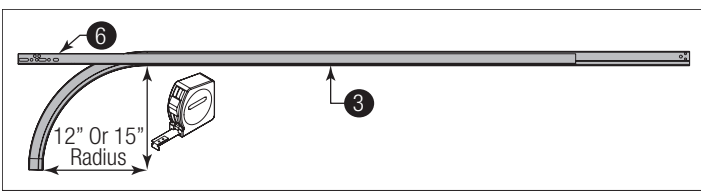

Figure A42

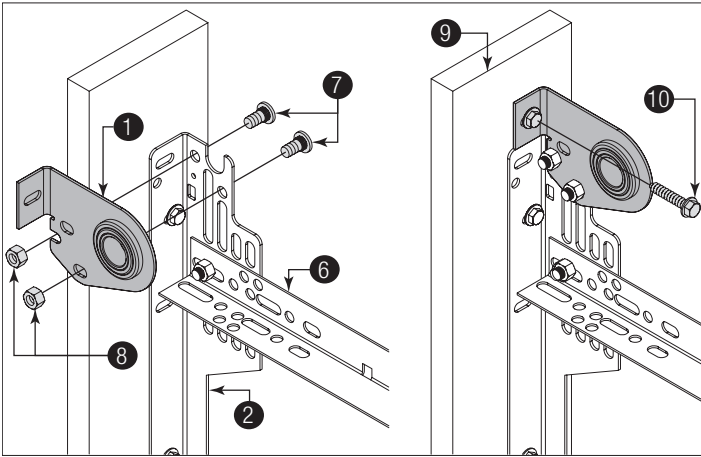

Figure A43, Left Side Shown (For L3. Bracket)

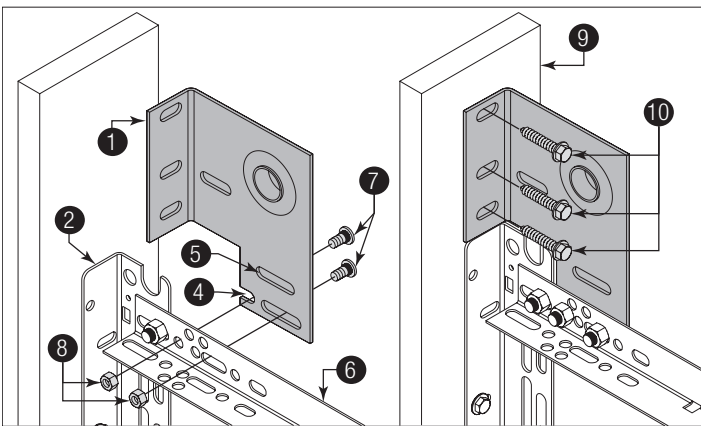

Figure A44, Left Side Shown (For L4. Bracket)

1	End Bearing Bracket	6	Horizontal Track Angle
2	Flag Angle	7	3/8" - 16 x 3/4" Truss Head Bolts
3	Horizontal Track	8	3/8" - 16 Hex Nuts
4	Lower Slots	9	Jamb
5	Upper Slots	10	5/16" x 1-5/8" Lag Screw(s)

A2 ATTACHING CENTER BRACKET TO WALL

NOTE: Refer to Package Contents / Breakdown of Parts, to determine which Center Bracket(s) came with your door.



MAKE SURE THE CENTER BRACKET IS SECURELY INSTALLED ONTO THE HEADER. FAILURE TO DO SO, COULD RESULT IN DEATH OR SERIOUS INJURY.

IMPORTANT: Drill 3/16" pilot holes into header for the lag screws.

See Figure A45 for the following steps.

A2a. First, locate the center of the door (1).

A2b. Mark a vertical pencil line (2) on the mounting surface above the door, at the center.

A2c. Measure from the center of the bearing, in one of the end bearing brackets (3), downwards, to the top of door (4).

A2d. Using that measurement, measure that distance upwards from the top of the door to the mounting surface and mark a horizontal pencil line (5) which intersects the vertical pencil line.

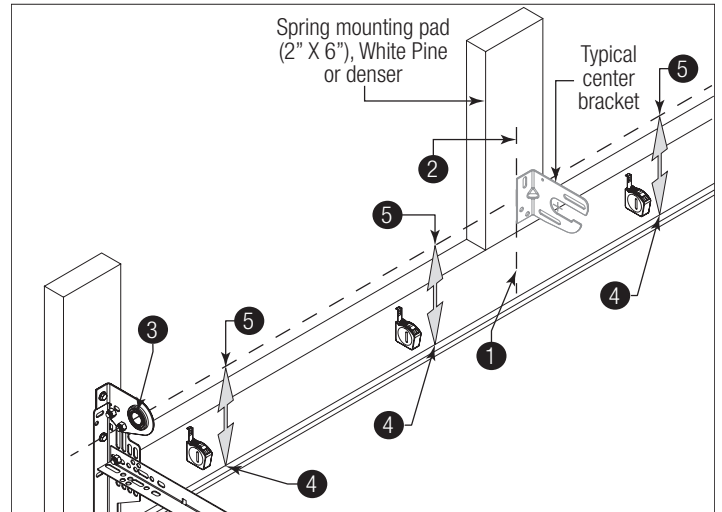

Figure A45, Left Side Shown

1	Center Of The Door	4	Top Of Door
2	Vertical Line	5	Horizontal Line
3	End Bearing Brackets		

See Figure A46 for the following steps.

A2e. Align the edge of the center bracket (6) with the vertical pencil line (2) and the center of the center bracket with the horizontal pencil line (5); this is to ensure the torsion shaft is level between the center and end bearing brackets.

NOTE: On some single spring doors, the spring can be longer than half the opening width. If your spring is longer, then the center bracket must be mounted off center for the spring to fit properly. Measure spring length adding room for spring growth during winding, to determine appropriate center bracket location.

A2f. Attach each of the center bracket(s) to the mounting surface, using 5/16" RED HEAD lag screws (7), as shown.

IMPORTANT: Use a 5/16" x 2-1/2" RED HEAD lag screw (8) instead of the 5/16" x 1-5/8" RED HEAD lag screw if mounting surface is covered by drywall. The lag screw must be attached through the bottom hole (9) of the center bracket(s). If mounting surface is a 2" x 6" board installed on top of masonry, drill a clearance hole in masonry for the 5/16" x 2-1/2" RED HEAD lag screws.

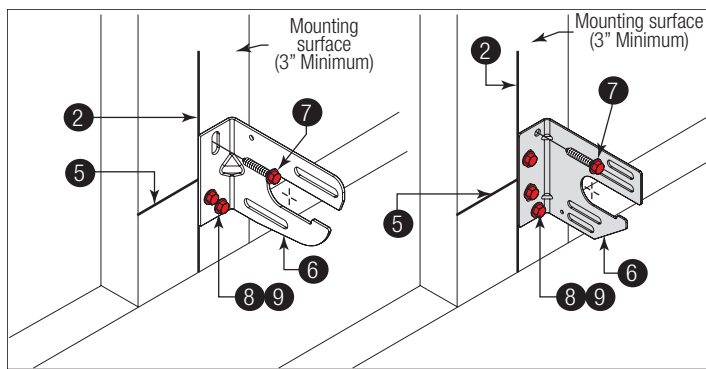

Figure A46

2	Vertical Line	7	5/16" RED HEAD Lag Screws
5	Horizontal Line	8	5/16" x 2-1/2" RED HEAD lag screw
6	Center Bracket	9	Bottom Hole

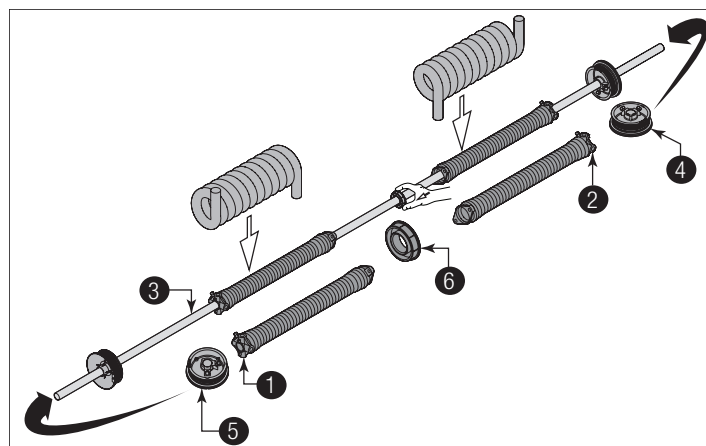

Figure A47

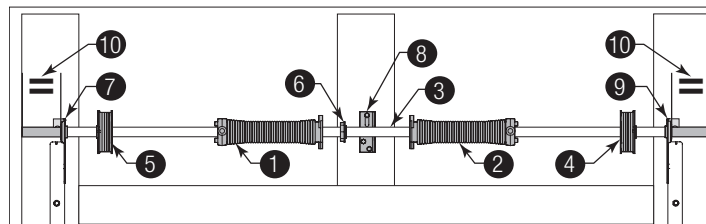

Figure A48

1	Red Winding Cone	6	Center Bracket Bearing
2	Black Winding Cone	7	End Bearing Bracket
3	Torsion Shaft	8	Center Bracket
4	Black Cable Drum	9	End Bearing Bracket
5	Red Cable Drum	10	Equal Amounts

A4 ATTACHING SPRINGS TO CENTER BRACKET

NOTE: Refer to Package Contents / Breakdown of Parts, to determine which Center Bracket(s) came with your door.

IMPORTANT: The spring warning tag(s) 1 supplied must be securely attached to the stationary spring cone(s) in plain view. Should a replacement spring warning tag be required, contact Wayne Dalton for free replacements.

NOTE: Measure the diameter of your springs. If your spring diameter is 3-3/4", the springs do not share center brackets. If your spring diameter is either 2" or 2-5/8", then two springs will share the same center bracket, unless a coupler assembly is provided.

See Figure A49 and Figure A50 for the following steps.

- A4a. Slide center bracket bearing 2 into the spring 3.
- A4b. Align the stationary spring cone(s) 4 with the holes in the center bracket 5.
- A4c. Secure the torsion spring(s) to the center bracket with (2) 3/8" - 16 x 1-1/2" hex head bolts 6 and (2) 3/8" - 16 nuts 7.

A3 TORSION SPRING ASSEMBLY

IMPORTANT: Right and left hand is always determined from inside the building looking out.

IMPORTANT: Identify the torsion springs provided as either right wound (red winding cone) 1, which goes on the LEFT HAND SIDE or left wound (black winding cone) 2, which goes on the RIGHT HAND SIDE.

IMPORTANT: On single spring applications, only a left wound (black winding cone), is required.

NOTE: The set screws used on all winding cones and cable drums are colored red. DO NOT identify right and left hand by the set screw color.

See Figure A47 and Figure A48 for the following steps.

A3a. Facing the inside of the door, lay the torsion shaft 3 on the floor. Lay the torsion spring with the black winding cone and the black cable drum 4 at the right end of the torsion shaft. Lay the torsion spring with the red winding cone and the red cable drum 5 at the left end of the torsion shaft. Slide the center bracket bearing 6 onto the torsion shaft followed by the torsion springs and cable drums.

IMPORTANT: The center bracket bearing, torsion springs, and cable drums must be positioned, as shown.

A3b. With assistance, pick up the torsion spring assembly and slide one end of the torsion shaft through one end bearing bracket 7.

A3c. Lay the middle of the torsion shaft into the center bracket 8.

A3d. Slide the other end of the torsion shaft into the other end bearing bracket 9.

A3e. Position the torsion shaft so that equal amounts 10 of the shaft extend from each end bearing bracket.

IMPORTANT: Never use more than one bearing when attaching two springs to one center bracket.

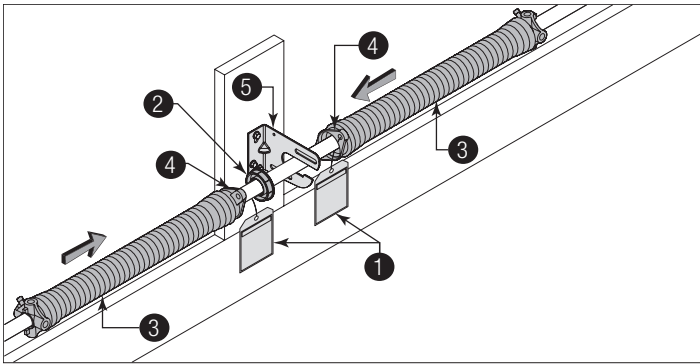

Figure A49

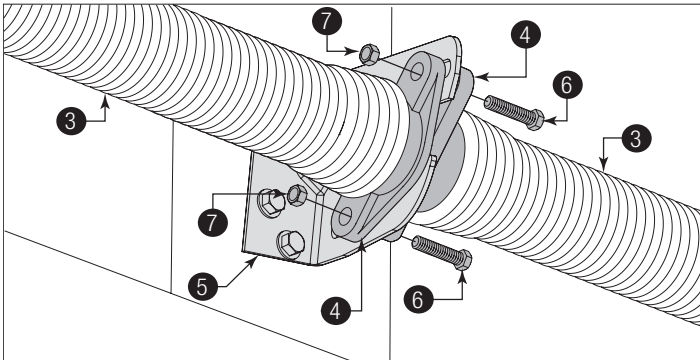

Figure A50

1	Spring Warning Tag(s)	5	Center Bracket
2	Center Bracket Bearing	6	3/8" - 16 x 1-1/2" Hex Head Bolts
3	Spring	7	3/8" - 16 Nuts
4	Stationary Spring Cone(s)		

A5 ATTACHING COUNTERBALANCE LIFT CABLES

See Figure A51 through Figure A53 for the following steps.

A5a. Starting on the left hand side, thread the counterbalance lift cable ① up and around the front side of the left hand cable drum ②.

IMPORTANT: Verify that there are no obstructions in the travel path of the door sections or counterbalance lift cables.

NOTE: Always assemble the left hand cable and cable drum first to help maintain equal cable tension on both sides of the door.

NOTICE

FAILURE TO REMOVE ALL SLACK OUT OF THE COUNTERBALANCE LIFT CABLES, WILL CAUSE DOOR OPERATIONAL PROBLEMS.

A5b. Hook ③ the counterbalance lift cable into the left hand cable drum. Slide the left hand cable drum up against the left hand end bearing bracket ④. Counterbalance lift cable should terminate at the 3 o'clock position ⑨ - 6 o'clock position ⑩.

WARNING

TO AVOID RISK OF COUNTERBALANCE FAILURE CAUSING DEATH

OR SERIOUS INJURY, THE COUNTERBALANCE LIFT CABLE MUST TERMINATE BETWEEN THE 3 O'CLOCK AND 6 O'CLOCK POSITION. IF THE COUNTERBALANCE CABLE DOES NOT TERMINATE IN THE CORRECT POSITION, THE CABLE LENGTH MUST BE CORRECTED BY A TRAINED DOOR SYSTEMS TECHNICIAN BEFORE CONTINUING INSTALLATION.

A5c. Rotate the left hand drum and torsion shaft until counterbalance lift cable is taut. Now attach locking pliers ⑥ to the torsion shaft ⑤ and brace locking pliers up against jamb ⑦ to keep counterbalance lift cable taut.

A5d. Tighten the set screws ⑧ in the drum to 14-15 ft-lbs of torque (once set screws contact the torsion shaft, tighten screws an additional 1/2 turn for solid shaft and one full turn for tubular shaft).

A5e. Repeat for right hand side.

IMPORTANT: Inspect each counterbalance lift cable making sure it is seated properly onto the cable drum and that both counterbalance lift cables have equal tension.

A5f. Check Counterbalance Lift Cables for Equal Tension:

1. Attach locking pliers to track above top roller.
2. Grasp cable at approximate mid-door height location.
3. Draw cable toward you about 1/2" to 1" and release, noting the response of the cable.
4. Repeat above steps for other cable.
5. Adjust cable tension as needed until right and left cables both respond the same.

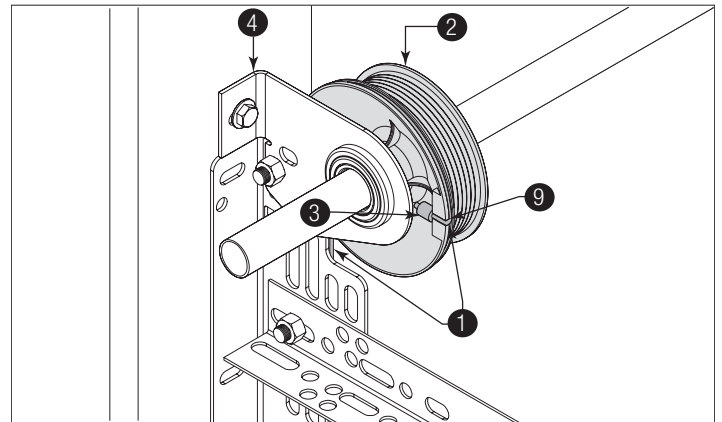

Figure A51, Left Side Shown

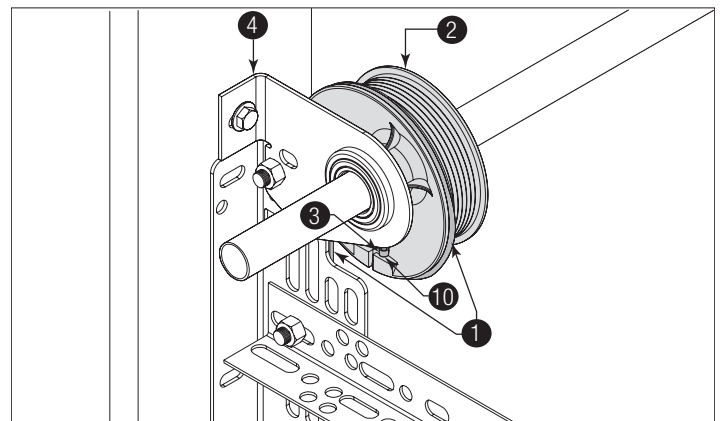

Figure A52, Left Side Shown

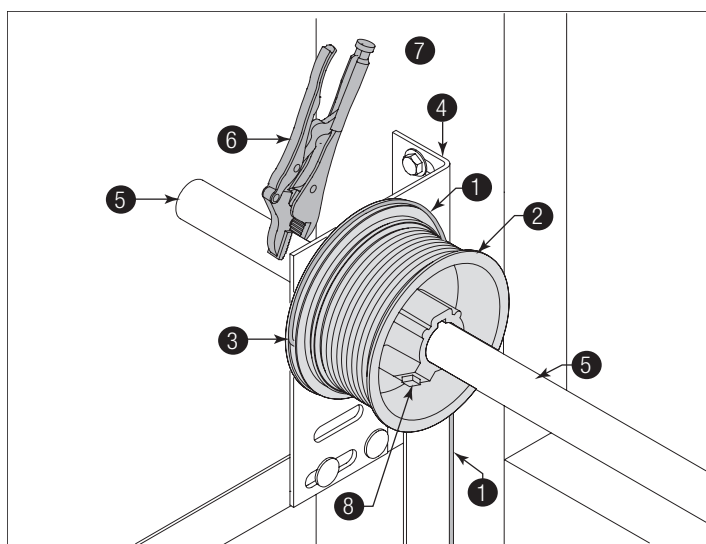

Figure A53, Left Side Shown

1	Counterbalance Lift Cable	6	Locking Pliers
2	Cable Drum	7	Jamb
3	Hook	8	Set Screws
4	End Bearing Bracket	9	3 O'Clock Position
5	Torsion Shaft	10	6 O'Clock Position

A6 CHALKING TORSION SPRING(S)

NOTE: If your springs have stenciling, then skip this step.

See Figure A54 for the following steps.

A6a. Draw a chalk line horizontally along the center of the torsion spring coils (1). As the torsion spring is wound, the chalk line will create a spiral (2). This spiral can be used to count and determine the number of turns that are applied on the torsion spring (3).

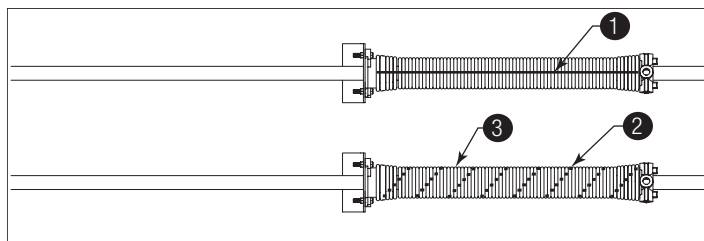

Figure A54

1	Draw horizontal chalk line prior to winding	3	Spirals created after winding
2	Spiral		

A7 SECURING DOOR FOR SPRING WINDING

See Figure A55 for the following steps.

A7a. With the door in the fully closed position, place locking pliers (4) onto both vertical tracks (1) and (2) just above the third track roller (3). This is to prevent the garage door from rising while winding spring(s). Ensure that:

A7b. **Check the following before attempting to wind torsion spring(s):**

- Counterbalance lift cables are secured at bottom corner brackets, See Figure 12 and Figure 13.
- Counterbalance lift cables are unobstructed in their route to cable drums.
- Counterbalance lift cables are correctly installed and wound onto cable lift drums.
- Counterbalance lift cables are taut and have equal tension on both sides.
- Cable lift drums are against end bearing brackets and set screws are tight.
- Torsion spring or springs are installed correctly.
- Review the label attached to the spring warning tag, to determine number of spring turns required.

! WARNING

FAILURE TO PLACE LOCKING PLIERS ONTO VERTICAL TRACKS CAN ALLOW DOOR TO RAISE DURING SPRING WINDING AND CAUSE SEVERE OR FATAL INJURY.

! CAUTION

TO AVOID POSSIBLE DAMAGE TO YOUR DOOR, THE DOOR MUST BE CLOSED AND LOCKED WHEN WINDING OR MAKING ANY ADJUSTMENTS TO THE SPRING(S).

Winding Bars (Steel Rods)	Size Of Winding Bar (Inches)	Spring Inner Diameter Used On
—	1/2" dia. x 18"	2" and 2-5/8"
—	5/8" dia. x 24"	3-3/4"

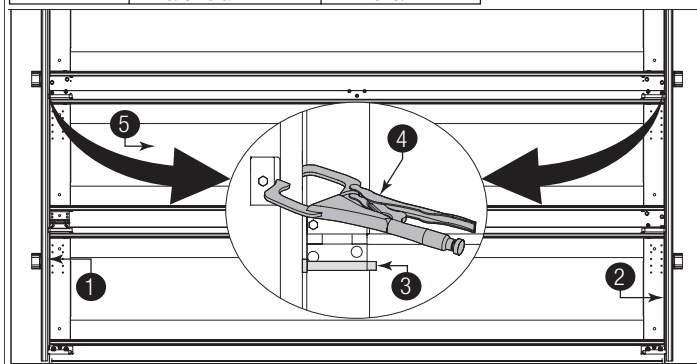

Figure A55

1	Left Side Vertical Track	5	Bottom Section
2	Right Side Vertical Track	6	Second Section
3	Track Roller	7	Intermediate Section
4	Locking Pliers		

A8 WINDING SPRING(S)

! DANGER

WINDING SPRING IS AN EXTREMELY DANGEROUS PROCEDURE AND SHOULD BE PERFORMED ONLY BY A TRAINED DOOR SYSTEM TECHNICIAN USING PROPER TOOLS AND INSTRUCTIONS.

! WARNING

USE ONLY SPECIFIED WINDING BARS, AS STATED IN STEP SECURING DOOR FOR SPRING WINDING. DO NOT SUBSTITUTE WITH SCREWDRIVERS, PIPE, ETC. OTHER TOOLS MAY FAIL OR RELEASE FROM THE SPRING CONE AND

CAUSE SEVERE OR FATAL INJURY.



PRIOR TO WINDING THE SPRING, ENSURE YOU'RE WINDING IN THE PROPER DIRECTION AS SHOWN IN FIGURE A56. OTHERWISE THE SPRING FITTING MAY RELEASE FROM SPRING AND RESULT IN SEVERE OR FATAL INJURY.

A8a. Position a ladder slightly to the side of the spring so that the winding cone is easily accessible, and so your body is not directly in line with the winding bars ①.

A8b. Check the label attached to the spring warning tag ② for the required number of complete turns to balance your door.

How to Wind Torsion Springs:

1. Insert one winding rod snugly into winding cone ③, to full socket depth.
2. Maintaining a tight grip on the winding rod rotate it slowly in the proper direction ④, as shown below.
3. If there is any slippage of the winding rod in the winding cone socket, reverse the direction of winding and return the cone to its original position. Remove the winding rod from the winding cone socket. Reseat the winding rod in the socket. Start over at Step #1.
4. When the winding rod is vertical above the winding cone, insert another winding rod into one of the other sockets, being careful to seat it snugly and at full socket depth.
5. Hold the spring with the second winding bar, and remove the first.
6. Repeat Steps #2 through #5 until the complete turns have been applied.

IMPORTANT: Check the warning tag(s) attached to the spring(s) for the required number of complete turns, to balance your door.

IMPORTANT: After winding the spring(s), tighten the set screws ⑤ in the winding cone to 14-15 ft-lbs of torque (once set screws contact the torsion shaft ⑥, tighten screws an additional 1/2 turn for solid shaft and one full turn for tubular shaft).

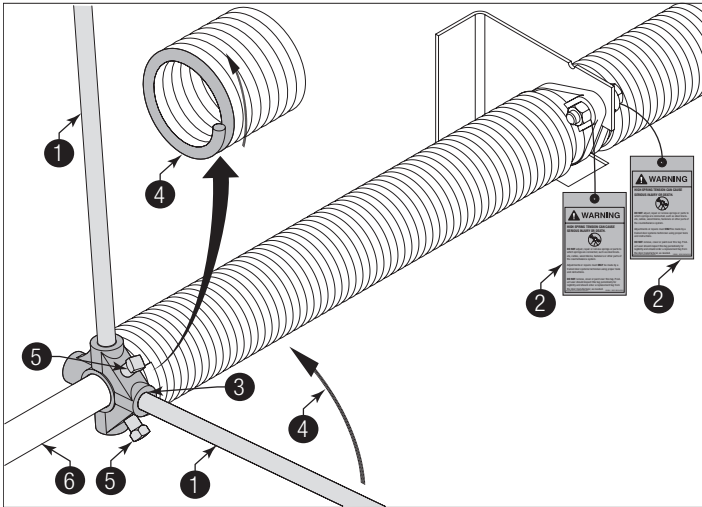

Figure A56

1	Approved Winding Rods	4	Proper Direction
2	Spring Warning Tag	5	Set Screws
3	Winding Cone	6	Torsion Shaft

IN THE EVENT THE SPRING(S) WERE OVER-WOUND, HOLD THE DOOR DOWN FIRMLY AND CAUTIOUSLY REMOVE LOCKING PLIERS FROM VERTICAL TRACKS TO PREVENT IT FROM RISING UNEXPECTEDLY.

See Figures A57, A58, and A59 for the following steps.

A9a. Raise the door until the top section and half of the next section are in the horizontal track radius. Do not raise door any further since rear of horizontal tracks are not yet supported.



RAISING THE DOOR FURTHER INTO THE LOOSE HORIZONTAL TRACKS CAN RESULT IN DOOR FALLING CAUSING DEATH OR SERIOUS INJURY.

IMPORTANT: If an opener is installed, position horizontal tracks one hole above level when securing them to the rear back hangs.

A9b. Using the chart below, select the appropriate perforated angle. Fabricate and install rear back hangs, as shown.

Perforated Angle Gauge Weight Limitations:	
Perforated Angle Gauge	Door Balance Weight
2" x 2" x 12 Gauge	800 lbs. to 1600 lbs.
1-1/4" x 1-1/4" x 13 Gauge	305 lb. to 610 lb.
1-1/4" x 1-1/4" x 15 Gauge	220 lb. to 440 lb.
1-1/4" x 1-1/4" x 16 Gauge	175 lb. to 350 lb.



KEEP HORIZONTAL TRACKS PARALLEL AND WITHIN 3/4" TO 7/8" (19 MM - 22 MM) MAXIMUM OF DOOR EDGE. OTHERWISE THE TRACK ROLLERS CAN COME OUT AND DOOR WILL FALL, RESULTING IN DEATH OR SERIOUS INJURY.



MAKE SURE BACK HANGS ARE BRACED SUFFICIENTLY TO RESIST ANY MOTION DURING SPRING APPLICATION AND DOOR TRAVEL. IF BACK HANGS PIVOT OR DEFLECT, ADD REINFORCEMENT UNTIL THEY REMAIN FIRM AND STATIONARY. ANY BACK HANG THAT HAS BEEN BENT MUST BE REPLACED. FAILURE TO SECURELY BRACE THE HORIZONTAL TRACK CAN RESULT IN DOOR FALLING CAUSING DEATH OR SERIOUS INJURY.



DO NOT SUPPORT THE WEIGHT OF THE DOOR ON ANY PART OF THE REAR BACK HANGS THAT IS 4" (102 MM) OR MORE BEYOND A SOUND FRAMING MEMBER.



IF REAR BACK HANGS ARE TO BE INSTALLED OVER DRYWALL, USE TWO 5/16" X 2" HEX-HEAD LAG SCREWS AND MAKE SURE LAG SCREWS ENGAGE INTO SOLID STRUCTURAL LUMBER.



FAILURE TO ASSEMBLE AND ATTACH REAR BACK HANGS PROPERLY ACCORDING TO THE ABOVE INSTRUCTIONS MAY RESULT IN DOOR FALLING WHEN RAISED, CAUSING DEATH OR SERIOUS INJURY.

A9 ATTACHING REAR BACK HANGS (NOT INCLUDED)



NOTICE

PERFORATED ANGLE MUST BE ATTACHED TO SOUND FRAMING MEMBERS AND NAILS SHOULD NOT BE USED.

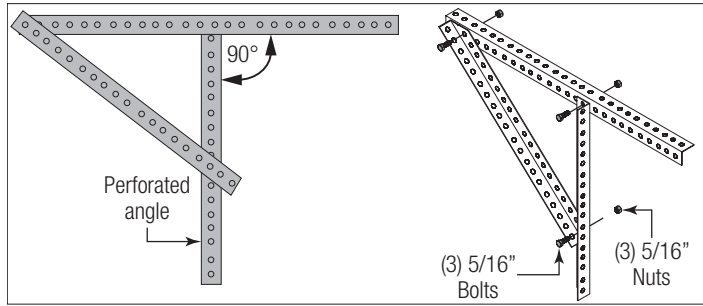

Figure A57

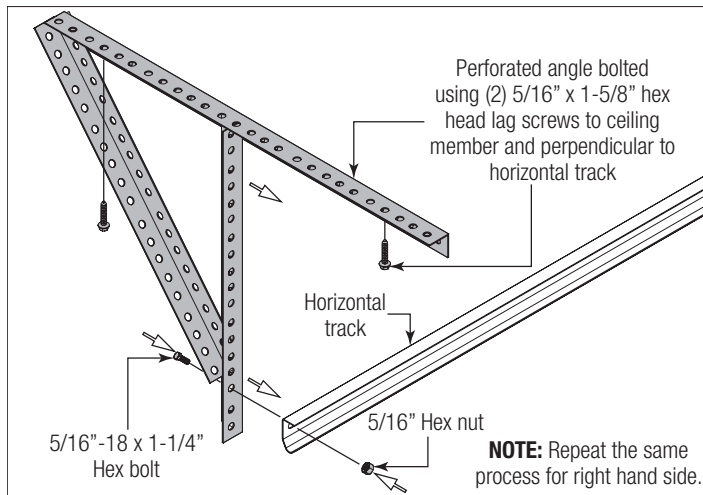

Figure A58

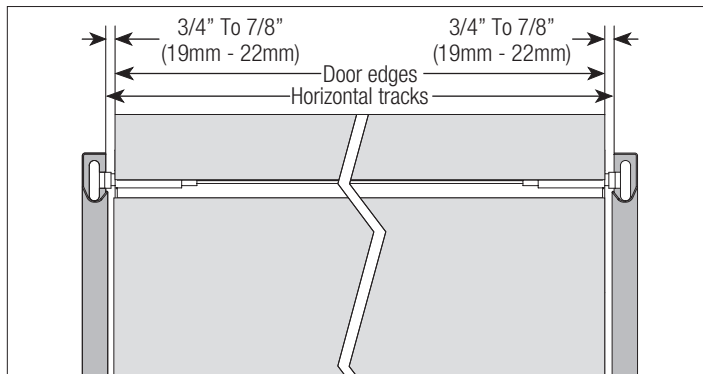

Figure A59

A10 ATTACHING WEATHERSTRIPS (NOT INCLUDED)

NOTICE

WHEN PERMANENTLY ATTACHING THE WEATHERSTRIPS TO THE JAMBS, AVOID PUSHING THE WEATHER-STRIPS TOO TIGHTLY AGAINST THE FACE OF DOOR.

See Figure A60 for the following steps.

A10a. Permanently attach the nails to the weatherstrips on both door jambs ① and the header ②. The weatherstrips were temporarily attached in Preparing the Opening, in the pre-installation section of this manual.

NOTE: For clarity, door isn't shown.

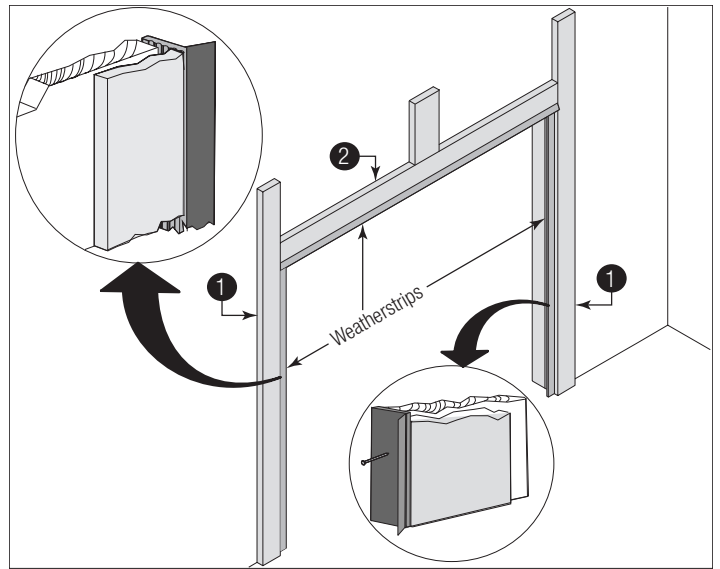

Figure A60, Weatherstrips

1	Door Jambs	2	Header
---	------------	---	--------

A11 BALANCING DOOR

CAUTION

WINDOWS MAY CAUSE THE TOP SECTION TO BE SIGNIFICANTLY HEAVIER THAN THE REMAINING SECTIONS. TO PREVENT ANY SUDDEN DOOR ACCELERATION BETWEEN THE TOP AND BOTTOM, MOTOR OPERATE ALL DOORS WITH WINDOWS.

DANGER

EXTREME CAUTION SHOULD BE USED WHEN MAKING ADJUSTMENTS TO THE SPRINGS AS FAILURE TO FOLLOW THE INSTRUCTIONS OR USE APPROVED WINDING BARS CAN LEAD TO DEATH OR SERIOUS INJURY TO PERSONS OR PROPERTY. BEFORE ATTEMPTING TO MAKE ADJUSTMENTS TO THE SPRING, MAKE SURE YOU HAVE READ AND UNDERSTAND THE INSTRUCTIONS. IF YOU ARE UNCLEAR ON ANY ASPECT OF THE INSTALLATION PROCEDURES, YOU SHOULD CONSULT A TRAINED DOOR SYSTEMS TECHNICIAN.

See Figure A61 for the following steps.

A11a. Remove locking pliers. Lift door and check its balance. Adjustments to the required number of spring turns stated may be necessary. If door rises off floor more than 2 ft. under spring tension alone, reduce spring tension. If the door is hard to rise or drifts down on its own, add spring tension. A poorly balanced door can cause garage door operator problems.

A11b. To adjust spring tension, fully close door. Apply locking pliers to track above third track roller. Place locking pliers on torsion shaft, as shown in Step Attaching Counterbalance Lift Cables. Insert a winding rod ① into the winding cone. Push upward on the winding rod slightly while carefully loosening the set screws ② in the winding cone ③.

WARNING

BE PREPARED TO SUPPORT THE FULL FORCE OF THE TORSION SPRING ONCE THE SET SCREWS ARE LOOSE. IF NOT PREPARED, THEN THE WINDING BAR CAN MOVE SUDDENLY AND COME OUT OF THE WINDING CONE AND CAUSE SEVERE OR FATAL INJURY.

Carefully adjust spring tension 1/4 turn. Retighten both set screws to 14-15 ft. lbs. of torque in the winding cone and repeat for the other side. Recheck door balance and re-adjust spring tension if needed.

IMPORTANT: Do not adjust more than 1 turn from the recommended number of turns.

If the door still does not operate easily, lower the door into the closed position, unwind spring(s) completely, and recheck the following items:

A11c. Is the door level?

A11d. Are the torsion shaft and flag angles level and plumb?

A11e. Does the distance between the flag angles equal door width plus 3-3/8" to 3-1/2"?

A11f. Do the counterbalance lift cables have equal tension? Adjust if necessary.

A11g. Rewind the spring(s).

A11h. Make sure door is not rubbing on jambs.

IMPORTANT: If door still does not balance properly, then contact a trained door system technician.

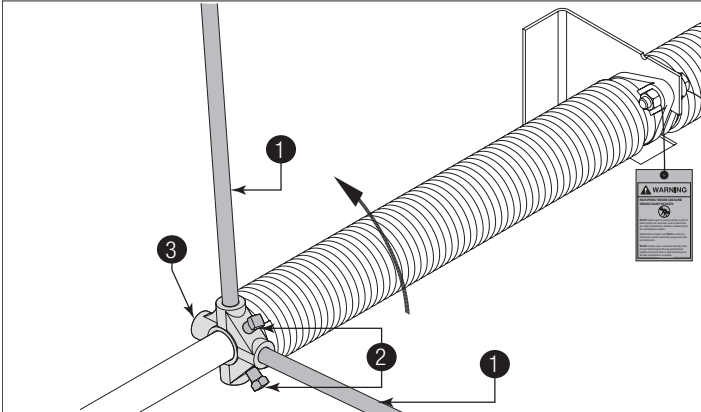

Figure A61

1	Winding Rod	3	Winding Cone
2	Set Screws		

Front Mount LHR Inside Hookup Torsion Springs

B1 ATTACHING END BEARING BRACKETS

IMPORTANT: Spacing specified below MUST be maintained between the end bearing bracket (1) and the flag angle (2). This is to ensure proper clearance of the counterbalance lift cable.

NOTE: Ensure the 3/8" - 16 x 3/4" truss head bolt is going through the inside portion of flag angle first and the 3/8" - 16 hex nut is on the outside of the flag angle.

IMPORTANT: Drill 3/16" pilot holes into the door jamb for the lag screws.

NOTE: End bearing brackets are right and left hand.

See Figure B42 and Figure B43 for the following steps.

B1a Using a tape measure, determine if the bottom curve of the horizontal track (3) is either 12" Radius or 15" Radius. If your bottom curve is 12" Radius (4), the spacing will need to be 1" (5). If your bottom curve is 15" Radius (6), the spacing will need to be 1/2" (7).

B1b. Loosely attach the end bearing bracket to the flag angle using one 3/8" - 16 x 3/4" truss head bolt (8) and one 3/8" - 16 nut (9).

B1c. Once the end bearing bracket is properly positioned, tighten the 3/8" - 16 nut to secure the end bearing bracket to the flag angle.

B1d. Secure the end bearing bracket to the jamb using two 5/16" x 1-5/8" lag screws (10).

B1e. Repeat same process for the other side.

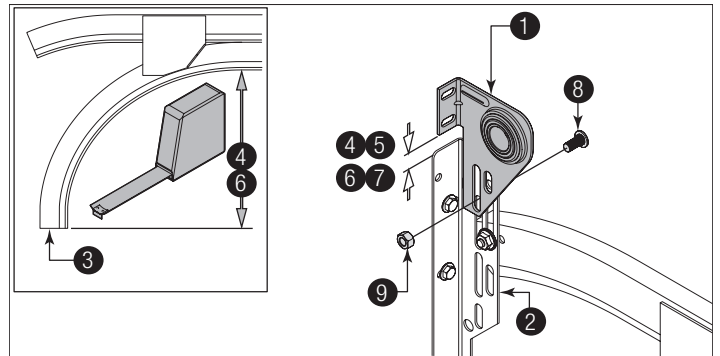

Figure B42, Left Side Shown

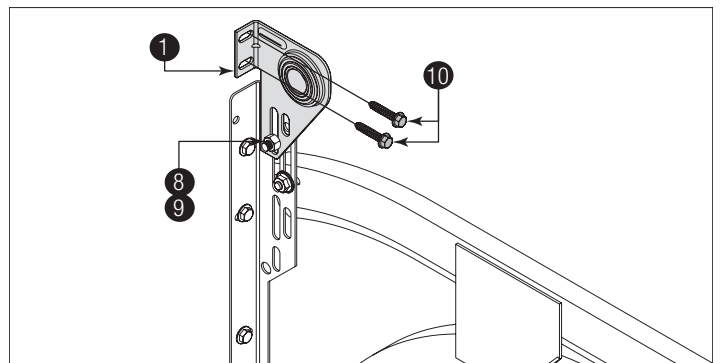

Figure B43, Left Side Shown

1	End Bearing Bracket	6	15" Radius
2	Flag Angle	7	1/2"

3	Bottom Curve Of The Horizontal Track	8	3/8" - 16 x 3/4" Truss Head Bolts
4	12" Radius	9	3/8" - 16 Hex Nuts
5	1"	10	5/16" x 1-5/8" Lag Screw(s)

B2 ATTACHING CENTER BRACKET TO WALL

WARNING

MAKE SURE THE CENTER BRACKET IS SECURELY INSTALLED ONTO THE HEADER. FAILURE TO DO SO, COULD RESULT IN DEATH OR SERIOUS INJURY.

IMPORTANT: Drill 3/16" pilot holes into header for the lag screws.

NOTE: On some single spring doors, the spring can be longer than half the opening width. If your spring is longer, then the center bracket must be mounted off center for the spring to fit properly. Measure spring length adding room for spring growth during winding, to determine appropriate center bracket location.

See Figure B44 for the following steps.

B2a. First, locate the center of the door ①.

B2b. Mark a vertical pencil line ② on the mounting surface above the door, at the center.

B2c. Measure from the center of the bearing, in one of the end bearing brackets ③, downwards, to the top of door ④.

B2d. Using that measurement, measure that distance upwards from the top of the door to the mounting surface and mark a horizontal pencil line ⑤ which intersects the vertical pencil line.

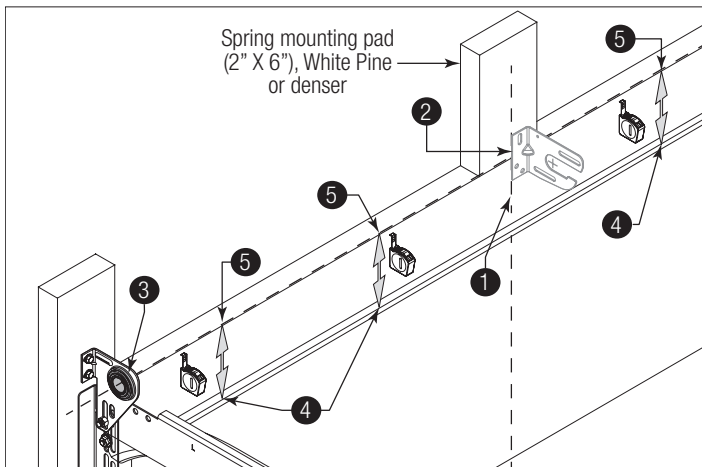

Figure B44, Left Side Shown

1	Center Of The Door	4	Top Of Door
2	Vertical Line	5	Horizontal Line
3	End Bearing Brackets		

See Figure B45 for the following steps.

B2e. Mark a vertical pencil line ① on the mounting surface above the door, at the center.

B2f. Align the edge of the center bracket ② with the vertical pencil line and the center of the center bracket with the horizontal pencil line ③; this is to ensure the torsion shaft is level between the center and end bearing brackets.

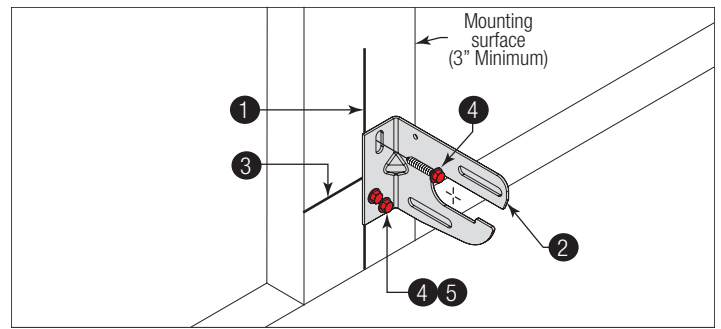

Figure B45

1	Vertical Line	3	Horizontal Line
2	Center Bracket		

B3 TORSION SPRING ASSEMBLY

IMPORTANT: Right and left hand is always determined from inside the building looking out.

IMPORTANT: Identify the torsion springs provided as either right wound (red winding cone) ①, which goes on the LEFT HAND SIDE or left wound (black winding cone) ②, which goes on the RIGHT HAND SIDE.

IMPORTANT: On single spring applications, only a left wound (black winding cone), is required.

NOTE: The set screws used on all winding cones and cable drums are colored red. DO NOT identify right and left hand by the set screw color.

See Figure B46 and Figure B47 for the following steps.

B3a. Facing the inside of the door, lay the torsion shaft ③ on the floor. Lay the torsion spring with the black winding cone and the black cable drum ④ at the right end of the torsion shaft. Lay the torsion spring with the red winding cone and the red cable drum ⑤ at the left end of the torsion shaft. Slide the center bracket bearing ⑥ onto the torsion shaft followed by the torsion springs and cable drums.

IMPORTANT: The center bracket bearing, torsion springs, and cable drums must be positioned, as shown.

B3b. With assistance, pick up the torsion spring assembly and slide one end of the torsion shaft through one end bearing bracket ⑦.

B3c. Lay the middle of the torsion shaft into the center bracket ⑧.

B3d. Slide the other end of the torsion shaft into the other end bearing bracket ⑨.

B3e. Position the torsion shaft so that equal amounts ⑩ of the shaft extend from each end bearing bracket.

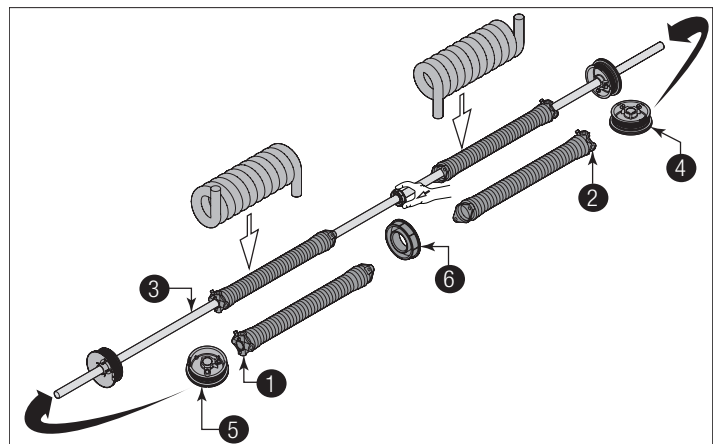

Figure B46

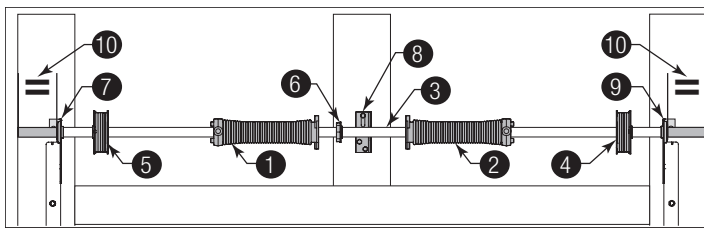

Figure B47

1	Red Winding Cone	6	Center Bracket Bearing
2	Black Winding Cone	7	End Bearing Bracket
3	Torsion Shaft	8	Center Bracket
4	Black Cable Drum	9	End Bearing Bracket
5	Red Cable Drum	10	Equal Amounts

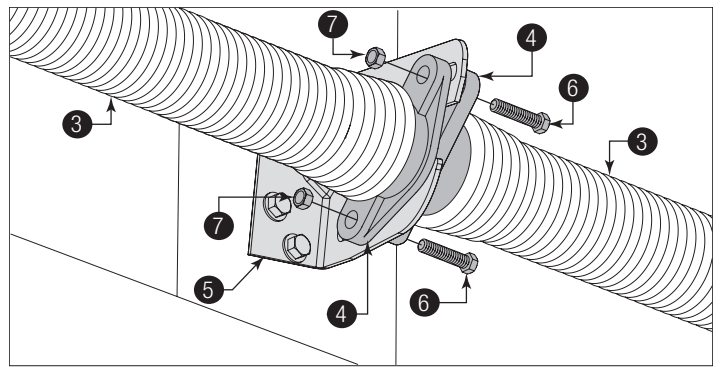

Figure B49

1	Spring Warning Tag(s)	5	Center Bracket
2	Center Bracket Bearing	6	3/8" - 16 x 1-1/2" Hex Head Bolts
3	Spring	7	3/8" - 16 Nuts
4	Stationary Spring Cone(s)		

B4 ATTACHING SPRINGS TO CENTER BRACKET

NOTE: Refer to Package Contents / Breakdown of Parts, to determine which Center Bracket(s) came with your door.

NOTE: Refer to Package Contents / Breakdown of Parts, to determine if your door came with a coupler assembly.

IMPORTANT: The spring warning tag(s) ① supplied must be securely attached to the stationary spring cone(s) in plain view. Should a replacement spring warning tag be required, contact Wayne Dalton for free replacements.

See Figure B48 and Figure B49 for the following steps.

B4a. Slide center bracket bearing ② into the spring ③.

B4b. Align the stationary spring cone(s) ④ with the holes in the center bracket ⑤.

B4c. Secure the torsion spring(s) to the center bracket with (2) 3/8" - 16 x 1-1/2" hex head bolts ⑥ and (2) 3/8" - 16 nuts ⑦.

IMPORTANT: Never use more than one bearing when attaching two springs to one center bracket.

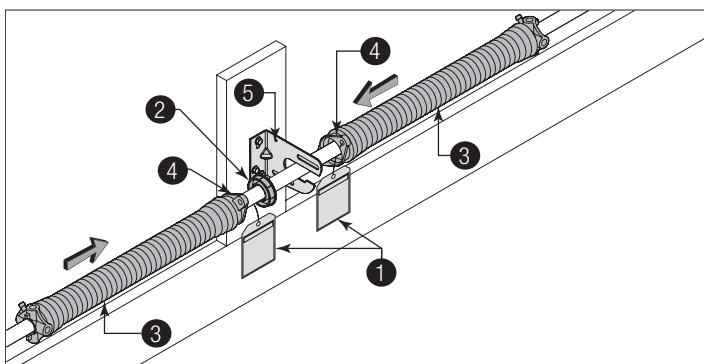

Figure B48

B5 ATTACHING COUNTERBALANCE LIFT CABLES

See Figure B50 through Figure B52 for the following steps.

B5a. Starting on the left hand side, thread the counterbalance lift cable ① up and around the front side of the left hand cable drum ②.

IMPORTANT: Verify that there are no obstructions in the travel path of the door sections or counterbalance lift cables.

NOTE: Always assemble the left hand cable and cable drum first to help maintain equal cable tension on both sides of the door.

NOTICE

FAILURE TO REMOVE ALL SLACK OUT OF THE COUNTERBALANCE LIFT CABLES, WILL CAUSE DOOR OPERATIONAL PROBLEMS.

B5b. Hook ③ the counterbalance lift cable into the left hand cable drum. Slide the left hand cable drum up against the left hand end bearing bracket ④. Counterbalance lift cable should terminate at the 3 o'clock position ⑨ - 6 o'clock position ⑩.

WARNING

TO AVOID RISK OF COUNTERBALANCE FAILURE CAUSING DEATH OR SERIOUS INJURY, THE COUNTERBALANCE LIFT CABLE MUST TERMINATE BETWEEN THE 3 O'CLOCK AND 6 O'CLOCK POSITION. IF THE COUNTERBALANCE CABLE DOES NOT TERMINATE IN THE CORRECT POSITION, THE CABLE LENGTH MUST BE CORRECTED BY A TRAINED DOOR SYSTEMS TECHNICIAN BEFORE CONTINUING INSTALLATION.

B5c. Rotate the left hand drum and torsion shaft until counterbalance lift cable is taut. Now attach locking pliers ⑤ to the torsion shaft ⑥ and brace locking pliers up against jamb ⑦ to keep counterbalance lift cable taut.

B5d. Tighten the set screws ⑧ in the drum to 14-15 ft-lbs of torque (once set screws contact the torsion shaft, tighten screws an additional 1/2 turn for solid shaft and one full turn for tubular shaft).

B5e. Repeat for right hand side.

IMPORTANT: Inspect each counterbalance lift cable making sure it is seated properly onto the cable drum and that both counterbalance lift cables have equal tension.

B5f. Check Counterbalance Lift Cables for Equal Tension:

1. Attach locking pliers to track above top roller.
2. Grasp cable at approximate mid-door height location.
3. Draw cable toward you about 1/2" to 1" and release, noting the response of the cable.
4. Repeat above steps for other cable.
5. Adjust cable tension as needed until right and left cables both respond the same.

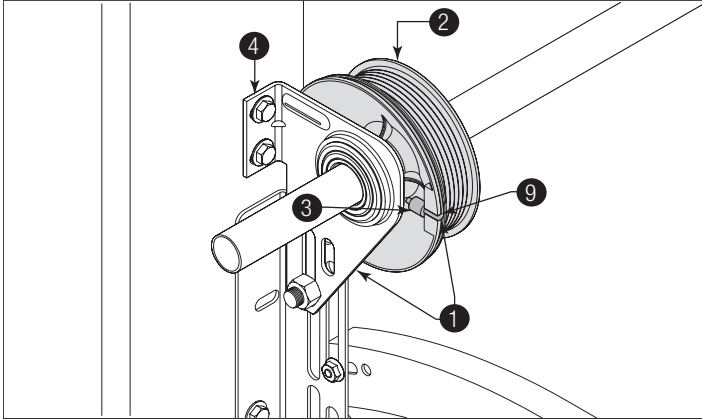

Figure B50, Left Side Shown

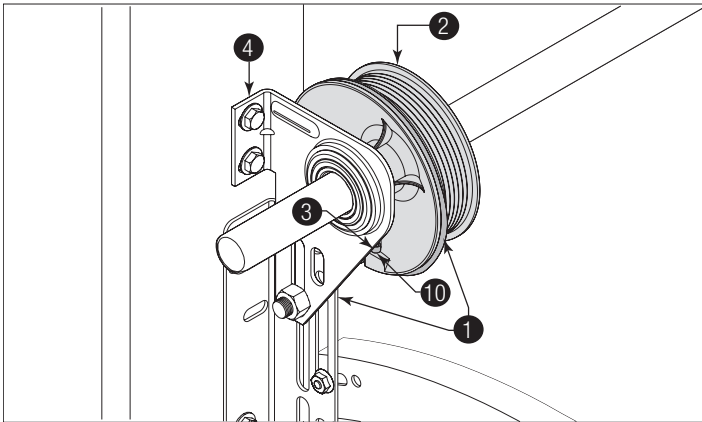

Figure B51, Left Side Shown

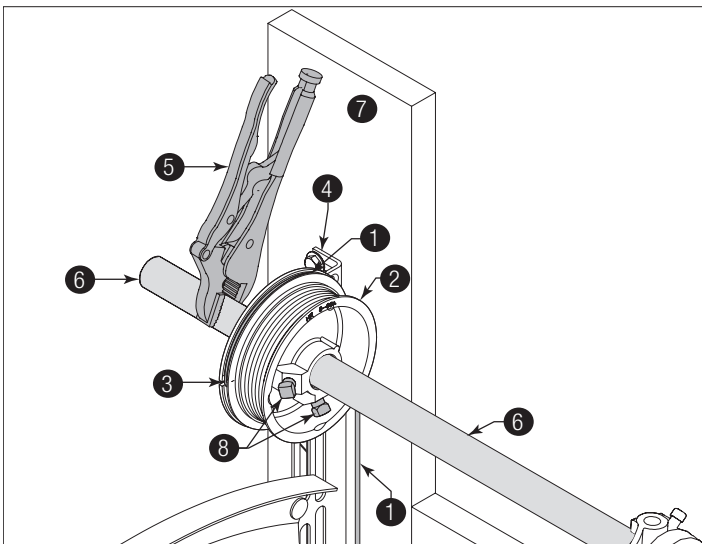

Figure B52, Left Side Shown

1	Counterbalance Lift Cable	6	Torsion Shaft
2	Cable Drum	7	Jamb
3	Hook	8	Set Screws
4	End Bearing Bracket	9	3 O'Clock Position
5	Locking Pliers	10	6 O'Clock Position

B6 CHALKING TORSION SPRING(S)

NOTE: If your springs have stenciling, then skip this step.

See Figure B53 for the following steps.

B6a. Draw a chalk line horizontally along the center of the torsion spring coils (1). As the torsion spring is wound, the chalk line will create a spiral (2). This spiral can be used to count and determine the number of turns that are applied on the torsion spring (3).

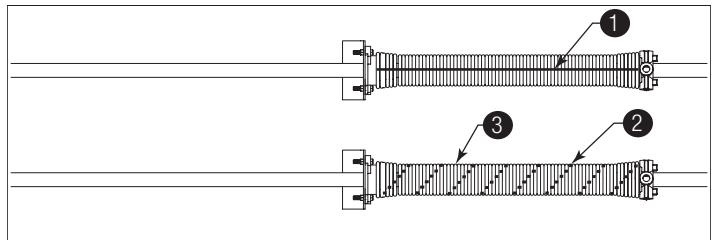

Figure B53

1	Draw horizontal chalk line prior to winding	3	Spirals created after winding
2	Spiral		

B7 SECURING DOOR FOR SPRING WINDING

See Figure B54 for the following steps.

B7a. With the door in the fully closed position, place locking pliers (4) onto both vertical tracks (1) and (2) just above the third track roller (3). This is to prevent the garage door from rising while winding spring(s). Ensure that:

B7b. **Check the following before attempting to wind torsion spring(s):**

- Counterbalance lift cables are secured at bottom corner brackets, See Figure 12 and Figure 13.
- Counterbalance lift cables are unobstructed in their route to cable drums.
- Counterbalance lift cables are correctly installed and wound onto cable lift drums.
- Counterbalance lift cables are taut and have equal tension on both sides.
- Cable lift drums are against end bearing brackets and set screws are tight.
- Torsion spring or springs are installed correctly.
- Review the label attached to the spring warning tag, to determine number of spring turns required.

WARNING

FAILURE TO PLACE LOCKING PLIERS ONTO VERTICAL TRACKS CAN ALLOW DOOR TO RAISE DURING SPRING WINDING AND CAUSE SEVERE OR FATAL INJURY.

CAUTION

TO AVOID POSSIBLE DAMAGE TO YOUR DOOR, THE DOOR MUST BE CLOSED AND LOCKED WHEN WINDING OR MAKING ANY ADJUSTMENTS TO THE SPRING(S).

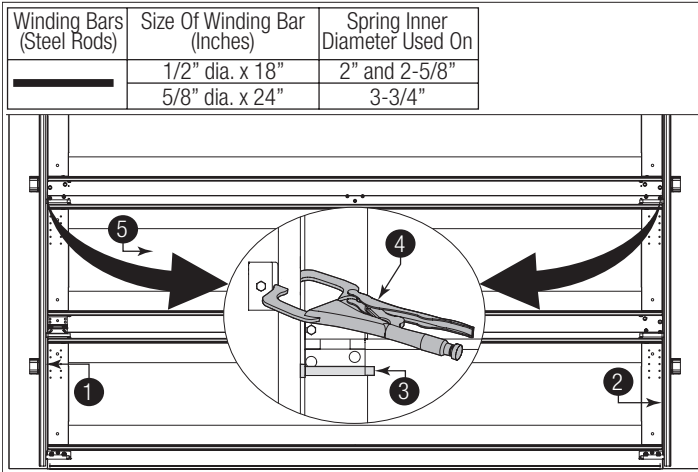

Figure B54

1	Left Side Vertical Track	5	Bottom Section
2	Right Side Vertical Track	6	Second Section
3	Track Roller	7	Intermediate Section
4	Locking Pliers		

B8 WINDING SPRING(S)

DANGER

WINDING SPRING IS AN EXTREMELY DANGEROUS PROCEDURE AND SHOULD BE PERFORMED ONLY BY A TRAINED DOOR SYSTEM TECHNICIAN USING PROPER TOOLS AND INSTRUCTIONS.

WARNING

USE ONLY SPECIFIED WINDING BARS, AS STATED IN STEP SECURING DOOR FOR SPRING WINDING. DO NOT SUBSTITUTE WITH SCREWDRIVERS, PIPE, ETC. OTHER TOOLS MAY FAIL OR RELEASE FROM THE SPRING CONE AND CAUSE SEVERE OR FATAL INJURY.

DANGER

PRIOR TO WINDING THE SPRING, ENSURE YOU'RE WINDING IN THE PROPER DIRECTION AS SHOWN IN FIGURE B55. OTHERWISE THE SPRING FITTING MAY RELEASE FROM SPRING AND RESULT IN SEVERE OR FATAL INJURY.

B8a. Position a ladder slightly to the side of the spring so that the winding cone is easily accessible, and so your body is not directly in line with the winding bars ①.

B8b. Check the label attached to the spring warning tag ② for the required number of complete turns to balance your door.

How to Wind Torsion Springs:

1. Insert one winding rod snugly into winding cone ③, to full socket depth.
2. Maintaining a tight grip on the winding rod rotate it slowly in the proper direction ④, as shown below.

3. If there is any slippage of the winding rod in the winding cone socket, reverse the direction of winding and return the cone to its original position. Remove the winding rod from the winding cone socket. Reseat the winding rod in the socket. Start over at Step #1.

4. When the winding rod is vertical above the winding cone, insert another winding rod into one of the other sockets, being careful to seat it snugly and at full socket depth.

5. Hold the spring with the second winding bar, and remove the first.

6. Repeat Steps #2 through #5 until the complete turns have been applied.

IMPORTANT: Check the warning tag(s) attached to the spring(s) for the required number of complete turns, to balance your door.

IMPORTANT: After winding the spring(s), tighten the set screws ⑤ in the winding cone to 14-15 ft-lbs of torque (once set screws contact the torsion shaft ⑥, tighten screws an additional 1/2 turn for solid shaft and one full turn for tubular shaft).

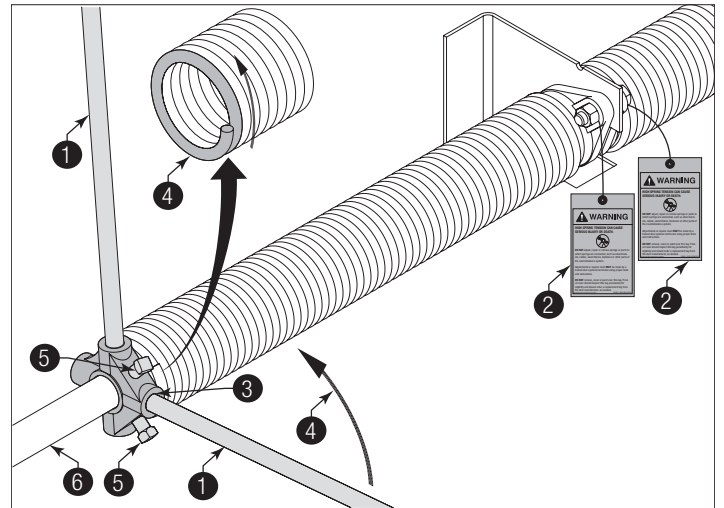

Figure B55

1	Approved Winding Rods	4	Proper Direction
2	Spring Warning Tag	5	Set Screws
3	Winding Cone	6	Torsion Shaft

B9 ATTACHING REAR BACK HANGS (NOT INCLUDED)

WARNING

IN THE EVENT THE SPRING(S) WERE OVER-WOUND, HOLD THE DOOR DOWN FIRMLY AND CAUTIOUSLY REMOVE LOCKING PLIERS FROM VERTICAL TRACKS TO PREVENT IT FROM RISING UNEXPECTEDLY.

See Figures B56, B57, and B58 for the following steps.

B9a. Raise the door until the top section and half of the next section are in the horizontal track radius. Do not raise door any further since rear of horizontal tracks are not yet supported.

WARNING

RAISING THE DOOR FURTHER INTO THE LOOSE HORIZONTAL TRACKS CAN RESULT IN DOOR FALLING CAUSING DEATH OR SERIOUS INJURY.

IMPORTANT: If an opener is installed, position horizontal tracks one hole above level when securing them to the rear back hangs.

B9b. Using the chart below, select the appropriate perforated angle. Fabricate and install rear back hangs, as shown.

Perforated Angle Gauge Weight Limitations:	
Perforated Angle Gauge	Door Balance Weight
2" x 2" x 12 Gauge	800 lbs. to 1600 lbs.
1-1/4" x 1-1/4" x 13 Gauge	305 lb. to 610 lb.
1-1/4" x 1-1/4" x 15 Gauge	220 lb. to 440 lb.
1-1/4" x 1-1/4" x 16 Gauge	175 lb. to 350 lb.

WARNING

KEEP HORIZONTAL TRACKS PARALLEL AND WITHIN 3/4" TO 7/8" (19 MM - 22 MM) MAXIMUM OF DOOR EDGE. OTHERWISE THE TRACK ROLLERS CAN COME OUT AND DOOR WILL FALL, RESULTING IN DEATH OR SERIOUS INJURY.

WARNING

MAKE SURE BACK HANGS ARE BRACED SUFFICIENTLY TO RESIST ANY MOTION DURING SPRING APPLICATION AND DOOR TRAVEL. IF BACK HANGS PIVOT OR DEFLECT, ADD REINFORCEMENT UNTIL THEY REMAIN FIRM AND STATIONARY. ANY BACK HANG THAT HAS BEEN BENT MUST BE REPLACED. FAILURE TO SECURELY BRACE THE HORIZONTAL TRACK CAN RESULT IN DOOR FALLING CAUSING DEATH OR SERIOUS INJURY.

NOTICE

DO NOT SUPPORT THE WEIGHT OF THE DOOR ON ANY PART OF THE REAR BACK HANGS THAT IS 4" (102 MM) OR MORE BEYOND A SOUND FRAMING MEMBER.

NOTICE

IF REAR BACK HANGS ARE TO BE INSTALLED OVER DRYWALL, USE TWO 5/16" X 2" HEX-HEAD LAG SCREWS AND MAKE SURE LAG SCREWS ENGAGE INTO SOLID STRUCTURAL LUMBER.

DANGER

FAILURE TO ASSEMBLE AND ATTACH REAR BACK HANGS PROPERLY ACCORDING TO THE ABOVE INSTRUCTIONS MAY RESULT IN DOOR FALLING WHEN RAISED, CAUSING DEATH OR SERIOUS INJURY.

NOTICE

PERFORATED ANGLE MUST BE ATTACHED TO SOUND FRAMING MEMBERS AND NAILS SHOULD NOT BE USED.

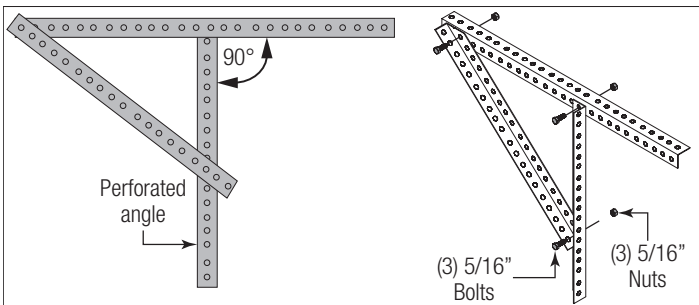

Figure B56

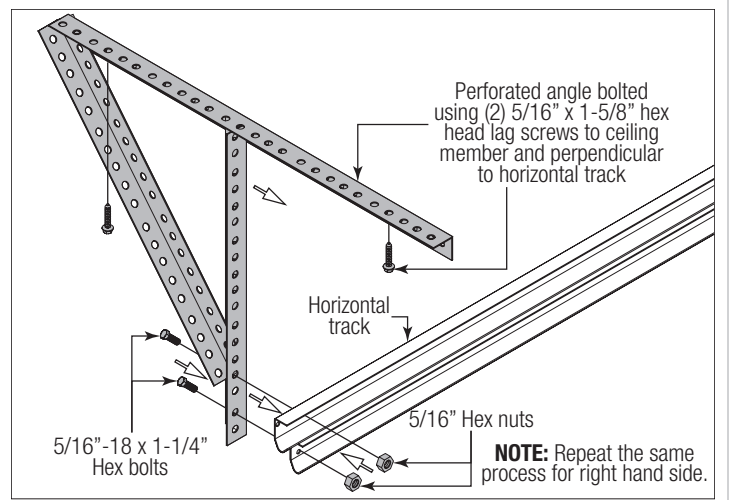

Figure B57

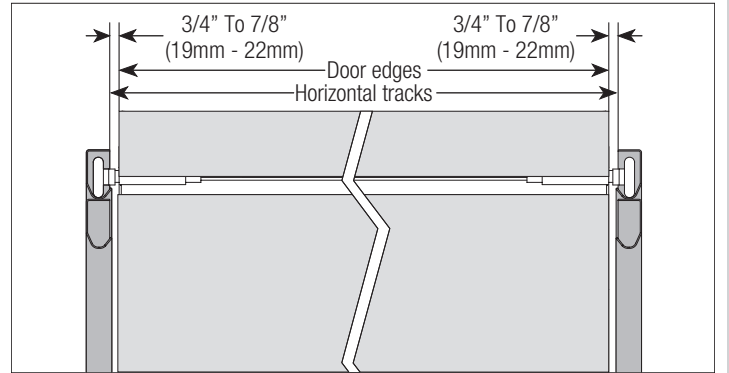

Figure B58

B10 ATTACHING WEATHERSTRIPS (NOT INCLUDED)

NOTE: Complete Step A10 now to permanently attach the weatherstrips, then proceed to Step B11.

B11 BALANCING DOOR

NOTE: Complete Step A11 to balance the door.

OPTIONAL INSTALLATION

Inside Lock

Install the inside lock on the second section of the door. Secure the lock to the section with (4) 1/4" - 20 x 11/16" self drilling screws. Square the lock assembly with the door section, and align with the square hole in the vertical track. The inside lock should be spaced approximately 1/8" away from the section edge.

IMPORTANT: Inside lock(s) must be removed or made inoperative in the unlocked position if an operator is installed on this door.

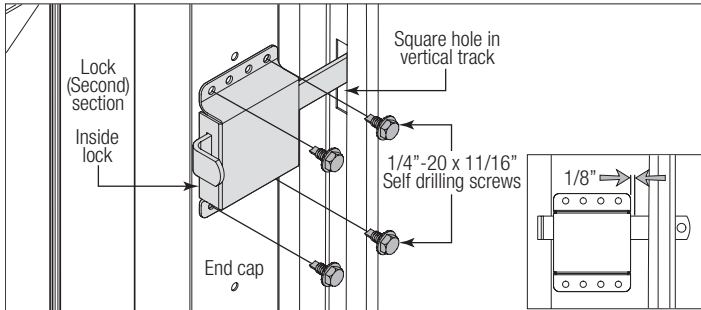

Pull Down Rope

WARNING

DO NOT INSTALL PULL DOWN ROPE ON DOORS WITH OPERATORS. CHILDREN MAY BECOME ENTANGLED IN THE ROPE CAUSING SEVERE OR FATAL INJURY.

Measure and mark the jamb approximately 48" to 50" (1220 to 1270 mm) from floor on the right or left side of jamb. Drill 1/8" pilot hole for no. 6 screw eye. Tie the pull down rope to the no. 6 screw eye and to the bottom corner bracket, as shown.

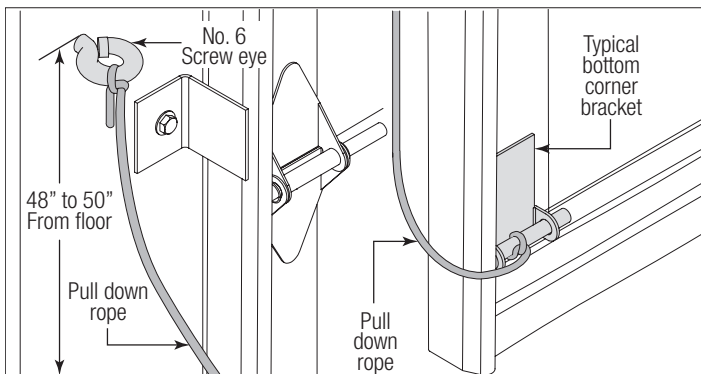

Cleaning Your Garage Door

NOTICE

DO NOT USE A PRESSURE WASHER ON YOUR GARAGE DOOR!

While factory-applied finishes on garage doors are durable, it is desirable to clean them on a routine basis. Some discoloration of the finish may occur when a door has been exposed to dirt-laden atmosphere for a period of time. Slight chalking may also occur as a result of direct exposure to sunlight. Cleaning the door may help to restore the appearance of the finish. To maintain an aesthetically pleasing finish of the garage door, a periodic washing of the garage door is recommended.

The Following Cleaning Solution is Recommended:

A mild detergent solution consisting of one cup detergent (with less than 0.5% phosphate) dissolved into five gallons of warm water will aid in the removal of most dirt.

NOTICE

THE USE OF DETERGENTS CONTAINING GREATER THAN 0.5% PHOSPHATE IS NOT RECOMMENDED FOR USE IN GENERAL CLEANING OF GARAGE DOORS. BE SURE TO CLEAN BEHIND WEATHER-STRIPS ON BOTH SIDES AND TOP OF DOOR.

NOTICE

NEVER MIX CLEANSERS OR DETERGENTS WITH BLEACH.

NOTICE

DO NOT USE ANY WINDOW CLEANING FLUIDS, SCOURING COMPOUNDS, GRITTY CLOTHS OR SOLVENT-BASED CLEANERS OF ANY KIND.

To clean polycarbonate windows, see www.Wayne-Dalton.com.

Painting Your Garage Door

Refer to Instruction Insert "**Field Painting and Finishing Fiberglass or Steel Door Sections**".

Maintaining The Finish On Your Garage Door

If the factory finish is beginning to fade, the door may require a field applied top clear coat. Depending on environment and usage, this may be necessary after 1 to 3 years of use. Refer to Instruction Insert "**Field Painting and Finishing Fiberglass or Steel Door Sections**".

Operation And Maintenance

Operating Your Garage Door:

Before you begin, read all warning labels affixed to the door and the installation instructions and owner's manual. When correctly installed, your Wayne Dalton door will operate smoothly. Always operate your door with controlled movements. Do not slam your door or throw your door into the open position, this may cause damage to the door or its components. If your door has an electric opener, refer to the owner's manual to disconnect the opener before performing manual door operation below.

Manual Door Operation:

For additional information on manual garage door operation go to www.dasma.com and reference TDS 165.

CAUTION

DO NOT PLACE FINGERS OR HANDS INTO SECTION JOINTS WHEN OPENING AND/OR CLOSING A DOOR. ALWAYS USE LIFT HANDLES/SUITABLE GRIPPING POINTS WHEN OPERATING THE DOOR MANUALLY.

OPENING A DOOR: Make sure the lock (if present) are in the unlocked position. Lift the door by using the lift handles/suitable gripping points only. Door should open with little resistance.

CLOSING A DOOR: From inside the garage, pull door downward using lift handles/gripping points only. If you are unable to reach the lift handles/suitable gripping points only, use pull-down rope (if present) affixed to the side of door. Door should close completely with little resistance.

Using An Electric Operator:

IMPORTANT: If present, Pull-down rope must be removed and locks must be removed or made inoperative in the unlocked position.

When connecting a drawbar (trolley-type) garage door operator to this door, a drawbar operator bracket must be securely attached to the top section of the door, along with any struts provided with the door. Always use the drawbar operator bracket supplied with the door. To avoid possible damage to your door, reinforce the top section with a strut (may or may not be supplied). The installation of the drawbar operator must be according to manufacturer's instructions and force settings must be adjusted properly. Refer to the owner's manual supplied with your drawbar operator for complete details on installation, operation, maintenance and testing of the operator.

Maintaining Your Garage Door:

Before you begin, read all warning labels affixed to the door and the installation instructions and owner's manual. Perform routine maintenance steps once a month, and have the door professionally inspected once a year. Review your Installation Instructions and Owner's Manual for the garage door. These instructions are available at no charge from Wayne Dalton, a division of Overhead Door Corporation, P.O. Box 67, Mt. Hope, OH, 44660, or at www.Wayne-Dalton.com. For additional information on garage door/operator maintenance go to www.dasma.com and reference TDS 151, 167 and 179.

Monthly Inspections:

1. Visual Inspection:

Closely inspect jambs, header and mounting surface. Any material found not to be structurally sound must be replaced. It may be necessary to uninstall part or all of the door assembly in order to replace defective material. Refer to the supplemental instructions "Removing an Existing Door/Preparing the Opening" at www.Wayne-Dalton.com. Inspect the spring(s), counterbalance lift cables, track rollers, pulleys, rear back hangs and other door hardware for signs of worn or broken parts. Tighten any loose screws and/or bolts, except on bottom corner brackets or on the counterbalance assembly. Check exterior surface of the door sections for any minor cracks. Verify door has not shifted right or left in the opening. If you suspect problems, contact a trained door system technician.

DANGER

GARAGE DOOR SPRINGS, COUNTERBALANCE LIFT CABLES, BRACKETS, AND OTHER HARDWARE ATTACHED TO THE SPRINGS ARE UNDER EXTREME TENSION, AND IF HANDLED IMPROPERLY, CAN CAUSE DEATH OR SERIOUS INJURY. ONLY A TRAINED DOOR SYSTEMS TECHNICIAN SHOULD ADJUST THEM, BY CAREFULLY FOLLOWING THE MANUFACTURER'S INSTRUCTIONS.

WARNING

NEVER REMOVE, ADJUST, OR LOOSEN THE BOLTS, SCREWS AND/OR LAG SCREWS ON THE COUNTERBALANCE (END BEARING BRACKETS, DRUMS OR SPRING SYSTEM) OR BOTTOM CORNER BRACKETS OF THE DOOR. THESE BRACKETS ARE CONNECTED TO THE SPRING(S) AND ARE UNDER EXTREME TENSION. TO AVOID POSSIBLE DEATH OR SERIOUS INJURY, HAVE ANY SUCH WORK PERFORMED BY A TRAINED DOOR SYSTEMS TECHNICIAN USING PROPER TOOLS AND INSTRUCTIONS.

Torsion Springs:

The torsion springs (located above the door) should only be adjusted by a trained door systems technician. **DO NOT** attempt to repair or adjust torsion springs yourself.

2. Door Balance:

Periodically test the balance of your door. If you have a garage door drawbar operator, use the release mechanism so you can operate the door by hand when doing this test. Start with the door in the fully closed position. Using handles or suitable gripping points, lift the door to check its balance. If door lifts by itself (hard to pull down) or if door is difficult to lift (easy to pull down), have it adjusted by a trained door systems technician. **DO NOT** attempt to repair or adjust Torsion Springs yourself.

3. Lubrication:

The door should open and close smoothly. Ensure the door track rollers are rotating freely when opening and closing the door. If track rollers do not rotate freely, clean the door tracks, removing dirt and any foreign substances. Clean and lubricate (use a non-silicon based lubricant) graduated end hinges, center hinges, steel track rollers, bearings and torsion springs (torsion spring coil surfaces). **DO NOT** lubricate plastic idler bearings, nylon track rollers, or the door track. **DO NOT** oil a cylinder lock. If actuation is difficult, use a graphite dust to lubricate.

Check for Presence of Safety Labels:

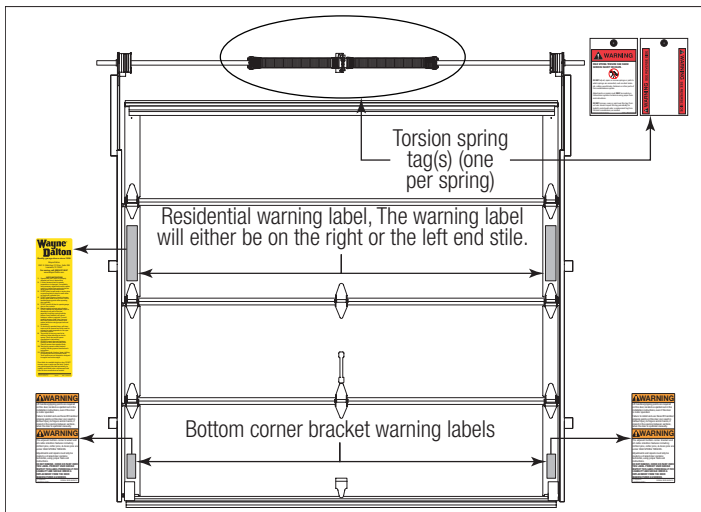



Models 8000, 8200, 8024 PO, & 8224 PO

Limited Warranty

Wayne Dalton, a division of Overhead Door Corporation ("Seller") warrants to the original purchaser of the Models 8000, 8200, 8024 PO, 8224 PO ("Product"), subject to all of the terms and conditions hereof, that the Product and all components thereof will be free from defects in materials and workmanship for the following period(s) of time, measured from the date of installation:

TEN (10) YEARS from the date of installation against:

- The Product becoming inoperable due to rust-through of the steel skin from the core of the Product section, due to cracking, splitting, or other deterioration of the steel skin, or due to structural failure caused by separation or degradation of the foam insulation.
- Peeling of the original paint as a result of a defect in the original paint or in the application of the original paint coating.

TEN (10) YEARS on Product hardware and tracks (except springs).

ONE (1) YEAR on all other component and parts.

Seller's obligation under this warranty is specifically limited to repairing or replacing, at its option, any part which is determined by Seller to be defective during the applicable warranty period. Any labor charges are excluded and will be the responsibility of the purchaser.

This warranty gives you specific legal rights, and you may also have other rights which vary from state to state. This warranty is made to the original purchaser of the Product only, and is not transferable or assignable. This warranty applies only to Product installed in a residential or other non-commercial application. It does not cover any Product installed in commercial or industrial building applications. This warranty does not apply to any unauthorized alteration or repair of the Product, or to any Product or component which has been damaged or deteriorated due to misuse, neglect, accident, failure to provide necessary maintenance, normal wear and tear, acts of God, or any other cause beyond the reasonable control of Seller or as a result of having been exposed to toxic or abrasive environments, including blowing sand, salt water, salt spray and toxic chemicals and fumes.

ALL EXPRESS AND IMPLIED WARRANTIES FOR THE PRODUCT, INCLUDING BUT NOT LIMITED TO ANY IMPLIED WARRANTIES OF MERCHANTABILITY AND FITNESS FOR A PARTICULAR PURPOSE, ARE LIMITED IN TIME TO THE APPLICABLE WARRANTY PERIOD REFLECTED ABOVE. NO WARRANTIES, WHETHER EXPRESS OR IMPLIED, WILL APPLY AFTER THE LIMITED WARRANTY PERIOD HAS EXPIRED. Some states do not allow limitations on how long an implied warranty lasts, so the above limitation may not apply to you.

IN NO EVENT SHALL SELLER BE RESPONSIBLE FOR, OR LIABLE TO ANYONE FOR, SPECIAL, INDIRECT, COLLATERAL, PUNITIVE, INCIDENTAL OR CONSEQUENTIAL DAMAGES, even if Seller has been advised of the possibility of such damages. Such excluded damages include, but are not limited to, loss of use, cost of any substitute product, or other similar indirect financial loss. Some states do not allow the exclusion or limitation of incidental or consequential damages, so the above limitation or exclusion may not apply to you.

Claims under this warranty must be made promptly after discovery, within the applicable warranty period, and in writing to the authorized distributor or installer whose name and address appear below. The purchaser must allow Seller a reasonable opportunity to inspect any Product claimed to be defective prior to removal or any alteration of its condition. Proof of the purchase and/or installation date, and identification as the original purchaser, may be required. There are no established informal dispute resolution procedures of the type described in the Magnuson-Moss Warranty Act.

SELLER: _____

SELLER'S ADDRESS: _____

Thank you for your purchase.

PLEASE DO NOT RETURN THIS PRODUCT TO THE STORE

If you need assistance, please call 1-866-569-3799 (press Option 1) and follow the prompts to contact a customer service representative. They will be happy to handle any questions that you may have.

After installation is complete, leave this Installation Instructions And Owner's Manual with the homeowner, or fasten it near garage door for easy reference.

Product may be covered by one or more patents.
See **www.wayne-dalton.com/patents** for details.