



INSTALLATION INSTRUCTIONS AND OWNER'S MANUAL

Aluminum Full View Model 8855

RESIDENTIAL
STANDARD LIFT
WINDLOAD
TORSION

DEFINITION OF LIGHT COMMERCIAL:

1. Door heights less than or equal to 8'0" ($\leq 8'0"$) are considered Residential applications.
2. Door heights greater than 8'0" ($> 8'0"$) are considered Light Commercial applications.

PLEASE DO NOT RETURN THIS PRODUCT TO THE STORE

If you need assistance, please call 1-866-569-3799 (press Option 1) and follow the prompts to contact a customer service representative. They will be happy to handle any questions that you may have.

IMPORTANT NOTICES!

Carefully read and fully understand the enclosed instructions before installing and operating the garage door.

Pay close attention to all warnings and notes.

After installation is complete, fasten this manual near garage door for easy reference.

This Installation document is available at no charge from:

- Your local Wayne Dalton Sales Center
- Online at **www.Wayne-Dalton.com**
- By mailing a request to: Wayne Dalton, a division of Overhead Door Corporation, P.O. Box 67, Mt. Hope, OH., 44660

Table Of Contents

PRE-INSTALLATION	3
Important Safety Instructions	3
REMOVING AN EXISTING DOOR AND PREPARING THE OPENING	5
Package Contents	6
Door Section Identification	8
Tools Required	9
BREAKDOWN OF DOOR COMPONENTS	10
BREAKDOWN OF COUNTERBALANCE COMPONENTS	11
INSTALLATION INSTRUCTIONS	12
Door Installation Instructions	12
COUNTERBALANCE INSTALLATION INSTRUCTIONS	23
OPTIONAL INSTALLATION	33
Inside Lock	33
Step Plate	33
Exhaust Port	33
Chain Hoist	33
Pusher Springs	34
MAINTENANCE	35
Cleaning Your Garage Door	35
Operation And Maintenance	35
WARRANTY	37

Important Safety Instructions

DEFINITION OF KEY WORDS USED IN THIS MANUAL:

DANGER

INDICATES A HAZARDOUS SITUATION THAT, IF NOT AVOIDED, WILL RESULT IN DEATH OR SERIOUS INJURY.

WARNING

INDICATES A HAZARDOUS SITUATION THAT, IF NOT AVOIDED, COULD RESULT IN DEATH OR SERIOUS INJURY.

CAUTION

INDICATES A HAZARDOUS SITUATION THAT, IF NOT AVOIDED, COULD RESULT IN MINOR OR MODERATE INJURY.

NOTICE

INDICATES INFORMATION CONSIDERED IMPORTANT, THAT IT IS NOT RELATED TO INJURY, BUT MAY RESULT IN PROPERTY DAMAGE.

IMPORTANT: Required key step for proper door operation.

NOTE: Information only.

Installation:

WARNING

INSTALLING THIS DOOR PROPERLY REQUIRES THE USE OF SPECIAL TOOLS AND TECHNIQUES. ALWAYS USE THE CORRECT TOOLS OR TECHNIQUES WHEN PERFORMING INSTALLATION. FAILURE TO USE PROPER TOOLS OR TECHNIQUES OR ADHERE TO SAFETY MESSAGES, COULD RESULT IN SEVERE OR FATAL INJURY.

DANGER

EXTREME CAUTION SHOULD BE USED WHEN WINDING SPRINGS AS FAILURE TO FOLLOW THE INSTRUCTIONS OR USE THE PROPER TOOLS CAN LEAD TO SERIOUS INJURY TO PERSONS AND PROPERTY. BEFORE ATTEMPTING TO WIND THE SPRING, MAKE SURE YOU HAVE READ AND UNDERSTAND THE INSTRUCTIONS. IF YOU ARE UNCLEAR ON ANY ASPECT OF THE INSTALLATION PROCEDURES, YOU SHOULD CONSULT A TRAINED DOOR SYSTEMS TECHNICIAN.

- READ THESE INSTRUCTIONS CAREFULLY BEFORE ATTEMPTING INSTALLATION. IF YOU ARE IN QUESTION ABOUT ANY OF THE PROCEDURES, DO NOT PERFORM THE WORK. INSTEAD, HAVE A TRAINED DOOR SYSTEMS TECHNICIAN DO THE INSTALLATION OR REPAIRS.
- Wear protective gloves and eye protection during installation, to avoid possible injury.
- **DO NOT** install door in windy conditions. Door could fall during the installation, causing severe or fatal injury.
- Doors 12'-0" wide and larger should be installed by two persons, to avoid possible injury.
- On electrically operated doors, pull down ropes must be removed and locks must be removed or made inoperative in the open (unlocked) position, unless electrical interlocks are installed.
- Impact guns are not recommended. When installing 5/16" lag screws using an electric drill/ driver, the drill/ drivers clutch must be set to deliver no more than 200 in-lbs of torque. Fastener failure could occur at higher settings.
- Check with your local building official for wind load code requirements and building permit information.
- For windloaded doors, the wind performance is achieved via the entire door system and component substitution is not authorized without express permission by the manufacturer.

CAUTION



IF ANY PART OF THE DOOR IS TO BE INSTALLED ONTO PRESERVATIVE-TREATED WOOD, PTFE-COATED OR STAINLESS STEEL FASTENERS MUST BE OBTAINED AND USED. REPLACEMENT FASTENERS MUST BE OF AT LEAST EQUAL STRENGTH AND SIZE AS ORIGINAL FASTENERS. IF THE ORIGINAL FASTENER WAS RED-HEAD, THE REPLACEMENT FASTENER MUST BE RED-HEAD ALSO. CONTACT WAYNE DALTON FOR FASTENER STRENGTH VALUES IF NEEDED.

Operation:

⚠ WARNING

TO PREVENT DEATH OR SERIOUS INJURY WHILE OPERATING THE DOOR, ENSURE THE PATH OF THE DOOR IS NOT OBSTRUCTED BY ANY PERSON OR OBJECT AND ADHERE TO THE FOLLOWING SAFETY MEASURES.

- Operate door only when it is properly adjusted and free from obstructions.
- If a door becomes hard to operate, inoperative or is damaged, immediately have necessary adjustments and/ or repairs made by a trained door system technician using proper tools and instructions.
- **DO NOT** stand or walk under a moving door, or permit anybody to stand or walk under an electrically operated door.
- **DO NOT** place fingers or hands into open section joints when closing a door. Use lift handles/ gripping points when operating door manually.
- **DO NOT** permit children to operate garage door or door controls. Severe or fatal injury could result should the child become entrapped between the door and the floor.
- Visually inspect door and hardware monthly for worn and or broken parts. Check to ensure door operates freely. Test electric opener's safety features monthly, following opener manufacturer's instructions.
- **NEVER** hang tools, bicycles, hoses, clothing or anything else from horizontal tracks. Track systems are not intended or designed to support extra weight.

Potential Hazard	Effect	Prevention
 <p>Moving door</p>	<p>⚠ WARNING</p> <p>Could result in Death or Serious Injury</p>	<p>Keep people clear of opening while Door is moving.</p> <p>Do NOT allow children to play with the Door Opener.</p> <p>Do NOT operate a Door that jams or one that has a broken spring.</p>
 <p>High tension spring</p>	<p>⚠ DANGER</p> <p>Will result in Death or Serious Injury</p>	<p>Do NOT try to remove, install, repair or adjust springs or anything to which door spring parts are fastened, such as, wood blocks, steel brackets, cables or other like items.</p> <p>Installations, repairs and adjustments must be done by a trained door system technician using proper tools and instructions.</p>

IMPORTANT: RIGHT and LEFT hand is determined inside the building looking out.

REMOVING AN EXISTING DOOR AND PREPARING THE OPENING

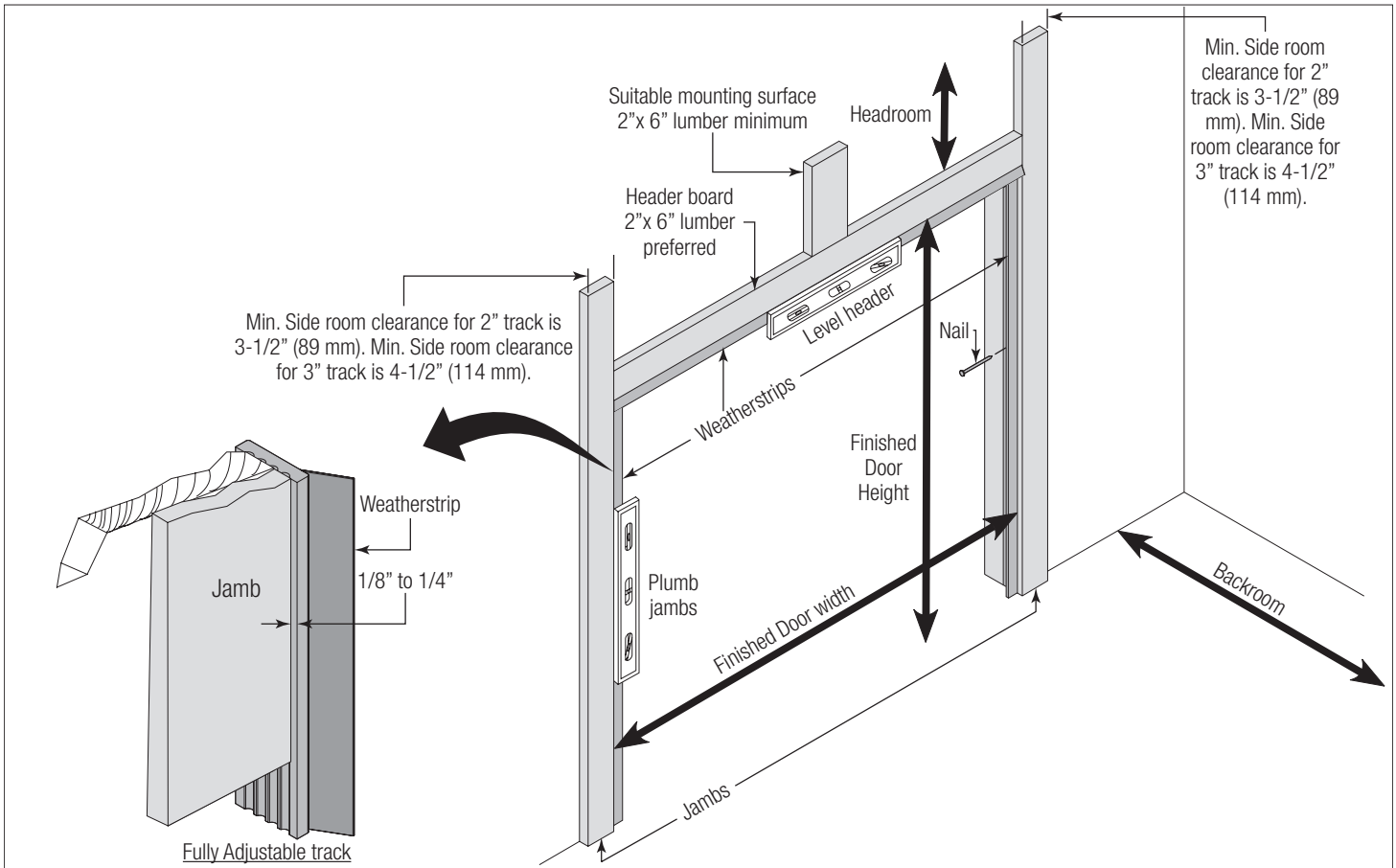

Figure 1

! DANGER

AVOID INJURY! A POWERFUL SPRING RELEASING ITS ENERGY SUDDENLY CAN CAUSE SEVERE OR FATAL INJURY. ALWAYS HAVE A TRAINED DOOR SYSTEMS TECHNICIAN, USING PROPER TOOLS AND INSTRUCTIONS, RELEASE THE SPRING TENSION.

! WARNING

TO AVOID POSSIBLE INJURY AND TO ENSURE PROPER INSTALLATION, IT'S HIGHLY RECOMMENDED THAT YOU READ AND FULLY UNDERSTAND THE COMPLETE INSTRUCTIONS ON REMOVING AN EXISTING DOOR & PREPARING THE OPENING. THESE ARE AVAILABLE FOR DOWNLOAD AT WWW.WAYNE-DALTON.COM OR AT YOUR LOCAL WAYNE DALTON SALES CENTER.

! DANGER

COUNTERBALANCE SPRING TENSION MUST ALWAYS BE RELEASED BEFORE ANY ATTEMPT IS MADE TO START REMOVING AN EXISTING DOOR. EXTREME CAUTION SHOULD BE USED WHEN UNWINDING SPRINGS AS FAILURE TO FOLLOW THE INSTRUCTIONS OR USE PROPER TOOLS CAN LEAD TO SERIOUS INJURY.

See Figure 1 for the following steps.

To ensure secure mounting of track brackets, side and center brackets, or steel angles to new or retro-fit construction, it is recommended to follow the procedures outlined in DASMA technical data sheets #156, #161 and #164 at www.dasma.com.

- The inside perimeter of your garage door opening should be framed with wood jamb and header material.
- The jambs and header must be securely fastened to sound framing members. It is recommended that 2" x 6" lumber be used. The jambs must be plumb and the header level.
- The jambs should extend a minimum of 12" (305 mm) above the top of the opening for Torsion counterbalance systems.
- For low headroom applications, the jambs should extend to the ceiling height.
- Minimum side clearance required, from the opening to the wall, is 3-1/2" (89 mm), for 2" track. Minimum side clearance required, from the opening to the wall, is 4-1/2" (114 mm), for 3" track.

NOTICE

CLOSELY INSPECT JAMBS, HEADER AND MOUNTING SURFACE. ANY WOOD FOUND NOT TO BE SOUND, MUST BE REPLACED.

For Torsion counterbalance systems, a suitable mounting surface (2" x 6") must be firmly attached to the wall, above the header at the center of the opening.

NOTICE

DRILL A SUITABLE PILOT HOLE IN THE MOUNTING SURFACE TO AVOID SPLITTING THE LUMBER. DO NOT ATTACH THE MOUNTING SURFACE WITH NAILS.

Weatherstrips (Not Included):

Depending on the size of your door, you may have to cut or trim the weatherstrips to properly fit into the header and jambs.

NOTICE

IF NAILING PRODUCT AT 40°F, (4.4°C) OR BELOW, PRE-DRILLING IS REQUIRED.

1. For the header, align the weatherstrip with the inside edge of the header and temporarily secure it to the header with equally spaced nails, approximately 12" to 18" (305 mm - 457 mm) apart.

2. Starting at either side of the jamb, fit the weatherstrip up tight against the temporarily attached weatherstrip in the header and flush with the inside edge of the jamb.

3. Temporarily secure the weatherstrip with equally spaced nails. Repeat for other side. This will keep the bottom door section from falling out of the opening during installation.

Headroom requirement:

Headroom required is defined as the space needed above the top of the door for tracks, springs, etc. to allow the door to open properly.

NOTE: 6" low headroom conversion kit is available for 12" radius only. Contact your local Wayne Dalton dealer.

If the door is to be motor operated, 2-1/2" (64 mm) of additional headroom is required.

TRACK TYPE	SPACE NEEDED
12" Radius	13-1/2" (343 mm)
15" Radius	14-1/2" (368 mm)

Backroom requirement:

Backroom required is defined as the distance needed from the opening back into the garage to allow the door to open fully.

***NOTE:** For door heights from 10'1" to 14'0", refer to your operator manufacture installation instructions for appropriate depth into room.

DOOR HEIGHT	TRACK	MANUAL LIFT	MOTOR OPERATED
6'0" to 7'0"	12",15" Radius	102" (2591 mm)	125" (3175 mm)
7'1" to 8'0"	12",15" Radius	114" (2896 mm)	137" (3480 mm)
8'1" to 9'0"	12",15" Radius	126" (3200 mm)	168" (4267 mm)
9'1" to 10'0"	12",15" Radius	138" (3505 mm)	168" (4267 mm)
10'1" to 12'0"	12",15" Radius	162" (4115 mm)	See *NOTE
12'1" to 14'0"	12",15" Radius	186" (4724 mm)	See *NOTE

Package Contents

NOTE: Depending on the door model, some parts listed may not be required, and will not be supplied.

Components and Hardware

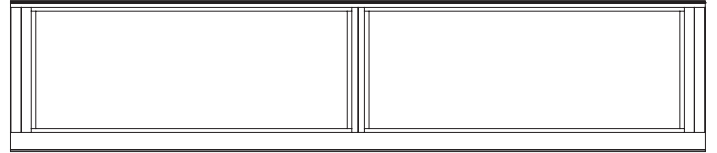

(E1. - E4.) Door sections (as required)



(L9.) Torsion shaft / Torsion keyed shaft (as required)



(L10.) Torsion keyed shafts (as required)

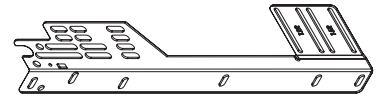

(A1.) Fully Adjustable flag angles RH/LH (as required)

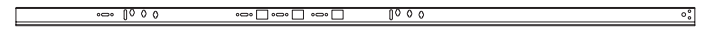

(H2.) Vertical tracks RH/LH (as required)



(H3.) Riveted vertical track assemblies RH/LH (as required)



(H4.) Angle mount vertical track assemblies RH/LH (as required)



(H1.) Horizontal tracks

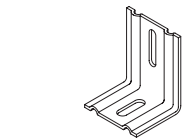

(B1.) F.A. Jamb brackets (as required)

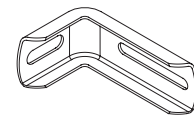

(B2.) Windload jamb brackets (as required)

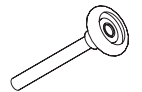

(C1.) (C2.) Track rollers

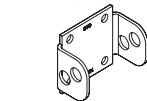

(J1.) Track roller carriers (if included)

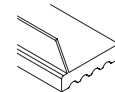

Weather seals & nails (if included)



Wall angle seals (as required)



Pull Down rope (if included)

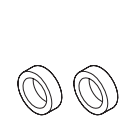

(2) Spacers (as required)



Clevis pin (as required)



Cotter pin (as required)

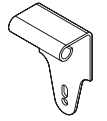

Step plates (if included)

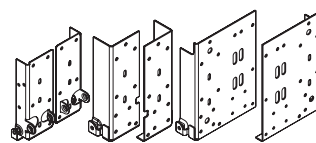

(I1.) Bottom corner brackets (as required)

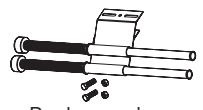

Pusher springs (if included)

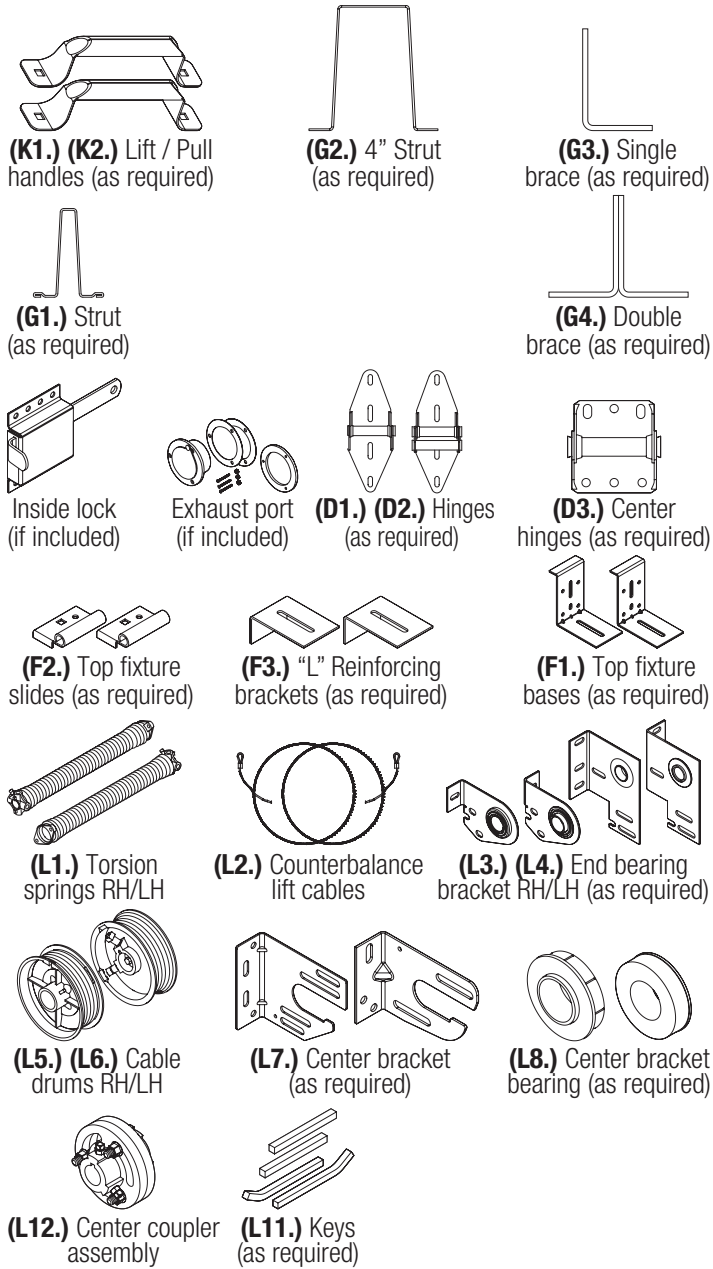
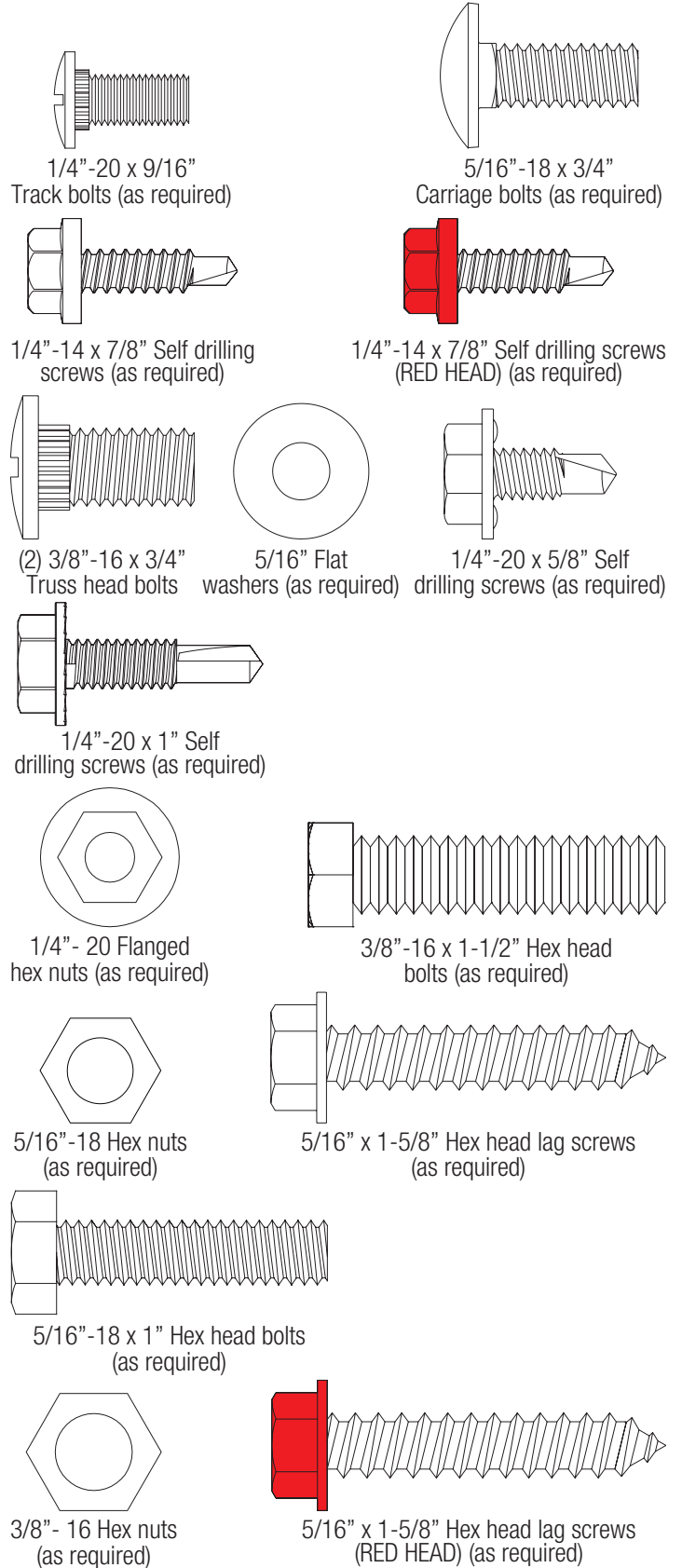
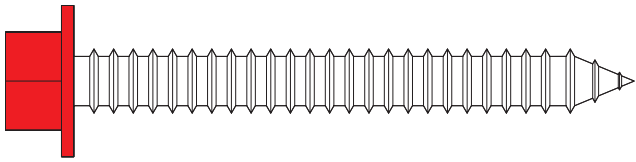

Figure 2

Fasteners





5/16" x 2-1/2" Hex head lag screws (RED HEAD) (as required)

Figure 3

Door Section Identification

See Figure 4 and Figure 7 for the following steps.

Type Of Sections	
How Many Sections High	Type Of Section
10	Top Section
9	Intermediate Section VII (As Required)
8	Intermediate Section VI (As Required)
7	Intermediate Section V (As Required)
6	Intermediate Section IV (As Required)
5	Intermediate Section III (As Required)
4	Intermediate Section II (As Required)
3	Intermediate Section I (As Required)
2	Lock Section
1	Bottom Section

When installing your door you must use sections of the appropriate height in the right stacking order. What sections heights you need to use in what order depends on the height of your door. Sections are either 24", 21" or 19-1/2" in Section Height.

NOTE: If you have different sections heights, the tallest (24" / 21") sections heights are always stacked at the bottom and the smaller 21" / 19-1/2" sections height stacked to the top.

Unless your door is three sections height, you will not receive an Intermediate I section.

When installing your door you must use sections of the appropriate height in the right stacking order. What sections heights you need to use in what order depends on the height of your door.

The **BOTTOM SECTION** can be identified by the factory attached bottom weather seal and by the bottom corner bracket warning labels on each end stile.

The **INTERMEDIATE SECTION I** can be identified by the warning label attached to either the right or left hand end stile.

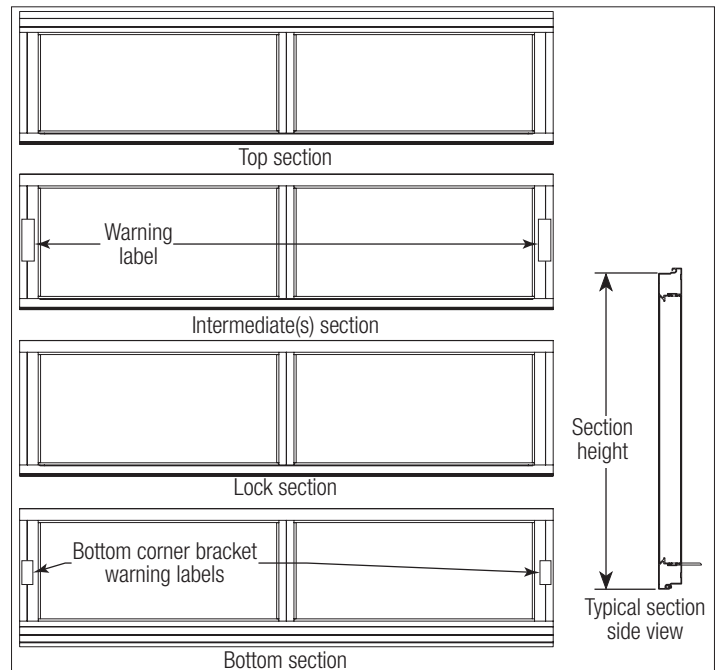

Figure 4

Tools Required

Personal Protection Equipment (PPE)



Figure 5

Hand Tools

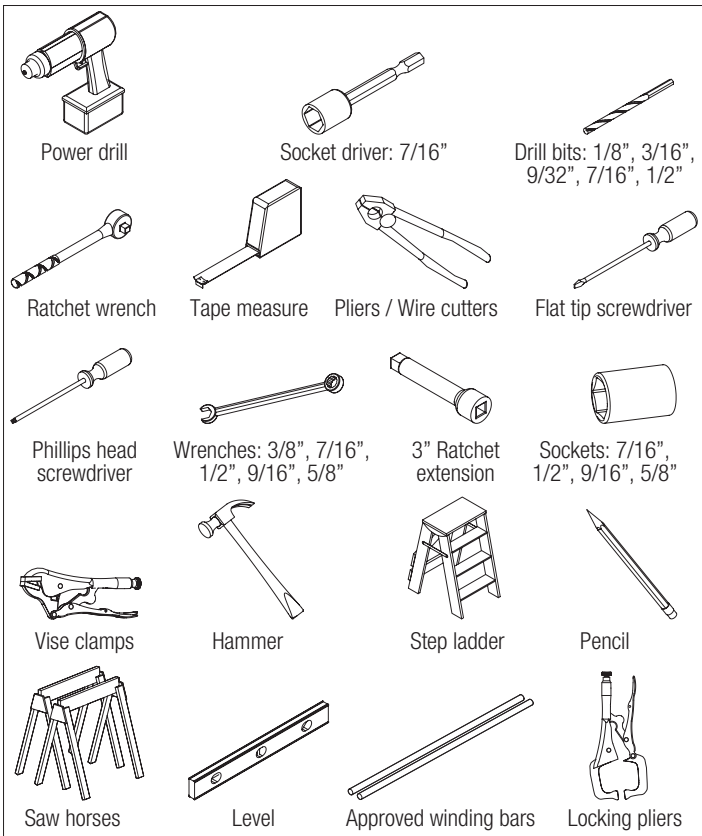

Figure 6

BREAKDOWN OF DOOR COMPONENTS

NOTE: The illustrations shown on this page are general representations of the door parts. Each specific door models may have unique variations.

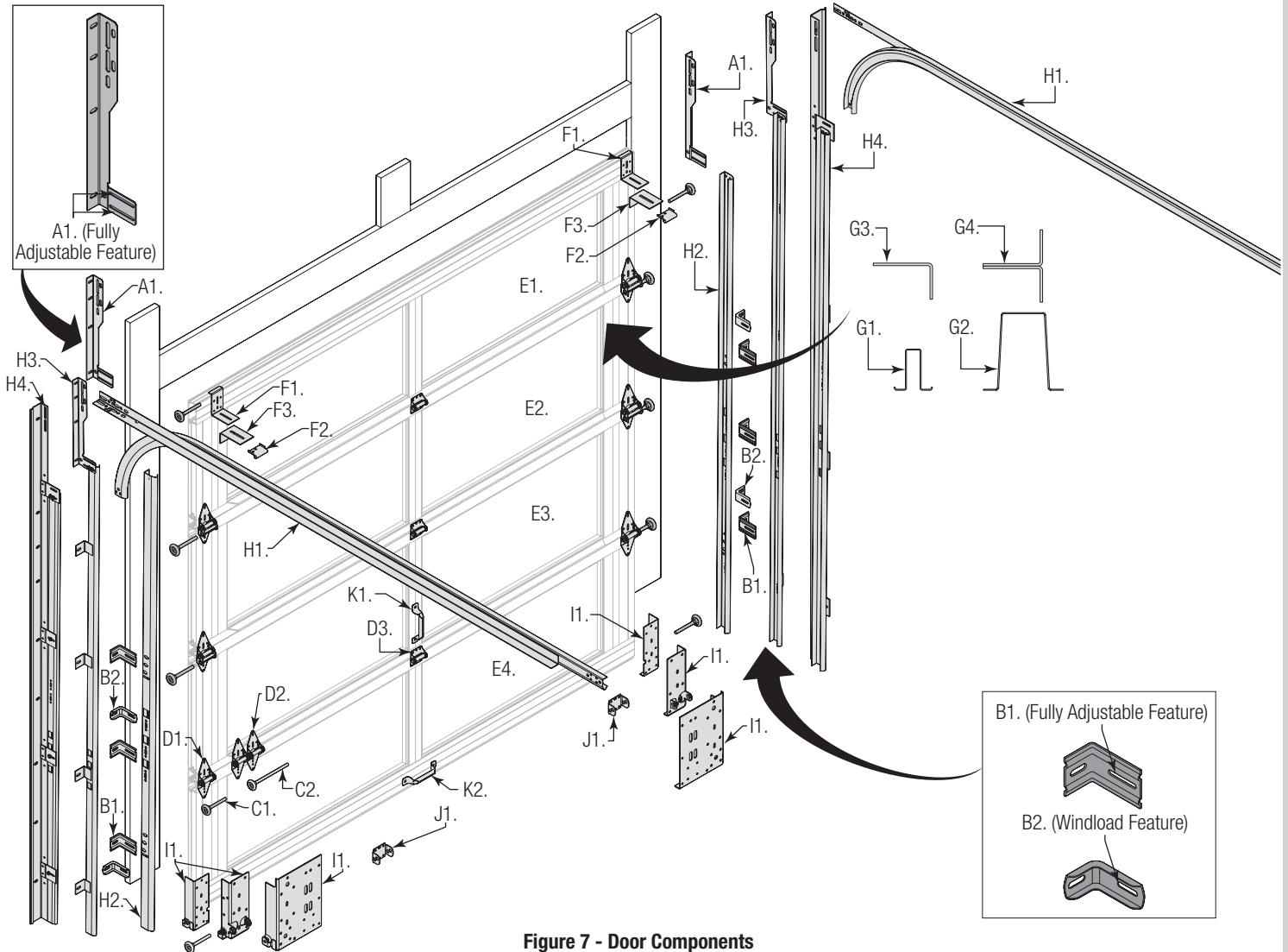

Figure 7 - Door Components

A. FLAG ANGLES (AS REQUIRED):

- A1. Fully Adjustable (F.A.) Flag Angles

B. JAMB BRACKETS (AS REQUIRED):

- B1. Fully Adjustable (F.A.) Jamb Brackets
- B2. Windload Jamb Brackets

C. TRACK ROLLERS (AS REQUIRED):

- C1. Short Stem Track Rollers
- C2. Long Stem Track Rollers

D. GRADUATED END HINGES:

- D1. Single Graduated End Hinges (S.E.H.), Industry Standard
- D2. Double Graduated End Hinges (D.E.H.), Industry Standard
- D3. Center Hinges (As Required)

E. STACKED SECTIONS:

- E1. Top Section
- E2. Intermediate(s) Section
- E3. Lock Section
- E4. Bottom Section

F. TOP FIXTURES:

- F1. Top Fixture Bases

- F2. Top Fixture Slides
- F3. "L" Reinforcing Brackets (As Required)

G. STRUTTING (AS REQUIRED):

- G1. Strut
- G2. 4" Strut
- G3. Single Brace
- G4. Double Brace

H. TRACKS (AS REQUIRED):

- H1. Left Hand and Right Hand Horizontal Track Assemblies
- H2. Left Hand and Right Hand Vertical Tracks
- H3. Left Hand and Right Hand Vertical Track Assemblies
- H4. Left Hand and Right Hand Wall Angle Track Assemblies

I. BOTTOM CORNER BRACKETS (AS REQUIRED):

- I1. Left and Right Hand Bottom Corner Brackets

J. BOTTOM CORNER BRACKET TRACK ROLLER CARRIERS (AS REQUIRED):

- J1. Bottom Corner Bracket Track Roller Carriers

K. HANDLES (AS REQUIRED):

- K1. Lift Handles
- K2. Pull Handles

BREAKDOWN OF COUNTERBALANCE COMPONENTS

NOTE: The illustrations shown on this page are general representations of the door parts. Each specific door models may have unique variations.

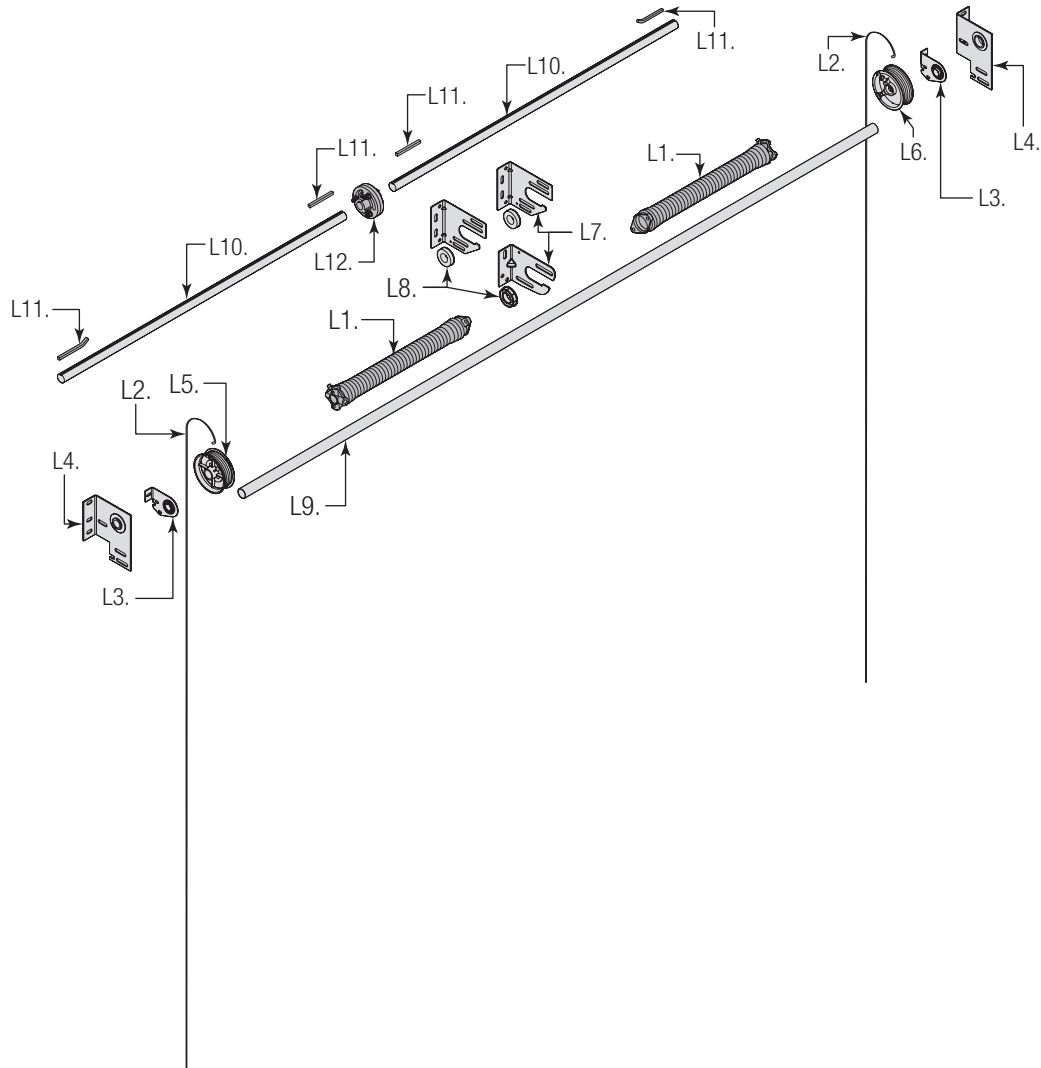

Figure 7 - Counterbalance Components

L. TORSION SPRING ASSEMBLY (AS REQUIRED):

- L1. Left Hand and Right Hand Torsion Springs (As Required)
- L2. Counterbalance Lift Cables
- L3. Left and Right Hand End Bearing Bracket (As Required)
- L4. Left and Right Hand End Bearing Bracket (As Required)
- L5. Left Hand Cable Drum
- L6. Right Hand Cable Drum
- L7. Center Bracket(s) (As Required)
- L8. Center Bracket Bearing(s) (As Required)
- L9. Torsion Shaft / Torsion Keyed Shaft (As Required)
- L10. Torsion Keyed Shafts (As Required)
- L11. Keys (As Required)
- L12. Center Coupler Assembly (As Required)

INSTALLATION INSTRUCTIONS

Door Installation Instructions

BEFORE INSTALLING YOUR DOOR, BE CERTAIN THAT YOU HAVE READ AND FOLLOWED ALL OF THE INSTRUCTIONS COVERED IN THE PRE-INSTALLATION SECTION OF THIS MANUAL. FAILURE TO DO SO MAY RESULT IN AN IMPROPERLY INSTALLED DOOR.

IMPORTANT: Reference TDS 160 for general garage door terminology at www.dasma.com.

NOTICE

IF THE DOOR WILL BE EXPOSED TO A SIGNIFICANT AMOUNT OF ROAD SALT, PAINT THE BOTTOM GALVANIZED STEEL WEATHER RETAINER TO INHIBIT RUSTING.

1 VERTICAL TRACK ASSEMBLY

IMPORTANT: If you have Riveted Track, skip this step.

NOTE: For clarity, all graphics shown are of the left side, right side will be the same.

IMPORTANT: The bottom jamb bracket is always the shortest bracket, while the center jamb bracket is the next tallest. If three jamb brackets per side are included with your door, you will have received a top jamb bracket, which is the tallest.

For Doors With Fully Adjustable Flag Angle:

See Figure 8 and Figure 9 for the following steps.

IMPORTANT: Each flag angle will have a unique ID "12R or 15R". Measure the radius of your horizontal track to determine if your horizontal track is 12" or 15" Radius.

1a. Hand tighten the flag angle ① to the vertical track ② using two 1/4" - 20 x 9/16" track bolts ③ and two 1/4" - 20 flange hex nuts ④.

1b. attach the shortest jamb bracket ⑤ by aligning the slot in the shortest jamb bracket with the lower hole of the hole/ slot pattern of the vertical track. Hand tighten the jamb bracket using (1) 1/4" - 20 x 9/16" track bolt and (1) 1/4" - 20 flange hex nut.

1c. Place the tallest jamb bracket ⑥ over the lower hole of the hole/ slot pattern that is centered between the bottom jamb bracket and flag angle of the 2nd hole set. Hand tighten the jamb bracket using (1) 1/4" - 20 x 9/16" track bolt and (1) 1/4" - 20 flange hex nut.

1d. Repeat this process for the right hand side.

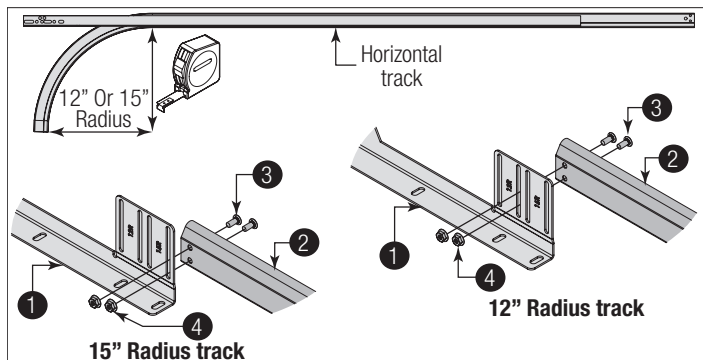

Figure 8, Left Side Shown

IMPORTANT: In Figure 8, observe the slot location in reference to the 12" or 15" radius.

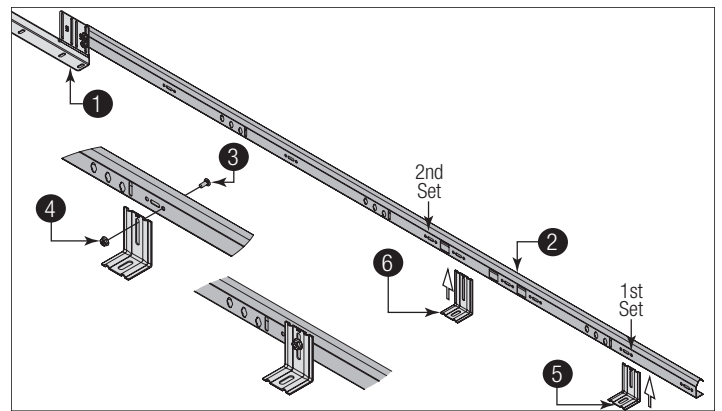

Figure 9, Left Side Shown

1	Flag Angle	4	1/4" - 20 Flange Hex Nut
2	Vertical Track	5	Shortest Jamb Bracket
3	1/4" - 20 x 9/16" Track Bolt	6	Tallest Jamb Bracket

2 ATTACHING (WL) JAMB BRACKETS TO VERTICAL TRACK ASSEMBLY

See Figure 10 for the following steps.

2a. Measure the length of the vertical tracks ①.

2b. Using the Jamb Bracket Schedule (shown on the Windload Specification Sheet included in the hardware box), determine the placement of the windload jamb brackets ② for your door height.

2c. Loosely fasten the jamb bracket to the vertical track using (1) 1/4" - 20 x 9/16" track bolt ③ and (1) 1/4" - 20 flange hex nut ④. Repeat for other windload jamb brackets.

2d. Repeat the same process for the other side.

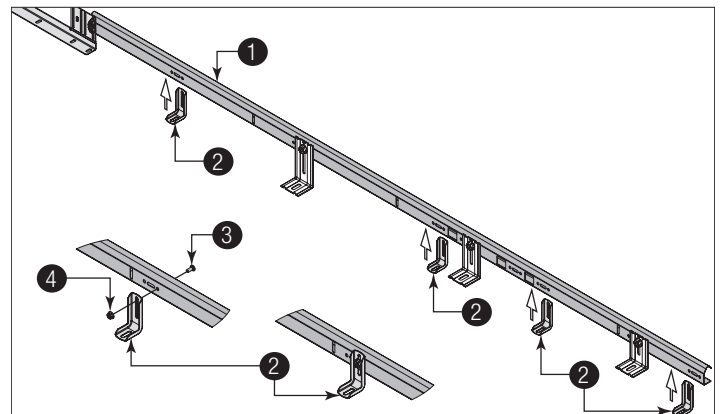

Figure 10, Left Side Shown

1	Vertical Tracks	3	1/4" - 20 x 9/16" Track Bolt
2	Windload Jamb Brackets	4	1/4" - 20 Flange Hex Nut

3 ATTACHING BOTTOM CORNER BRACKETS

IMPORTANT: Refer to door section identification, located in the pre-installation section of this manual or refer to Breakdown of Parts.

NOTE: Refer to door section identification, located in the pre-installation section of this manual. Refer to Package Contents / Breakdown of Parts, to determine which bottom corner brackets you have received.

NOTE: Verify that the bottom weather seal (bottom seal) is aligned with door section. If there is more than 1/2" excess bottom weather seal on either side, trim bottom weather seal **13** even with door section.

NOTE: Refer to the illustrations below or refer to your Windload Specification Sheet to determine if you have single end stiles or double end stiles.

WARNING

ENSURE TIGHT FIT OF CABLE LOOP OVER PIN TO PREVENT COUNTERBALANCE LIFT CABLE FROM COMING OFF THE PIN, WHICH COULD ALLOW THE DOOR TO FALL AND RESULT IN SEVERE OR FATAL INJURY.

See Figure 11 through Figure 15 for the following steps.

3a. Uncoil **1** the counterbalance lift cables **2**.

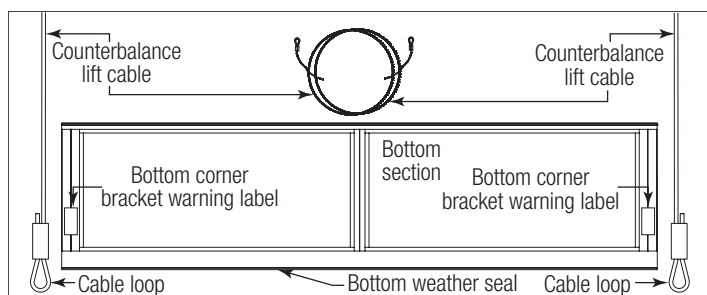

Figure 11

3b. Place the cable loop **3** in between the two holes on the side of the left hand bottom corner bracket **4**.

3c. Slide a clevis pin **5** through the innermost hole, cable loop, and outermost hole, of the bottom corner bracket. Slide a flat washer **6** onto clevis pin.

3d. Secure the clevis pin in place by inserting a cotter pin **7** into the hole of the clevis pin.

3e. Bend the ends **8** of the cotter pin outwards to secure it in place.

3f. Repeat same process for other side.

3g. Align the bottom corner bracket horizontally with the bottom edge of the bottom section **9** and also align the bottom corner bracket vertically with the left bottom edge of the bottom section.

3h. Attach each bottom corner brackets to the bottom section using three 1/4" - 14 x 7/8" RED HEAD self drilling screws **10** and 1/4" - 14 x 7/8" self drilling screws **11**.

3i. Repeat the same process for the right hand bottom corner bracket.

NOTE: If you did not receive Track Roller Carriers, then insert a short stem track roller **12** into each of the bottom corner brackets.

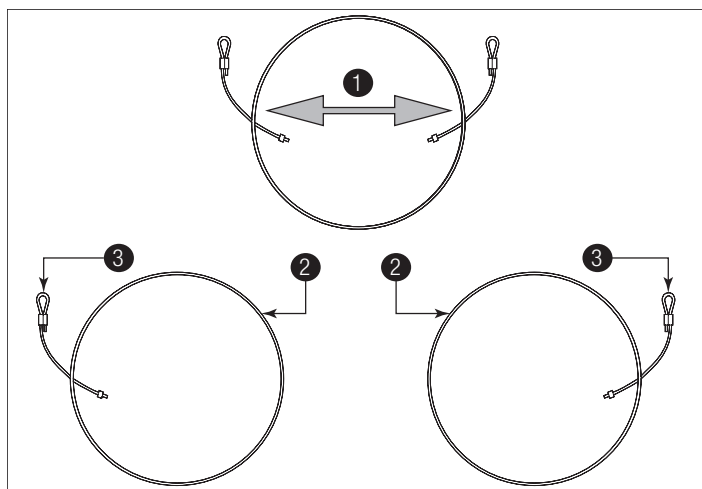

Figure 12, Left Side Shown

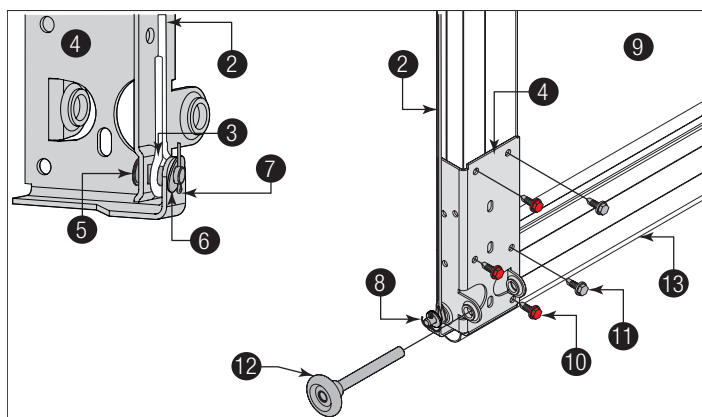

Figure 13, Left Side Shown

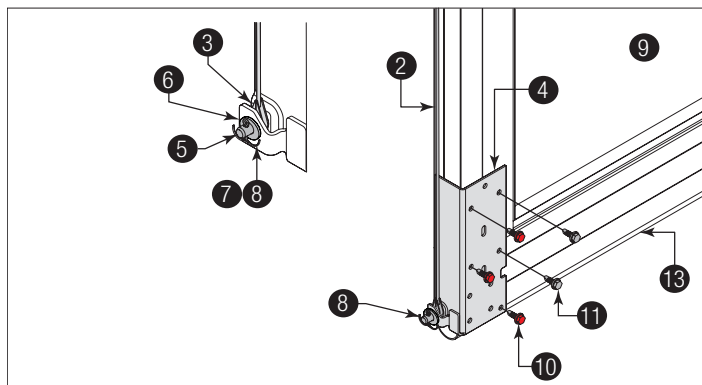

Figure 14, Left Side Shown

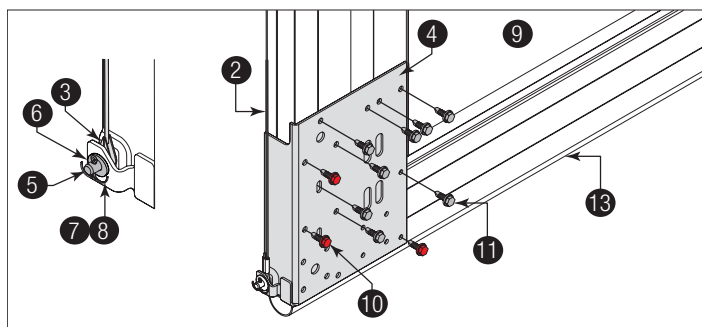

Figure 15, Left Side Shown

1	Uncoil	8	Bend The Ends
2	Counterbalance Lift Cables	9	Bottom Section
3	Cable Loop	10	1/4" - 14 x 7/8" Red Head Self Drilling Screws
4	Bottom Corner Bracket	11	1/4" - 14 x 7/8" Self Drilling Screws
5	Clevis Pin	12	Short Stem Track Roller
6	Flat Washer	13	Bottom Weather Seal
7	Cotter Pin		

NOTE: Refer to your Windload Specification Sheet to determine if a strut or an "L" shaped brace is required to be installed along the bottom rail of the bottom section.

See Figure 16 through Figure 18 for the following steps.

3j. Refer to your Windload Specification Sheet for the placement of your strut (11) or a "L" shaped brace (14) and the required number of 1/4" - 14 x 7/8" self drilling screws (15) to be used to secure the component to the bottom rail (16) of the bottom section.

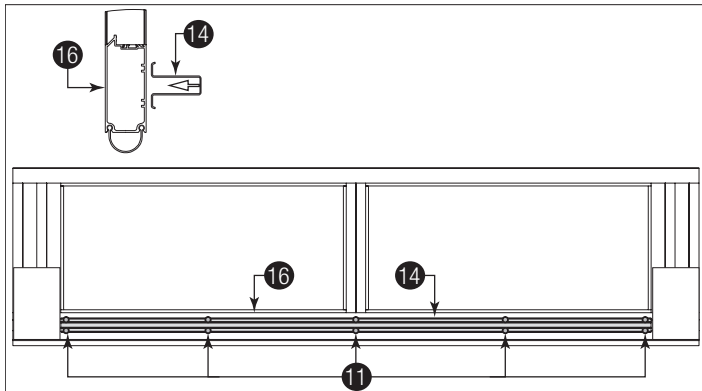

Figure 16

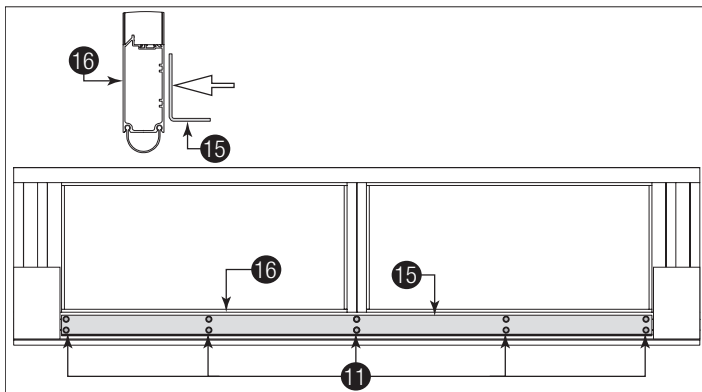

Figure 17

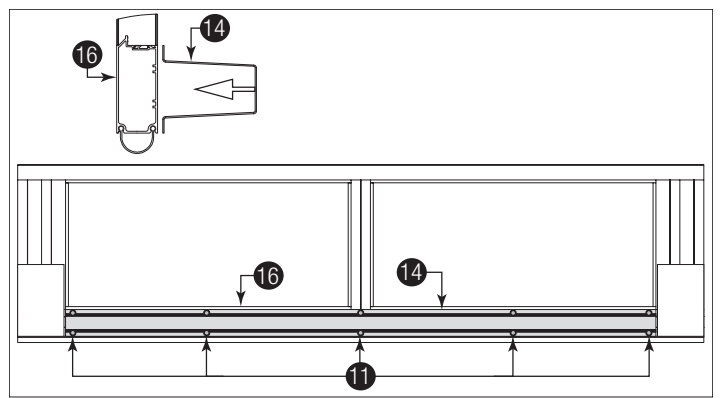

Figure 18

11	1/4" - 14 x 7/8" Self Drilling Screws	15	"L" Shaped Brace
14	Strut	16	Bottom Rail

4 ATTACHING TRACK ROLLER CARRIER'S

IMPORTANT: If you don't have track roller carriers, then skip this step. Refer to Package Contents / Breakdown of Parts, to determine if a track roller carrier was supplied with your door.

IMPORTANT: The track roller carrier's inner holes are used on doors with 2" track applications (1); the outer holes are used on doors with 3" track applications (2).

IMPORTANT: If your door came with two track roller carriers, then one track roller carrier, short stem track roller (3) and a roller spacer (4) are required for each side.

IMPORTANT: If your door came with four track roller carriers, then two track roller carriers, long stem track roller (5) and (4) a roller spacer are required for each side.

See Figure 19 and Figure 20 for the following steps.

4a. Starting on left hand side of the bottom section (5), attach the track roller carrier (6) with the stamp "STD" facing UP (7) to the bottom corner bracket (8) by aligning the four holes of the track roller carrier with the four holes in the bottom corner bracket.

4b. Secure the track roller carrier to the bottom corner bracket with (4) 1/4" - 20 x 1" self drilling screws (10).

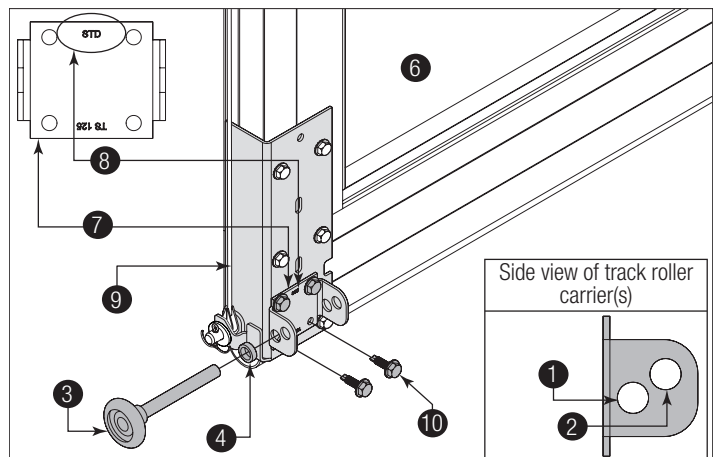

Figure 19, Left Side Shown

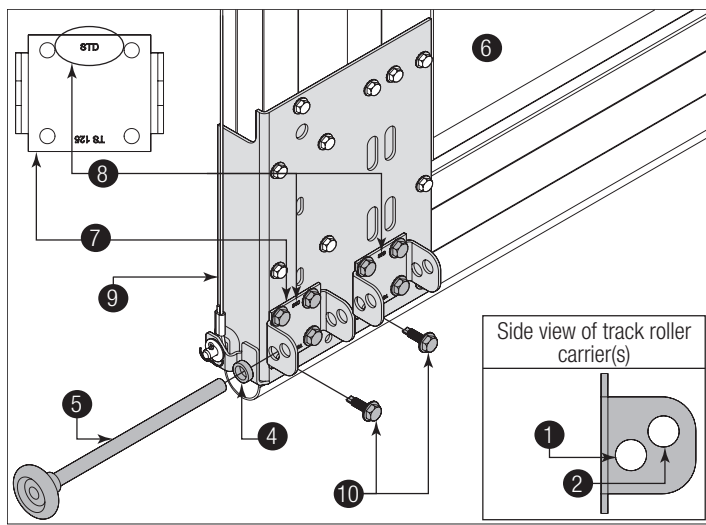

Figure 20, Left Side Shown

1	2" Track Applications	6	Bottom Section
2	3" Track Applications	7	Track Roller Carrier
3	Short Stem Track Roller	8	"Std" Facing Up
4	Roller Spacer	9	Bottom Corner Bracket
5	Long Stem Track Roller	10	1/4" - 20 x 1" Self Drilling Screws

5 ATTACHING HINGES

NOTE: Refer to door section identification, located in the pre-installation section of this manual.

NOTE: The graduated hinges can be identified by the number stamped onto their lower hinge leaf.

NOTE: Refer to your Windload Specification Sheet to determine if you have single end stiles or double end stiles.

IMPORTANT: Once the 1/4" - 14 x 7/8" self drilling screws are snug against the lower hinge leaves, tighten an additional 1/4 to 1/2 turn to receive maximum design holding power.

IMPORTANT: Push & hold the hinge leaf securely against the section while securing with 1/4" - 14 x 7/8" self drilling screws. There should be no gap between the hinge leaf and the section.

IMPORTANT: When placing track rollers into the #2 graduated end hinges and higher, the track roller goes into hinge tube 12 furthest away from section.

Graduated End Hinge Schedule

Section Type	Graduated End hinge Number	
	2" Track	3" Track
Intermediate VII	#9	#11
Intermediate VI	#8	#10
Intermediate V	#7	#9
Intermediate IV	#6	#8
Intermediate III	#5	#7
Intermediate II	#4	#6

Graduated End Hinge Schedule

Section Type	Graduated End hinge Number	
	2" Track	3" Track
Intermediate I	#3	#5
Lock	#2	#4
Bottom	#1	#3

See Figure 21 and Figure 22 for the following steps.

If You Have Single End Stiles:

- 5a. Using sawhorses, lay the bottom section 1 on a flat smooth surface.
- 5b. Locate (2) #1/#3 graduated end hinges 2 for the end stiles 3.
- 5c. Starting on the left hand side of the bottom section, align the lower hinge leaves 4 of the #1/#3 graduated end hinge over the two punch marks, located at the top of the single end stile 5.
- 5d. Attach the lower hinge leaves to the section using (2) 1/4" - 14 x 7/8" self drilling screws 6.
- 5e. Repeat the same process for the right hand side.
- 5f. Place a short stem track roller 7 into each graduated end hinges.

If You Have Double End Stiles:

- 5a. Using sawhorses, lay the bottom section 1 on a flat smooth surface.
- 5b. Locate (4) #1/#3 graduated end hinges 2 for the end stiles 3.
- 5c. Starting on the left hand side of the bottom section, align two of the lower hinge leaves 4 of the #1/#3 graduated end hinge over the two punch marks, located at the top of the double end stile 8.
- 5d. Attach the lower hinge leaves to the section using (4) 1/4" - 14 x 7/8" self drilling screws 6.
- 5e. Repeat the same process for the right hand side.
- 5f. Place a long stem track roller 9 into each graduated end hinges.

To Install Center Hinges On Sections With No Fins:

- 5g. Position the center hinge 10 over the center stile 11.
- 5h. Using the center line of the center stile as a guide, secure the center hinge to the section using (2) 1/4" - 14 x 7/8" self drilling screws.
- 5i. Repeat the same process for other center hinge(s).
- 5j. Repeat graduated end hinge and center hinge attachment using the appropriate graduated end hinges for all remaining sections, except for the top section.

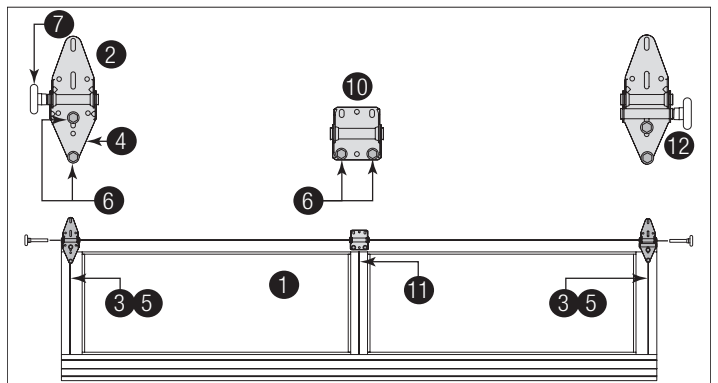

Figure 21

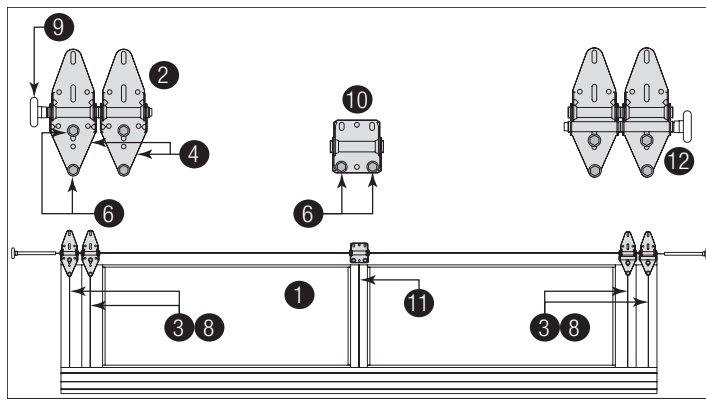

Figure 22

1	Bottom Section	7	Short Stem Track Roller
2	Graduated End Hinges	8	Double End Stile
3	End Stiles	9	Long Stem Track Roller
4	Lower Hinge Leafs	10	Center Hinge
5	Single End Stile	11	Center Stile
6	1/4" - 14 x 7/8" Self Drilling Screws	12	Hinge Tube

6 ATTACHING TOP FIXTURES TO TOP SECTION

NOTE: Refer to Door Section Identification / Breakdown of Parts.

NOTE: If your door came with two top fixtures, then one top fixture and a short stem track roller are required for each side.

NOTE: If your door came with four top fixtures, then two top fixtures and a long stem track roller are required for each side.

NOTE: The top fixture slide will be tightened and adjusted later, in step, Adjusting Top Fixture.

IMPORTANT: Ensure the top fixture slide is able to slide along the top fixture base. If needed, loosen the 5/16" - 18 hex nut.

See Figure 23 and Figure 24 for the following steps.

6a. Loosely secure the top fixture slide (1) and the "L" reinforcement bracket (2) (if applicable) to the top fixture base (3) using one 5/16" - 18 x 3/4" carriage bolt (4) and one 5/16" - 18 hex nut (5).

6b. Repeat for other top fixture assembly(s).

6c. Using sawhorses, lay the top section (6) on a flat smooth surface.

6d. Starting on the left hand side of the top section, align the lip (7) of the top fixture base on top of the corner of the top section and even with the edge of the section.

6e. Fasten to the top section using (4) 1/4" - 14 x 7/8" self drilling screws (8).

6f. Fasten the "L" reinforcement bracket (if applicable) to the section using (1) 1/4" - 14 x 7/8" self drilling screw.

6g. Repeat the same process for other top fixture assembly(s).

6h. Insert the appropriate short (9) / long stem track roller (10) into the top fixture slide(s).

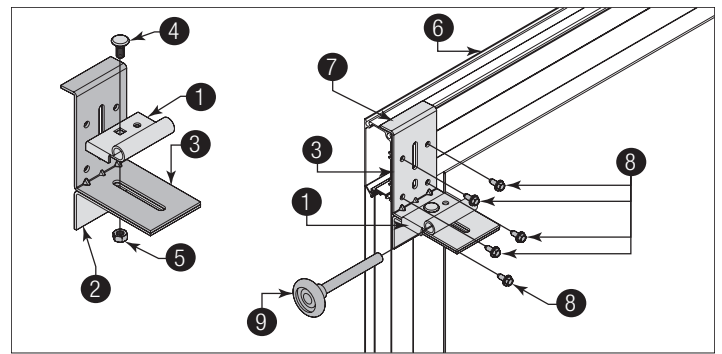

Figure 23, Left Side Shown

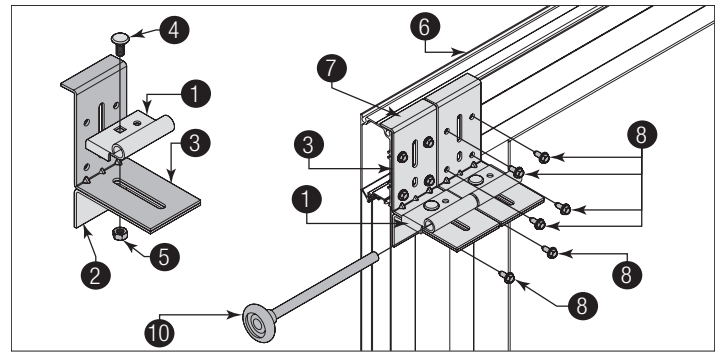

Figure 24, Left Side Shown

1	Top Fixture Slide	6	Top Section
2	"L" Reinforcement Bracket	7	Lip
3	Top Fixture Base	8	1/4" - 14 x 7/8" Self Drilling Screws
4	5/16" - 18 x 3/4" Carriage Bolt	9	Short Stem Track Roller
5	5/16" - 18 Hex Nut	10	Long Stem Track Roller

NOTE: Refer to your Windload Specification Sheet to determine if a strut is required to be installed along the top rail of the top section.

See Figure 25 and Figure 26 for the following steps.

6i. Refer to the Windload Specification Sheet for the required number of 1/4" - 14 x 7/8" self drilling screws to be used to secure the strut (11) to the top rail (12) of the top section.

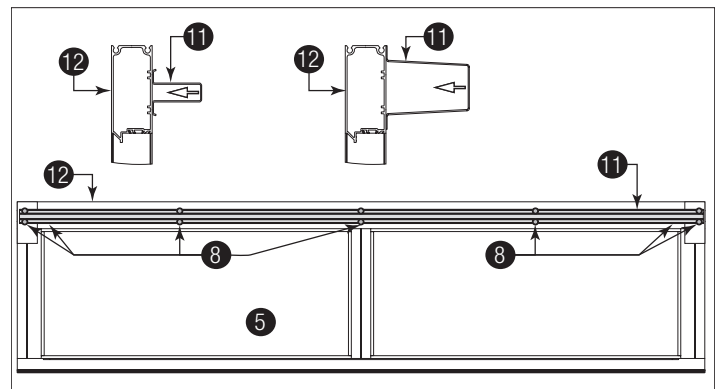

Figure 25

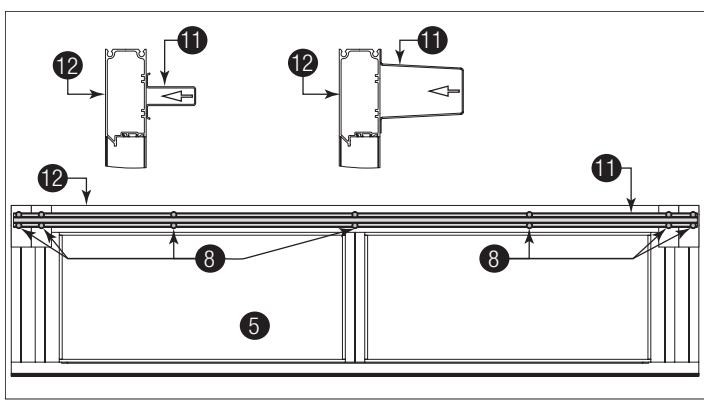

Figure 26

11	Strut	12	Top Rail
----	-------	----	----------

7 PRE-ANGLE ATTACHMENT

NOTE: Refer to your Windload Specification Sheet to determine if a single or double angle is required to be installed along the lower rail of section 1.

NOTE: The single or double angles 2 will have pre-punched holes 3. The aluminum fins 4 will not.

CAUTION

BE CAREFUL TO KEEP DRILL STRAIGHT WHEN PRE-DRILLING. SECTION DAMAGE CAN RESULT FROM FAILURE TO KEEPING THE DRILL STRAIGHT.

See Figure 27 and Figure 28 for the following steps.

- 7a. Using the appropriate section, position the long leg 5 of the angle on top of the fin.
- 7b. Center the angle from side to side on the fin surface.
- 7c. Temporarily clamp the angle to the fin to hold it in place.
- 7d. Using the angle as a template, mark the hole locations onto the fin.
- 7e. Remove the angle from the fin. Drill through the fin at each marked hole location using a 5/16" drill bit 6.

IMPORTANT: Remove all burrs from the drilled holes before proceeding to next step.

- 7f. Repeat the same process for other sections.

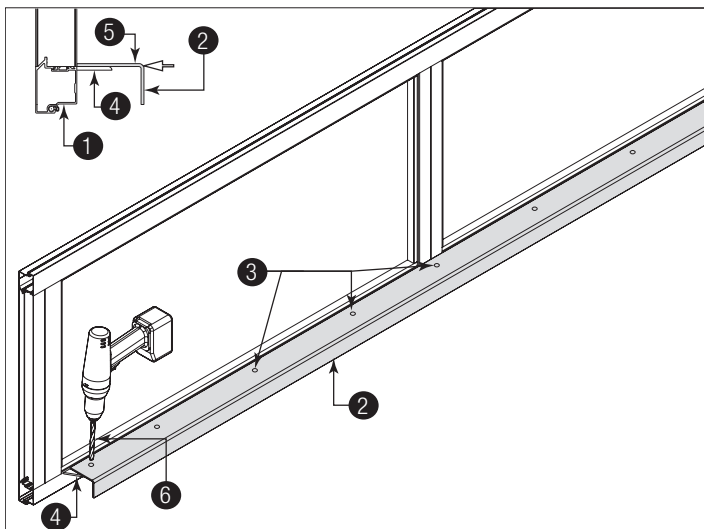

Figure 27

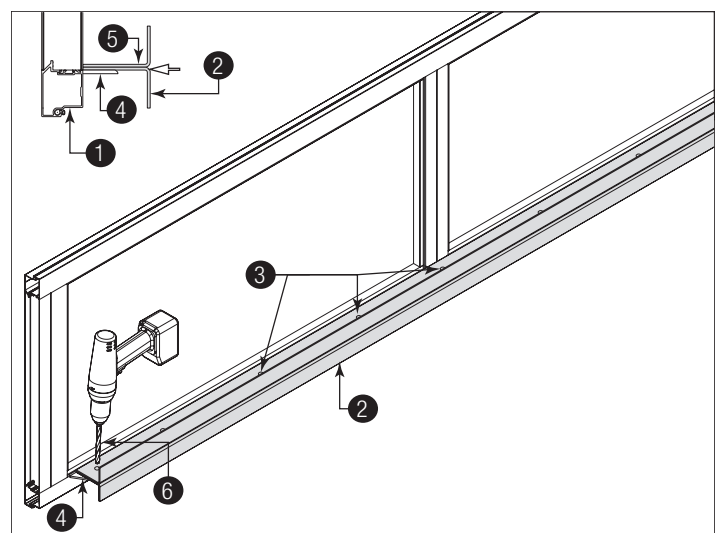

Figure 28

1	Lower Rail Of Section	4	Aluminum Fins
2	Single Or Double Angle	5	Long Leg
3	Pre-Punched Holes	6	5/16" Drill Bit

8 POSITIONING BOTTOM SECTION

See Figure 29 for the following steps.

- 8a. Center the bottom section 1 in the door opening.
- 8b. Use a level 2 and wood shims 3 (if necessary) to level the bottom section. When the bottom section is leveled, temporarily hold it in place by driving a nail into the jamb and bending it over the edge of the bottom section on both sides.

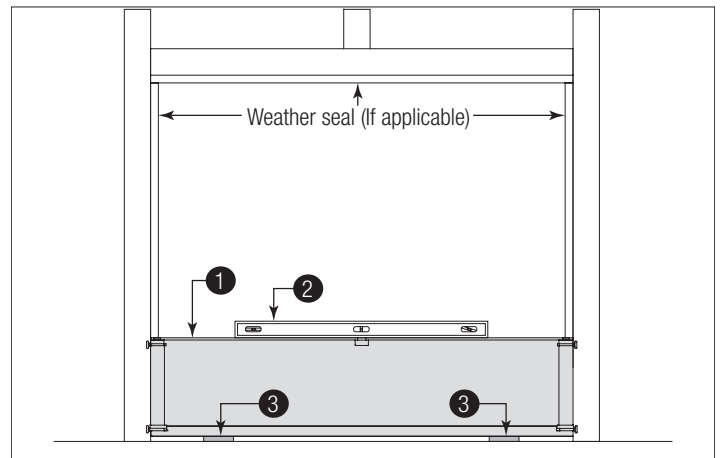

Figure 29

1	Bottom Section	3	Wood Shims
2	Level		

9 ATTACHING WALL ANGLE SEALS

NOTE: If you don't have wall angle seals, then skip this step. Refer to Package Contents and or illustrations below, to determine which wall angle seals you have received.

See Figure 30 for the following steps.

9a. Starting with the left hand wall angle, align the profile of the wall angle seal ① with the inside edge of wall angle ②.

9b. Slide wall angle seal over the inside edge of wall angle until seal is flush up against the edge of wall angle.

9c. Repeat the same process for the right hand side wall angle.

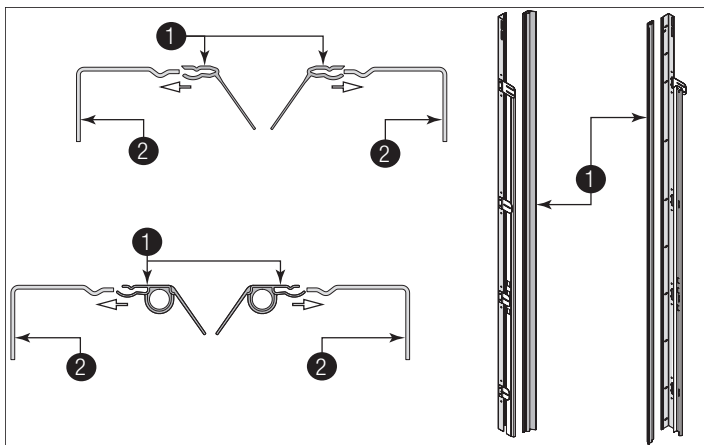

Figure 30

1	Wall Angle Seal	2	Wall Angle
---	-----------------	---	------------

10 ATTACHING VERTICAL TRACKS TO JAMBS

IMPORTANT: Depending on your door, you may have Fully Adjustable Flag Angles, Riveted Vertical Track Assemblies or you may have Angle Mount Vertical Track Assemblies. Refer to Package Contents / Breakdown of Parts, to determine which Flag Angles / Vertical Track Assemblies you have.

IMPORTANT: If this door is to be installed prior to a finishing construction of the building's floor, the vertical tracks and the door bottom section assembly should be installed such that when the floor is constructed, no door or track parts are trapped in the floor construction.

IMPORTANT: If the bottom section was leveled with shims, the vertical track on the shimmed side must be raised the same height as the shim. Recheck the top of the vertical tracks to be level from side to side.

IMPORTANT: Make sure the counterbalance lift cable is located between the track rollers and the door jamb.

See Figure 31 through Figure 33 for the following steps.

10a. Starting on the left hand side of the bottom section ①, remove the nail. Position the left hand vertical track assembly ② over the track rollers of the bottom section and install, as shown. Drill 3/16" pilot holes into the door jamb for the lag screws.

IMPORTANT: For proper flag angle lag screw location, note the flag angle styles ③.

For Doors With Fully Adjustable Flag Angles:

10b. Loosely fasten jamb brackets ④ and flag angle ⑤ to the jamb using 5/16" x 1-5/8" lag screws ⑥.

10c. Tighten lag screws, securing the bottom jamb bracket to jamb, maintain 3/8" to 5/8" spacing for 2" Track or 1/2" to 3/4" spacing for 3" Track ⑦, between the bottom section and vertical track.

10d. Hang counterbalance lift cable over flag angle. Repeat same process for other side.

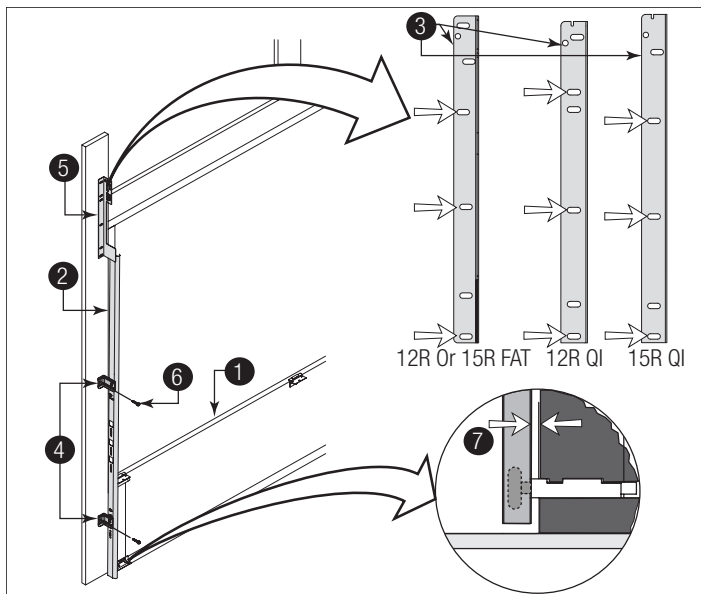

Figure 31, Left Side Shown

For Doors With Riveted Vertical Track Assemblies:

10b. Loosely fasten jamb brackets ④ and flag angle ⑤ to the jamb using 5/16" x 1-5/8" lag screws ⑥.

10c. Tighten lag screws, securing the bottom jamb bracket to jamb, maintain 3/8" to 5/8" spacing for 2" Track or 1/2" to 3/4" spacing for 3" Track ⑦, between the bottom section and vertical track.

10d. Hang counterbalance lift cable over flag angle. Repeat same process for other side.

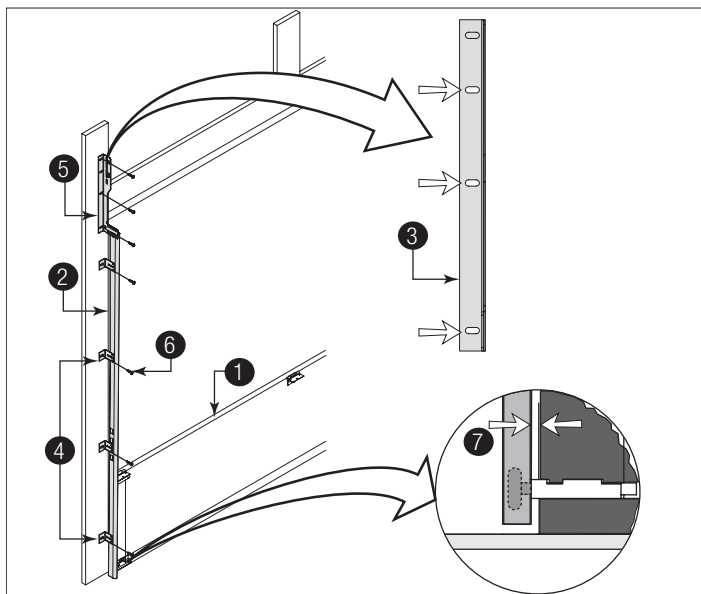

Figure 32, Left Side Shown

1	Bottom Section	5	Flag Angle
2	Vertical Track Assembly	6	5/16" x 1-5/8" Lag Screws
3	Flag Angle Styles	7	3/8" to 5/8" (For 2" Track) / 1/2" to 3/4" (For 3" Track) Spacing
4	Jamb Brackets		

For Doors With Angle Mount Vertical Track Assemblies:

IMPORTANT: Prior to installing your angle mount vertical track assemblies, measure the radius of your horizontal tracks. If you have 12" Radius horizontal tracks, locate the top portion of the angle mounts 8 and cut off 3" 9 from the top of each angle mount.

10b. Loosely fasten the slots 10 in the angle mount 11 to the jamb using 5/16" x 1-5/8" lag screws 6.

10c. Tighten lag screws, securing the bottom slot 12 in the angle mount, maintain 3/8" to 5/8" spacing for 2" Track or 1/2" to 3/4" spacing for 3" Track 7, between the bottom section and vertical track.

10d. Hang counterbalance lift cable over angle mount. Repeat same process for other side.

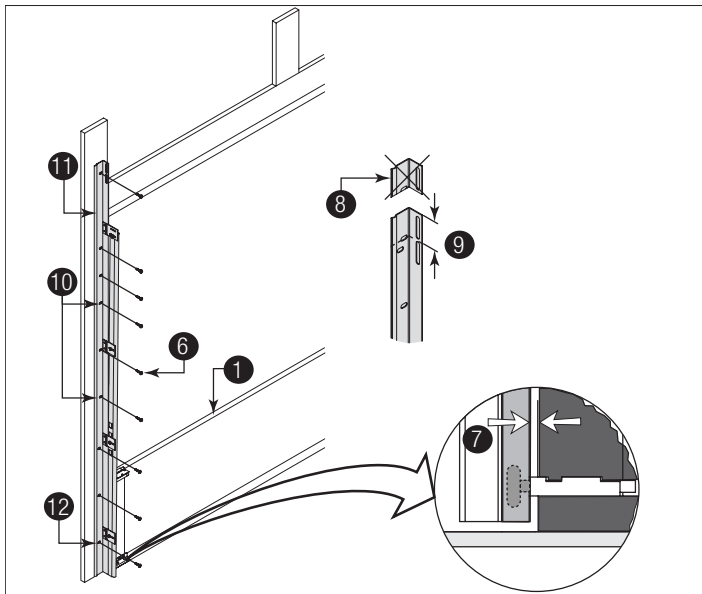

Figure 33, Left Side Shown

1	Bottom Section	9	3"
6	5/16" x 1-5/8" Lag Screws	10	Slots
7	3/8" to 5/8" (For 2" Track) / 1/2" to 3/4" (For 3" Track) Spacing	11	Angle Mount
8	Top Portion Of Angle Mount	12	Bottom Slot

NOTICE

BEFORE STACKING SECTIONS, MAKE SURE GRADUATED END AND CENTER HINGES ARE FLIPPED DOWN 1 TO AVOID POSSIBLE DAMAGE TO YOUR DOOR, WHEN STACKING ANOTHER SECTION ON TOP.

See Figure 34 and Figure 35 for the following steps.

11a. Install track rollers into graduated end hinges of remaining sections.

11b. With a helper, lift second section 2, and guide the track rollers into the vertical tracks 3. Lower section until it is seated against bottom section.

11c. Flip hinges up 4. Fasten center hinge(s) 9 first; then graduated end hinges 5 6 7 8 last using 1/4" - 14 x 7/8" self drilling screws 10.

11d. Repeat same process for other sections, except top section.

IMPORTANT: Push & hold the hinge leafs securely against the sections while securing with fasteners to it. There should be no gap between the hinge leaves and the sections.

IMPORTANT: When placing the track rollers into the #2 graduated end hinges and higher, the track roller goes into the hinge tube furthest away from the section.

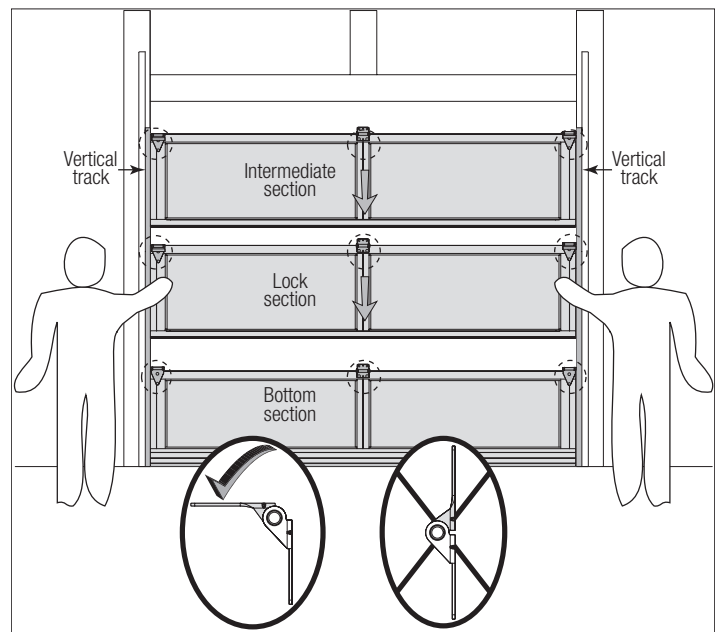

Figure 34

1	Hinge Flipped Down Position	3	Vertical Tracks
2	Second Section		

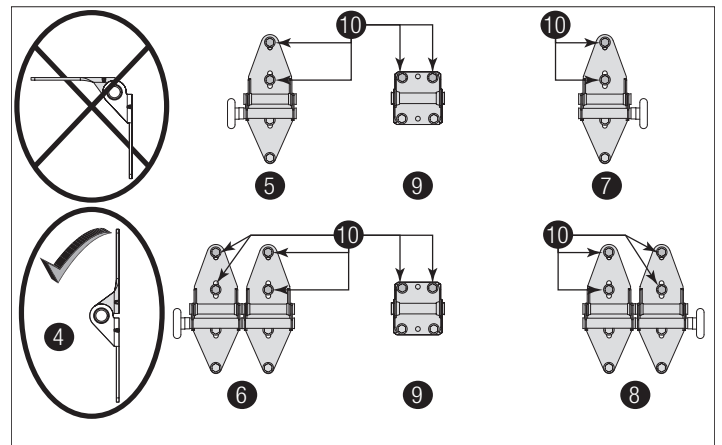

Figure 35

11 STACKING SECTIONS

NOTE: Refer to door section identification, located in the pre-installation section of this manual or refer to Breakdown of Parts.

4	Hinge Flipped Up Position	8	Right Graduated End Hinges with Long Stem Track Roller
5	Left Graduated End Hinge with Short Stem Track Roller	9	Center Hinge(s)
6	Left Graduated End Hinges with Long Stem Track Roller	10	1/4" - 14 x 7/8" Self Drilling Screw Locations
7	Right Graduated End Hinge with Short Stem Track Roller		

IMPORTANT: The distance between the pull handle(s) and the middle of the lift handle(s) must be 20" minimum to 30" maximum. If necessary, reposition the upper lift handle(s) to stay within the required dimension.

IMPORTANT: The lift handle(s) and the pull handle(s) need to be vertically aligned.

CAUTION

BE CAREFUL TO KEEP DRILL STRAIGHT WHEN PRE-DRILLING. SECTION DAMAGE CAN RESULT FROM FAILURE TO KEEPING THE DRILL STRAIGHT.

WARNING

TO AVOID POSSIBLE INJURY, LIFT HANDLE(S) THAT ARE INSTALLED WITHIN 4 INCHES (102MM) OF A SECTION INTERFACE SHALL PROMOTE VERTICAL ORIENTATION OF THE HAND.

See Figure 37 for the following steps.

13a. On the inside of the lock (second) section ①, locate the vertical center stile ②. Position and center the lift handle ③ on the lock (second) section.

13b. Using the holes in the lift handle as a template, mark the hole locations onto the section surface. Drill 9/32" diameter holes straight through the entire section at each marked location.

13c. Assemble the lift handle to the lock (second) section using two 1/4" - 20 x 5/8" self drilling screws ④.

13d. Using the pre-drilled holes, assemble the lift handle to the outside of bottom section using two 1/4" - 20 x 5/8" self drilling screws ④.

13e. If applicable, repeat the same process for other lift handles.

12 ATTACHING PULL HANDLES TO SECTION

IMPORTANT: The pull handle(s) needs to be horizontally aligned with the bottom section rail.

CAUTION

BE CAREFUL TO KEEP DRILL STRAIGHT WHEN PRE-DRILLING. SECTION DAMAGE CAN RESULT FROM FAILURE TO KEEPING THE DRILL STRAIGHT.

See Figure 36 for the following steps.

12a. On the inside of bottom section ①, locate the bottom horizontal rail ②. Using the illustrations below, position and center the pull handle ③ on the bottom section, as shown.

12b. Using the holes in the pull handle as a template, mark the hole locations onto the section surface. Drill 9/32" diameter holes straight through the entire section at each marked location.

12c. Assemble the pull handle to the inside of bottom section using two 1/4" - 20 x 5/8" self drilling screws ④.

12d. Using the pre-drilled holes, assemble the pull handle to the outside of bottom section using two 1/4" - 20 x 5/8" self drilling screws ④.

12e. If applicable, repeat the same process for other pull handles.

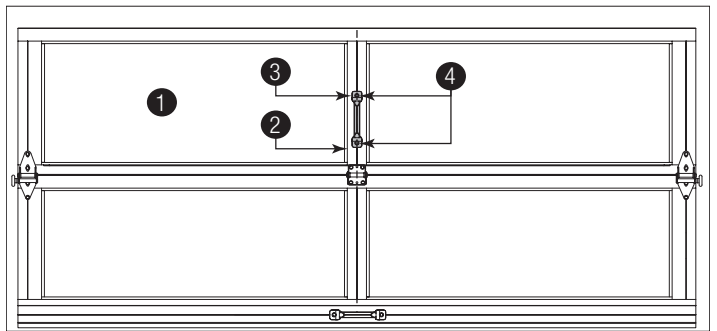

Figure 37

1	Inside Of The Lock (Second) Section	3	Lift Handle
2	Vertical Center Stile	4	1/4" - 20 x 5/8" Self Drilling Screws

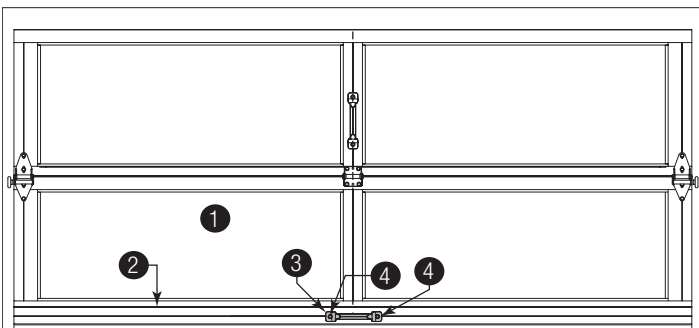

Figure 36

1	Bottom Section	3	Pull Handle
2	Bottom Horizontal Rail	4	1/4" - 20 x 5/8" Self Drilling Screws

13 LIFT HANDLES

14 STACKING TOP SECTION

IMPORTANT: The dimension between the flag angles or angle mounts ① must be door width plus 3-3/8" (86mm) to 3-1/2" (89 mm) for 2" track applications or door width plus 4-7/8" (124mm) to 5" (127 mm) for 3" track applications for smooth, safe door operation.

See Figure 38 for the following steps.

14a. Place the top section ② in the opening, on top of the section stacked.

14b. Install a nail ③ to temporarily hold the top section.

14c. Flip up the hinge leaves, hold tight against section, and fasten center hinges first and end hinges last (see Stacking Sections).

14d. Position flag angle or angle mount ④ between 1-11/16" to 1-3/4" for 2" track applications or 2-3/16" to 2-1/4" for 3" track applications from the edge of the door ⑤, then tighten the bottom lag screw. Flag angles or angle mount must be parallel to the door sections. Repeat for other side.

14e. Complete the vertical track ⑥ installation.

If you have fully adjustable track or riveted track: Secure the jamb bracket(s) and tightening the other lag screws. Push the vertical track against the track rollers so that the track rollers are touching the deepest part of the curved side of the track; tighten all the track bolts and nuts. Repeat for other side.

If you have Angle Mount Track: Complete the vertical track installation by tightening the other lag screws. Push the vertical track against the track rollers so that the track rollers are touching the deepest part of the curved side of the vertical track. Repeat for other side.

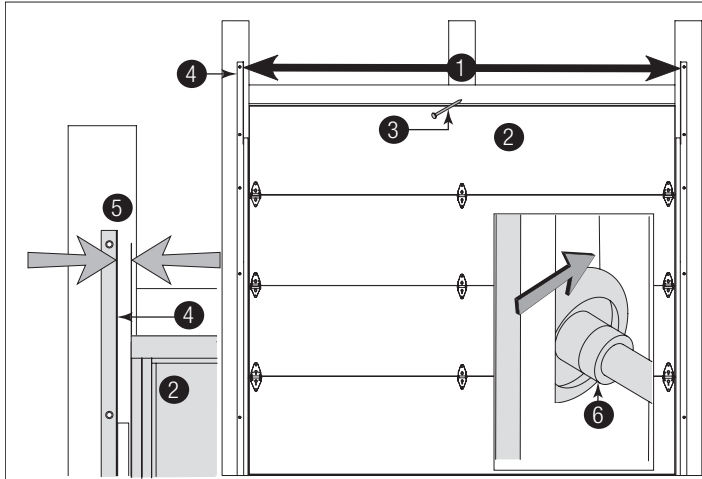

Figure 38

1	Clearance Measurement Between Both Flag Angles	4	Flag Angle Or Angle Mount
2	Top Section	5	Clearance Measurement Between Flag Angle and Door Edge
3	Nail	6	Vertical Track Against Track Rollers

15 ATTACHING HORIZONTAL TRACKS

NOTE: Depending on your door, you may have Fully Adjustable Flag Angles, Riveted Vertical Track Assemblies or you may have Angle Mount Vertical Track Assemblies. Refer to Package Contents / Breakdown of Parts, to determine which Flag Angles / Vertical Track Assemblies you have.

⚠ WARNING

DO NOT RAISE DOOR UNTIL HORIZONTAL TRACKS ARE SECURED AT REAR, AS OUTLINED IN STEP 24, ATTACHING REAR BACK HANGS. THE REAR BACK HANGS OR DOOR COULD FALL FROM OVERHEAD POSITION CAUSING DEATH OR SERIOUS INJURY.

For Flag Angles:

See Figure 39 for the following steps.

15a. Place the curved end of the horizontal track ① over the top track roller of the top section.

15b. Attach the horizontal track to the flag angle ② with two 1/4" - 20 x 9/16" track bolts ③ and two 1/4" - 20 flange hex nuts ④.

15c. Level ⑦ the horizontal track assembly and bolt the horizontal track angle ⑧ to the first encountered slot in the flag angle using one 3/8" - 16 x 3/4" truss-head bolt ⑤ and one 3/8" - 16 hex nut ⑥. Repeat for right side.

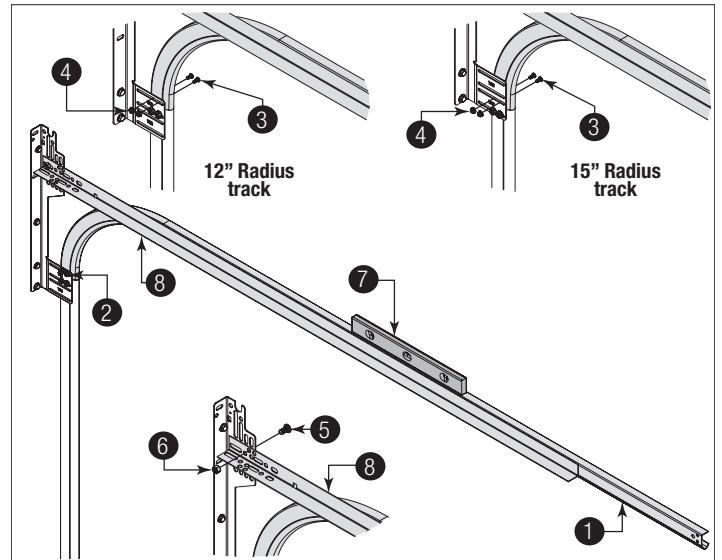

Figure 39, Left Side Shown

1	Horizontal Track	5	3/8" - 16 x 3/4" Truss-Head Bolt
2	Flag Angle Upper Slot	6	3/8" - 16 Hex Nut
3	1/4" - 20 x 9/16" Track Bolts	7	Level
4	1/4" - 20 Flange Hex Nuts	8	Horizontal Track Angle

If you have Angle Mount Track:

See Figure 40 for the following steps.

15a. Place the curved end of the horizontal track ① over the top track roller of the top section.

15b. Attach the horizontal track to the angle mount ② with two 1/4" - 20 x 9/16" track bolts ③ and two 1/4" - 20 flange hex nuts ④.

15c. Level ⑦ the horizontal track assembly and bolt the horizontal track angle ⑧ to the first encountered slot in the angle mount using one 3/8" - 16 x 3/4" truss-head bolt ⑤ and one 3/8" - 16 hex nut ⑥. Repeat for right side.

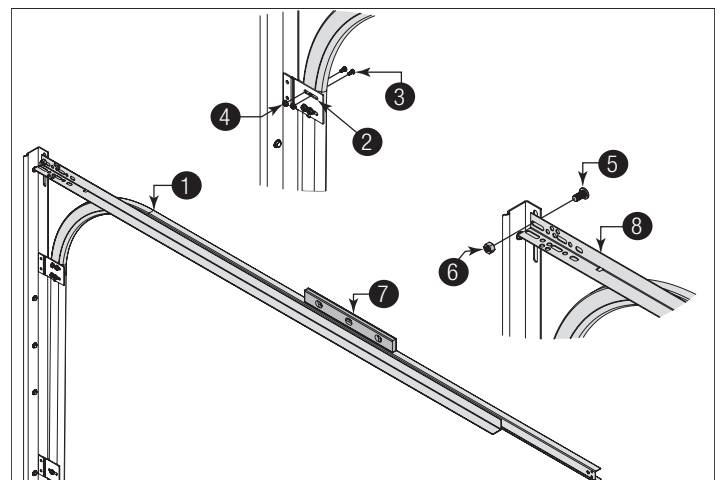

Figure 40, Left Side Shown

1	Horizontal Track	5	3/8" - 16 x 3/4" Truss-Head Bolt
2	Angle Mount	6	3/8" - 16 Hex Nut
3	1/4" - 20 x 9/16" Track Bolts	7	Level
4	1/4" - 20 Flange Hex Nuts	8	Horizontal Track Angle

15d. When complete, remove the nail that was holding the top section in position.

NOTICE

FAILURE TO REMOVE NAIL BEFORE ATTEMPTING TO RAISE DOOR COULD CAUSE PERMANENT DAMAGE TO TOP SECTION.

16 ADJUSTING TOP FIXTURES

See Figure 41 for the following steps.

16a. Vertically align the top section ① of the door with the lower sections. Position the top fixture slide ② with a track roller ⑤ out against the horizontal track ⑥.

16b. Maintaining the slide's position, tighten the 5/16" - 18 hex nut ③ to secure the top fixture slide to the top fixture base ④.

16c. Repeat for right side.

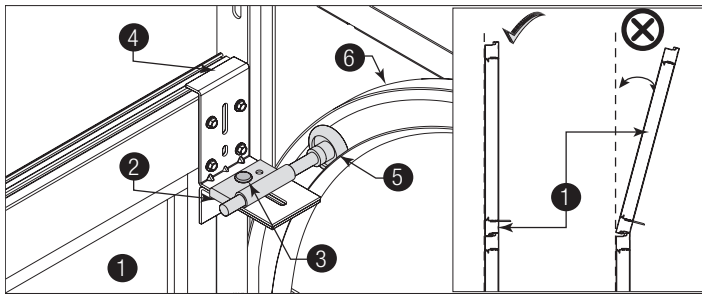

See Figure 41, Left Side Shown

1	Door Top Section	4	Top Fixture Base
2	Top Fixture Slide	5	Track Roller
3	5/16" - 18 hex Nut	6	Horizontal Track

17 ANGLE ATTACHMENT

See Figure 42 and Figure 43 for the following steps.

17a. Refer to step Pre-Angle Attachment and reposition the angle ① back onto the fin ② of the section ③. Center the angle from side to side on the fin surface.

17b. Ensure the holes in the fin and the holes in the angle line up ④ with each other.

17c. Secure the angle to the fin using one 5/16" - 18 x 1" hex head bolt ⑤ and one 5/16" - 18 hex nut ⑥ at each hole location.

17d. Repeat the same process for other sections.

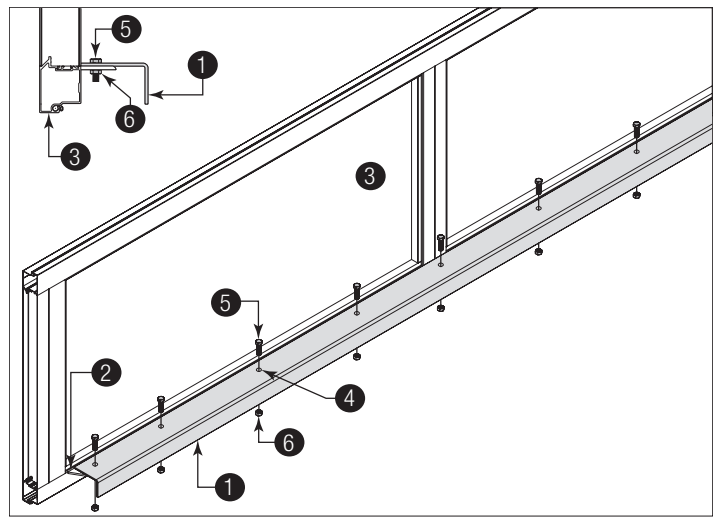

See Figure 42

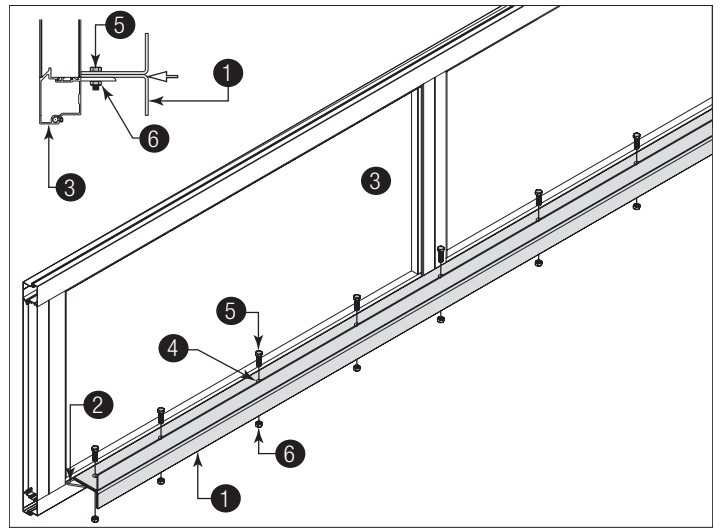

See Figure 43

1	Angle	4	Holes Line Up
2	Fin	5	5/16" - 18 x 1" Hex Head Bolt
3	Section	6	5/16" - 18 Hex Nut

COUNTERBALANCE INSTALLATION INSTRUCTIONS

18 ATTACHING END BEARING BRACKETS

NOTE: Refer to Package Contents or Breakdown Of Parts, to determine which type of end bearing bracket **1** you received.

IMPORTANT: Measure the radius of your horizontal track to determine if your horizontal track **3** is 12" or 15" Radius. The end bearing bracket's lower slots **4** are used on doors with 12" radius track, the upper slots **5** are used on doors with 15" radius track.

IMPORTANT: Drill 3/16" pilot holes into the door jamb for the lag screws.

NOTE: End bearing brackets are right and left hand.

See Figure 44 through Figure 46 for the following steps.

18a. Attach the left hand end bearing bracket to the left flag angle **2** (For N3. Bracket) or through the end bearing bracket's upper / lower slots to the left hand horizontal track angle **6** (For N4. Bracket) using two 3/8" - 16 x 3/4" truss head bolts **7** and two 3/8" - 16 hex nuts **8**.

18b. Secure the top of the end bearing bracket to the jamb **9** using 5/16" x 1-5/8" lag screw(s) **10**.

18c. Repeat the same process for right hand side.

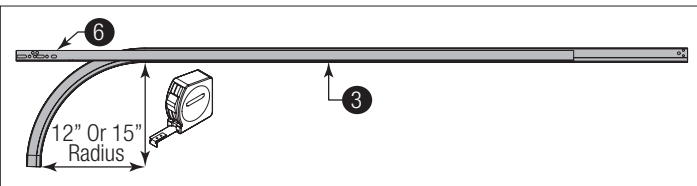

Figure 44

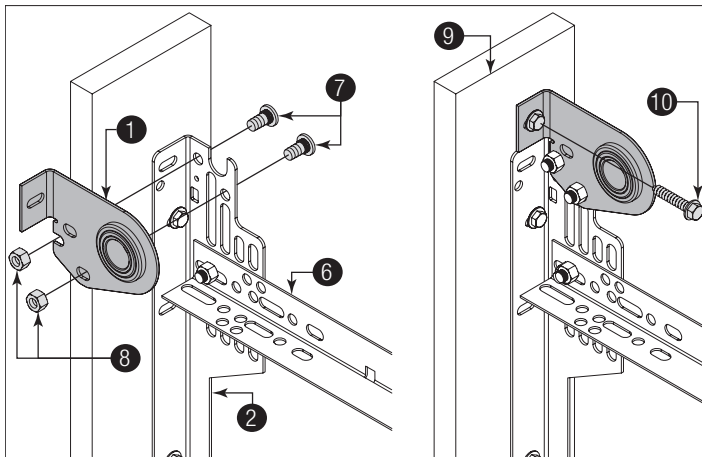

Figure 45, Left Side Shown (For L3. Bracket)

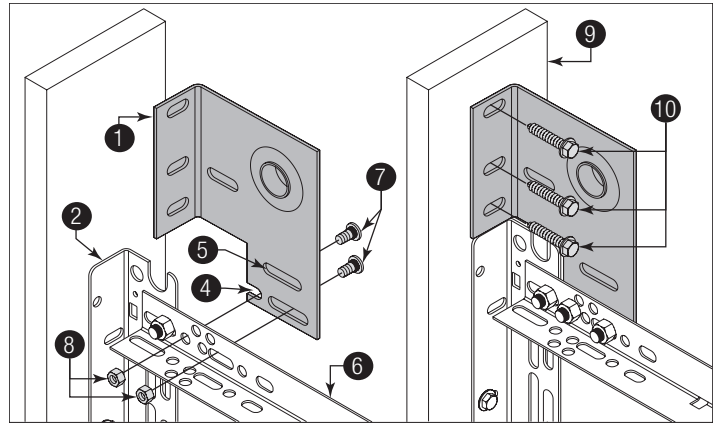

Figure 46, Left Side Shown (For L4. Bracket)

1	End Bearing Bracket	6	Horizontal Track Angle
2	Flag Angle	7	3/8" - 16 x 3/4" Truss Head Bolts
3	Horizontal Track	8	3/8" - 16 Hex Nuts
4	Lower Slots	9	Jamb
5	Upper Slots	10	5/16" x 1-5/8" Lag Screw(s)

19 ATTACHING CENTER BRACKET TO WALL

NOTE: Refer to Package Contents / Breakdown of Parts, to determine which Center Bracket(s) came with your door.

! WARNING

MAKE SURE THE CENTER BRACKET IS SECURELY INSTALLED ONTO THE HEADER. FAILURE TO DO SO, COULD RESULT IN DEATH OR SERIOUS INJURY.

IMPORTANT: Drill 3/16" pilot holes into header for the lag screws.

NOTE: Refer to Package Contents / Breakdown of Parts, to determine if your door came with a coupler assembly. If your door came with a coupler assembly, the mounting surface needs to be a minimum of 17" wide. The two center bearing brackets will need to be spaced 12" to 14" apart at the center of the door, as shown.

NOTE: If your door came with (4) springs, each of the outer springs mounting surface will need to be a minimum of 3" wide.

NOTE: If needed, measure the diameter of your springs. If you have a one piece shaft with 3-3/4" diameter springs, they do not share center brackets and do not have a coupler assembly.

See Figure 47 for the following steps.

19a. First, locate the center of the door **1**.

19b. Mark a vertical pencil line **2** on the mounting surface above the door, at the center.

19c. Measure from the center of the bearing, in one of the end bearing brackets **3**, downwards, to the top of door **4**.

19d. Using that measurement, measure that distance upwards from the top of the door to the mounting surface and mark a horizontal pencil line **5** which intersects the vertical pencil line.

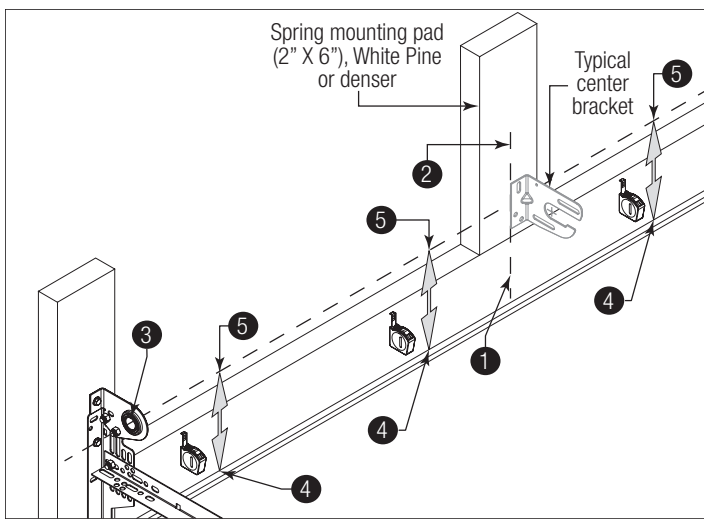

Figure 47, Left Side Shown

1	Center Of The Door	4	Top Of Door
2	Vertical Line	5	Horizontal Line
3	End Bearing Brackets		

See Figure 48 for the following steps.

If your door did not come with a center coupler assembly or Torsion Springs less than 3-3/4" ID:

19e. Mark a vertical pencil line ① on the mounting surface above the door, at the center.

19f. Align the edge of the center bracket ② with the vertical pencil line and the center of the center bracket with the horizontal pencil line ③; this is to ensure the torsion shaft is level between the center and end bearing brackets.

NOTE: On some single spring doors, the spring can be longer than half the opening width. If your spring is longer, then the center bracket must be mounted off center for the spring to fit properly. Measure spring length adding room for spring growth during winding, to determine appropriate center bracket location.

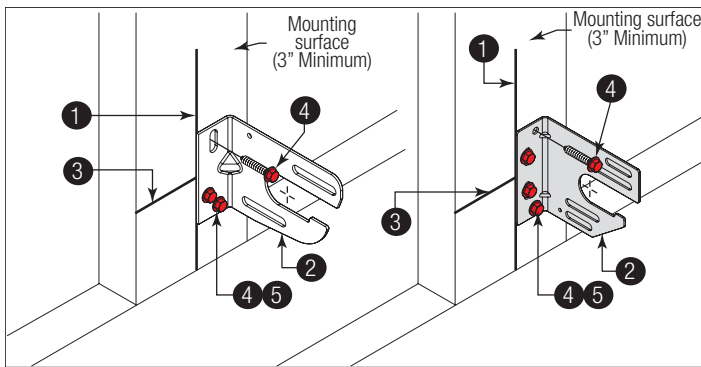

Figure 48

1	Vertical Line	3	Horizontal Line
2	Center Bracket		

See Figure 49 for the following steps.

If your door did come with a center coupler assembly or 3-3/4" ID Torsion Springs:

19e. Mark a vertical pencil line ① on the mounting surface above the door, at the center.

19f. Split the difference up and position the (2) center bearing brackets ② apart from each other.

19g. Mark two vertical pencil lines, one for each center bearing bracket onto the mounting surface above the door.

NOTE: If your door came with a center coupler assembly or if it utilizes 3-3/4" springs, the springs will not share a center bracket.

NOTE: If your door has (4) springs, split the distance between the center of the door and the end bracket on each side to locate the intermediate center brackets.

19h. Attach each of the center bracket(s) to the mounting surface, using 5/16" RED HEAD lag screws ③, as shown.

IMPORTANT: Use a 5/16" x 2-1/2" RED HEAD lag screw ④ instead of the 5/16" x 1-5/8" RED HEAD lag screw if mounting surface is covered by drywall. The lag screw must be attached through the bottom hole ⑤ of the center bracket(s). If mounting surface is a 2" x 6" board installed on top of masonry, drill a clearance hole in masonry for the 5/16" x 2-1/2" RED HEAD lag screws.

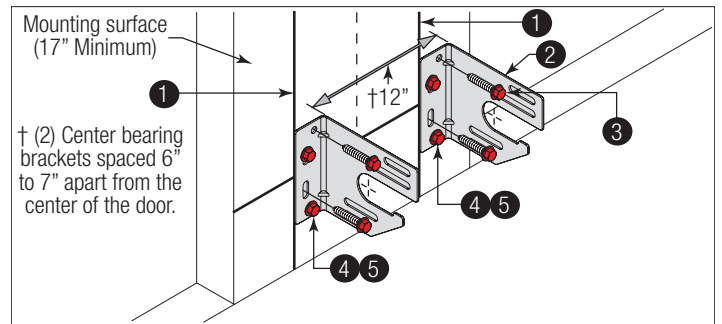

Figure 49

1	Vertical Line	4	5/16" x 2-1/2" RED HEAD lag screw
2	Center Bearing Brackets	5	Bottom Hole
3	5/16" RED HEAD Lag Screws		

20 TORSION SPRING ASSEMBLY

NOTE: Refer to the Package Contents and or Breakdown of Parts to determine if your door came with a coupler assembly.

IMPORTANT: Right and left hand is always determined from inside the building looking out.

IMPORTANT: Identify the torsion springs provided as either right wound (red winding cone) ①, which goes on the LEFT HAND SIDE or left wound (black winding cone) ②, which goes on the RIGHT HAND SIDE.

IMPORTANT: On single spring applications, only a left wound (black winding cone), is required.

NOTE: The set screws used on all winding cones and cable drums are colored red. DO NOT identify right and left hand by the set screw color.

See Figure 50 and Figure 51 for the following steps.

IF YOU DON'T HAVE A COUPLER ASSEMBLY:

20a. Facing the inside of the door, lay the torsion shaft / torsion keyed shaft ③ on the floor. Lay the torsion spring with the black winding cone and the black cable drum ④ at the right end of the torsion shaft / torsion keyed shaft. Lay the torsion spring with the red winding cone and the red cable drum ⑤ at the left end of the torsion shaft / torsion keyed shaft. Slide the center bracket bearing ⑥ onto the torsion shaft / torsion keyed shaft followed by the torsion springs and cable drums.

IMPORTANT: The center bracket bearing, torsion springs, and cable drums must be positioned, as shown.

20b. With assistance, pick up the torsion spring assembly and slide one end of the

torsion shaft / torsion keyed shaft through one end bearing bracket 7.

20c. Lay the middle of the torsion shaft / torsion keyed shaft into the center bracket 8.

20d. Slide the other end of the torsion shaft / torsion keyed shaft into the other end bearing bracket 9.

20e. Position the torsion shaft so that equal amounts 10 of the shaft extend from each end bearing bracket.

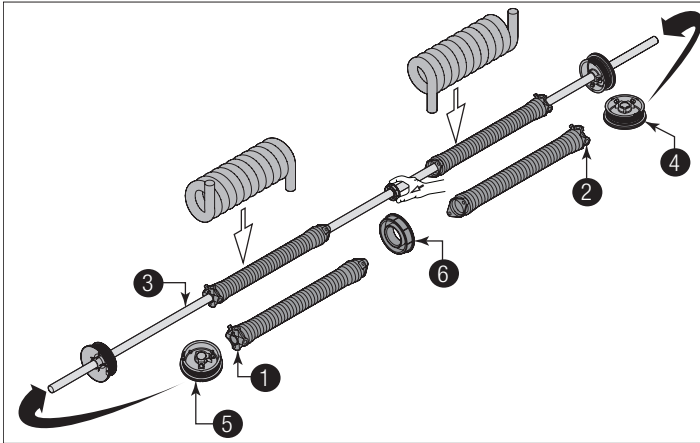

Figure 50

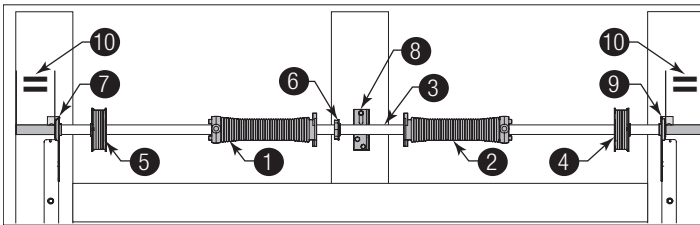

Figure 51

1	Red Winding Cone	6	Center Bracket Bearing
2	Black Winding Cone	7	End Bearing Bracket
3	Torsion Shaft / Torsion Keyed Shaft	8	Center Bracket
4	Black Cable Drum	9	End Bearing Bracket
5	Red Cable Drum	10	Equal Amounts

See Figure 52 through Figure 56 for the following steps.

IF YOU HAVE A COUPLER ASSEMBLY:

20a. Disassemble the coupler assembly 11 by removing the (3) 3/8" - 16 x 1-1/2" hex head screws 12, (6) 3/8" washers 13, (3) 3/8" lock washers 14 and the (3) 3/8" - 16 hex nuts 15 from the coupler halves 16.

20b. Loosen the set screws 17.

20c. Set the components aside.

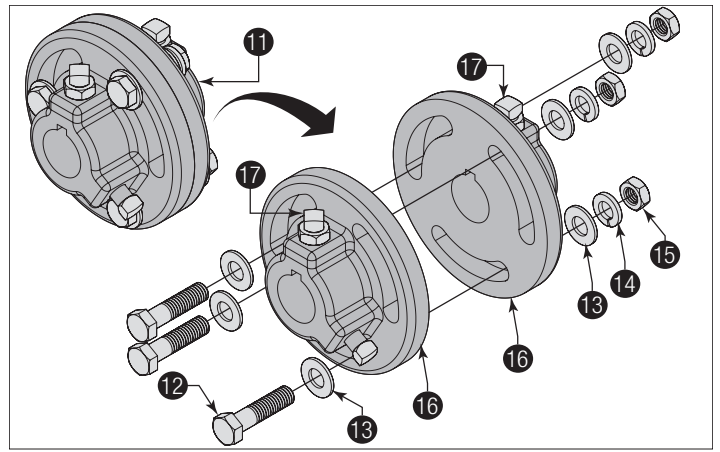

Figure 52

11	Coupler Assembly	15	3/8" - 16 Hex Nuts
12	3/8" - 16 x 1-1/2" Hex Head Screws	16	Coupler Halves
13	3/8" Washers	17	Set Screws
14	3/8" Lock Washers		

20d. Facing the inside of the door, lay the (2) torsion keyed shafts 3 on the floor. One torsion keyed shaft on the left hand side and the other torsion keyed shaft on the right hand side. Starting on the left hand side, lay one of the coupler halves, the center bracket bearing 6, torsion spring with the red winding cone 1 and the red cable drum 5 at the left end of the torsion keyed shaft. Next on the right hand side, lay the other coupler half, center bracket bearing, the torsion spring with the black winding cone 2, and the black cable drum 4 at the right end of the torsion keyed shaft. Slide the coupler halves 16, center bracket bearings onto the torsion keyed shafts followed by the torsion springs and the cable drums, as shown.

IMPORTANT: The coupler halves, center bracket bearings, torsion springs, cable drums must be positioned, as shown.

20e. Slide the flat edge of the couple half flush with the side edge of the torsion keyed shaft. Insert (1) key 18 into the slot of both the coupler half and the slot in the torsion keyed shaft. Tighten the (2) set screws 17 and the locking nut 19 to secure the coupler half to the torsion keyed shaft, as shown.

NOTE: Tighten the set screws to 14-15 ft-lbs (Once set screws contact the shaft, tighten screws an additional 1/2 turn).

20f. Repeat the same process for the other coupler half.

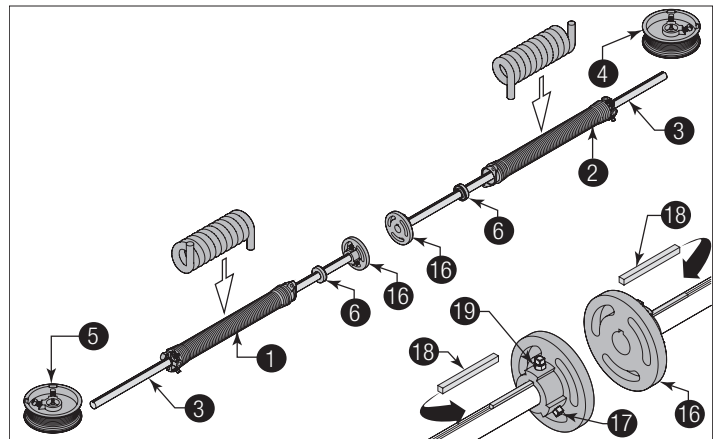

Figure 53

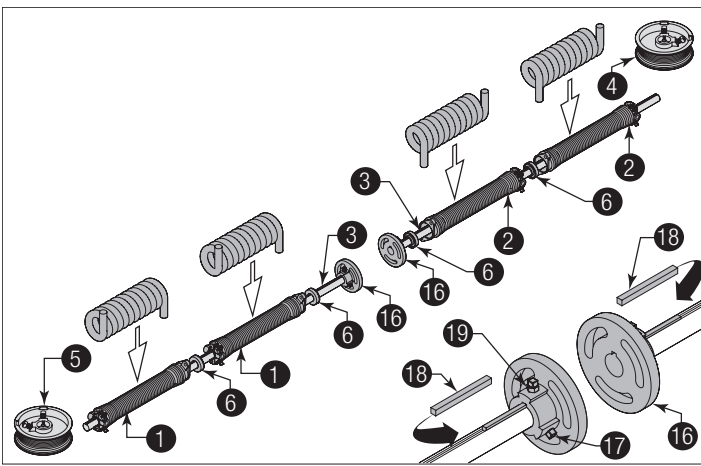

Figure 54

1	Red Winding Cone	6	Center Bracket Bearing
2	Black Winding Cone	16	Coupler Halves
3	Torsion Keyed Shafts	18	Key
4	Black Cable Drum	17	Set Screws
5	Red Cable Drum	19	Locking Nut

20g. With assistance and starting on the left hand side of door, pick up the left hand torsion spring assembly 20 and slide one end of the torsion keyed shaft through the end bearing bracket 7.

20h. Lay the other side of the torsion keyed shaft into the center bracket 8.

20i. Repeat the same process for the right hand torsion spring assembly 21.

20j. Position both torsion keyed shafts so that equal amounts 22 of the shafts extend from each end bearing brackets.

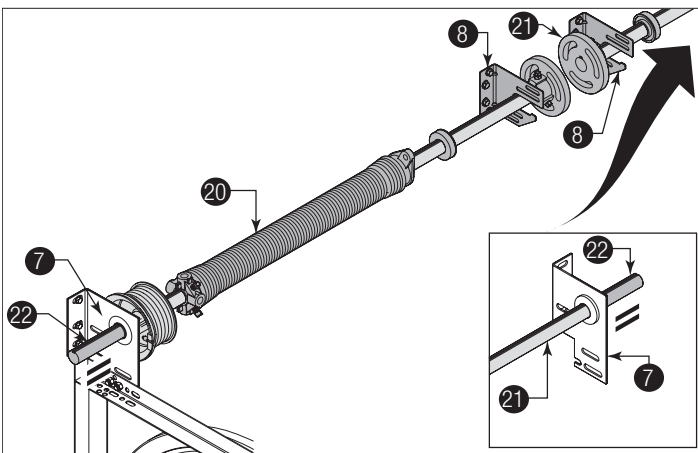

Figure 55, Left Side Shown

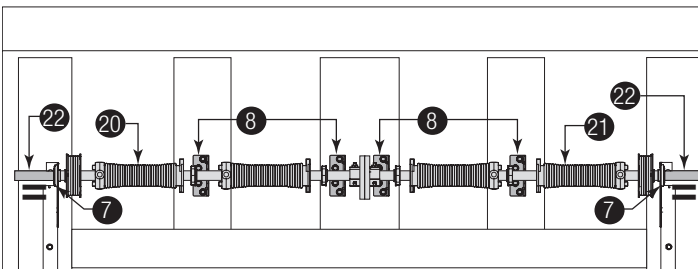

Figure 56

20	Left Hand Torsion Spring Assembly	21	Right Hand Torsion Spring Assembly
7	End Bearing Bracket	22	Equal Amounts
8	Center Bracket		

21 ATTACHING SPRINGS TO CENTER BRACKET

NOTE: Refer to Package Contents / Breakdown of Parts, to determine which Center Bracket(s) came with your door.

NOTE: Refer to Package Contents / Breakdown of Parts, to determine if your door came with a coupler assembly.

IMPORTANT: The spring warning tag(s) 1 supplied must be securely attached to the stationary spring cone(s) in plain view. Should a replacement spring warning tag be required, contact Wayne Dalton for free replacements.

NOTE: Measure the diameter of your springs. If your spring diameter is 3-3/4", the springs do not share center brackets. If your spring diameter is either 2" or 2-5/8", then two springs will share the same center bracket, unless a coupler assembly is provided.

See Figure 57 and Figure 58 for the following steps.

If you don't have a Coupler Assembly:

21a. Slide center bracket bearing 2 into the spring 3.

21b. Align the stationary spring cone(s) 4 with the holes in the center bracket 5.

21c. Secure the torsion spring(s) to the center bracket with (2) 3/8" - 16 x 1-1/2" hex head bolts 6 and (2) 3/8" - 16 nuts 7.

IMPORTANT: Never use more than one bearing when attaching two springs to one center bracket.

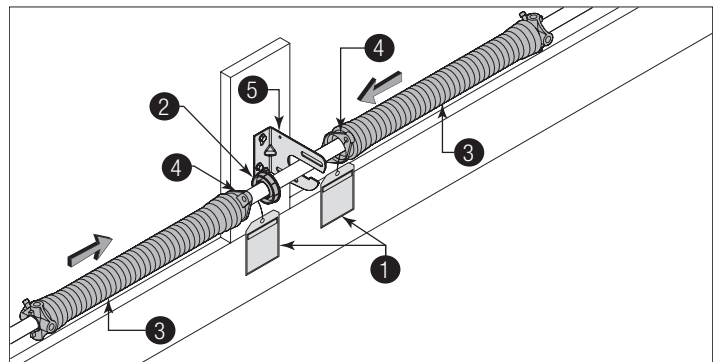

Figure 57

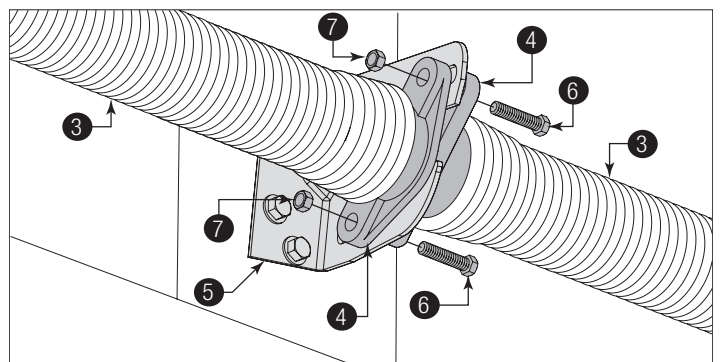

Figure 58

1	Spring Warning Tag(s)	5	Center Bracket
2	Center Bracket Bearing	6	3/8" - 16 x 1-1/2" Hex Head Bolts
3	Spring	7	3/8" - 16 Nuts
4	Stationary Spring Cone(s)		

See Figure 59 for the following steps.

If you have a Coupler Assembly:

- 21a. Slide center bracket bearing (2) into the spring (3).
- 21b. Align the stationary spring cone (4) with the holes in the center bracket (5).
- 21c. Secure the torsion spring to the center bracket with (2) 3/8" - 16 x 1-1/2" hex head bolts (6) and (2) 3/8" - 16 nuts (7).
- 21d. Repeat the same process for the other center bearing bracket.
- 21e. At the middle of the two center bearing brackets, re-assemble the coupler assembly (8) by loosely fastening the coupler halves (9) together using the (3) 3/8" - 16 x 1-1/2" hex head screws (10), (6) 3/8" washers (11), (3) 3/8" lock washers (12) and the (3) 3/8" - 16 hex nuts (13), previously removed.

NOTE: Ensure both torsion keyed shafts have equal amounts of the shafts extending from each end bearing bracket.

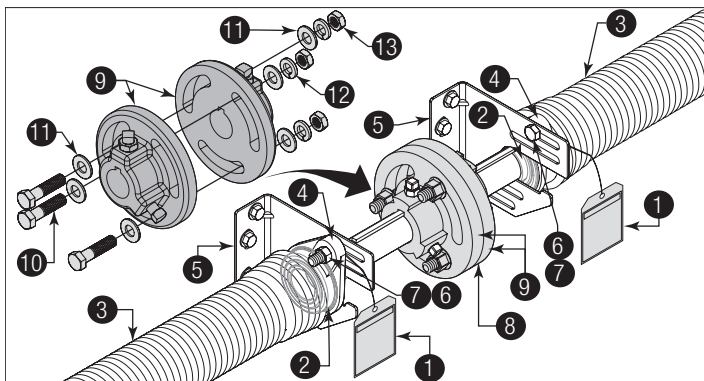

Figure 59

1	Spring Warning Tag(s)	8	Coupler Assembly
2	Center Bracket Bearing	9	Coupler Halves
3	Spring	10	3/8" - 16 x 1-1/2" Hex Head Screws
4	Stationary Spring Cone(s)	11	3/8" Washers
5	Center Bracket	12	3/8" Lock Washers
6	3/8" - 16 x 1-1/2" Hex Head Bolts	13	3/8" - 16 Hex Nuts
7	3/8" - 16 Nuts		

22 ATTACHING COUNTERBALANCE LIFT CABLES

See Figure 60 through Figure 62 for the following steps.

- 22a. Starting on the left hand side, thread the counterbalance lift cable (1) up and around the front side of the left hand cable drum (2).

IMPORTANT: Verify that there are no obstructions in the travel path of the door sections or counterbalance lift cables.

NOTE: Always assemble the left hand cable and cable drum first to help maintain equal cable tension on both sides of the door.

NOTICE

FAILURE TO REMOVE ALL SLACK OUT OF THE COUNTERBALANCE LIFT CABLES, WILL CAUSE DOOR OPERATIONAL PROBLEMS.

- 22b. Hook (3) the counterbalance lift cable into the left hand cable drum. Slide the left hand cable drum up against the left hand end bearing bracket (4). Counterbalance lift cable should terminate at the 3 o'clock position (10) - 6 o'clock position (11).

! WARNING

TO AVOID RISK OF COUNTERBALANCE FAILURE CAUSING DEATH OR SERIOUS INJURY, THE COUNTERBALANCE LIFT CABLE MUST TERMINATE BETWEEN THE 3 O'CLOCK AND 6 O'CLOCK POSITION. IF THE COUNTERBALANCE CABLE DOES NOT TERMINATE IN THE CORRECT POSITION, THE CABLE LENGTH MUST BE CORRECTED BY A TRAINED DOOR SYSTEMS TECHNICIAN BEFORE CONTINUING INSTALLATION.

NOTE: If you have torsion keyed shaft(s) (6), insert (1) key (5) into the slot of both the cable drum and the slot in the torsion keyed shaft, as shown.

- 22c. Rotate the left hand drum and torsion shaft until counterbalance lift cable is taut. Now attach locking pliers (7) to the torsion shaft (6) and brace locking pliers up against jamb (8) to keep counterbalance lift cable taut.

- 22d. Tighten the set screws (9) in the drum to 14-15 ft-lbs of torque (once set screws contact the torsion shaft, tighten screws an additional 1/2 turn for solid shaft and one full turn for tubular shaft).

- 22e. Repeat for right hand side.

IMPORTANT: Inspect each counterbalance lift cable making sure it is seated properly onto the cable drum and that both counterbalance lift cables have equal tension.

22f. Check Counterbalance Lift Cables for Equal Tension:

1. Attach locking pliers to track above top roller.
2. Grasp cable at approximate mid-door height location.
3. Draw cable toward you about 1/2" to 1" and release, noting the response of the cable.
4. Repeat above steps for other cable.
5. Adjust cable tension as needed until right and left cables both respond the same.

- 22g. Once the counterbalance cables are set and if applicable tighten the coupler assembly together by tightening the (3) 3/8" - 16 nylon hex nuts to secure the coupler halves together.

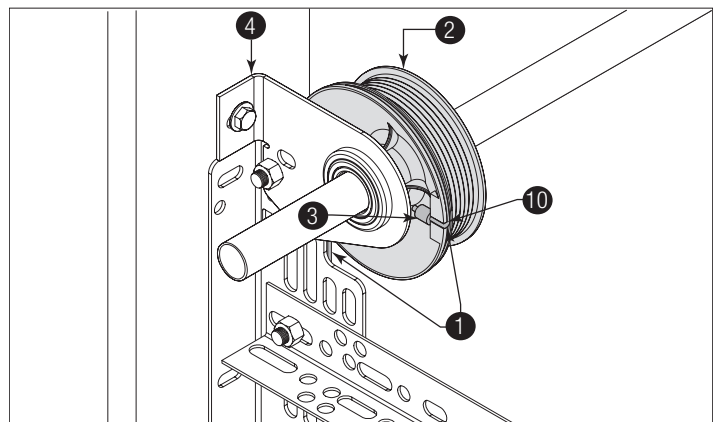

Figure 60, Left Side Shown

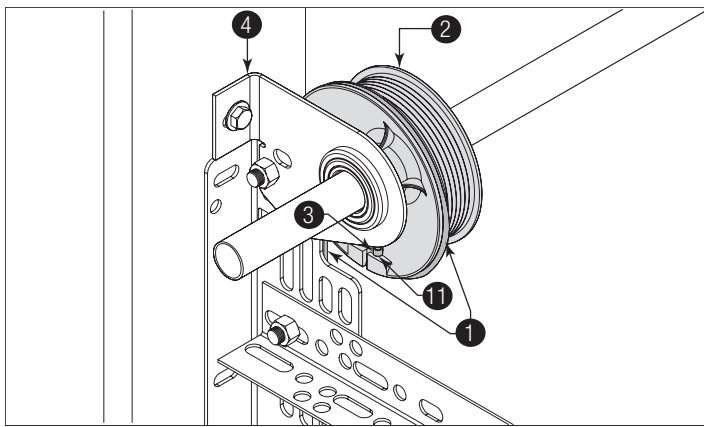

Figure 61, Left Side Shown

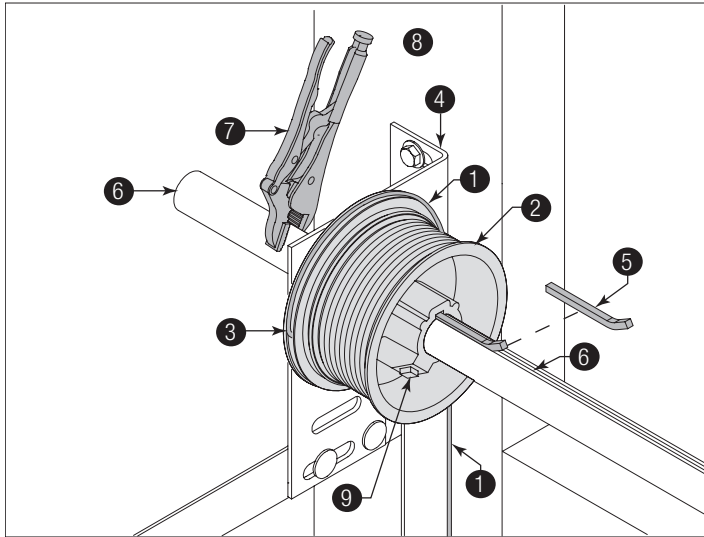

Figure 62, Left Side Shown

1	Counterbalance Lift Cable	7	Locking Pliers
2	Cable Drum	8	Jamb
3	Hook	9	Set Screws
4	End Bearing Bracket	10	3 O'Clock Position
5	Key	11	6 O'Clock Position
6	Torsion Shaft / Torsion Keyed Shaft		

23 CHALKING TORSION SPRING(S)

NOTE: If your springs have stenciling, then skip this step.

See Figure 63 for the following steps.

23a. Draw a chalk line horizontally along the center of the torsion spring coils **1**. As the torsion spring is wound, the chalk line will create a spiral **2**. This spiral can be used to count and determine the number of turns that are applied on the torsion spring **3**.

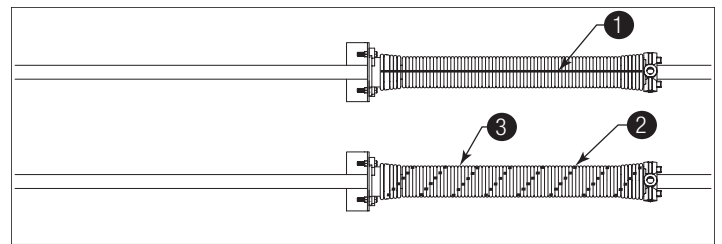

Figure 63

1	Draw horizontal chalk line prior to winding	3	Spirals created after winding
2	Spiral		

24 SECURING DOOR FOR SPRING WINDING

See Figure 64 for the following steps.

24a. With the door in the fully closed position, place locking pliers **4** onto both vertical tracks **1** and **2** just above the third track roller **3**. This is to prevent the garage door from rising while winding spring(s). Ensure that:

24b. **Check the following before attempting to wind torsion spring(s):**

- Counterbalance lift cables are secured at bottom corner brackets, See Figure 13 through Figure 15.
- Counterbalance lift cables are unobstructed in their route to cable drums.
- Counterbalance lift cables are correctly installed and wound onto cable lift drums.
- Counterbalance lift cables are taut and have equal tension on both sides.
- Cable lift drums are against end bearing brackets and set screws are tight.
- Torsion spring or springs are installed correctly.
- Review the label attached to the spring warning tag, to determine number of spring turns required.

! WARNING

FAILURE TO PLACE LOCKING PLIERS ONTO VERTICAL TRACKS CAN ALLOW DOOR TO RAISE DURING SPRING WINDING AND CAUSE SEVERE OR FATAL INJURY.

! CAUTION

TO AVOID POSSIBLE DAMAGE TO YOUR DOOR, THE DOOR MUST BE CLOSED AND LOCKED WHEN WINDING OR MAKING ANY ADJUSTMENTS TO THE SPRING(S).

Winding Bars (Steel Rods)	Size Of Winding Bar (Inches)	Spring Inner Diameter Used On
—	1/2" dia. x 18"	2" and 2-5/8"
	5/8" dia. x 24"	3-3/4"

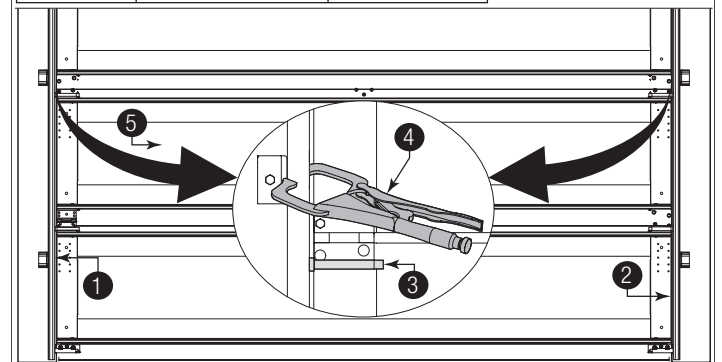

Figure 64

1	Left Side Vertical Track	5	Bottom Section
2	Right Side Vertical Track	6	Second Section
3	Track Roller	7	Intermediate Section
4	Locking Pliers		

25 WINDING SPRING(S)

! DANGER

WINDING SPRING IS AN EXTREMELY DANGEROUS PROCEDURE AND SHOULD BE PERFORMED ONLY BY A TRAINED DOOR SYSTEM TECHNICIAN USING PROPER TOOLS AND INSTRUCTIONS.

! WARNING

USE ONLY SPECIFIED WINDING BARS, AS STATED IN STEP SECURING DOOR FOR SPRING WINDING. DO NOT SUBSTITUTE WITH SCREWDRIVERS, PIPE, ETC. OTHER TOOLS MAY FAIL OR RELEASE FROM THE SPRING CONE AND CAUSE SEVERE OR FATAL INJURY.

! DANGER

PRIOR TO WINDING THE SPRING, ENSURE YOU'RE WINDING IN THE PROPER DIRECTION AS SHOWN IN FIGURE 65. OTHERWISE THE SPRING FITTING MAY RELEASE FROM SPRING AND RESULT IN SEVERE OR FATAL INJURY.

25a. Position a ladder slightly to the side of the spring so that the winding cone is easily accessible, and so your body is not directly in line with the winding bars **1**.

25b. Check the label attached to the spring warning tag **2** for the required number of complete turns to balance your door.

How to Wind Torsion Springs:

1. Insert one winding rod snugly into winding cone **3**, to full socket depth.
2. Maintaining a tight grip on the winding rod rotate it slowly in the proper direction **4**, as shown below.
3. If there is any slippage of the winding rod in the winding cone socket, reverse the direction of winding and return the cone to its original position. Remove the winding rod from the winding cone socket. Reseat the winding rod in the socket. Start over at Step #1.
4. When the winding rod is vertical above the winding cone, insert another winding rod into one of the other sockets, being careful to seat it snugly and at full socket depth.
5. Hold the spring with the second winding bar, and remove the first.
6. Repeat Steps #2 through #5 until the complete turns have been applied.

IMPORTANT: Check the warning tag(s) attached to the spring(s) for the required number of complete turns, to balance your door.

IMPORTANT: After winding the spring(s), tighten the set screws **5** in the winding cone to 14-15 ft-lbs of torque (once set screws contact the torsion shaft **6**, tighten screws an additional 1/2 turn for solid shaft and one full turn for tubular shaft).

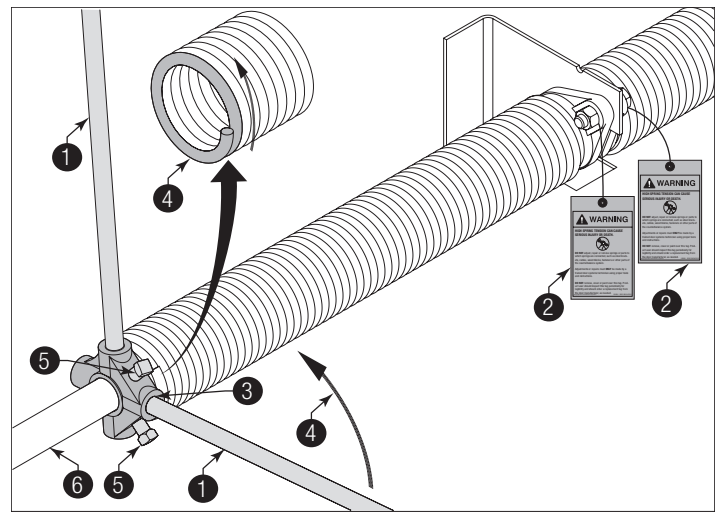

Figure 65

1	Approved Winding Rods	4	Proper Direction
2	Spring Warning Tag	5	Set Screws
3	Winding Cone	6	Torsion Shaft

26 ATTACHING REAR BACK HANGS (NOT INCLUDED)

! WARNING

IN THE EVENT THE SPRING(S) WERE OVER-WOUND, HOLD THE DOOR DOWN FIRMLY AND CAUTIOUSLY REMOVE LOCKING PLIERS FROM VERTICAL TRACKS TO PREVENT IT FROM RISING UNEXPECTEDLY.

See Figures 66, 67, and 68 for the following steps.

26a. Raise the door until the top section and half of the next section are in the horizontal track radius. Do not raise door any further since rear of horizontal tracks are not yet supported.

! WARNING

RAISING THE DOOR FURTHER INTO THE LOOSE HORIZONTAL TRACKS CAN RESULT IN DOOR FALLING CAUSING DEATH OR SERIOUS INJURY.

IMPORTANT: If an opener is installed, position horizontal tracks one hole above level when securing them to the rear back hangs.

26b. Using the chart below, select the appropriate perforated angle. Fabricate and install rear back hangs, as shown.

Perforated Angle Gauge Weight Limitations:	
Perforated Angle Gauge	Door Balance Weight
2" x 2" x 12 Gauge	800 lbs. to 1600 lbs.
1-1/4" x 1-1/4" x 13 Gauge	305 lb. to 610 lb.
1-1/4" x 1-1/4" x 15 Gauge	220 lb. to 440 lb.
1-1/4" x 1-1/4" x 16 Gauge	175 lb. to 350 lb.

! WARNING

KEEP HORIZONTAL TRACKS PARALLEL AND WITHIN 3/4" TO 7/8" (19 MM - 22 MM) MAXIMUM OF DOOR EDGE. OTHERWISE THE TRACK ROLLERS CAN COME OUT AND DOOR WILL FALL, RESULTING IN DEATH OR SERIOUS INJURY.

WARNING

MAKE SURE BACK HANGS ARE BRACED SUFFICIENTLY TO RESIST ANY MOTION DURING SPRING APPLICATION AND DOOR TRAVEL. IF BACK HANGS PIVOT OR DEFLECT, ADD REINFORCEMENT UNTIL THEY REMAIN FIRM AND STATIONARY. ANY BACK HANG THAT HAS BEEN BENT MUST BE REPLACED. FAILURE TO SECURELY BRACE THE HORIZONTAL TRACK CAN RESULT IN DOOR FALLING CAUSING DEATH OR SERIOUS INJURY.

NOTICE

DO NOT SUPPORT THE WEIGHT OF THE DOOR ON ANY PART OF THE REAR BACK HANGS THAT IS 4" (102 MM) OR MORE BEYOND A SOUND FRAMING MEMBER.

NOTICE

IF REAR BACK HANGS ARE TO BE INSTALLED OVER DRYWALL, USE TWO 5/16" X 2" HEX-HEAD LAG SCREWS AND MAKE SURE LAG SCREWS ENGAGE INTO SOLID STRUCTURAL LUMBER.

DANGER

FAILURE TO ASSEMBLE AND ATTACH REAR BACK HANGS PROPERLY ACCORDING TO THE ABOVE INSTRUCTIONS MAY RESULT IN DOOR FALLING WHEN RAISED, CAUSING DEATH OR SERIOUS INJURY.

NOTICE

PERFORATED ANGLE MUST BE ATTACHED TO SOUND FRAMING MEMBERS AND NAILS SHOULD NOT BE USED.

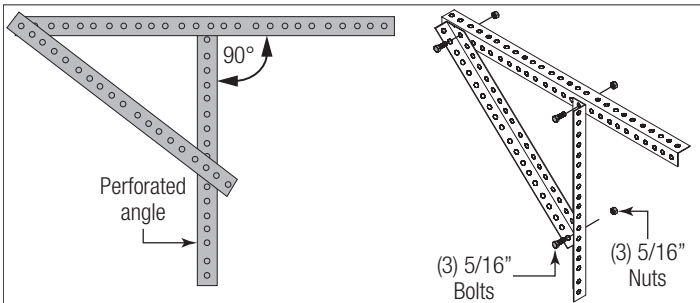

Figure 66

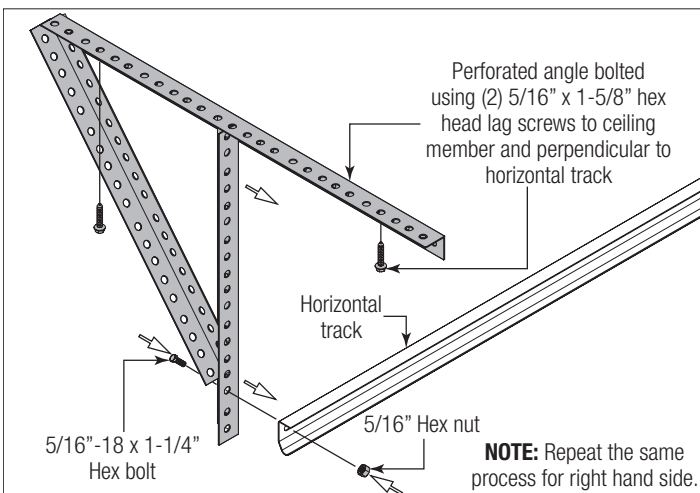

Figure 67

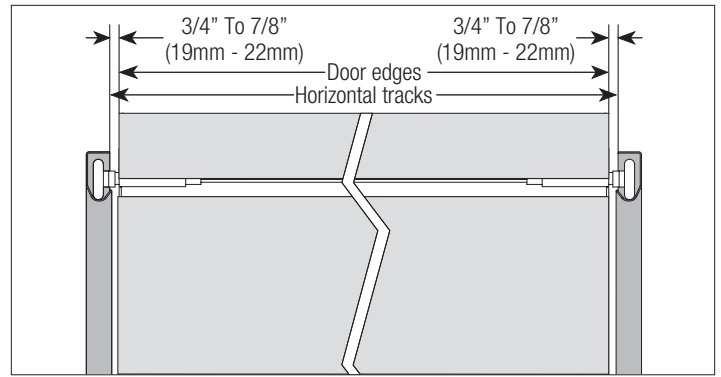

Figure 68

27 CABLE KEEPERS

NOTE: If you don't have cable keepers, then skip this step. Refer to Step Attaching Cable Keepers, to determine if you have cable keepers installed.

IMPORTANT: Cable keepers ① are intended to help prevent counterbalance lift cables from coming off cable drums on manually operated doors. Additional cable tensioning provisions may be required for motor operated doors.

See Figure 69 for the following steps.

27a. Starting on the left hand side, rotate arm ② up and hook around counterbalance lift cable ③, letting the cable keeper arm pull against the counterbalance lift cable, keeping it taut.

27b. Close the hook ④ to prevent the counterbalance lift cables from coming out.

27c. Repeat same process for right hand side.

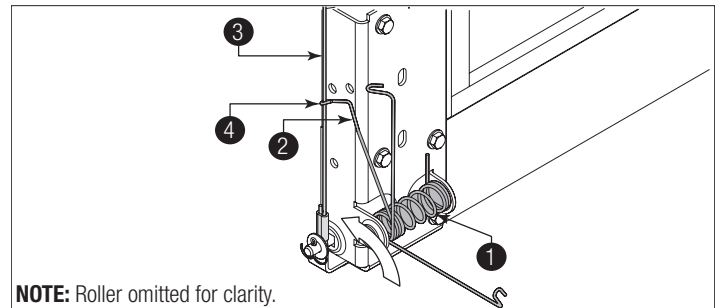

NOTE: Roller omitted for clarity.

Figure 69

1	Cable Keepers	3	Counterbalance Lift Cable
2	Rotate Arm	4	Close The Hook

28 ATTACHING WEATHERSTRIPS (NOT INCLUDED)

NOTICE

WHEN PERMANENTLY ATTACHING THE WEATHERSTRIPS TO THE JAMBS, AVOID PUSHING THE WEATHER-STRIPS TOO TIGHTLY AGAINST THE FACE OF DOOR.

See Figure 70 for the following steps.

28a. Permanently attach the nails to the weatherstrips on both door jambs ① and the header ②. The weatherstrips were temporarily attached in Preparing the Opening, in the pre-installation section of this manual.

NOTE: For clarity, door isn't shown.

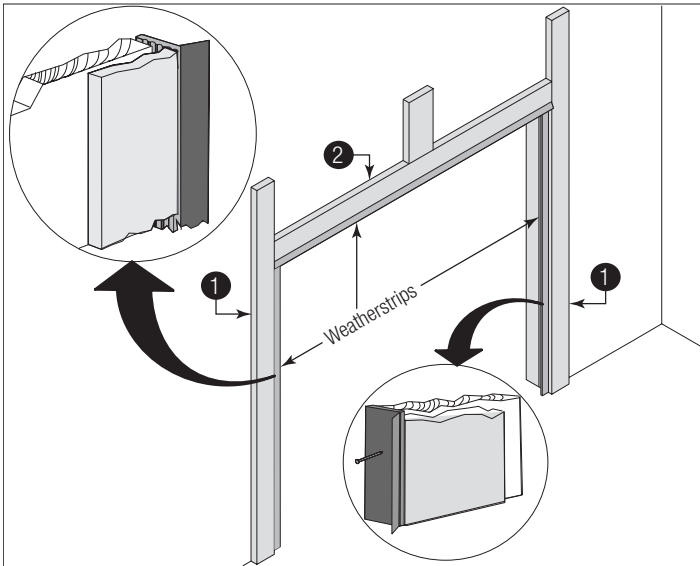

Figure 70, Weatherstrips

1	Door Jambs	2	Header
---	------------	---	--------

29 BALANCING DOOR

CAUTION

WINDOWS MAY CAUSE THE TOP SECTION TO BE SIGNIFICANTLY HEAVIER THAN THE REMAINING SECTIONS. TO PREVENT ANY SUDDEN DOOR ACCELERATION BETWEEN THE TOP AND BOTTOM, MOTOR OPERATE ALL DOORS WITH WINDOWS.

DANGER

EXTREME CAUTION SHOULD BE USED WHEN MAKING ADJUSTMENTS TO THE SPRINGS AS FAILURE TO FOLLOW THE INSTRUCTIONS OR USE APPROVED WINDING BARS CAN LEAD TO DEATH OR SERIOUS INJURY TO PERSONS OR PROPERTY. BEFORE ATTEMPTING TO MAKE ADJUSTMENTS TO THE SPRING, MAKE SURE YOU HAVE READ AND UNDERSTAND THE INSTRUCTIONS. IF YOU ARE UNCLEAR ON ANY ASPECT OF THE INSTALLATION PROCEDURES, YOU SHOULD CONSULT A TRAINED DOOR SYSTEMS TECHNICIAN.

See Figure 71 for the following steps.

29a. Remove locking pliers. Lift door and check its balance. Adjustments to the required number of spring turns stated may be necessary. If door rises off floor more than 2 ft. under spring tension alone, reduce spring tension. If the door is hard to rise or drifts down on its own, add spring tension. A poorly balanced door can cause garage door operator problems.

29b. To adjust spring tension, fully close door. Apply locking pliers to track above third track roller. Place locking pliers on torsion shaft, as shown in Step Attaching Counterbalance Lift Cables. Insert a winding rod ① into the winding cone. Push upward on the winding rod slightly while carefully loosening the set screws ② in the winding cone ③.

WARNING

BE PREPARED TO SUPPORT THE FULL FORCE OF THE TORSION SPRING ONCE THE SET SCREWS ARE LOOSE. IF NOT PREPARED, THEN THE WINDING BAR CAN MOVE SUDDENLY AND COME OUT OF THE WINDING CONE AND CAUSE SEVERE OR FATAL INJURY.

Carefully adjust spring tension 1/4 turn. Retighten both set screws to 14-15 ft. lbs. of torque in the winding cone and repeat for the other side. Recheck door balance and re-adjust spring tension if needed.

IMPORTANT: Do not adjust more than 1 turn from the recommended number of turns.

If the door still does not operate easily, lower the door into the closed position, unwind spring(s) completely, and recheck the following items:

29c. Is the door level?

29d. Are the torsion shaft and flag angles / angle mount level and plumb?

29e. Does the distance between the flag angles / angle mount equal door width plus 3-3/8" to 3-1/2"?

29f. Do the counterbalance lift cables have equal tension? Adjust if necessary.

29g. Rewind the spring(s).

29h. Make sure door is not rubbing on jambs.

IMPORTANT: If door still does not balance properly, then contact a trained door system technician.

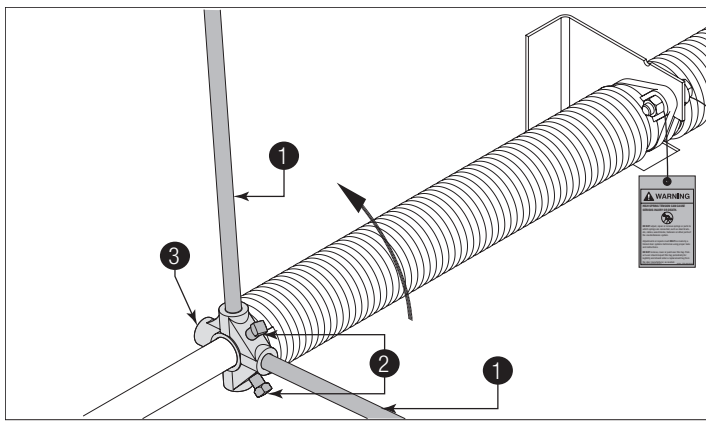

Figure 71

1	Winding Rod	3	Winding Cone
2	Set Screws		

OPTIONAL INSTALLATION

Inside Lock

IMPORTANT: Inside lock(s) must be removed or made inoperative in the unlocked position if an operator is installed on this door.

Install the inside lock on the second section of the door. Secure the lock to the section with (4) 1/4" - 20 x 5/8" self drilling screws. Square the lock assembly with the door section, and align with the square hole in the vertical track. The inside lock should be spaced approximately 1/8" away from the section edge.

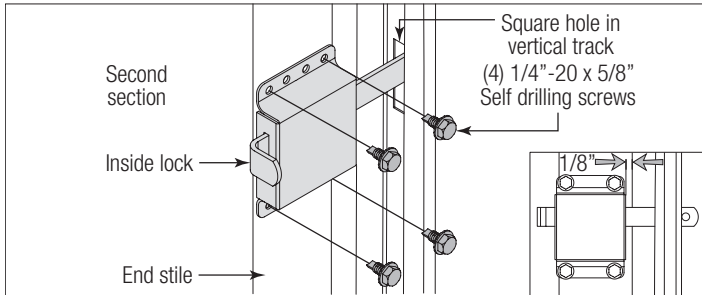

Step Plate

Position your step plate on the inside of the door over the bottom section endstile and on the side of the door containing the side lock. Secure the step plate to endstile using (2) 1/4" - 20 x 5/8" self-drilling screws, as shown. For doors ordered with non-keyed locks, a second step plate is provided. Install the second step plate in the same manner as the first on the lock section (second section), below the side lock.

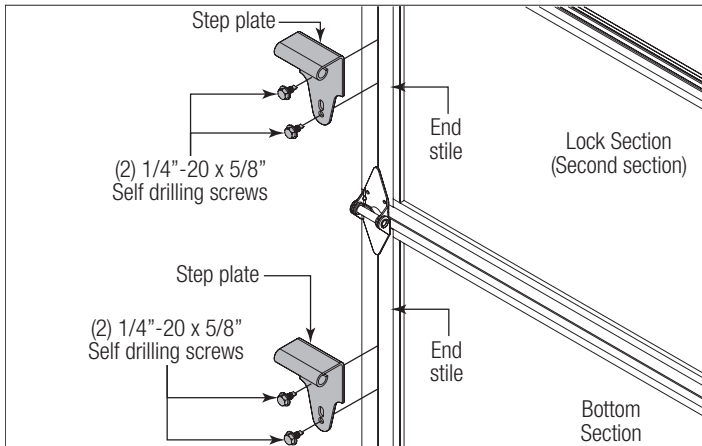

Exhaust Port

NOTE: The exhaust port goes on the inside of the bottom section and can be installed into the aluminum panel or on a double wide bottom rail.

Using the illustrations below, locate and install the exhaust port assembly to the bottom section, using #10 counter sunk bolts and #10 hex nuts, as shown.

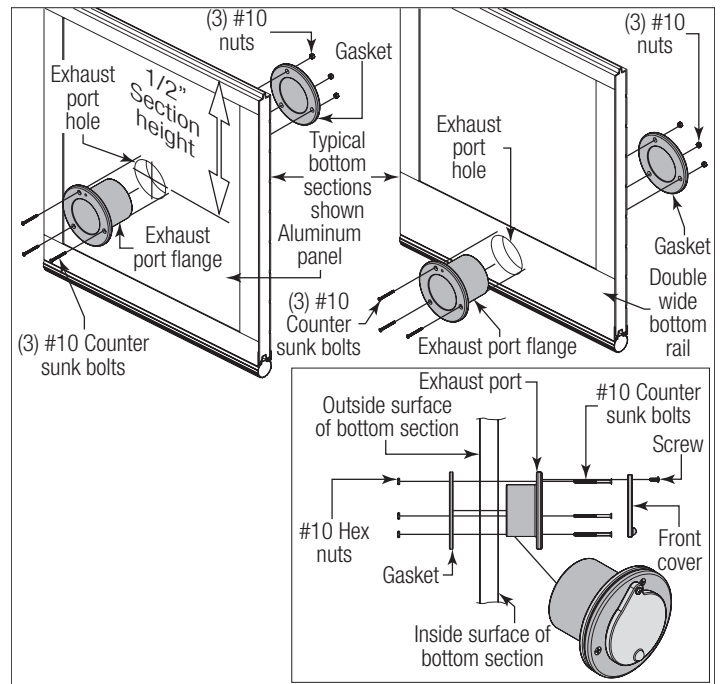

Chain Hoist

Chain Hoist Installation (Standard Lift Applications only!)

NOTE: Reference separate instructions for Chain Hoists and Jack Shaft Operators installation instruction.

Chain Hoists and Jack Shaft Operators are limited to:

- 1.) Standard Lift Doors with roof pitch track 2:12 or greater.
- 2.) High Lift track greater than or equal to 24".
- 3.) High Lift track 12" thru 24" with roof pitch track 1:12.

IMPORTANT: If chain hoist operated with auxiliary trolley operated, it is recommended that an optional strut be installed on the top section.

! WARNING

WAYNE DALTON RECOMMENDS THE USE OF A TROLLEY RAIL(S) AND AUXILIARY SHAFT FOR STANDARD OR HIGH LIFT DOORS BELOW THESE LIMITS. CABLE KEEPERS ARE RECOMMENDED FOR ALL CHAIN HOIST OR JACKSHAFTS OPERATORS. INSTALL THE CHAIN HOIST OR SPROCKET AS CLOSE TO THE END BEARING BRACKET AS POSSIBLE, TO MINIMIZE TORSION SHAFT DEFLECTION. CHAIN TENSIONERS ARE RECOMMENDED FOR DOORS OVER 144 SQ. FT. WITH JACKSHAFT OPERATORS.

! WARNING

WAYNE DALTON RECOMMENDS THE USE OF A TROLLEY RAIL(S) COUPLED TO AN AUXILIARY SHAFT THAT IS POWERED BY A SIDE MOUNT TYPE CHAIN HOIST.

NOTE: 9" of extra headroom are required for these installations.

Assemble the trolley rail as per the manufactures installation instructions.

NOTE: Back hang the trolley using angles, center hang supports are required for doors over 14' wide and 12' high.

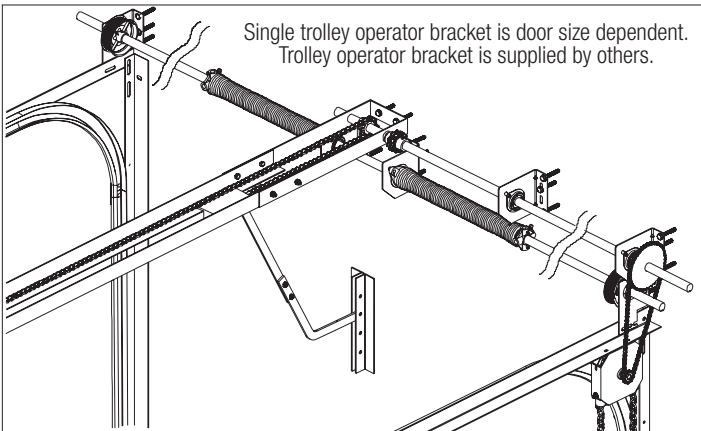
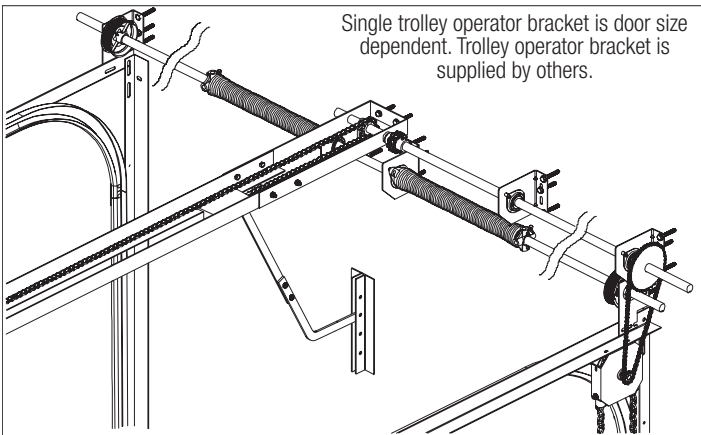
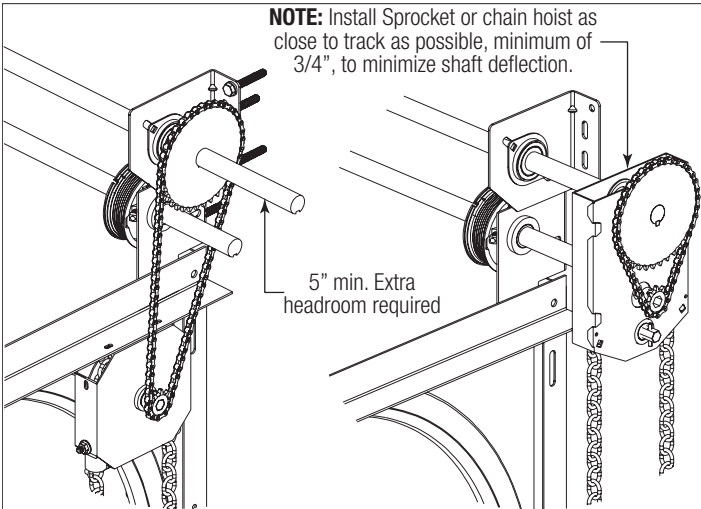
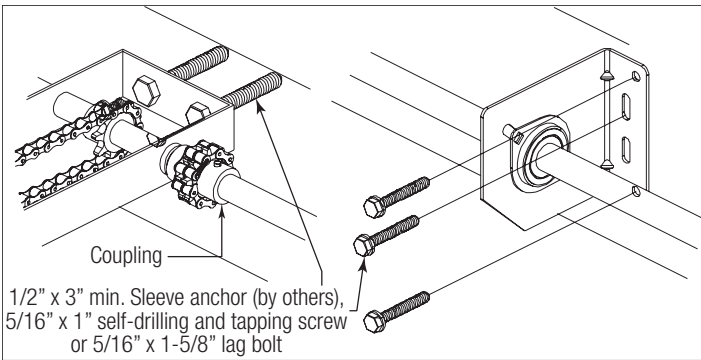

Pusher Springs

IMPORTANT: Right and left hand is always determined from inside the building looking out.

Raise the door to the open position. Mark the locations of the top section on the top portion of the horizontal tracks. Close the door. Starting on the left hand side, clamp pusher spring mounting bracket to the top portion of the horizontal track 6" to 7" away from the top section mark. Mark the two hole locations onto the horizontal track for the pusher spring mounting bolts. Remove pusher spring and drill 3/8" diameter holes through the top portion of the horizontal track. Assemble pusher spring to the track using (2) 3/8" - 16 x 3/4" hex head bolts, 3/8" washers and 3/8" - 16 flanged hex nuts. Repeat same process for the right hand side. Open door cautiously to test pusher spring installation location.

NOTE: The (2) 3/8" - 16 x 3/4" hex head bolts may extend into the horizontal track.

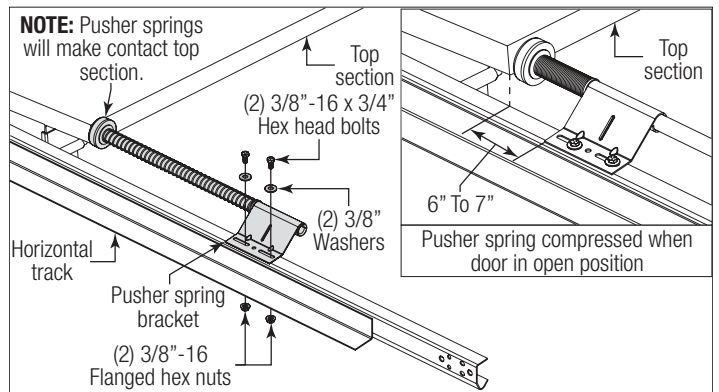

Cleaning Your Garage Door

Like any other exterior surface, Wayne Dalton garage doors will have dirt exposure from atmospheric conditions. Ordinarily, the cleaning action of rainfall will be adequate to wash the door, or the door can be washed periodically by hosing with a garden hose and clear water (in particular) for the areas not accessible to rain. If you desire to do a more thorough cleaning, or where soil collection conditions occur, follow these simple instructions.

1. To clean acrylic glazings wash with plenty of nonabrasive soap or detergent and water. Use the bare hand to feel and dislodge any caked dirt or mud. A soft, grit-free cloth, sponge or chamois may be used to wipe the surface. Do not use hard or rough cloth that will scratch the acrylic glazing. Dry with a clean damp chamois.

2. Grease and oil may be removed with kerosene or a good grade of naphtha (No aromatic content.). Users of these solvents should become familiar with their proper ties to handle them safely.

Mild solutions of detergents or household ammonia will aid in the removal of most dirt, and the following are recommended levels:

One cup of Tide™, or other common detergents, which contain less than 0.5% phosphate, dissolved into five gallons of warm water.

IMPORTANT: If you have door Model 8450, the use of bleach will void the warranty.

NOTE: The use of detergents containing greater than 0.5% phosphate is not recommended for use in general cleaning of garage doors. NEVER BLEND CLEANSERS OR DETERGENTS WITH BLEACH.

3. **Do not use:** Window cleaning fluids, scouring compounds, gritty cloths, leaded or ethyl gasoline, or solvents such as alcohol, acetone, carbon tetrachloride, etc.

This cleaning and maintenance information is suggested in an effort to be of assistance; however, manufacturer cannot assume responsibility for results obtained which are dependent on the cleaning solution and method of application.

Operation And Maintenance

Operating Your Garage Door:

Before you begin, read all warning labels affixed to the door and the installation instructions and owner's manual. When correctly installed, your Wayne Dalton door will operate smoothly. Always operate your door with controlled movements. Do not slam your door or throw your door into the open position, this may cause damage to the door or its components. If your door has an electric opener, refer to the owner's manual to disconnect the opener before performing manual door operation below.

Manual Door Operation:

For additional information on manual garage door operation go to www.dasma.com and reference TDS 165.



DO NOT PLACE FINGERS OR HANDS INTO SECTION JOINTS WHEN OPENING AND/OR CLOSING A DOOR. ALWAYS USE LIFT HANDLES/SUITABLE GRIPPING POINTS WHEN OPERATING THE DOOR MANUALLY.

OPENING A DOOR: Make sure the lock (if present) are in the unlocked position. Lift the door by using the lift handles/suitable gripping points only. Door should open with little resistance.

CLOSING A DOOR: From inside the garage, pull door downward using lift handles/ gripping points only. If you are unable to reach the lift handles/suitable gripping points only, use pull-down rope (if present) affixed to the side of door. Door should close completely with little resistance.

Using An Electric Operator:

IMPORTANT: If present, Pull-down rope must be removed and locks must be removed or made inoperative in the unlocked position.

When connecting a drawbar (trolley-type) garage door operator to this door, a drawbar operator bracket must be securely attached to the top section of the door, along with any struts provided with the door. Always use the drawbar operator bracket supplied with the door. To avoid possible damage to your door, reinforce the top section with a strut (may or may not be supplied). The installation of the drawbar operator must be according to manufacturer's instructions and force settings must be adjusted properly. Refer to the owner's manual supplied with your drawbar operator for complete details on installation, operation, maintenance and testing of the operator.

Maintaining Your Garage Door:

Before you begin, read all warning labels affixed to the door and the installation instructions and owner's manual. Perform routine maintenance steps once a month, and have the door professionally inspected once a year. Review your Installation Instructions and Owner's Manual for the garage door. These instructions are available at no charge from Wayne Dalton, a division of Overhead Door Corporation, P.O. Box 67, Mt. Hope, OH, 44660, or at www.Wayne-Dalton.com. For additional information on garage door/operator maintenance go to www.dasma.com and reference TDS 151, 167 and 179.

Monthly Inspections:

1. Visual Inspection:

Closely inspect jambs, header and mounting surface. Any material found not to be structurally sound must be replaced. It may be necessary to uninstall part or all of the door assembly in order to replace defective material. Inspect the spring(s), counterbalance lift cables, track rollers, pulleys, rear back hangs and other door hardware for signs of worn or broken parts. Tighten any loose screws and/or bolts, except on bottom corner brackets or on the counterbalance assembly. Check exterior surface of the door sections for any minor cracks. Verify door has not shifted right or left in the opening. If you suspect problems, contact a trained door system technician.

⚠ DANGER

GARAGE DOOR SPRINGS, COUNTERBALANCE LIFT CABLES, BRACKETS, AND OTHER HARDWARE ATTACHED TO THE SPRINGS ARE UNDER EXTREME TENSION, AND IF HANDLED IMPROPERLY, CAN CAUSE DEATH OR SERIOUS INJURY. ONLY A TRAINED DOOR SYSTEMS TECHNICIAN SHOULD ADJUST THEM, BY CAREFULLY FOLLOWING THE MANUFACTURER'S INSTRUCTIONS.

⚠ WARNING

NEVER REMOVE, ADJUST, OR LOOSEN THE BOLTS, SCREWS AND/OR LAG SCREWS ON THE COUNTERBALANCE (END BEARING BRACKETS, DRUMS OR SPRING SYSTEM) OR BOTTOM CORNER BRACKETS OF THE DOOR. THESE BRACKETS ARE CONNECTED TO THE SPRING(S) AND ARE UNDER EXTREME TENSION. TO AVOID POSSIBLE DEATH OR SERIOUS INJURY, HAVE ANY SUCH WORK PERFORMED BY A TRAINED DOOR SYSTEMS TECHNICIAN USING PROPER TOOLS AND INSTRUCTIONS.

Torsion Springs:

The torsion springs (located above the door) should only be adjusted by a trained door systems technician. **DO NOT** attempt to repair or adjust torsion springs yourself.

2. Door Balance:

Periodically test the balance of your door. If you have a garage door drawbar operator, use the release mechanism so you can operate the door by hand when doing this test. Start with the door in the fully closed position. Using handles or suitable gripping points, lift the door to check its balance. If door lifts by itself (hard to pull down) or if door is difficult to lift (easy to pull down), have it adjusted by a trained door systems technician. **DO NOT** attempt to repair or adjust Torsion Springs yourself.

3. Lubrication:

The door should open and close smoothly. Ensure the door track rollers are rotating freely when opening and closing the door. If track rollers do not rotate freely, clean the door tracks, removing dirt and any foreign substances. Clean and lubricate (use a non-silicon based lubricant) graduated end hinges, center hinges, steel track rollers, bearings and torsion springs (torsion spring coil surfaces). **DO NOT** lubricate plastic idler bearings, nylon track rollers, or the door track. **DO NOT** oil a cylinder lock. If actuation is difficult, use a graphite dust to lubricate.

Check for Presence of Safety Labels:

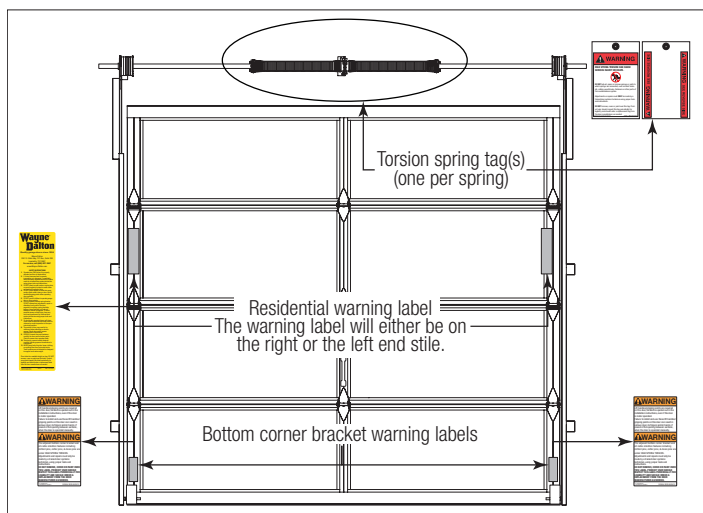



Models 8450 LUMINOUS[®], 8850, 464, 451, and 452 Limited Warranty

Wayne Dalton, a division of Overhead Door Corporation ("Seller") warrants to the original purchaser of the Full-View Models 8450, 8850, 464, 451 or 452 Doors ("Product"), subject to all of the terms and conditions hereof, that the Product and all components thereof will be free from defects in materials and workmanship for the following period(s) of time, measured from the date of installation:

- **ONE (1) YEAR** against defects in materials and workmanship

Seller's obligation under this warranty is specifically limited to repairing or replacing, at its option, any part which is determined by Seller to be defective during the applicable warranty period. Any labor charges are excluded and will be the responsibility of the purchaser.

This warranty is made to the original purchaser of the Product only, and is not transferable or assignable. This warranty does not apply to any unauthorized alteration or repair of the Product, or to any Product or component which has been damaged or deteriorated due to misuse, neglect, accident, failure to provide necessary maintenance, normal wear and tear, acts of God, or any other cause beyond the reasonable control of Seller or as a result of having been exposed to toxic or abrasive environments, including blowing sand, salt water, salt spray and toxic chemicals and fumes.

THIS WARRANTY IS EXCLUSIVE AND IN LIEU OF ANY OTHER WARRANTIES, EITHER EXPRESS OR IMPLIED, INCLUDING BUT NOT LIMITED TO ANY IMPLIED WARRANTY OF MERCHANTABILITY OR FITNESS FOR A PARTICULAR PURPOSE.

IN NO EVENT SHALL SELLER BE RESPONSIBLE FOR, OR LIABLE TO ANYONE FOR, SPECIAL, INDIRECT, COLLATERAL, PUNITIVE, INCIDENTAL OR CONSEQUENTIAL DAMAGES, even if Seller has been advised of the possibility of such damages. Such excluded damages include, but are not limited to, loss of use, cost of any substitute product, or other similar indirect financial loss.

Claims under this warranty must be made promptly after discovery, within the applicable warranty period, and in writing to the authorized dealer or installer whose name and address appear below. The purchaser must allow Seller a reasonable opportunity to inspect any Product claimed to be defective prior to removal or any alteration of its condition. Proof of the purchase and/or installation date, and identification as the original purchaser, may be required.

SELLER: _____

SELLER'S ADDRESS: _____

Thank you for your purchase.

If you need assistance, please call 1-866-569-3799 (press Option 1) and follow the prompts to contact a customer service representative. They will be happy to handle any questions that you may have.

After installation is complete, leave this Installation Instructions And Owner's Manual with the homeowner, or fasten it near garage door for easy reference.

Product may be covered by one or more patents.
See www.wayne-dalton.com/patents for details.