

INSTALLATION INSTRUCTIONS MODEL DS-200 ROLL-UP DOORS, WITH SIDE MOUNT OPERATOR



Wayne
 **Dalton**[®]
GARAGE DOORS

This installation manual provides the trained door technician information required to install this door.

READ COMPLETE INSTRUCTIONS BEFORE INSTALLING DOOR.

Some installation tasks listed in this document are found in other documents.

Please refer to the appropriate document(s) as directed;

**Expansion Anchor Requirement
500460-0001 found on
www.Wayne-Dalton.com**

**41510.00119 Operator Installation
Instructions (Included)**

This manual is intended ONLY for professional use by a trained door systems technician. All others please refer to the end user manual provided to you.

Product may be covered by one or more patents. See www.wayne-dalton.com/patents for details.



TABLE OF CONTENTS		
SECTION	CONTENTS	PAGES
1	SAFETY INFORMATION	3
2	KEY DRAWING	4
3	DOOR INSTALLATION DATA SHEET	5
4	PRE-INSTALLATION CHECK LIST	6-7
5	DOOR INSTALLATION	8-19
	WARRANTY	20

SECTION 1 - SAFETY INFORMATION

IMPORTANT SAFETY INSTRUCTIONS

⚠ WARNING

ROLLING DOORS ARE LARGE, HEAVY OBJECTS THAT MOVE WITH THE HELP OF ELECTRIC MOTORS. SINCE MOVING OBJECTS AND ELECTRIC MOTORS CAN CAUSE INJURIES, YOUR SAFETY AND THE SAFETY OF OTHERS DEPENDS ON YOU READING THE INFORMATION IN THIS MANUAL. IF YOU HAVE ANY QUESTIONS OR DO NOT UNDERSTAND THE INFORMATION PRESENTED, YOU SHOULD CONSULT A LICENSED PROFESSIONAL OR CALL TECHNICAL SUPPORT AT 1-800-764-1457.

DEFINITION OF KEY WORDS USED IN THIS MANUAL:

⚠ DANGER INDICATES A HAZARDOUS SITUATION THAT, IF NOT AVOIDED, WILL RESULT IN DEATH OR SERIOUS INJURY.

⚠ WARNING INDICATES A HAZARDOUS SITUATION THAT, IF NOT AVOIDED, COULD RESULT IN DEATH OR SERIOUS INJURY.



⚠ CAUTION INDICATES A HAZARDOUS SITUATION THAT, IF NOT AVOIDED, COULD RESULT IN MINOR OR MODERATE INJURY.

NOTICE

INDICATES INFORMATION CONSIDERED IMPORTANT, THAT IT IS NOT RELATED TO INJURY, BUT MAY RESULT IN PROPERTY DAMAGE.

IMPORTANT: Required key step for proper door operation.

NOTE: Information only.

Potential Hazard	Effect	Prevention
 <p>MOVING DOOR</p>	<p>⚠ WARNING COULD RESULT IN DEATH OR SERIOUS INJURY</p>	<p>Keep people clear of opening while Door is moving.</p> <p>Do NOT allow children to play with the Door Operator.</p> <p>Do NOT operate a Door that jams or one that has a broken spring.</p>
 <p>ELECTRICAL SHOCK</p>	<p>⚠ WARNING COULD RESULT IN DEATH OR SERIOUS INJURY</p>	<p>Turn OFF electrical power before wiring switch and door operator to supply.</p>
 <p>HIGH SPRING TENSION</p>	<p>⚠ WARNING COULD RESULT IN DEATH OR SERIOUS INJURY</p>	<p>Do NOT try to remove, install, repair or adjust springs or anything to which door spring parts are fastened, such as, wood blocks, steel brackets, cables or other like items.</p> <p>Installations, repairs and adjustments must be done by a trained door system technician using proper tools and instructions.</p>

SECTION 2 - KEY DRAWING

Please note that components and component locations are shown here for REFERENCE ONLY. Your unit installation and component locations may be different.

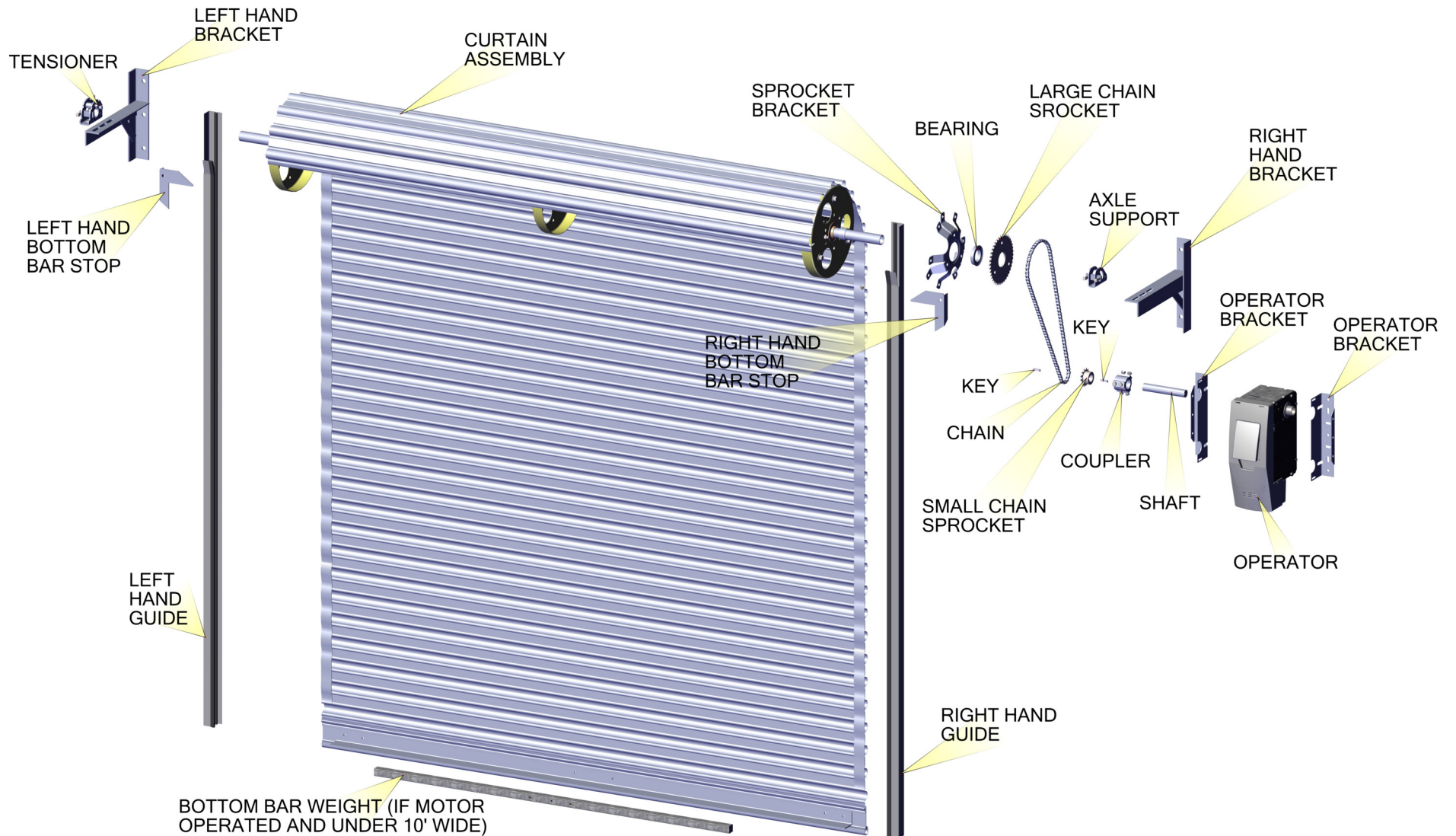

SECTION 3 - DOOR INSTALLATION DATA SHEET

A sample of the "DOOR INSTALLATION DATA" sheet is shown here. Locate the work order "Door Installation Data" sheet inside the door hardware box. You will need to refer to the "Door Installation Data" sheet. See FIG 2.

Factory order number on door components must match with factory order number on the "Door Installation Data" sheet. Each door has it's own individual sheet.

Jobless Installer Report

SO#	SO Line#:	SO Line Item:
Org Code:	Qty:	Desc:
Cust. PO:	Customer:	Customer Job:

Job Name:
 Schl'd Ship Dt:
 Product Desc:

CURTAIN:
 OPERATION:
 BOTTOM BAR:
 GUIDE:

HOOD/CRATE:

*****	DOOR	INSTALLATION	DATA#	*****	*****	*****	*****
MODEL:				S-REFERENCE:			
OPENING WIDTH:		OPENING HEIGHT:		HAND OF OPERATION:		GUIDE TYPE:	
INITIAL TURNS:		RELEASE TURN:		OPERATION TYPE:		CURTAIN/BOTTO MBAR WT:	
TOTAL TURNS:		OPER MODEL: / VOLTAGE:		DRIVE NO:		PIPE ASSEMBLY WT:	
GUIDE GAP:		OPERATION TYPE:		GUIDE FINISH:		BRACKET FINISH:	
***** WORK ORDER MESSAGES *****							
**							
**							
**							

FIG 2

SECTION 4 - PRE-INSTALLATION CHECK LIST

Verify that the door installation can be accomplished before proceeding:

- Locate the work order "DOOR INSTALLATION DATA" sheet, see FIG 2, inside the door hardware box.
- Does the wall opening shown in FIG 3 and FIG 4 match the Opening Width and Height shown on the "Door Installation Data" sheet?
- Are the guides you received suitable for the jambs? Compare the guides type shown in FIG 5 with the "Door Installation Data" sheet.
- Can the guides be installed plumb?
- Check the sill for level. If sill is not level, mark the high sill location on the low side jamb.
- Guides are designed to rest on sill.
- Consult the factory if the actual opening width is greater than shown on the packing slip more than 1-1/2 inches.

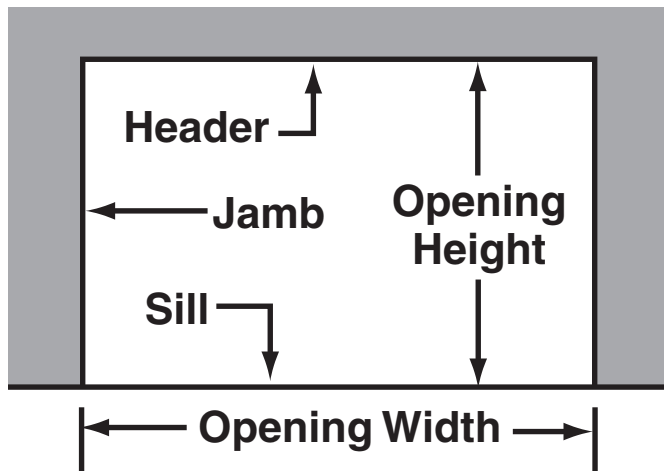
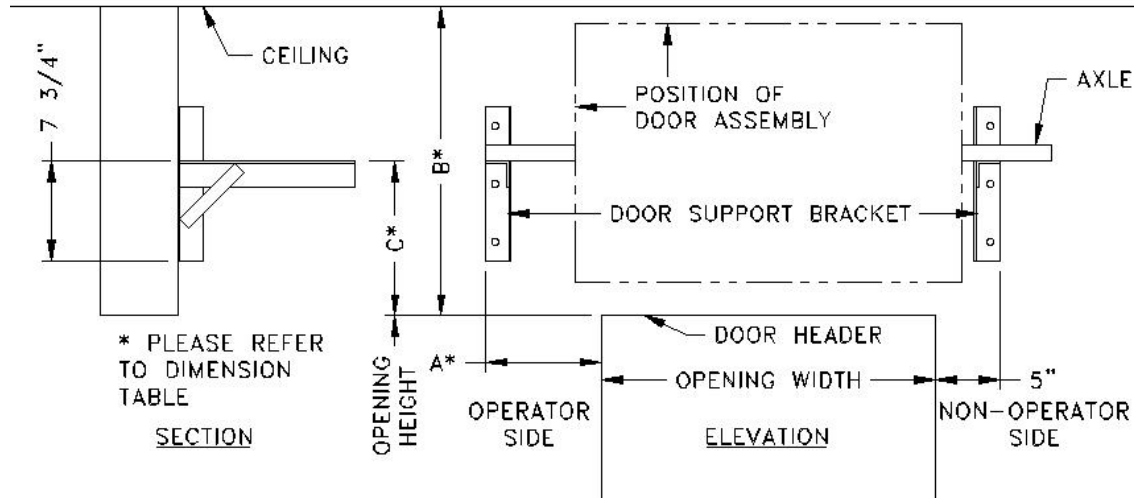

FIG 3



OPERATION	DIMENSION	OPENING HEIGHT	
	A	B	C
PUSH UP	5"	17"	7"
DIRECT DRIVE CHAIN / MOTOR	9"	19"	8"
REDUCED DRIVE CHAIN	8"	21"	9"

NOTE: DIMENSION TABLES - MINIMUM OVERHEAD CLEARANCE (B) INDICATED

FIG 4

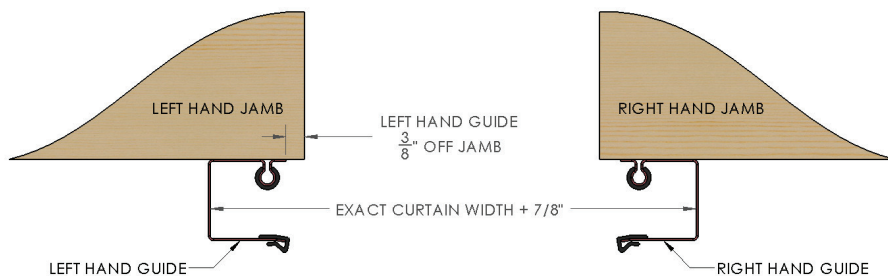
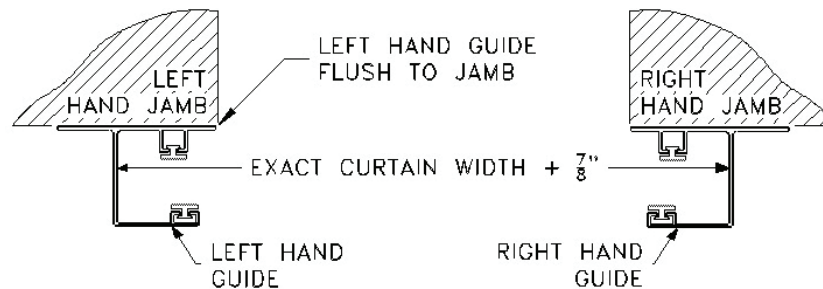

FIG 5



SECTION 4 - PRE-INSTALLATION CHECK LIST

Read the installation instructions thoroughly to become familiar with the names of the various components and their relation to each other. It is necessary for the installer to determine the following:

- Type of jamb material (wood, masonry, or steel) on which the door guides will be mounted.
- The dimensions for the opening width, opening height, headroom, and side room.

TOOLS

Commonly used tools for proper installation are:

- Electric drill with 3/8" or 1/2" chuck with nut driver and drill bits.
- Masonry drill or impact hammer and bits.
- Ladders and/or scaffolding.
- Hammer and pliers.
- Center punch and Screwdrivers.
- Wrenches, vise grips, and C-clamps.
- Tape measure and a water level.

FASTENER TABLE		
Jamb Condition	Bracket Fasteners	Guide Fasteners
Wood	5/16" x 1-1/2" Lag Screw	5/16" x 1-1/2" Lag Screw
Masonry	5/16" x 1-1/2" Wedge Anchor	1/4" x 1-3/4" Tapcon
Steel	1/4" x 3/4" Self Drilling Screw	1/4" x 3/4" Self Drilling Screw

UNPACKING DOORS

Before removing the door from any packaging, inspect the packaging for visible signs of damage. If damage is noted, file a freight claim with the freight company immediately. Remove the door from the packaging.

WARNING

DO NOT CUT TAPE THAT HOLDS DOOR IN A ROLL UNTIL INSTRUCTED TO DO SO.

NOTE: Right and Left Hand is determined by facing the door opening, on the coil side.

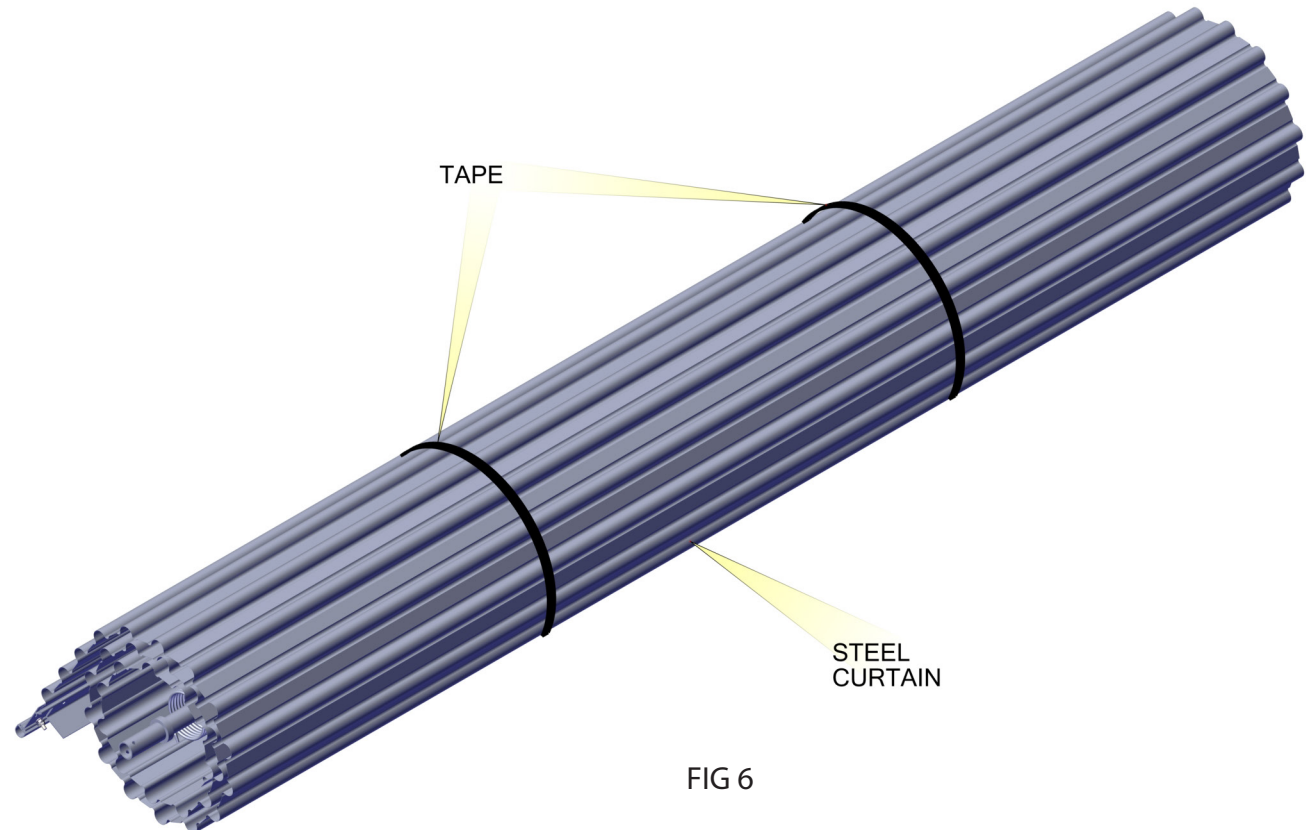
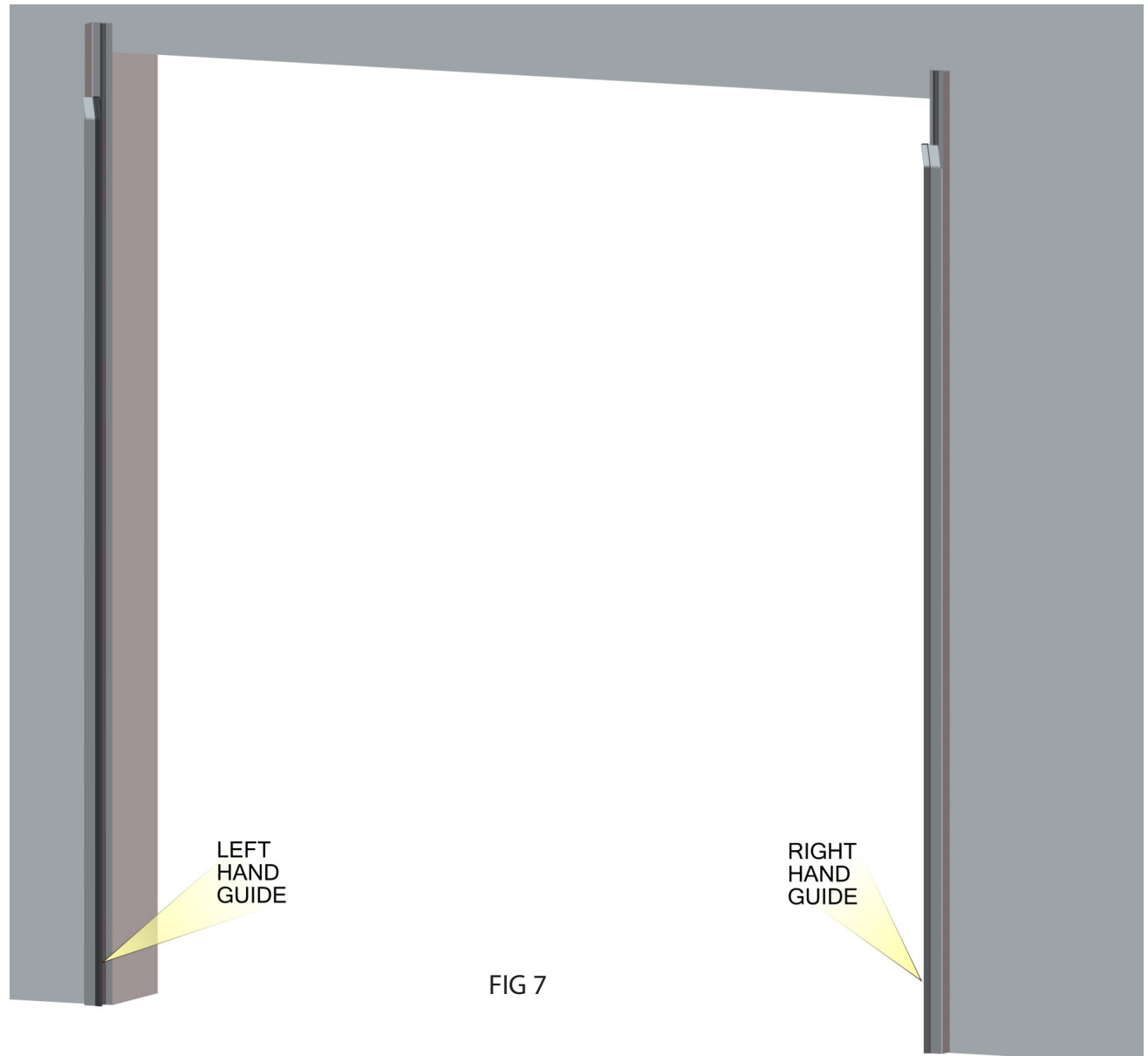

FIG 6

SECTION 5 - DOOR INSTALLATION

STEP 1 INSTALL CURTAIN GUIDES TO JAMB

- Mount curtain guides to the surface using supplied fasteners. See FIG 7.
- Check Dimensions as illustrated in FIG 4 on page 6. Dimensions must match your "DOOR INSTALLATION DATA" sheet.
- Both guides MUST be on a level line and both guides MUST be plumb.
- The Dimensions must be held within 1/8" over the entire height of the guides.



SECTION 5 - DOOR INSTALLATION

STEP 2 INSTALL BOTTOM BAR STOPS

- Install the bottom bar stops to the guides as shown using a 1/4"-20 x 5/8" carriage bolt and 1/4"-20 flange nut. Leave the fasteners loose to allow the bottom bar stops to pivot out of the way of the bottom bar angle when the curtain will be pulled into the guides. You will be instructed to tighten the bottom bar stop fasteners in STEP 6.

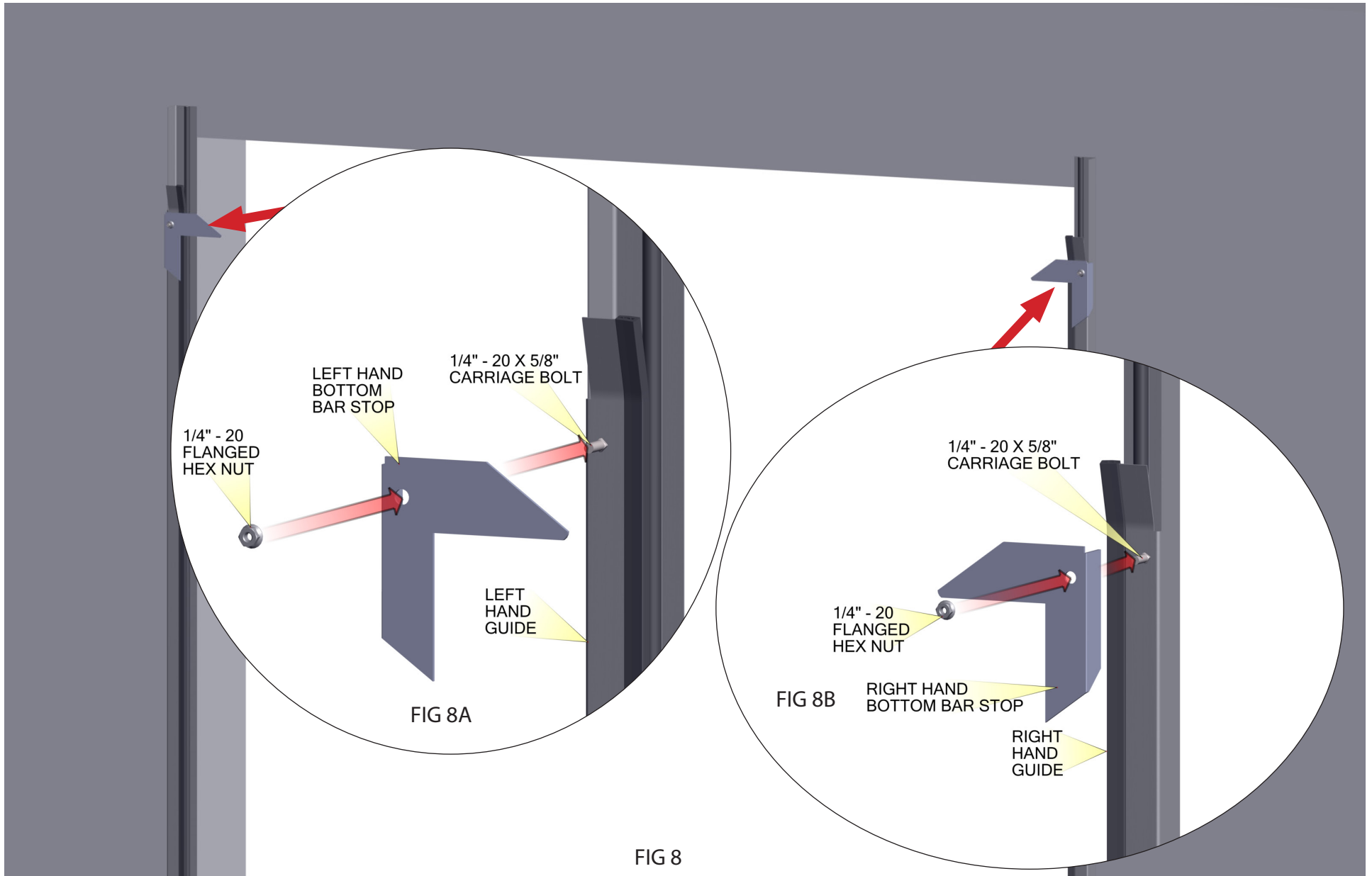

FIG 8

SECTION 5 - DOOR INSTALLATION

STEP 3 INSTALL BRACKETS

From the Dimension Tables in FIG 4, mark the width location of each bracket by using dimension A for the operator side and 5" for the non-operator side. If the actual opening width varies from the packing slip width, adjust these dimensions by adding or subtracting 1/2" of the difference to each dimension. Subtract if the opening is larger and add if smaller. Mark the height location of the brackets by using dimension C. Verify the ceiling clearance minimum from dimension B. Use a string and a level to verify that the brackets are level with each other. Adjust bracket height as needed to level. Drill anchor holes and fasten the brackets with the anchors provided.

IMPORTANT: BRACKETS MUST BE LEVEL TO EACH OTHER WITH RESPECT TO HEIGHT. FAILURE TO LEVEL BRACKET HEIGHTS WILL PREVENT DOOR FROM OPERATING PROPERLY.

If the door is to be chain hoist or motor operated, install the components shown below to the operator side of the curtain at this time. Do not tighten set screws at this time, you will be instructed to tighten these in step #8.

⚠ WARNING

KEEP LOOSE CLOTHING, FINGERS, HANDS AND ARMS AWAY FROM ALL MOVING MECHANISMS, OR SERIOUS INJURY OR DEATH COULD RESULT.

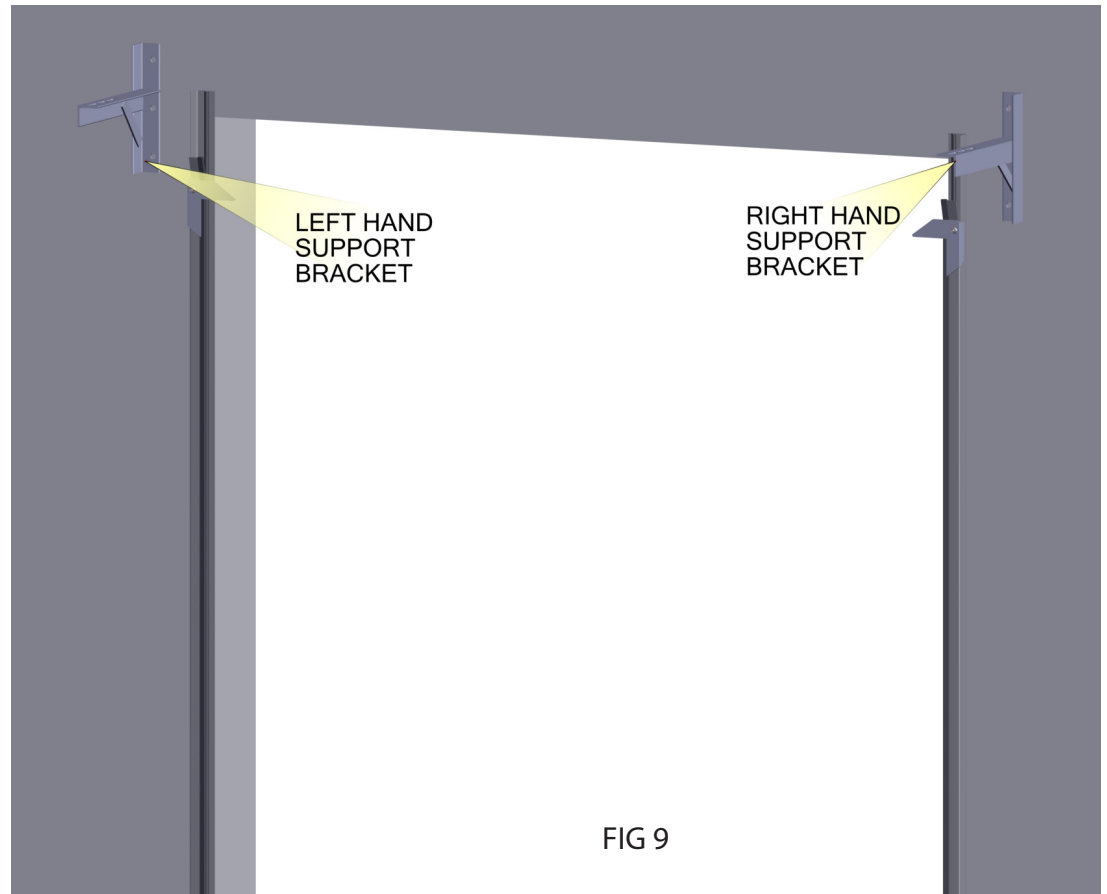

SECTION 5 - DOOR INSTALLATION

STEP 4 INSTALL DRIVE COMPONENTS

- There are four operation options.
 - Motor operator drive sprocket(40t #41 sprocket), see FIG 10A, FIG 10B, and FIG 10C.
 - Direct drive chain hoist, see FIG 10D.
 - Motor operator drive sprocket (72t #41 sprocket), see FIG 10E.
 - Reduced chain hoist, see FIG 10F.
- Assemble the sprocket, bearing, and the sprocket bracket together using 3/8" - 16 x 1" hex head bolts, 3/8" lock washers, 3/8" flat washers, and 3/8" - 16 hex nuts. See FIG 10A and FIG 10B.
- Position the assembly up against the drum wheel of the curtain assembly. Once the holes are aligned secure it using 3/8" - 16 x 1" hex head bolts, 3/8" lock washers, 3/8" flat washers, and 3/8" - 16 hex nuts. See FIG 10C.

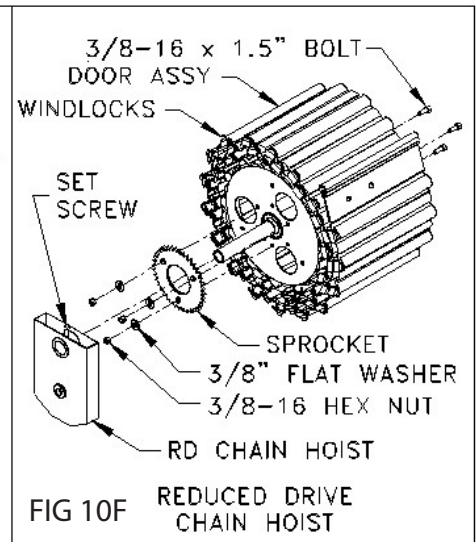
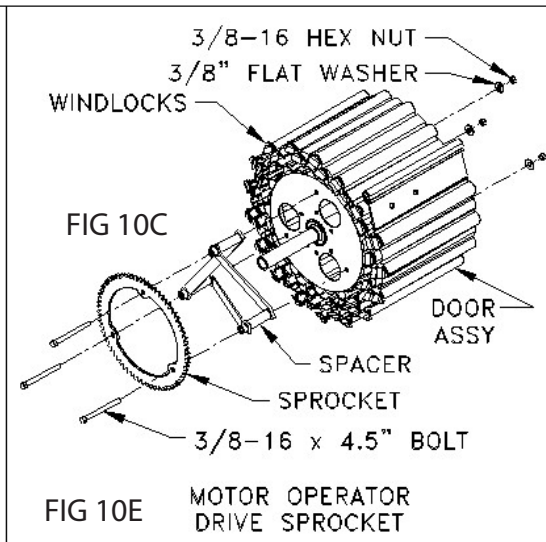
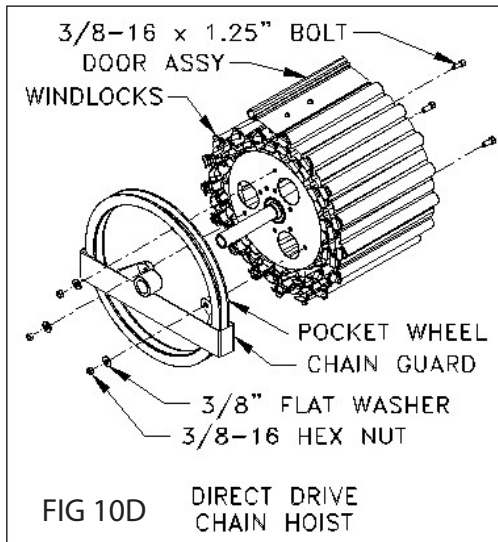
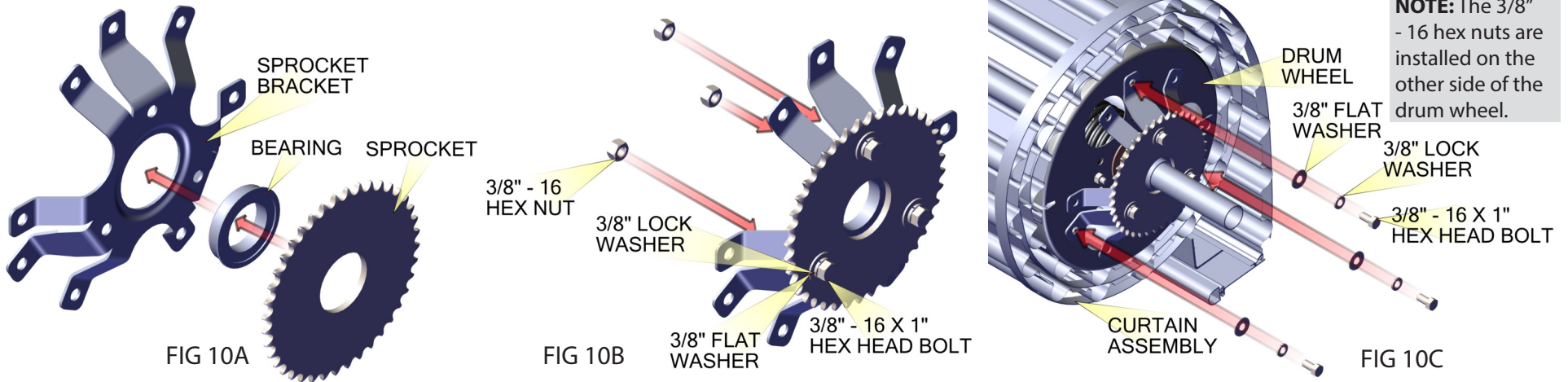

SECTION 5 - DOOR INSTALLATION

STEP 5 INSTALL TENSIONERS

After installing the brackets and drive components, install the axle tensioner devices.

- Identify which is the tensioner and tensioner support. See FIG. 12A.
- On the non-operator side of the curtain slide the tensioner device onto the axle. Ensure the arrow id is pointing towards the wall when the door is installed. See FIG. 12B.
- On the operator side of the curtain slide the tensioner support device onto the axle. Ensure the arrow id is pointing towards the wall when the door is installed. See FIG. 12B.

IMPORTANT: TENSION HOLDING ASSEMBLIES MUST BE ORIENTED CORRECTLY IN ORDER TO HOLD TENSION ON THE DOOR.

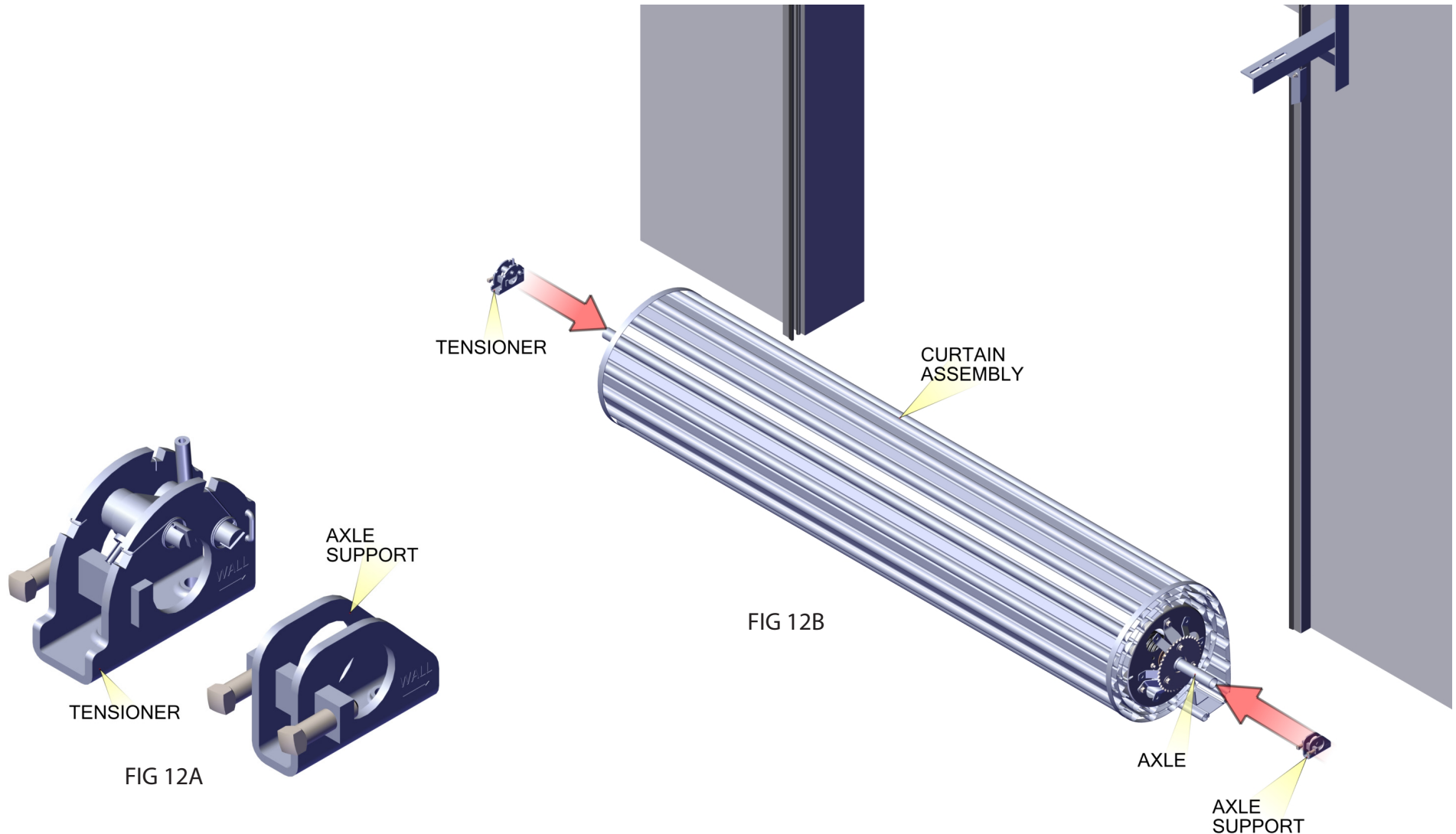

SECTION 5 - DOOR INSTALLATION

STEP 6 LIFTING THE CURTAIN ASSEMBLY AND SECURING TENSIONERS

⚠ WARNING

CURTAIN ASSEMBLY IS HEAVY. ALLOWING CURTAIN ASSEMBLY TO FALL WHILE LIFTING, COULD RESULT IN SEVERE OR FATAL INJURY.

⚠ WARNING

TO AVOID SEVERE OR FATAL INJURY, NEVER WALK, STAND, OR WORK BELOW CURTAIN ASSEMBLY BEFORE IT IS SECURED TO SUPPORT BRACKETS.

NOTE: The left hand end of the curtain assembly (when installed) will be the end with the spring.

- Lift the curtain assembly up to the support brackets.
- Align tensioner devices with the brackets so that when door is lowered down to the brackets, both devices will sit on top of the brackets.

NOTE: Be sure that the door is able to revolve without scraping against door header or guides.

- Rotate curtain assembly so that bottom bar angle is at the bottom of the curtain roll.
- Now, remove the cardboard packaging from the door.
- Ensure that the bottom bar angle is at the bottom of the curtain roll.
- Secure the tension devices to the brackets using (2) 3/8" - 16 x 1" hex head bolts, 3/8" lock washers, and 3/8" flat washers. Tighten bolts 1/2 turn past snug.

IMPORTANT: TENSIONERS MUST BE INSTALLED AS CLOSE TO HEADER AS POSSIBLE, PER STEP #5.

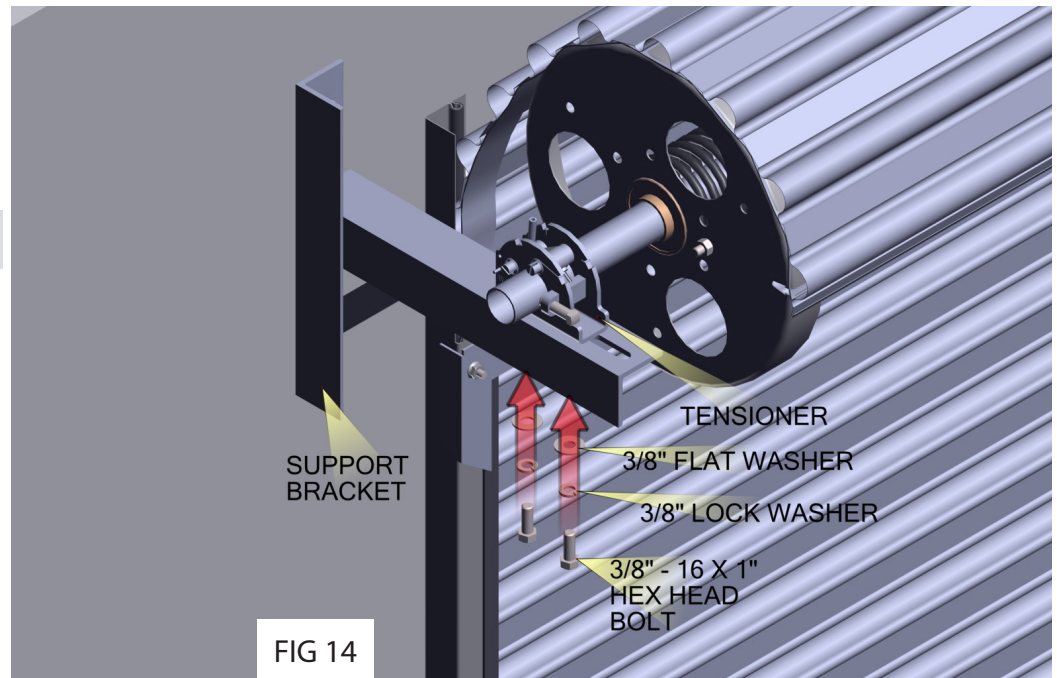
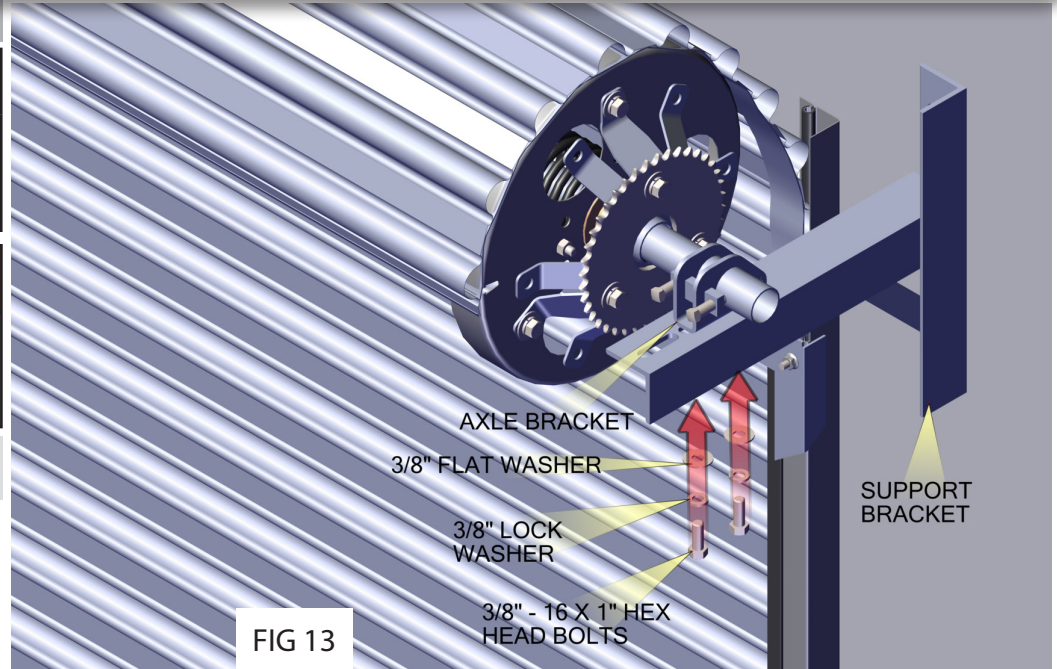

SECTION 5 - DOOR INSTALLATION

STEP 7 APPLY INITIAL TENSION TO THE DOOR SPRINGS

- Start with the bottom bar angle at the bottom of the curtain roll and use a pipe wrench to rotate the axle approximately to the turns indicated in the spring turns chart, shown below.
- The amount of tension required may vary slightly. Final adjustment, if necessary, will be made in Step #8.

IMPORTANT: TIGHTEN THE SET SCREWS ON BOTH TENSIONERS BEFORE OPERATING THE DOOR.

⚠ WARNING

ALWAYS STAND TO ONE SIDE OF WRENCH WHEN APPLYING TENSION, TO AVOID INJURY IF YOU LOSE CONTROL OF WRENCH.

- Cut the tape that holds the door in a roll and gently pull the curtain down into the guides on both sides until the bottom bar is below the bottom bar stops.
- Do not pry on the bottom bar stops to get bottom bar past, instead loosen fasteners until bottom bar angle easily clears stops.
- If the door has a tendency to close, secure in position using clamps.
- If the door has a tendency to rise, secure in position using a wood prop.
- While the door is secured from moving, tighten the bottom bar stop fasteners on both guide assemblies.

⚠ WARNING

SPRING TENSION CAN CAUSE CURTAIN ROLL TO ROTATE RAPIDLY. SECURELY HOLD CURTAIN ROLL FROM ROTATING WHILE APPLYING PRETENSION OR SERIOUS INJURY OR DEATH COULD RESULT.

Spring Turns Chart

Max Height		Max Width									
		5' 0" (60")	7' 0" (84")	8' 11" (107")	9' 11" (119")	10' 11" (131")	11' 11" (143")	12' 11" (155")	13' 11" (167")	14' 11" (179")	16' 0" (192")
16' 0"	192"	2	1-7/8	1-3/4	1-7/8	1-7/8	1-3/4	1-3/4	1-7/8	1-5/8	1-3/4
12' 0"	144"	2	2	1-5/8	1-5/8	1-5/8	1-3/4	1-5/8	1-3/4	1-5/8	1-3/4
10' 0"	120"	2	2	2-1/8	1-3/4	1-5/8	1-3/4	1-5/8	1-3/4	1-7/8	1-3/4
7' 6"	90"	2	1-3/8	1-7/8	1-5/8	1-3/4	1-7/8	1-3/4	1-3/4	1-3/4	1-5/8

SECTION 5 - DOOR INSTALLATION

STEP 8 LUBRICATING AND ADJUSTING THE GUIDES

- Lubricate the insides of guides with weather resistant lubricating spray. Move the door up and down to check for proper operation. Adjust the guides if necessary to allow for proper clearance and operation.

NOTE: If door is difficult to move up or down due to spring imbalance, continue on to STEP #7 and return to STEP #6 once springs are properly adjusted.

- Lower and raise the door to check the counterbalance. If the door lowers easily and raises hard, more spring tension is required. If the door lowers hard and raises easily, less spring tension is required. First, open the door fully and fasten vise grips to guides below bottom bar. Then, loosen the set screws on both tensioners.
- To remove tension, slightly pull down on the pipe wrench to unlock the tensioner. Then, pull and hold the small rod on the top of the tensioner to completely disengage the tensioner. Slowly release tension by allowing the wrench to rotate. Release the tensioner rod to lock the axle in place while re-adjusting the pipe wrench.
- Before operating the door, re-tighten the set screws on the tensioners. Remember to tighten all 3 square-headed locking bolts on the tensioner devices when finished to maintain desired adjustment. Remove vise grips after tightening locking bolts.
- Repeat the above procedure if further adjustments are required. Once all adjustments have been made and the door is operating properly, recheck all fasteners and bolted connections to ensure that they are in place and properly tightened. Verify that all set screws in the components installed in step #4 have been tightened.

⚠ WARNING

SECURELY HOLD DOOR CURTAIN UNTIL BOTTOM BAR STOP FASTENERS HAVE BEEN TIGHTENED. IF NOT SECURELY HELD, DOOR MAY RAISE OR DROP, POSSIBLY CAUSING INJURY OR DEATH.

⚠ WARNING

NEVER REMOVE BOTTOM BAR STOPS WHEN ADJUSTING TENSION, OTHERWISE, DOOR CAN SPIN UNCONTROLLABLY RESULTING IN SERIOUS INJURY OR DEATH.

⚠ WARNING

ONCE THE TENSIONER ROD IS DISENGAGED, HOLD WRENCH SECURELY. SPRINGS CAN CAUSE SERIOUS INJURY IF NOT CONTROLLED PROPERLY.

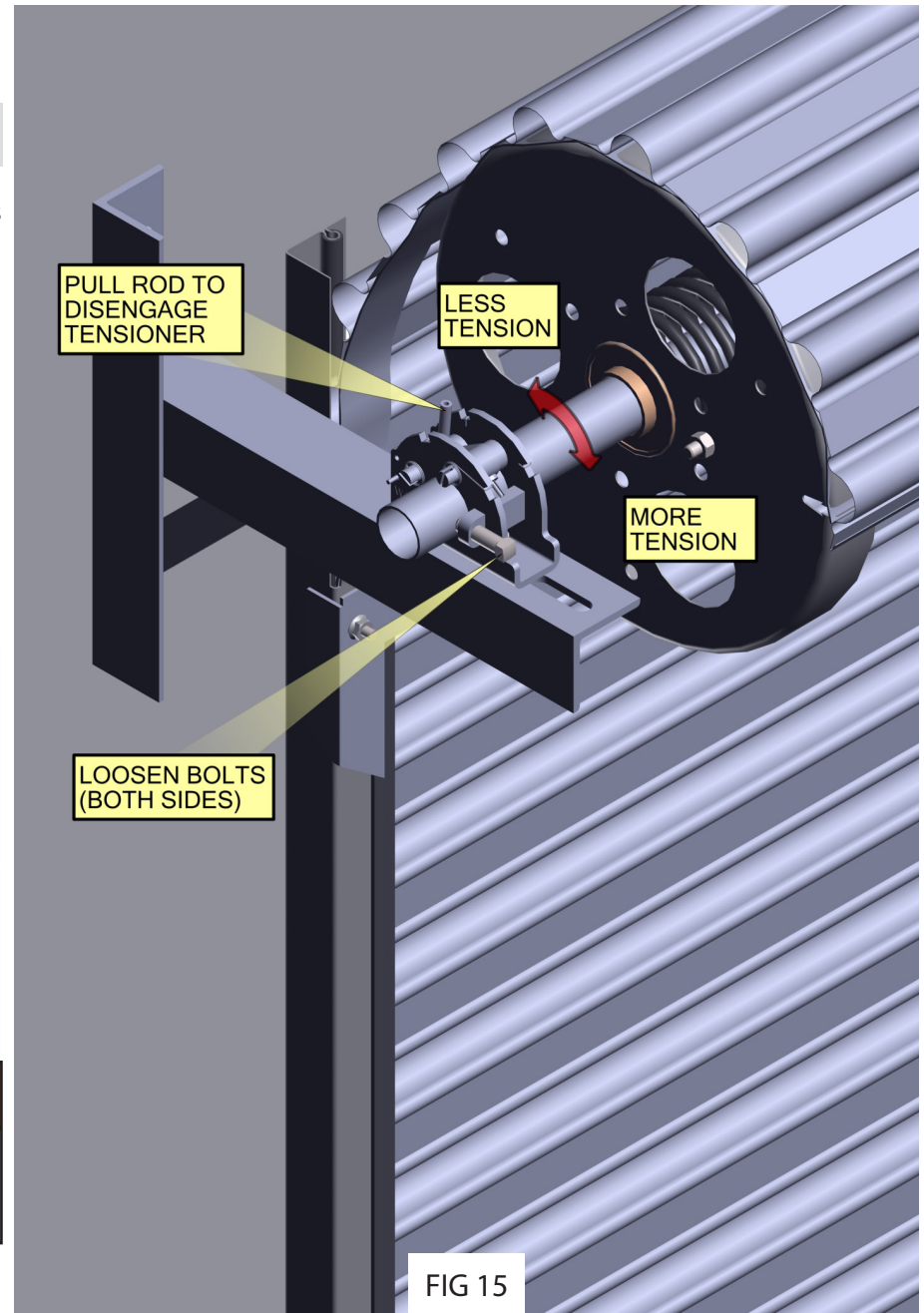

FIG 15

SECTION 5 - DOOR INSTALLATION

STEP 9 INSTALLING LIFT HANDLE, STOP CLIPS AND OPTIONAL SLIDE BOLT LOCKS

- Install a lift handle in the center of the bottom bar using 1/4"-20 x 5/8" carriage bolts and 1/4"-20 flange hex nuts, placed so the nut is on the coil side, or inside of door as shown. If the opening width is greater than 5 foot and the door does not have slide bolt locks, install a second lift handle on the right hand side of the bottom bar (outside looking in). See FIG 16.
- Install 1/4"-20 x 5/8" carriage bolts and 1/4"-20 flange hex nuts in all remaining bottom bar holes. See FIG 16.

For DS-75 Mini 'Z' Stop-Clip Attachment:

- Install the 'Z' stop-clip as shown on the right. Since the stop-clip has a retaining tab on top, it only requires one bolt to secure it to the bottom bar. Repeat assembly procedure for both sides. See FIG 17.

For DS-50 & 100 'C' Stop-Clip Attachment:

- For doors with an aluminum bottom bar, a 'C' stop-clip will need to be installed. Only one bolt is required to secure the stop-clip to the bottom bar when attaching a lift handle on that side. Repeat assembly procedure for both sides. See FIG 18.

For 'C' Stop-Clip w/ Inside Slide Bolt Attachment:

- Install slide bolt locks, if provided, as shown. The bottom bar will have (4) carriage bolts & flange nuts pre-attached. See FIG 19.
- Verify that the flat sides of the nuts are horizontal to the bottom bar. This ensures smooth operation of the slide bolt. Place the slide bolt lock so that the slot rides on the flange nuts. Then, add the stop-clip and attach, using the flanged nuts. See FIG 19.
- Repeat assembly procedure for both sides.

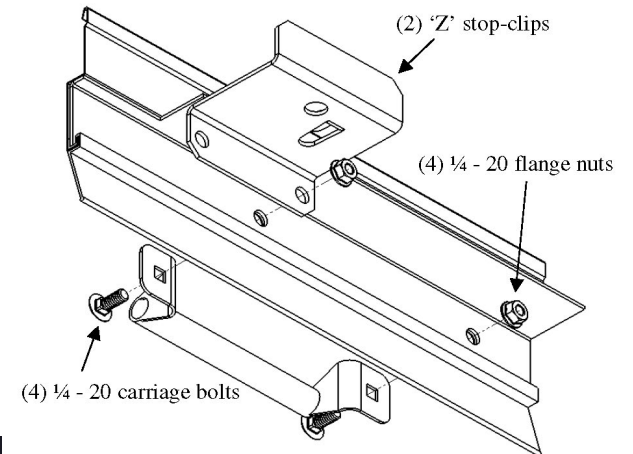
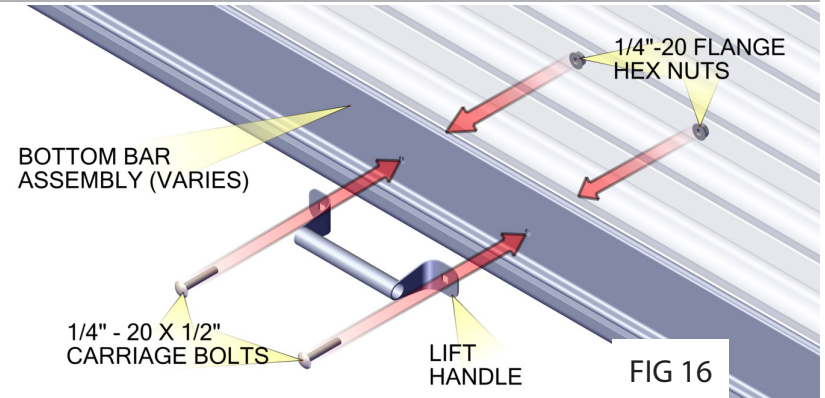

FIG 17

WARNING
FAILURE TO PROPERLY INSTALL STOP-CLIPS TO THE BOTTOM OF THE DOOR MAY RESULT IN SERIOUS INJURY OR DEATH.

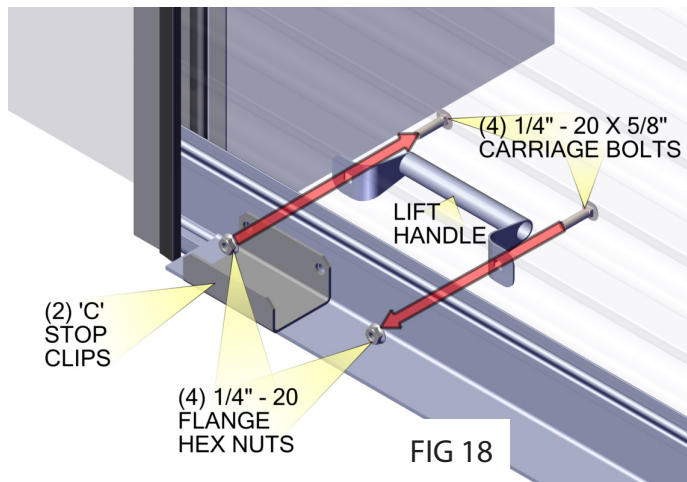

FIG 18

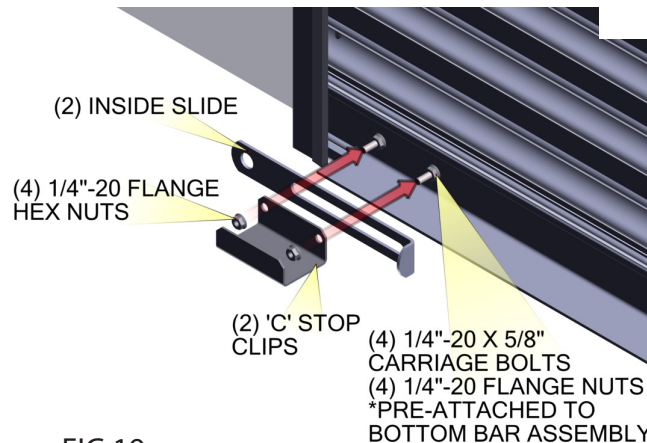

FIG 19

SECTION 5 - DOOR INSTALLATION

STEP 10 INSTALLING OPTIONAL TOP DRAFT

- Close the door and secure it in the down position.
- Use a pencil to mark the door panel corrugation that is parallel with the bottom of the header/lintel from the outside of the opening. If this corrugation protrudes below the header, mark the one just above.
- Open the door until the marked corrugation is accessible.
- Stretch the top draft stop across the door and attach it to the curtain on the marked corrugation with the self-drilling screws provided, locating the screws on 12" centers.
- Trim the top draft stop to clear the guides if required. When the door is closed, the draft-stop should seal on the header. See FIG 20 and FIG 21.

NOTE: Top draft stop may not seal on the header if not installed on a corrugation, as shown.

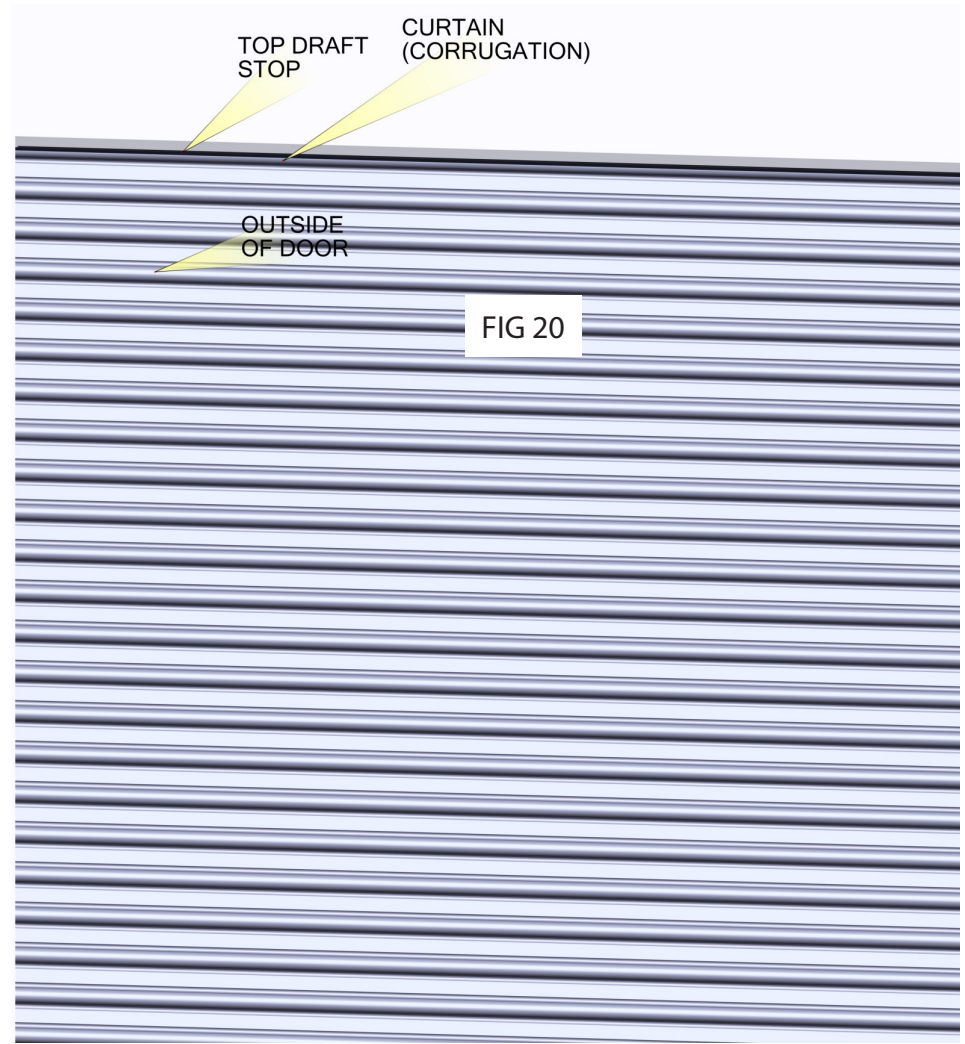
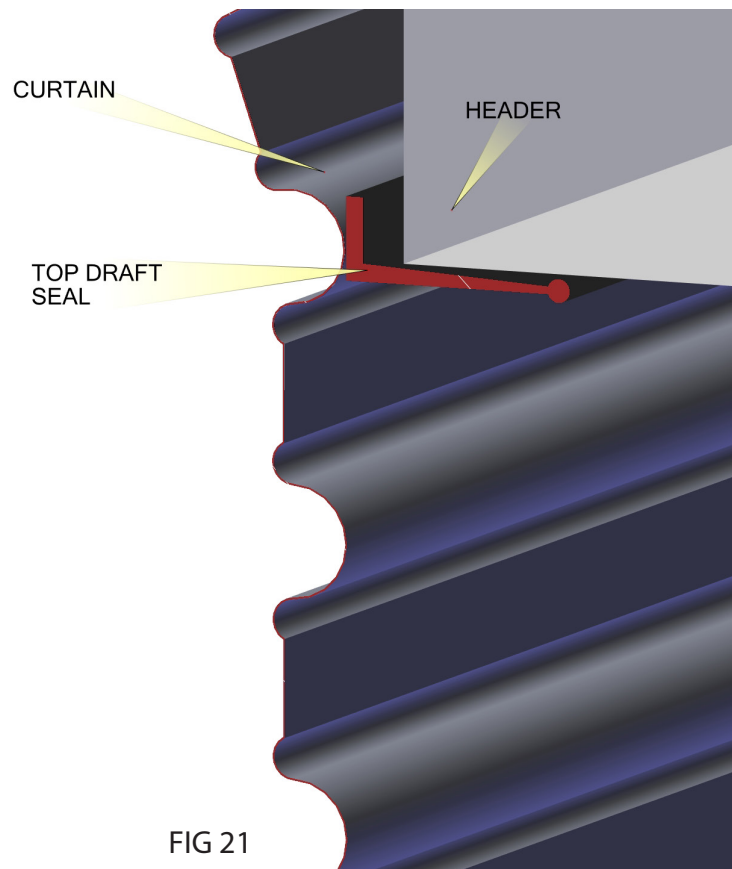

SECTION 5 - DOOR INSTALLATION

STEP 11 ALIGN THE SPROCKETS

- Feed the hand chain through the pocket wheel assembly (installed in step #4), around the cast iron hand chain wheel, and connect the two end links.
- Align the chain hoist so that the 41B9 sprocket on the pocket wheel assembly is in line with the 41A40 sprocket bolted to the barrel. Next, tighten the hoist-locking bolts to lock the pocket wheel assembly to the shaft to prevent it from shifting or rocking. See FIG 22 and FIG 23.

⚠ WARNING

HOIST LOCKING BOLTS MUST BE TIGHT TO ENSURE HOIST CANNOT SHIFT AND PERMIT ROLLER CHAIN TO COME OFF, THEREBY ALLOWING DOOR TO DROP POSSIBLY CAUSING SEVERE INJURY OR DEATH.

- Next, connect the #41 roller chain between the pocket wheel assembly sprocket and the barrel sprocket. Now run the door up and down several times to ensure that the roller chain does not come off. If it does, go back and check the alignment of the sprockets.

⚠ WARNING

KEEP LOOSE CLOTHING, FINGERS, HANDS, AND ARMS AWAY FROM ALL MOVING MECHANISMS AND PLACES WHERE CHAIN MEETS EITHER SPROCKET, OR SERIOUS INJURY OR DEATH COULD RESULT.

STEP 12 INSTALL THE CHAIN KEEPER

- Now install the hand chain keeper to the wall approximately four feet above the finished floor with the hardware provided. Refer to the figure in step #6 of this manual for an additional view. See FIG 22 and FIG 23.

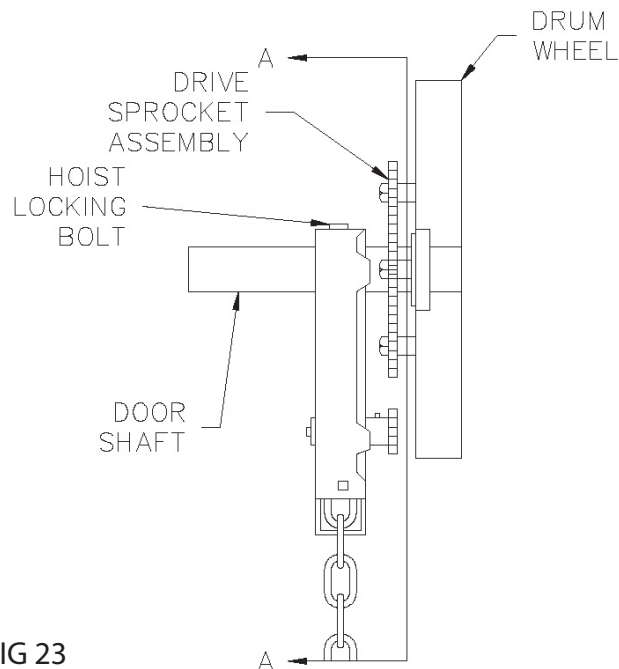

FIG 23

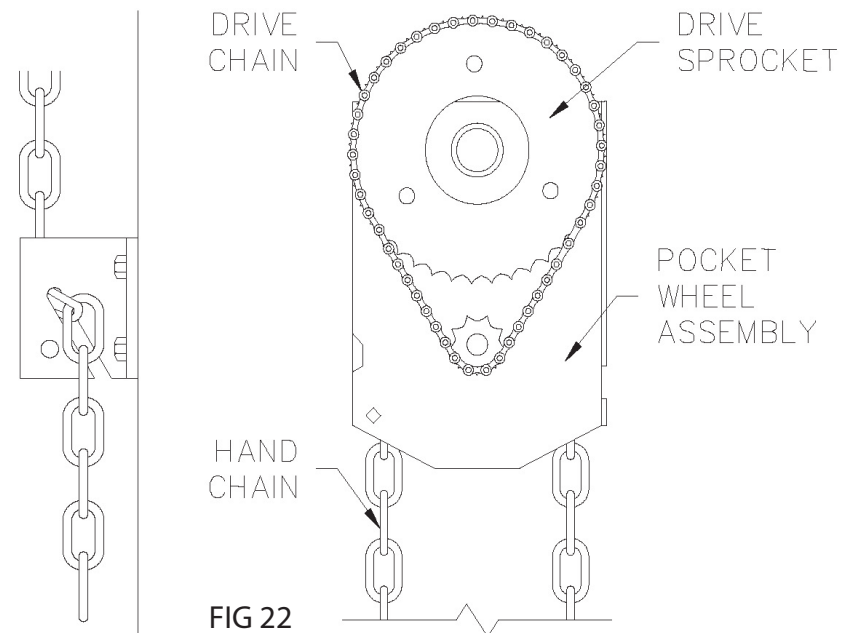

FIG 22



Roll-Up Sheet Door LIMITED WARRANTY

Wayne-Dalton
P.O. Box 67- Mt. Hope, Ohio 44660

The Manufacturer warrants the ROLL-UP SHEET DOOR and hardware fittings for a period of ONE YEAR from the time of delivery against any defects in workmanship or material. Manufacturer shall, upon notification, correct such nonconformity at its option, by repairing or replacing any defective part or parts.

NO EMPLOYEE, DISTRIBUTOR, OR REPRESENTATIVE IS AUTHORIZED TO CHANGE THE FOREGOING WARRANTIES IN ANY WAY OR GRANT ANY OTHER WARRANTY ON BEHALF OF MANUFACTURER.

The Manufacturer shall not be responsible for any damage resulting to or caused by its products by reason of installation, improper storage, unauthorized service, alteration of products, neglect or abuse, or attempt to use the products for other than the customary usage or for their intended purposes. The ROLL-UP SHEET DOOR warranty becomes null and void if other than Manufacturer's specified holes are drilled. The above warranty does not cover wear or any damage beyond Manufacturer's control or replacement labor.

THIS WARRANTY COVERS A COMMERCIAL PRODUCT, THE FOREGOING WARRANTIES ARE IN LIEU OF ALL OTHER WARRANTIES AND NO REPRESENTATIONS, GUARANTEES, OR WARRANTIES, EXPRESSED OR IMPLIED, (INCLUDING, BUT NOT LIMITED TO, THE WARRANTY OF MERCHANTABILITY OR FITNESS FOR PARTICULAR PURPOSE), ARE MADE BY MANUFACTURER IN CONNECTION WITH MANUFACTURE OR SALE OF ITS PRODUCTS.

Claims for defects in material and workmanship covered by this warranty shall be made in writing to the dealer from whom the product was purchased within the warranty period. Manufacturer may either send a service representative or have the product returned to the Manufacturer at Buyer's expense for inspection. If judged by Manufacturer to be defective in material or workmanship, the product will be replaced or repaired at the option of Manufacturer, free from all charges except authorized transportation and replacement labor.

THE REMEDIES OF BUYER SET FORTH HEREIN ARE EXCLUSIVE AND ARE IN LIEU OF ALL OTHER REMEDIES. THE LIABILITY OF MANUFACTURER, WHETHER IN CONTRACT, TORT, UNDER ANY WARRANTY, OR OTHERWISE, SHALL NOT EXTEND BEYOND ITS OBLIGATION TO REPAIR OR REPLACE, AT ITS OPTION, ANY PRODUCT OR PART FOUND BY MANUFACTURER TO BE DEFECTIVE IN MATERIAL OR WORKMANSHIP. MANUFACTURER SHALL NOT BE LIABLE FOR COST OF REMOVAL OR INSTALLATION OR SHALL NOT BE RESPONSIBLE FOR ANY DIRECT, INDIRECT, SPECIAL, OR CONSEQUENTIAL DAMAGES OF ANY NATURE.

This warranty gives you specific legal rights which may vary from state to state. However, some states do not allow limitations on how long an implied warranty lasts or the exclusion or limitation of incidental or consequential damages, so the above limitations or exclusions may not apply to you.



**Wayne-Dalton
Door & Systems Division
2589 County Road 168
Dundee, OH 44624
1-800-795-5095**