

# INSTALLATION INSTRUCTIONS VFD FOR HIGH SPEED METAL DOORS

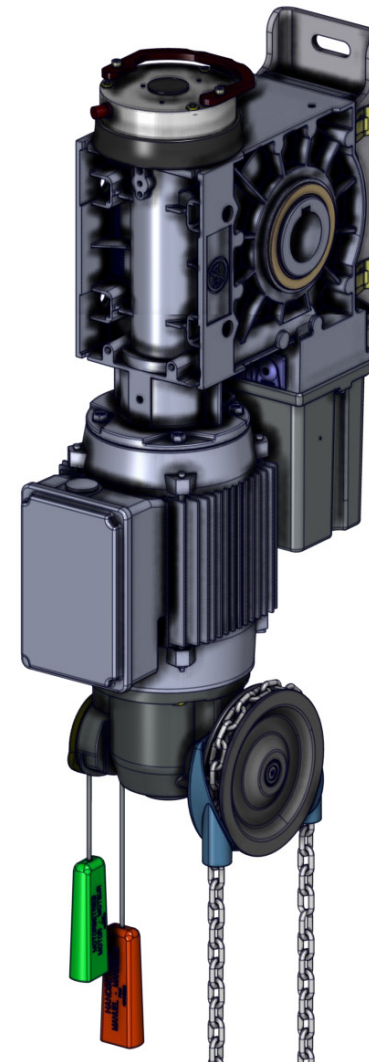

READ THESE INSTRUCTIONS THOROUGHLY BEFORE  
ATTEMPTING TO INSTALL THESE COMPONENTS!

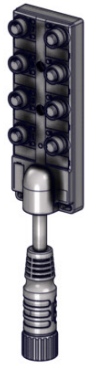

<b>TABLE OF CONTENTS</b>		
<b>SECTION</b>	<b>CONTENTS</b>	<b>PAGES</b>
1	SAFETY INFORMATION	3-4
2	COMPONENT IDENTIFICATION	5-8
3	HIGH VOLTAGE WIRING	9-10
4	INITIAL STARTUP PROCEDURE	11-12
5	MENUS	13-20
6	TROUBLESHOOTING THE CONTROLER	21-26
7	SERVICE AND MAINTENANCE	27
	APPENDIX A - CONTROL PANEL WIRE DETAIL	28
	APPENDIX B - OPTIONAL ACCESORY WIRING	29

# SECTION 1 - SAFETY INFORMATION

## OVERVIEW OF POTENTIAL HAZARDS READ THIS SAFETY INFORMATION

### **⚠ WARNING**



Service doors are large, heavy objects that move with the help of electric motors. Since moving objects and electric motors can cause injuries, your safety and the safety of others depends on you reading the information in this manual. If you have any questions or do NOT understand the information presented, call your nearest service representative.

In this section and those that follow, the words "**DANGER**", "**WARNING**", and "**CAUTION**" are used to stress important safety information. The word:

- ⚠ **DANGER** indicates an imminently hazardous situation which, if not avoided, will result in death or serious injury.
- ⚠ **WARNING** indicates a potentially hazardous situation which, if not avoided, could result in death or serious injury.
- ⚠ **CAUTION** indicates a potentially hazardous situation which, if not avoided, may result in injury or property damage.

The word **NOTE** is used to indicate important steps to be followed or important considerations.

1. Read manual and warnings carefully.
2. Keep the door in good working condition.
3. This door is equipped with a Light Curtain, check Light Curtain operation daily. Make any necessary repairs to keep it functional. Also check the function of any optional safety devices you have installed.
4. All models are equipped with an overcurrent device. This must be manually reset following an overcurrent condition.
5. Keep instructions in a prominent location near the Control Panel.

POTENTIAL HAZARD	EFFECT	PREVENTION
 <p><b>MOVING DOOR</b></p>	<p><b>⚠ WARNING</b> <b>Can Cause Serious Injury or Death</b></p>	<p><b>Do NOT</b> operate unless the doorway is in sight and free of obstructions. Keep people clear of opening while door is moving.</p> <p><b>Do NOT</b> change control to momentary contact unless an external reversing means is installed.</p> <p><b>Do NOT</b> operate a door that jamps.</p>
 <p><b>ELECTRICAL SHOCK</b></p>	<p><b>⚠ WARNING</b> <b>Can Cause Serious Injury or Death</b></p>	<p>Turn <b>OFF</b> electrical power before removing Control Panel or motor cover. When replacing Control Panel cover make sure wires are <b>NOT</b> pinched or near moving parts. Operator must be electrically grounded.</p>

# SECTION 1 - SAFETY INFORMATION

## Safety Instructions

### Electrical Power Requirements for all VFD systems

High Speed Metal Door systems are available in 3-phase. Voltages available are 240VAC, 480VAC, 575VAC, and 600VAC. **YOUR LOCAL CODES MAY REQUIRE THAT THE INCOMING POWER TO YOUR DOOR HAVE A LOCK-OUT / TAG-OUT EQUIPPED FUSED DISCONNECT SWITCH (TO BE FURNISHED BY OTHERS) WITHIN EYESIGHT OF THE DOOR'S CONTROL PANEL.** Incoming power wiring must meet all NEC and local building codes, plus be properly sized for the control panel's amperage rating on the nameplate. To reduce the risk of electric shock, the chassis of the control panel must be properly grounded.

### CAUTION

VFD controlled door systems must be supplied by a grounded voltage supply. Ungrounded voltage supply sources must be avoided. Unbalanced voltage supply systems should **NOT** be used. Voltage unbalance can cause deterioration of motor performance such as, loss of torque, overheating, decrease the winding insulation life and can cause motor starter contacts, located in the control panel, to permanently "weld" closed. Voltage unbalance can be caused by inadequate conductor sizing, improper transformer sizing, excessive single-phase loads, poor grounding or intermittent high resistance faults (faults which do not generate high enough fault currents to trip an over current protection device, but will cause the distributed capacitance in a supply system to shift). This shift may cause destructive over-voltages to occur. If an unbalanced supply must be used, it is strongly recommended that an isolation transformer or in-line reactor be installed. Consult a licensed electrician if there are any questions.

**Wayne Dalton's warranty will not cover damage caused by failure of the motor, control panel or other electrical components due to the use of an inadequately supplied or grounded system.**

# SECTION 2 - COMPONENT IDENTIFICATION

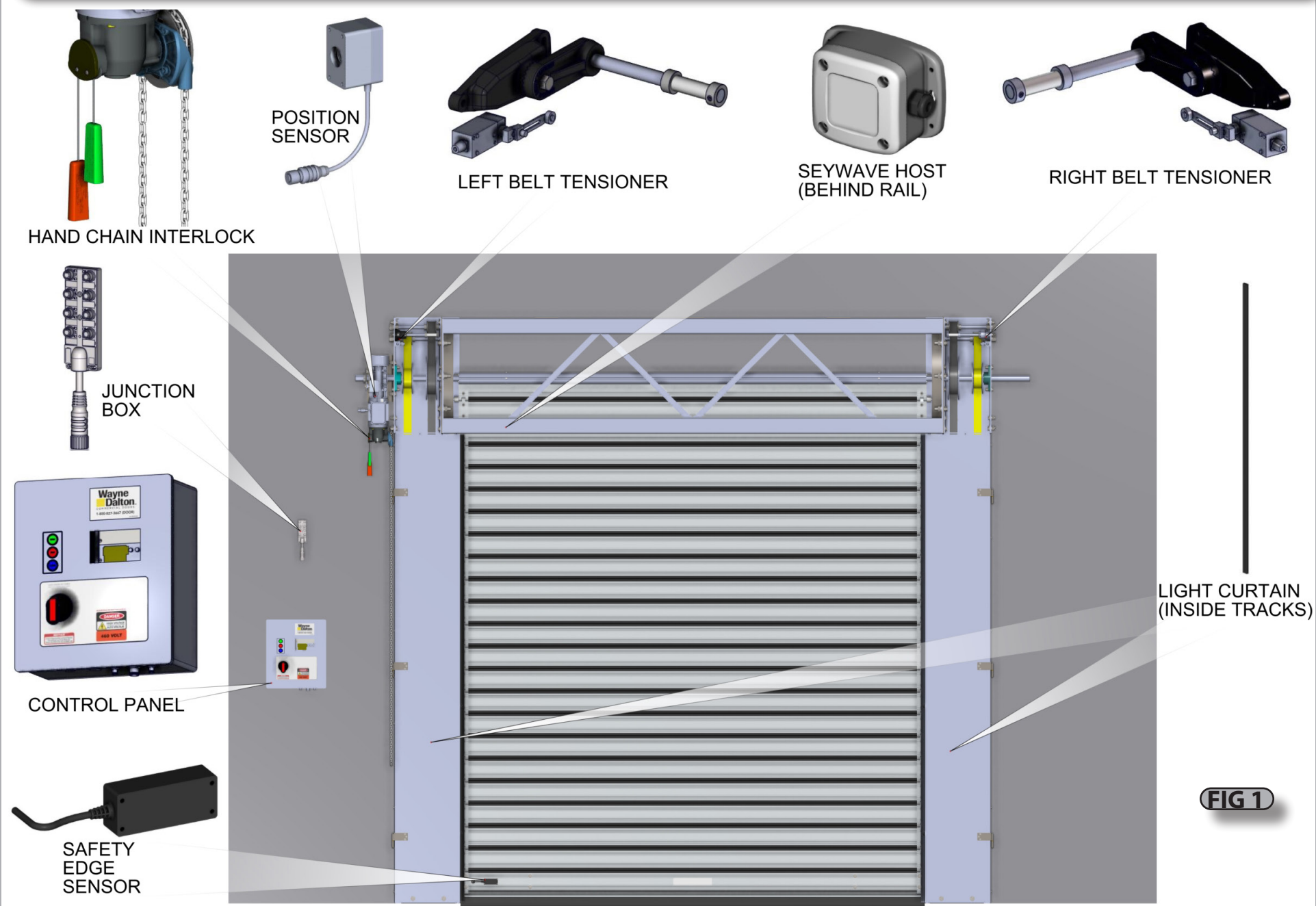

# SECTION 2 - COMPONENT IDENTIFICATION

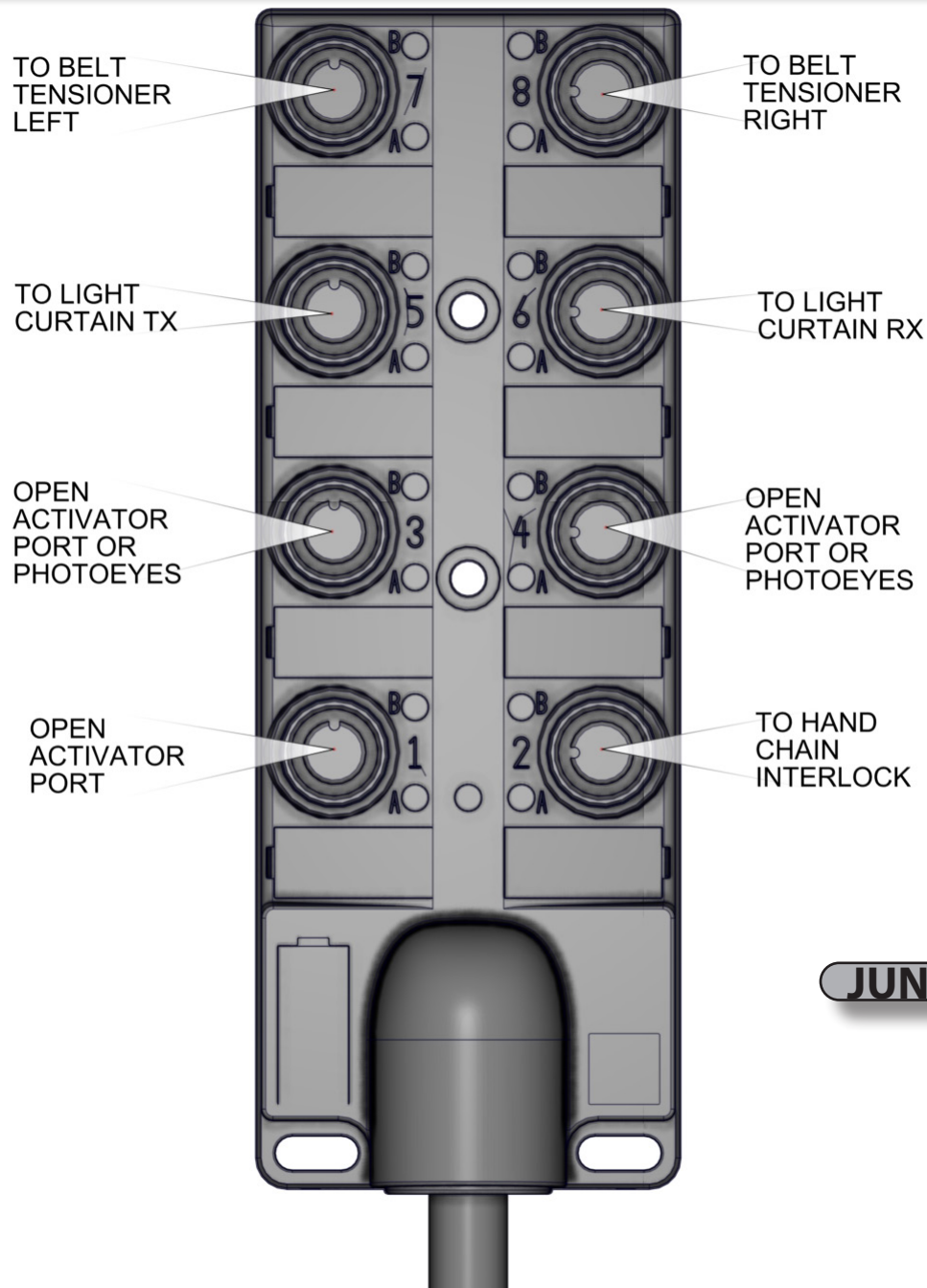

**JUNCTION BOX DETAIL**

**FIG 2**

# SECTION 2 - COMPONENT IDENTIFICATION

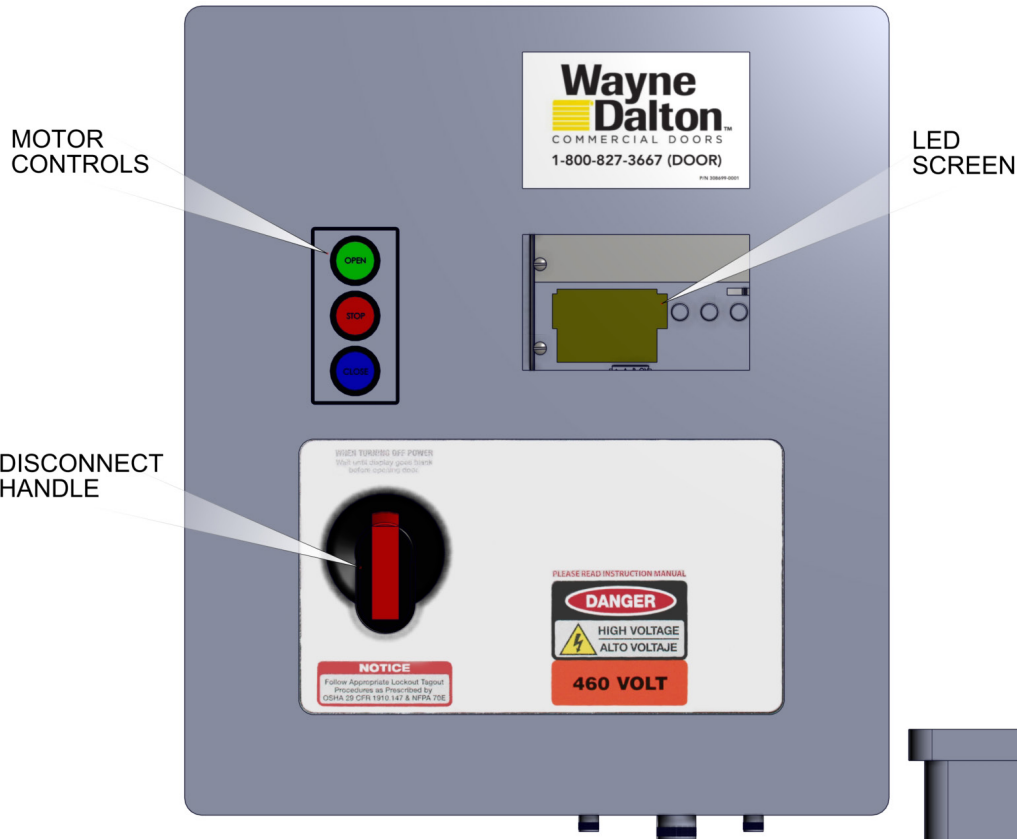

**FIG 3**

## CONTROL PANEL DETAIL



**FIG 4**

- MAIN POWER FROM DISCONNECT
- MOTOR CABLE
- TO SEYWAVE HOST
- 12 PIN JUNCTION BOX CABLE
- 5 PIN POSITION SENSOR CABLE

# SECTION 2 - COMPONENT IDENTIFICATION

## ⚠ WARNING

Before beginning this phase of the installation, ensure power supply is **DISCONNECTED** to avoid serious injury or death!

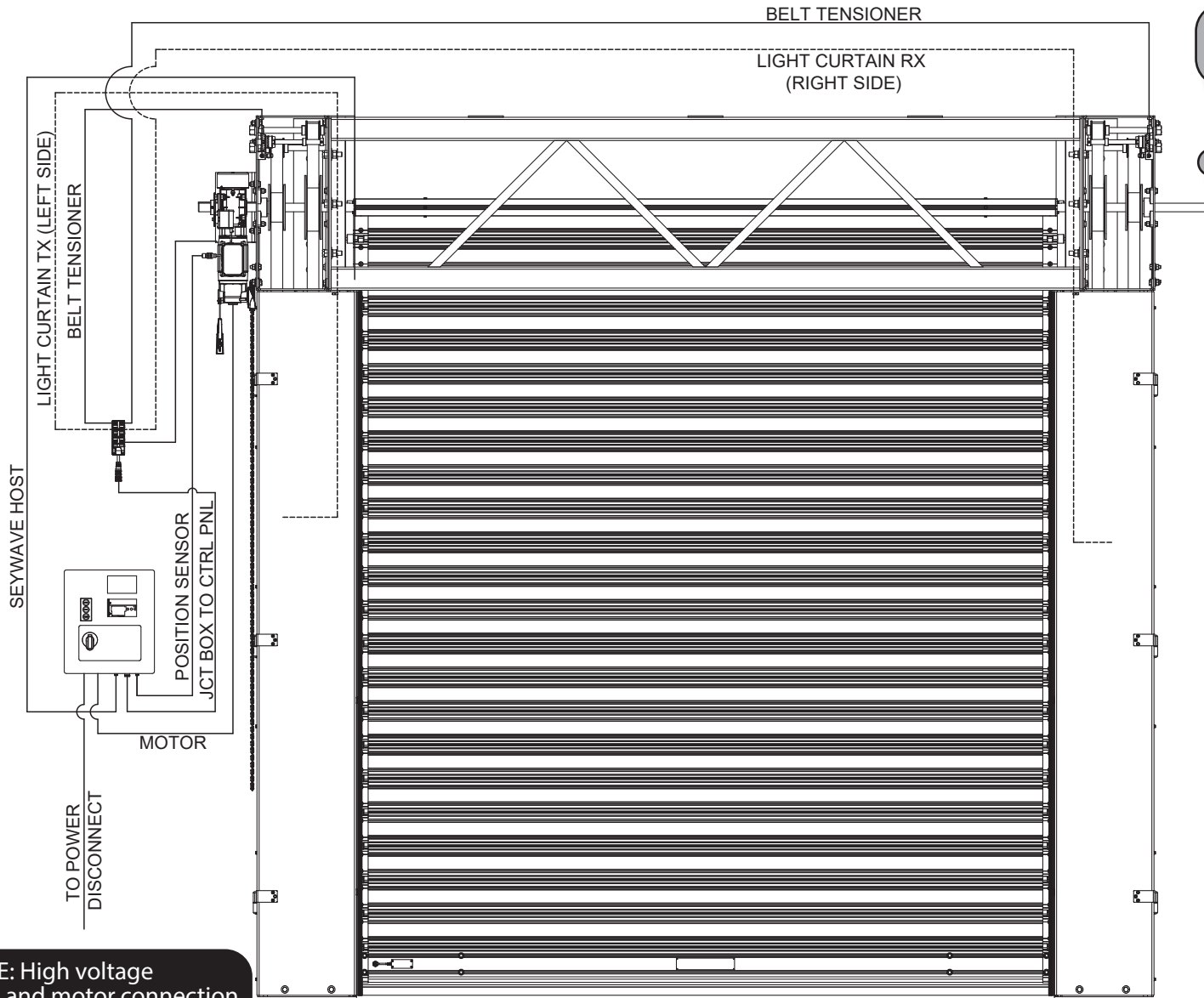

## WIRE ROUTING PLAN

FIG 5A



FIG 5B

NOTE: High voltage power and motor connection will be clearly illustrated in section 3.

NOTE: For wiring of optional accessories see appendix B.

## SECTION 3 - HIGH VOLTAGE WIRING

### **WARNING**

Before beginning this phase of the installation, ensure power supply is **DISCONNECTED** to avoid serious injury or death!

### **CAUTION**

VFD controlled door systems must be supplied by a grounded voltage supply. Ungrounded voltage supply sources should **NOT** be used. Voltage unbalance is a common occurrence on systems, which power both single phase and three phase loads, which can lead to unequal voltages on each phase leg. Voltage unbalance can cause deterioration of motor performance, such as loss of torque, overheating, decrease the winding insulation life, and can cause motor starter contacts, to permanently “weld” closed. Voltage unbalance can be caused by inadequate conductor sizing, transformer sizing, excessive single-phase loads, poor grounding, or intermittent high resistance faults (Faults which do NOT generate high enough fault currents to trip an Over Current Protection device, but will cause the distributed capacitance in an ungrounded three phase system to shift. This shift may cause destructive over-voltages to occur). Any single phase loads should be evenly distributed as much as possible between the 3 phases. Consult a licensed electrician if you have any questions.

**Wayne Dalton's warranty WILL NOT cover damage caused by failure of the motor, control panel or other electrical components due to the use of an inadequately grounded system.**

High Speed Metal Door systems are available in 3-phase. Voltages available are 240VAC, 480VAC, and 575VAC. **YOUR LOCAL CODES MAY REQUIRE THAT THE INCOMING POWER TO YOUR DOOR HAVE A LOCK-OUT / TAG-OUT EQUIPPED FUSED DISCONNECT SWITCH (TO BE FURNISHED BY OTHERS) WITHIN EYESIGHT OF THE DOOR'S CONTROL PANEL.** Incoming power wiring must meet all NEC and local building codes, plus be properly sized for the control panel's amperage rating on the nameplate. To reduce the risk of electric shock, the chassis of the control panel must be properly grounded. **208V Power is not recommended for this series of door.**

### **WARNING**

To avoid serious injury or death:

- It is recommended that line voltage wiring be performed by a qualified electrician.
- Be sure that electrical power has been disconnected from the input wires being connected to the operator prior to handling these wires. An appropriate lock-out/tag-out procedure is recommended.
- Line voltage must meet all local building codes.
- Make sure operator voltage, phase, and frequency ratings are identical to the job site line voltage ratings.
- Input power wiring must be properly sized for the operators amperage rating.

### **WARNING**

To avoid serious injury or death DO NOT calibrate motor or operate door unless doorway is in sight and free of obstructions. Keep clear of opening while door is moving.

# SECTION 3 - HIGH VOLTAGE WIRING

## **⚠ DANGER**

Before beginning this phase of installation, ensure **POWER SUPPLY** is disconnected to avoid serious injury or death!

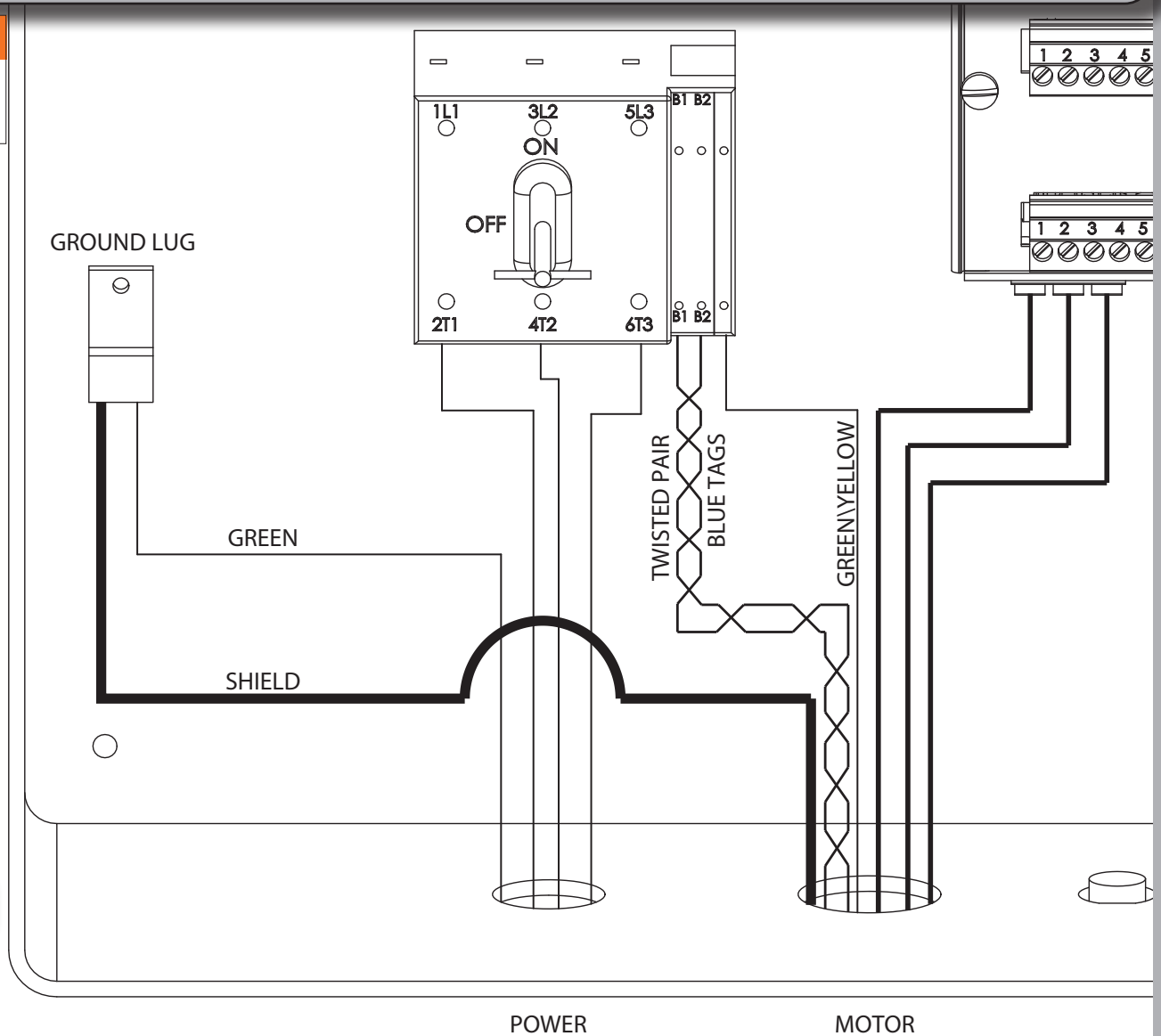

## **MOTOR AND POWER WIRING**

**FIG 6**

## **⚠ WARNING**

Use a NEMA 4X rated water tight fitting (not provided) on the incoming power wires. Failure to use a fitting could result in the risk of serious injury or death.

# SECTION 4 - INITIAL STARTUP PROCEDURE

## STEP 1 (APPLY POWER (LINE VOLTAGE))

After the wiring is complete and the door is closed turn the disconnect handle clockwise to the ON position in order to apply power to the Control Panel. A blue splash screen will pop up displaying the default profile, and controller data (consists of serial number, output capacity, software version, etc). Verify the system motor rating, and power ratings correspond with each other.

NOTE\* The system information can also be accessed in the SYSTEM STATUS > OVERVIEW menu. (see page 13-15)

## STEP 2 (INITIAL LIMIT SETUP)

The first time the controller is powered on, you must first set the limits. The LED screen will flash with the error E17, and you must reset the limits. This will also occur whenever the position sensor is disconnected from the controller. The position sensor, Light Curtain, sensing edge, and interlock switch must be connected before the limits can be set. If, for any reason, the limits cannot be set, please refer to troubleshooting section 6.

A. To enter the Menu, press and hold the OPEN, STOP, CLOSE membrane buttons for 3 seconds. A count down timer on the top left corner of the LED screen will display the remaining time left to hold. Refer to **Fig 5A** on page 13 for the complete menu structure.

B. Holding the Stop button for 1 second will go back up a level in the Menu. Continuing to hold the STOP button will continue to go back up the menu structure until the main screen.

C. Once in the main screen, a 25 second countdown timer will show on the upper left hand corner. This countdown timer displays how long until the OPEN/STOP/CLOSE buttons will no longer give access to the MENU. Once inside the menu, use the **OPEN button to scroll up**, **STOP button to enter**, and **CLOSE to scroll down**. Pressing OPEN/STOP/CLOSE immediately exits the counter.

Note: Instead of using the front panel buttons one can access the menu from the control unit using menu/enter, the ▲, and ▼ buttons.

1. Enter the Menus
2. Scroll down until you reach the LIMIT SETUP and hit enter.
3. Scroll down and enter into Quick Setup. A code request screen will appear. Enter the 3 digit pass code to gain access by scrolling up or down. Your pass code is located on a separate addendum.

NOTE: **Do not** display or freely give out the pass code.

4. Follow the prompts in order to set the open and close limits on the door. During this time, use the OPEN, CLOSE buttons to move the door. Again, the STOP button will be used as the ENTER function. If no error has occurred, it will then display QUICK SETUP DONE, otherwise if failed; QUICK SETUP ABORTED and it must be redone. Refer to Trouble shooting section 8 if required.

NOTE: Even if the door moves in the opposite direction, proceed with the steps in order. You will have the option to reverse polarity later.

NOTE: When setting the position, the position sensor count will be displayed. Verify the encoder count increases when the door is moving in the up direction, and does not roll over to the negative position.

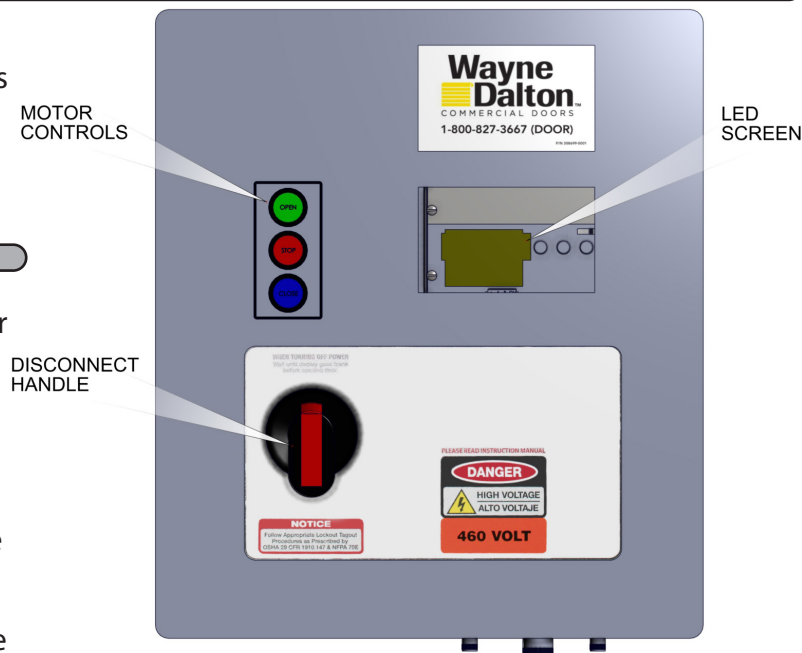

## SECTION 4 - INITIAL STARTUP PROCEDURE

### **⚠ WARNING**

All Entrapment Protection Devices are **OFF** in Emergency Jog and the Limits are **NOT SET**. Devices **OFF** while in Emergency Jog include: Edge Contact, Light Curtain, Photoeye, Wall push buttons, Radio Control, Limit Sensors, Loop Detector, or any motion sensor used as either an actuator or an Entrapment Protection Device. Only the Interlock remains active. Emergency Jog is the manual control for momentary operation of door via ARROW buttons on the membrane keypad or on the control unit.

**USE CAUTION WHILE SETTING UP THE DOOR IN THIS MODE, AND KEEP OPENINGS CLEAR OF PERSONS AND PROPERTY TO AVOID SERIOUS INJURY OR DEATH! Do NOT use Emergency Jog for general door operation.**

#### **STEP 3** PAIR THE WIRELESS SENSING EDGE HOST (SEYWAVE HOST)

The wireless sensing edge host must be paired with the controller.

1. Clear the Seywave Wireless Host by doing the following.
  - A. Remove the front cover.
  - B. Press and hold the Remote Pairing button until the Green LED lights up and hold for at least 5 seconds.
  - C. When the Green LED shuts off let go of the button.
  - D. The Green LED will turn on again for 1 second to show it successfully cleared all. Then it will show Red and Green LEDs flashing.
2. Pair the Seywave Wireless module on the bottom bar with the Seywave Wireless Host as follows.
  - A. Push and hold the "Pair" button on the wireless module on the bottom bar for approximately 10 seconds, the LED should come on and stay on until you let go.
  - B. Press the Pairing button on the Remote Host and apply momentary pressure. The green LED should light up and flash approximately once every second. This signifies Pairing Mode.
  - C. Squeeze safety edge to pair. You should see the host reset and the RED and Green LEDs will flash. If the pairing was unsuccessful you will see the Green LED flash until the 60-second timeout limit.

#### **STEP 4** VERIFICATION

Test each sensor to make sure the controller recognizes the fault.

- A. Light curtain -Obstruct the beam with a solid object. Light curtain should reverse the door's direction.
- B. Sensing Edge -Place a solid object, taller than 12", on the floor and close the door. Sensing edge should reverse the door's direction on contact with object.
- C. Interlock Switch -This is a constant activation sensor, release the hand chain from the switch, the door should stop and a fault display

NOTE: all faults and sensor activations are logged into the Fault Log. Access this through the menu SYSTEM STATUS > FAULT LOG in the Controller Menu. To clear faults hold the STOP button for 1 second once the fault has been fixed.

#### **STEP 5** SET SENSING EDGE SENSITIVITY

If you are in a high wind area you may need to adjust the sensitivity of the safety edge so that it does not trigger due to a high wind event.

- A. Enter the Menu
- B. Scroll down until you reach the SYSTEM CONFIG and hit enter.
- C. Scroll down and enter Options. Then select Seawave host pairing. Then select impact adjust and preset.
- D. Now make your sensitivity selection low, medium, or high.

# SECTION 5 - MENUS

## PART 1 EXPRESS MENU

The Express Menu is accessed by scrolling up, when at the idle screen or after exiting the menus. The express menu contains display options, timers, settings reset, and the emergency JOG. The timer functions in the Express Menu are shortcuts to timers in the system configuration menu without the need of a pass code.

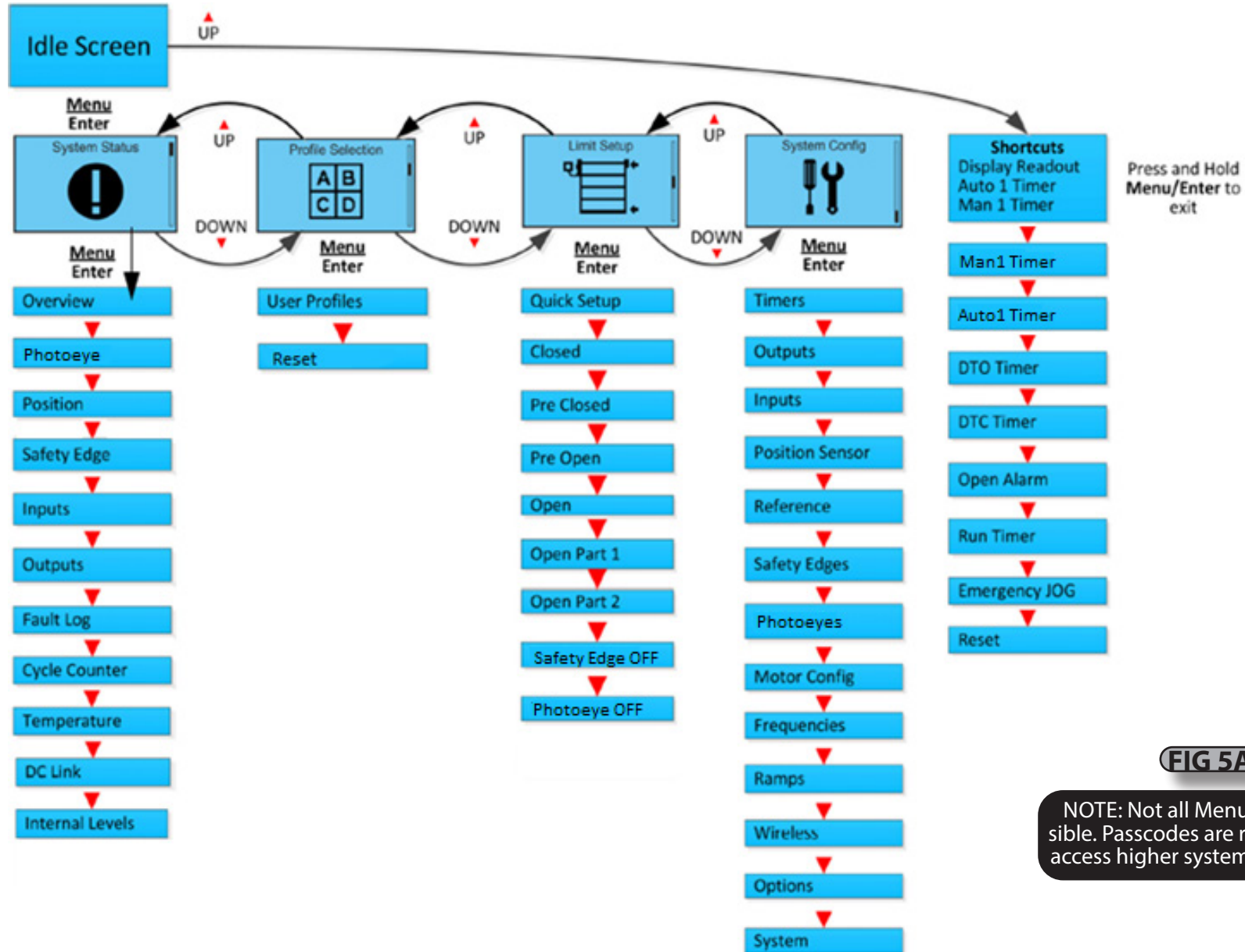

**FIG 5A**

NOTE: Not all Menus are accessible. Passcodes are required to access higher systems operations.

# SECTION 5 - MENUS

## PART 2 SYSTEM STATUS MENU

The System Status menu is read-only and provides parameter status displays for use in setup and troubleshooting. The options of the System Status menu are shown and described below. The controller is fully operational within this menu, allowing real-time parameter updates. To use the System Status menu:

- A. Enter the System Status menu
- B. Scroll down and highlight a menu option.
- C. Enter to view the highlighted option.
- D. Press and hold STOP or ENTER when finished to return to the System Status menu.
- E. Repeat to view other parameters if desired.

Overview	Overview displays status and current position of Photocell and Safety Edge (reversing edge)
Photocell 1: OK	1. To view status and current position of photocell
Safety Edge 1: OK	2. Safety Edge 2, scroll up.
Position: 123	

Position	Position shows the internal door position count. The battery level and status are shown
Position: 123	
Battery OK	

Inputs	Inputs provides an overview of the controller inputs. Box is marked if the corresponding controller input is active.
X2: <input checked="" type="checkbox"/> <input type="checkbox"/> <input type="checkbox"/> <input type="checkbox"/>	
X4: <input type="checkbox"/> <input type="checkbox"/> <input type="checkbox"/> <input type="checkbox"/> <input type="checkbox"/> <input type="checkbox"/> <input type="checkbox"/> <input type="checkbox"/>	

Outputs	Outputs provides an overview of the controller outputs. Box is marked if the corresponding controller output is active.
Relay: <input type="checkbox"/> <input type="checkbox"/> <input checked="" type="checkbox"/> <input type="checkbox"/>	
NPN: <input type="checkbox"/> <input checked="" type="checkbox"/>	

Log 1 of 10	Fault log displays error code and door operation cycle for the last 10 faults. Scroll up or down to navigate through the fault log.
Error: E10	
On Cycle: 045	

# SECTION 5 - MENUS

## PART 2 SYSTEM STATUS MENU (continued.....)



Cycle counter shows the number of operating cycles the door has completed (open/close = 1 cycle). Note: This is already shown by default at the top left corner in the main screen.

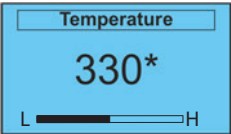

Temperature shows the internal temperature of the DGII Controller. This is a raw analog value and does not represent degrees centigrade or Fahrenheit. A display on the bottom graphically approximates either a Low or High temperature

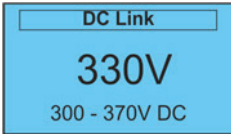

DC Link shows the internal DC Link voltage along with the acceptable range.

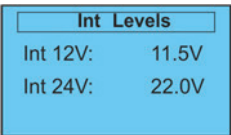

INT Levels shows the control's actual internal supply voltages.

## SECTION 5 - MENUS

### ⚠ CAUTION

To avoid potential equipment damage do not change the controllers profile unless advised to do so by your plant service technician. There are multiple profiles. You will need the correct one based on your particular door and motor configuration.

#### PART 3 PROFILE SELECTION MENU

The profile selection is done at the factory by default. Profiles can be selected based on the door the controller is operating. The profile is protected by a passcode, and can only be changed by Overhead Door service representative. All settings are lost and reverted back to defaults when the profile is changed. Profiles can be accessed through the main menu under Profile Selection.

#### PART 4 LIMIT SETUP MENU

Individual limits can be updated manually, however; the best option is to use the quick setup process as discussed earlier. The door will not be operational when setting limits. Limit settings are as described below.

### ⚠ WARNING

All Entrapment Protection Devices are **OFF** when setting limits. Devices **OFF** while setting Limits include: Edge Contact, Light Curtain, Photoeye, Wall push buttons, Radio Control, Limit Sensors, Loop Detector, or any motion sensor used as either an actuator or an Entrapment Protection Device. Only the Interlock remains active. **USE CAUTION! KEEP OPENINGS CLEAR OF PERSONS AND PROPERTY TO AVOID SERIOUS INJURY OR DEATH! Do NOT use for general door operation when setting limits.**

To configure the Limit Settings manually after using Quick Setup, select each individual position listed below from the Limit Setup menu, then move the door to the desired position. Store the position by pressing STOP or ENTER when finished. The display shows Stored and returns to the previous menu.

- Closed: Door fully closed.
- Pre Closed: Position where door changes to pre-closing speed during close.
- Pre Open: Position where door changes to pre-open speed during open.
- Open: Door fully closed.
- Open Part 1: Partially open position 1. Door opens to this position when a part 1 open input is active. (default: 75% of door open limit)
- Open Part 2: Partially open position 2. Door opens to this position when a part 2 open input is active. (default: 50% of door open limit)
- Rev. Edge OFF: Sets door position where safety edge check is turned off: the limit where the reversing safety edge should be ignored.
- Photocell Off: Sets door position where photocell should be ignored.

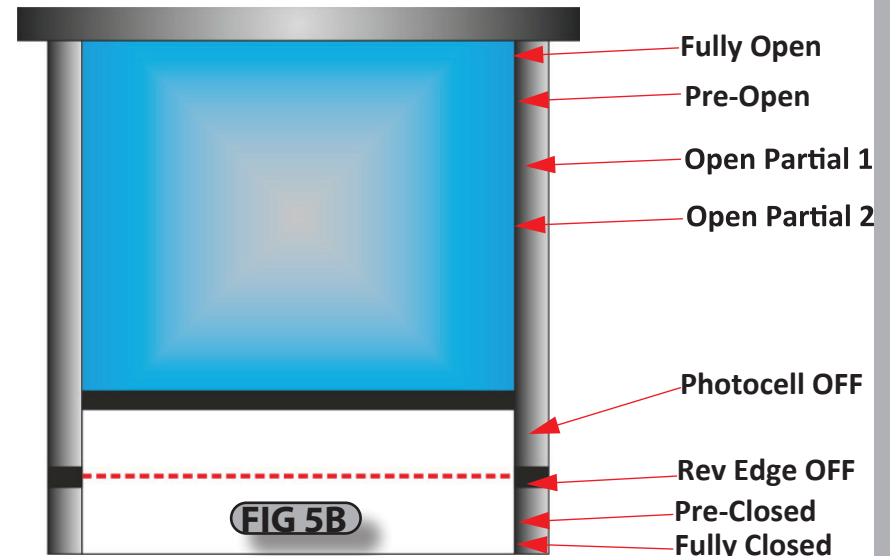

# SECTION 5 - MENUS

## PART 5 SYSTEM CONFIGURATION MENU

This menu contains all editable parameters on the door system. A passcode is required in order to change the settings. The door will not operate when inside the menu.

### A. Timers

1. Contains all the same timers in the Express Menu.
2. Setting the timer to 0 disables the timer.

B. Outputs - Configurable relay activation based on custom door status/events. Table on page 40 lists all available status/events.

C. Inputs - Inputs with configurable actuator functions. Table on pages 31-32 list all functions available with each input.

D. Position sensor -Do not update/menu is not used

E. Reference -Do not update/menu is not used.

F. Safety Edges -Do not update / Menu not used.

G. Photoeyes -Do not update/menu is not used

H. Motor Configuration - Do not update / Engineering use only.

I. Frequencies - Do not update / Tech Services use only.

J. Ramps - Do not update / Tech Services use only.

K. DG-XNET -Do not update / Menu not used.

L. Options -Menu to access the pairing of the wireless sensing edge host.

M. System -Do not update / Engineering use only.

### CONFIGURATION INPUT/OUTPUTS

A. Inputs. There are 3 parameters that can be set. Refer to **FIG 5C** (close up view of Input relays)

1. Function -A list of functions can be selected to determine how the input should operate the door.
2. Name -a name can be applied to the specific function
3. Logic -The logic for activation of the door can be chosen. Either Normally Open (0VDC ->24VDC) or Normally Closed (24VDC ->0VDC).

B. Outputs. Refer to **FIG 5D** (close up view of Output relays)

- 1 Function -list of functions can be selected to activate the output relay
2. The output is dependent on the input wired into the relay pins 2, 5, 7, 9.
3. Output relays 1 & 2 consist of two relay outputs, a NO and NC. Output Relays 3 & 4 contain only NO relay activation.

# SECTION 5 - MENUS

## PART 5 SYSTEM CONFIGURATION MENU (continued....)

INPUT SIGNAL	ACTIVATION DESCRIPTION
Manual	Momentary activation opens door unless the door is already at an open position. In this case, the door will close. 1) If the Manual timer is set to a value greater than zero, the controller delays closing of the door until the timer expires.
Open	Opens the door to fully open position when activated.
Auto 1	Momentary activation opens door to the fully open position limit. Upon deactivation the controller delays the door for the duration of the Auto timer. If reactivated during this time delay, the timer will be reset and will begin to decrement when the input is again deactivated. Upon expiration of the timer, the controller closes the door to fully closed position. If timer is not used, the door will stay in the open position when activated.
Stop	Momentary activation stops the motion of the door. This input uses the Stop Deceleration Ramp set under the System Config menu. <b>This input is also used to clear certain error conditions.</b>
Close	Closes the door to fully open position when activated
Emergency Stop	Activation immediately halts the door in motion. <b>This input uses the Emergency Deceleration Ramp set under the System Config menu.</b>
Safety Edge	Activation during a closing cycle stops the door and then reverses the door motion back to the fully open position limit. An "E10 Safety Edge Activated" error occurs.
Light Curtain	Activation during a closing cycle stops the door and then reverses the door motion back to the fully open position limit.
Lock Open	Activation causes the controller to hold the door at the fully open position limit. The input must be continuously activated to maintain the locked open state. Deactivating this input unlocks the door and allows normal operation.
Lock Close	Activation causes the controller to hold the door at the fully closed position limit. The input must be continuously activated to maintain the locked open state. Deactivating this input unlocks the door and allows normal operation.
Open Jog	Activation of this input moves the door in the direction of the fully open limit at Jog speed. Deactivating this input stops the door in motion. Activation during closing does not open or stop the door.
Close Jog	Activation of this input moves the door in the direction of the fully closed limit at Jog speed. Deactivating this input stops the door in motion. Activation during opening does not close or stop the door.
Breakaway	Activation halts door motion.
Open Position 1	Activation opens the door to the partial open 1 position limit. If activated during closing, door will reverse to 1 position limit.
Open Position 2	Activation opens the door to the partial open 2 position limit. If activated during closing, door will reverse to 2 position limit.
Open Part 1 Auto	Activation opens the door to partial open 1 position limit. The controller then delays the door for the duration of the Auto Timer. Upon expiration of the timer, the door closes fully.
Open Part 2 Auto	Activation opens the door to partial open 2 position limit. The controller then delays the door for the duration of the Auto Timer. Upon expiration of the timer, the door closes fully.
Flip Flop	Activation reverses the door operation. If door is closed, activation opens the door and vice versa. When door is closing and activated, the door reverses and begins opening and vice versa.
Man Part 1	Activation opens the door to the partial open 1 position limit, if not already at this position. If the door is already at this position, the door closes.
Man Part 2	Activation opens the door to the partial open 2 position limit, if not already at this position. If the door is already at this position, the door closes.

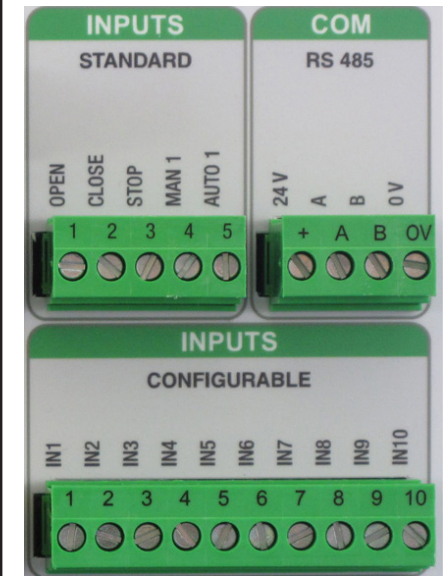

**FIG 5C**

# SECTION 5 - MENUS

## PART 5 SYSTEM CONFIGURATION MENU (continued....)

INPUT SIGNAL	ACTIVATION DESCRIPTION
Door Moving	Output is active when the door is in motion.
Door Not Moving	Output is active when the door is not in motion.
Door Open	Output is active when the door is at the fully open position.
Door Closed	Output is active when the door is at the fully closed position.
Door Not Closed	Output is active when the door is above the fully closed position.
Door Open Partial	Output is active when the door is at open part 1 position.
Door Opening	Output is active when the door is moving in the open direction.
Door Closing	Output is active when the door is moving in the close direction.
Delay to Close	Output is active when the Delay To Close timer is greater than zero and the door is commanded to close. The output remains active for the duration of the Delay To Close timer.
Delay to Open	Output is active when the Delay To Open timer is greater than zero and the door is commanded to open. The Open button must remain active until the Delay To Open timer has expired, the output will be active during this time. Upon expiration of the timer, the door opens and the output is deactivated.
Auto Close Active	Output is active for the duration of the Auto or Man timer during an auto close sequence.
System Error	Output is active when DGII is in any error condition.
Pre Warning Active	Output is active for the duration of the Auto Timer <b>and</b> during any close sequence.
Open Alarm Active	Output is active when Open Alarm Timer is greater then zero.

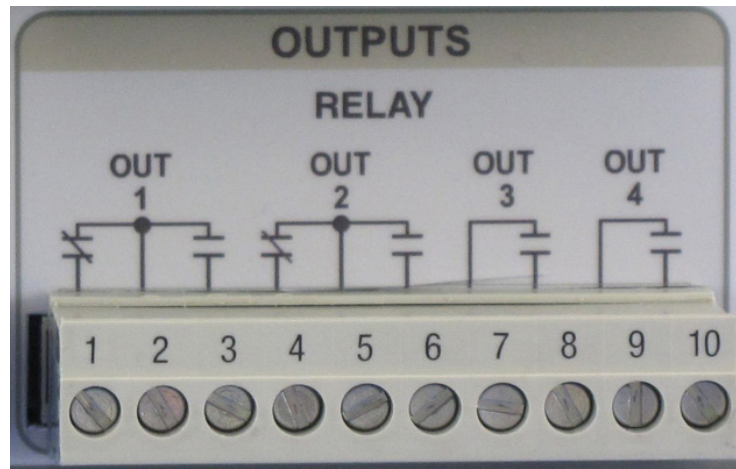

FIG 5D

# SECTION 5 - MENUS

## PART 6 INFORMATION MENU

How to use the keypad to retrieve operation events, fault/shutdown messages, and system status (Also see Section 8—Troubleshooting)

- A. With the unit idle enter the System Status menu.
- B. Scroll through the list of choices until you reach the Fault Log menu and enter.
- C. Scroll through the list until you reach the information you're looking for.
- D. When finished exit the menus and return to the main screen.

**NOTE:** The items in the Fault Log are listed in reverse chronological order with number 1 being the most recent and the highest number being the oldest.

- If NO keys are pressed for 120 seconds, display will exit back to the main menu.
- Motion can occur and panel responds normally to inputs while in the System Status Menus.

### FAULT LOG

Log 1 of 10

Error: E10

On Cycle: 045

## PART 7 SETUP CHECK LIST

### **⚠ WARNING**

Check ALL items below to ensure that the Control Panel is installed and operating properly and entrapment protection is working properly. A door system that is not properly setup can cause death or serious injury.

#### **CHECK**

- The door operates using all installed control devices.
- The door runs to its full open and full closed positions.
- The Entrapment Protection Device(s) will reverse a closing door when actuated.
- The proper Actuator selections are made to activate timers.
- The Hand Chain interlock switch prevents motor/door movement when the hand chain is pulled.

If the panel is in a location where public access is possible, install a means to limit access to the inside of the panel.

# SECTION 6 - TROUBLESHOOTING THE CONTROLLER

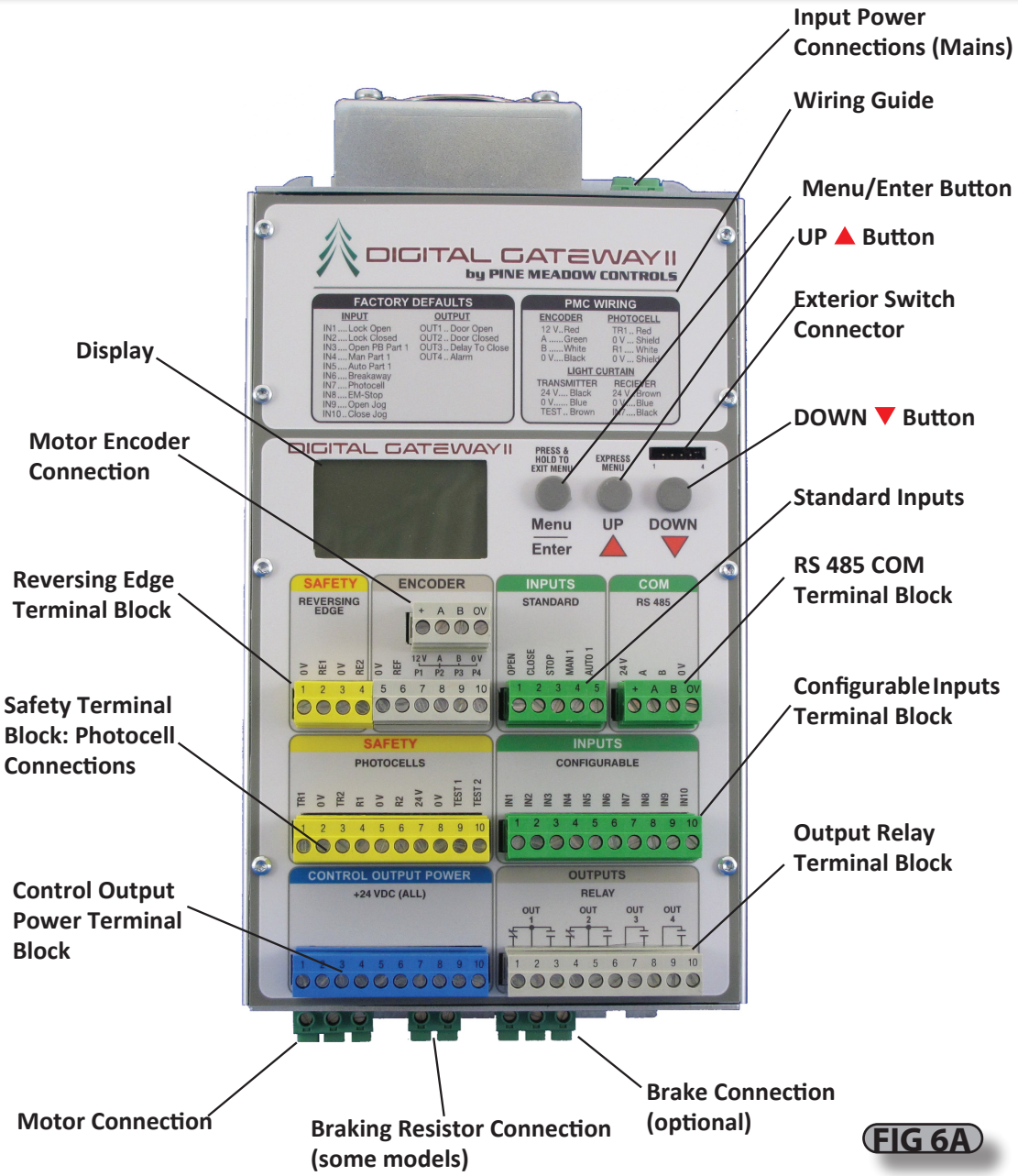

**FIG 6A**

# SECTION 6 - TROUBLESHOOTING THE CONTROLLER

## PART 1 GENERAL TROUBLESHOOTING

TROUBLE	POTENTIAL CAUSE	NOTES / CORRECTIVE ACTION
Door will not move	Door may be in Shut Down mode. Fix issue.	Press stop key to clear fault.
	No power	Check motor wiring, power line, system rating.
Timed Close not functioning	Timer is set to 0.	Verify or update specific timer in express menu..
	Timer condition not met.	Verify door is at open close limits, or condition is met.
Auto 1/ Manual 1 Function not working	Wiring or connection loose, signal not reaching controller.	Verify connections.
	Auto 1/Man 1 not selected as function.	Verify chosen input function.
On key release, door stops or reverses	One of the sensor inputs activated.	Verify sensor inputs.
Timed Close quits after a few reverses	After a factory set number of failed attempts, usually three, the door will stop attempting to Time Close after a reversal. This is normal door function.	Door will reverse a Timed Closed door without counting the first reversal as a failed attempt. NOTE: If Entrapment Prevention Inputs cause reversals in the meantime, the reversals will continue to count as failed attempts and stop the close timer after three tries.
Wall push button not responding.	Wiring and firmware setting incorrect.	Common should be set to 24V Stop is set to NC in firmware (System config > Inputs) Open is set to NO. Close is set to NO. Refer to <b>Fig 6B</b> page 23
General service Due: XXXXX	Routine service interval has elapsed.	Contact distributor for required maintenance.
Major service Req'd XXXXX	Required maintenance interval has elapsed.	Contact distributor for required maintenance.
Door stops for no reason, or acts differently than before - No errors displayed, only shows IDLE at status	A brownout or short has affected the controller	Use the disconnect switch to turn off the power, wait until the unit shuts off, then turn it back on (hard reset). -Contact customer service if it is still an issue.
	Possible overheat	Check fault log
One of the options to the Junction Box does not operate as expected	Connection to the Junction Box is incorrect	Ensure the Junction Box connections are correct (Via Manual) 1. Radio Remote Receiver is wired to Manual1 input -A 10 kohm load is also needed to be wired from the Manual1 input to a 24VDC connection (part of the kit when delivered). 2. Loop Detector or Motion Detector is wired to Option 1 (or to an Auto1 input) NOTE* Both can be wired, but one needs to be wired directly to the Control Unit (regular wire can be used)
Quick setup aborted	Fault occurred when setting limits	1. Fix faults in system. 2. Make sure Position Sensor does not roll over from +32,000 to -32,000 when setting limits. 3. Make sure Position count increases when setting door to open limit (door direction incorrect). 4. Restart Quick Setup.
Door limits have shifted	Position Sensor fault/failure	1. Verify Position Sensor connections. 2. Verify magnet in position sensor has not moved and has not rubbed against the encoder. 3. Reset limits.

# SECTION 6 - TROUBLESHOOTING THE CONTROLLER

## PART 2 CONTROL PANEL STATUS MESSAGES

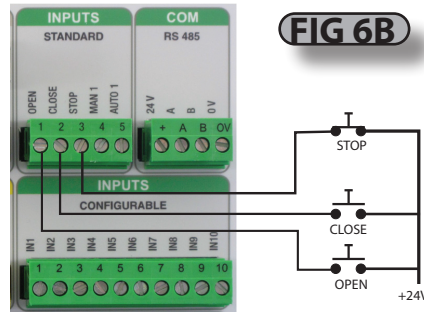

MESSAGE DISPLAYED	CAUSE	NOTES / CORRECTIVE ACTION
-----	Displayed if no message code is present in the Event or Error Log.	Contact service representative.
<b>STATUS</b>		
Idle	Door at rest, not at open, close, mid limits.	Displayed when door is motionless in Idle and not at open, close, open P1 limits. Door stopped using the STOP key.
<b>STATUS</b>		
Count down	Door at rest and counting down to timed close or open.	Time remaining in seconds is displayed.
<b>STATUS - OPENING</b>		
Opening	Door opening.	Displayed while door is opening from activation.
<b>STATUS - CLOSING</b>		
Closing	Door closing.	Displayed while door is closing from activation.
<b>STATUS - STOP</b>		
Stop	Door stopping.	Displayed while door is stopping from activation.
<b>STATUS</b>		
Locked	Incorrect pass code input.	Displayed when the wrong pass code is entered
Closed	Position at close limit.	
Open	Position at open limit.	
Open P1	Position at 75% of open limit.	
Open P2	Position at mid limit.	

# SECTION 6 - TROUBLESHOOTING THE CONTROLLER

## PART 3 CONTROL PANEL ERROR MESSAGES - INVERTER ERROR CODES

CODE	DESCRIPTION	PROBLEM	POSSIBLE SOLUTION
INV_ERROR_UU	DC Link low (Top Priority)	The incoming mains voltage is too low	View System Status - DC Link to check that the voltage is within the range shown.
INV_ERROR_OU	DC Link high (Medium Priority)	Either the incoming mains voltage is too high or the deceleration rate is too short	View System Status - DC Link to check that the voltage is within the range shown. Decrease the deceleration ramps.
INV_ERROR_OC1	Overcurrent 210% (Low Priority)	The motor current exceeds the inverter rating by 210%	View the Motor Current display to check the current delivered to the motor. Check the motor nameplate data to confirm that the correct controller model is being used. Check for mechanical obstruction or damage.
INV_ERROR_OC2	Overcurrent 150%/30 sec (Low Priority)	The motor current exceeds the inverter rating by 150% for more than 30 seconds	View the Motor Current display to see the current delivered to the motor. Check the motor nameplate data to confirm that the correct controller is being used. Check for mechanical obstruction or damage.
INV_ERROR_OC3	Overcurrent during acceleration	Overcurrent while accelerating	View the Motor Current display to see the current delivered to the motor. Decrease the acceleration ramps
INV_ERROR_OC4	Overcurrent DC/Brake (Medium Priority)	Overcurrent while DC braking	View the Motor Current display to see the current delivered to the motor. Decrease the DC Brake level.
INV_ERROR_OC5	Peak overcurrent (High Priority)	Severe overload	Check for: a short in the motor cable stalled motor mechanically or electrically damaged motor. If equipped with a parking brake, ensure that it is being released. Decrease the Boost parameters.
INV_ERROR_OH	Controller overheat (High Priority)	The inverter is overheated	View System Status - Temperature to check that the reported temperature is within range. Check ventilation and ensure fan, if present, is operating. Reset the controller and confirm that the fan operates for 1 second during the power-up routine. Reduce the duty cycle of the door.
INV_ERROR_12V	Low internal 12v (Top Priority)	The internal 12V DC power supply voltage is too low	View the System Status - Int Levels to check that the voltage is within range. Check I/O wiring for shorts.
INV_ERROR_24V	Low internal 24v (Top Priority)	The internal 24V DC power supply voltage is too low	View the System Status - Int Levels to check that the voltage is within range. Check I/O wiring for shorts.

# SECTION 6 - TROUBLESHOOTING THE CONTROLLER

## PART 4 CONTROL PANEL ERROR MESSAGES - DOOR CONTROL ERROR CODES

CODE	DESCRIPTION	PROBLEM	POSSIBLE SOLUTION
E01	Slip error (Low Priority)	Mechanical overload (Slip Monitoring) or missing signal from encoder.	Check door for obstruction. Ensure the pulse output from the encoder is connected to terminal P2 on the controller. Verify that the encoder pulse output is set correctly.
E02	Direction Error - occurs during setup only (Low Priority)	The direction of the motor is incorrect. The encoder count must increment positively while the door is moving in the open direction.	Use the Motor Direction parameter to set the correct direction for the motor and encoder.
E03	No Signal From Pulse Generator - occurs during setup only. (Low Priority)	No pulse input detected from the encoder.	Check door for obstruction. Ensure the pulse output from the encoder is connected to terminal P2 on the Controller. Verify that the encoder pulse output is set correctly.
E04	Speed Error	Door moves faster/slower than Expected	Check door for obstruction.
E05	N/A		
E06	N/A		
E07	Run Timer Exceeded (Low Priority)	The Run Timer has expired.	Check the Run Timer parameter to ensure a correct value.
E08	Safety Edge Test Fail (Medium Priority)	The Reversing Edge test has failed	Check the connections from the reversing edge to the controller. If using the Seywave wireless system, check operation of connected host and remote door sensor.
E09	Safety Edge Connection (Medium Priority)	The Reversing Edge connection cannot be verified.	Check the connections from the reversing edge to the controller. If using the Seywave wireless system, check operation of connected host and remote door sensor. Verify Safety edge is not activated.
E10	Safety Edge 1 Activated (Low Priority)	The Reversing Edge has been activated	Check for obstruction in door's path.
E11	Safety Edge 2 Activated (Low Priority)	The Reversing Edge has been activated	Check for obstruction in door's path.
E12	Lifting Force Exceeded (Low Priority)	The torque limit has been exceeded	If the torque limiting feature is being used, adjust the Torque Limit parameter to suit the application.
E13	No Encoder movement	Encoder did not move when expected	Check for obstruction. Check connection from Position Sensor to Motor.
E14	Absolute Encoder Comm Loss (Top Priority)	Communication with the absolute encoder has been lost.	Check the connections between the encoder and the controller.
E15	Installation Fault (Low Priority)	An error occurred during Quick Setup	Re-perform Quick Setup
E16	Encoder fault	Encoder communication is not correct	Check Position Sensor. Verify connections.

# SECTION 6 - TROUBLESHOOTING THE CONTROLLER

## PART 4 CONTROL PANEL ERROR MESSAGES - DOOR CONTROL ERROR CODES (continued....)

CODE	DESCRIPTION	PROBLEM	POSSIBLE SOLUTION
E17	Reset Limits (HIGH PRIORITY)	The position limits cannot be verified	Perform a Quick Setup
E18	Wireless Airlock Failed to Authorize Opening (Low Priority)	The controller failed to receive an Airlock request acknowledgement.	Check opposite controller to ensure that it is operational. Check that both controllers have been wirelessly connected together and that each controller has Wireless and Airlock enabled. Disconnect controllers and run a discovery to reconnect controllers.
E19	Wireless No Response	There was no response from the onboard wireless	Ensure that the Wireless is Enabled then power cycle the controller.
E20	Backroll error	Door movement when at idle state	Verify there are no obstructions, verify motor gear box is functional.
E21	Option - Seywave OCS Remote Timeout	A paired Seywave wireless O/C/S remote has timed out.	Check the remote for operation. Refer to supplied Seywave Wireless manual for troubleshooting.
E22	Option - Seywave DS Remote Timeout	A paired Seywave wireless Door Sensor remote has timed out.	Check the remote for operation. Refer to supplied Seywave Wireless manual for troubleshooting.
E23	Option - Seywave DS Connection Fault	A paired Seywave wireless Door Sensor remote has reported a connection fault.	Check the connection and remote for operation. Refer to supplied Seywave Wireless manual for troubleshooting.
E24	N/A		
E25	Manual Crank input active (Medium Priority)	Manual Crank is off the Support Bracket	Put Hand Crank back on the Support Bracket.
E26	Overtravel error (HIGH PRIORITY)	Door moves beyond limits.	Reset limits
E27	Photoeye connection test fail (Medium Priority)	Monitored Photoeye connection test failed.	Check photoeye connections
E28	Photoeye 1 activation (Low Priority)	Photoeye 1 has detected an obstruction.	Check for obstructions in photoeye path
E29	Photoeye 2 activation (Low Priority)	Photoeye 2 has detected an obstruction	Check for obstructions in photoeye path
E30	Input Timer Exceeded	Input activation lasting longer than 2 minutes.	Verify wall buttons are not stuck. Check connections for a short.

## PART 5 CONTROL PANEL ERROR MESSAGES - ERROR CODE PRIORITY LEVELS

Priority Level	Reset Condition	Comment
Low	Activation input	Can also be reset by higher priority reset conditions
Medium	Stop, E-Stop or Menu/Enter button pressed	Can also be reset by higher priority reset conditions
High	Menu/Enter button pressed and held for 2 seconds.	Screen Flashes
Priority Reset Limits	Successful Quick Setup	Auto-clears when limits are set
Priority Encoder Connection	Communication restored between encoder and controller	Auto-clears when fault no longer exists
Priority INV_ERROR_UU	Incoming main voltage is within range	Auto-clears when fault no longer exists
Priority INV_ERROR_12VInternal 12V	Internal 12V DC level is within range	Auto-clears when fault no longer exists
Priority INV_ERROR_24V	Internal 24V DC level is within range	Auto-clears when fault no longer exists

# SECTION 7 - SERVICE AND MAINTENANCE

## ⚠ WARNING

Failure to perform specified inspections, service, and maintenance may result in an unsafe condition, will void limited warranty, and may result in premature failure of the unit. Service and Maintenance are necessary to ensure safe operation of the High Speed Metal Door.

**Table 7A provides a schedule of Service and Maintenance items.** To the right is a list of service and maintenance highlights.

INSTALLATION DATE: \_\_\_\_\_ INSTALLER INITIAL: \_\_\_\_\_

SERVICE ITEM	SERVICE INTERVAL (frequency)		
	EVERY DAY	EVERY 6 MOS. or 50,000 CYCLES	EVERY 12 MOS. or 100,000 CYCLES
General Inspection		•	
Limit Switch Chain Tension and Alignment		•	
Manual Operation of Door		•	
Sensing Edge & Light Curtain systems	•		
Mounting Bolt Tightness			•
Motor Brake Gap and Motor			•
Check Limit Position		•	
Check Emergency Brake Activation List		•	

**TABLE 7A**

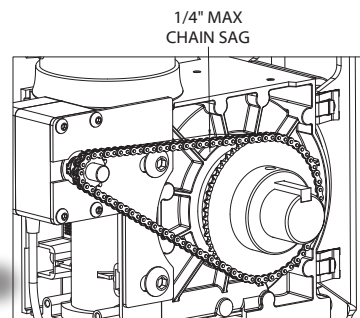

**FIG 7B**

### General Maintenance Interval Message

- Upon reaching 150,000 door cycles (300,000 & 450,000, etc.), the panel will display general maintenance needed.
- Contact your distributor to have required maintenance performed.
- Once service is completed, clear the service message by going into System Configuration ->System -> Clear Service.

### Sensing Edge & Light Curtain systems

- Test sensing edge activation daily.
  - Place a solid object, higher than 12", on floor and close door. Sensing edge should reverse door direction on contact with object.
- Test light curtain activation daily.
  - Obstruct the light curtain beam with a solid object. Light curtain should reverse door direction.

### General Inspection

- Visually inspect wiring conduit and cables.
- Inspect fixtures such as: Bearings, conduit boxes, hood, gear box (for oil leakage), motor.
- Inspect safety labels, placement and condition.
- Lubricate guides with paste wax or silicone spray.

### Position Sensor Chain Tension and Alignment

- Check sprocket alignment.
- Check chain tension, max sag is 1/2", **Fig 7B**.
- Lubricate chain.

### Manual Operation of Door

- Inspect door alignment and level.
- Inspect curtain and endlocks for damage.
- Inspect guides, sensing edge and hood for damage.

### Mounting Bolt Tightness

- Check fasteners anchoring headplates and door guides to wall.

### Check Limit Position

- Verify the door stops at correct open position.
- Verify that door closes fully without excessive "stacking" of curtain in guides.
- Verify approach speeds provide for smooth starts and stops.

**Keep records of all service and maintenance.**

# APPENDIX A - CONTROL PANEL WIRE DETAIL

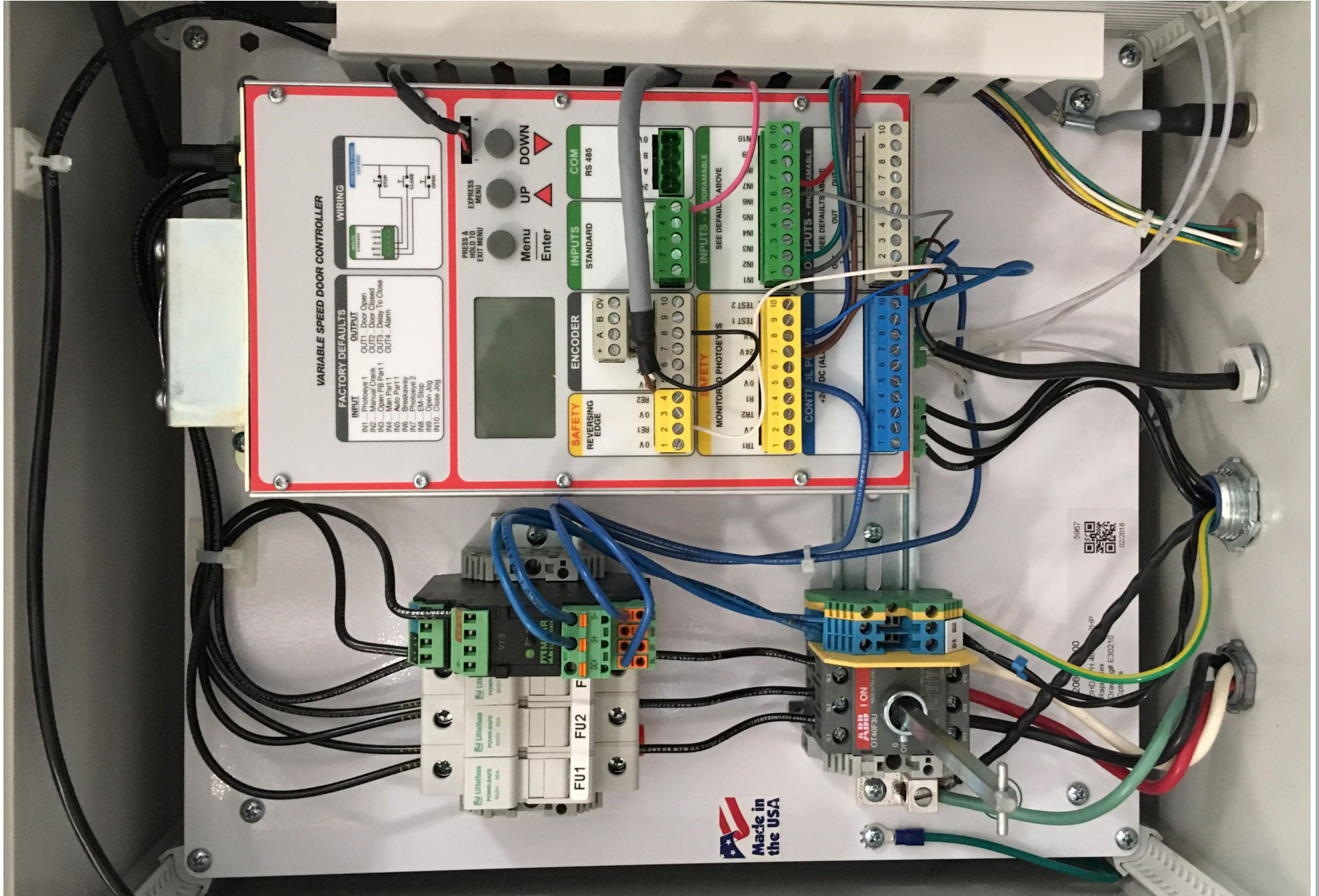

# APPENDIX B - OPTIONAL ACCESSORY WIRING

## RADIO RECEIVER

FIG B1

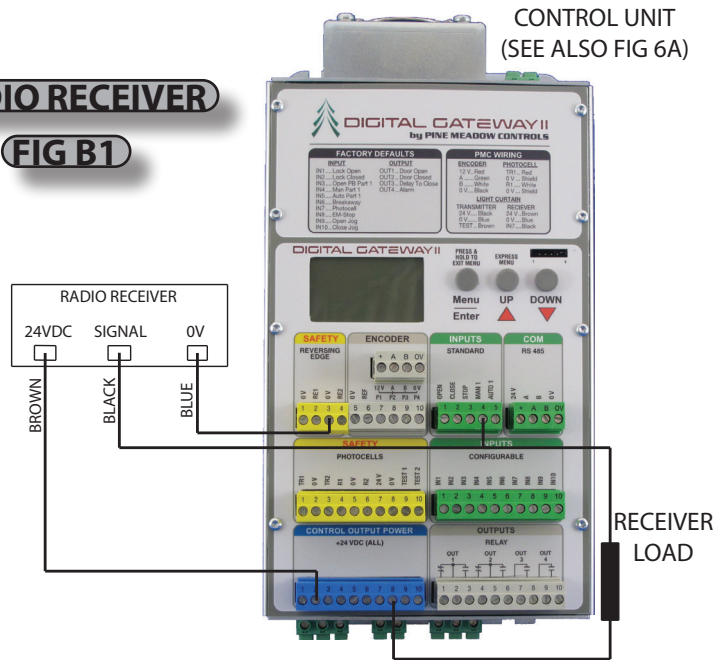

## MOTION DETECTOR

FIG B2

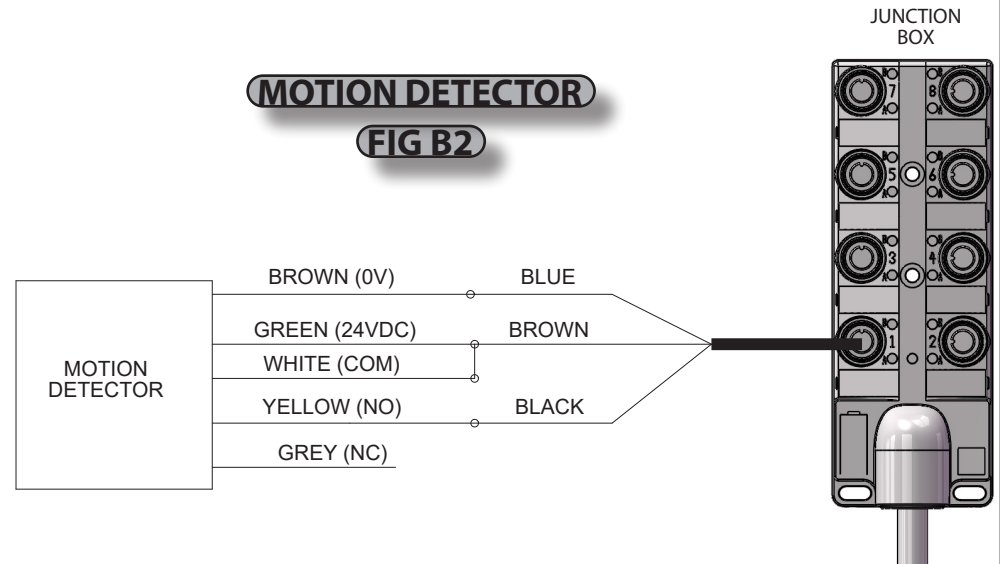

## LOOP DETECTOR

FIG B3

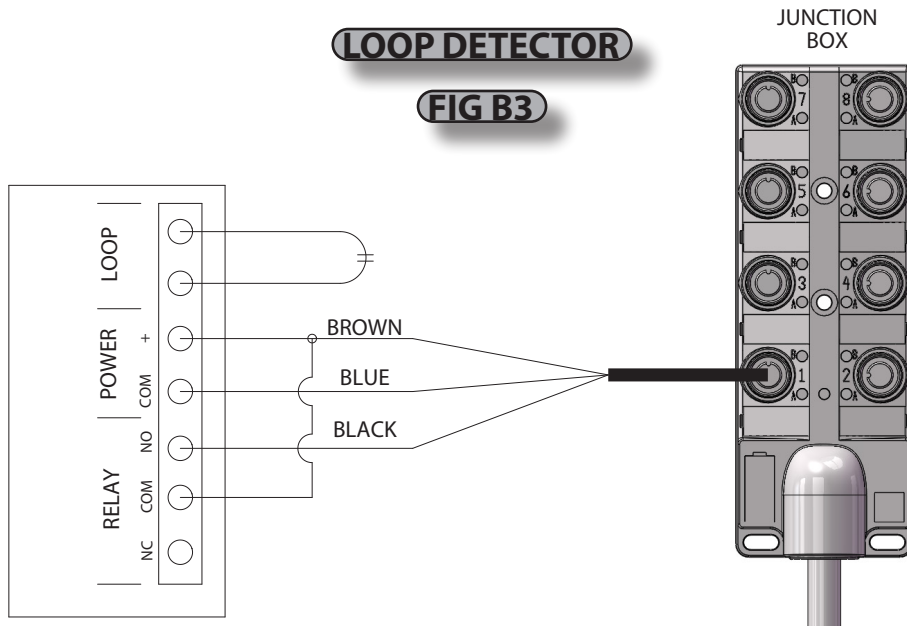

## CAUTION

Door will open/close once connected.