

INSTALLATION INSTRUCTIONS ADV-X HIGH SPEED METAL DOORS MODELS 888 AND 889



This installation manual provides the trained door technician information required to install a ADV-X High Speed Metal door. READ COMPLETE INSTRUCTIONS BEFORE INSTALLING DOOR.

Some installation tasks listed in this document are found in other documents. Please refer to the appropriate document(s) as directed;

827805 Installation Instructions VFD for High Speed Metal Doors (Included)

308577 Hilti Kwik Bolt Installation found on Ribbon Connect

This manual is intended ONLY for professional use by a trained door systems technician. All others please refer to the end user manual provided to you.

Product may be covered by one or more patents. See www.wayne-dalton.com/patents for details.



TABLE OF CONTENTS		
SECTION	CONTENTS	PAGES
1	SAFETY INFORMATION	3
2	INSTALLATION	4-18
3	FIRST MANUAL DOOR OPERATION	19-20
4	ELECTRONIC	21
5	TENSION SENSOR ADJUSTMENT	22-23
6	FINAL INSTALLATION STEPS	24
7	BREAKDOWN OF PARTS	25-26
	WARRANTY	27

SECTION 1 - SAFETY INFORMATION

OVERVIEW OF POTENTIAL HAZARDS READ THIS SAFETY INFORMATION

WARNING

High Speed Metal Doors doors are large, heavy objects that move with the help of electric motors. Since moving objects and electric motors can cause injuries, your safety and the safety of others depends on you reading the information in this manual. If you have any questions or do NOT understand the information presented, call technical support at 1-800-764-1457 option 4.



1. Read manual and warnings carefully.
2. All models are equipped with an over current device. This must be manually reset following an over current condition.

In this section and those that follow, the words "**DANGER**", "**WARNING**", and "**CAUTION**" are used to stress important safety information. The word:

- ▲ **DANGER** indicates an imminently hazardous situation which, if not avoided, will result in death or serious injury.
- ▲ **WARNING** indicates a potentially hazardous situation which, if not avoided, could result in death or serious injury.
- ▲ **CAUTION** indicates a potentially hazardous situation which, if not avoided, may result in injury or property damage.

The word **NOTE** is used to indicate important steps to be followed or important considerations.



POTENTIAL HAZARD	EFFECT	PREVENTION
 <p>MOVING DOOR</p>	<p>▲ WARNING Can Cause Serious Injury or Death</p>	<p>Do NOT operate unless the doorway is in sight and free of obstructions. Keep people clear of opening while door is moving. Do NOT change control to momentary contact unless an external reversing means is installed. Do NOT operate the door if it doesn't operate freely.</p>
 <p>MOVING DOOR</p>	<p>DANGER Can Cause Serious Injury or Death</p>	<p>Do NOT operate the door unless header is clear of persons or property. Lockout / Tagout before servicing.</p>

SECTION 2 - INSTALLATION

UNPACKING COMPONENTS



CAUTION
Lift from below with forklift. Do not lift with the shafts. This could cause damage or personal injury.



WARNING
Use designated lifting hole and appropriate lifting equipment to avoid damage, serious injury or death.

SIDE PLATES
REMOVE FIRST

HEADER ASSEMBLY
REMOVE LAST

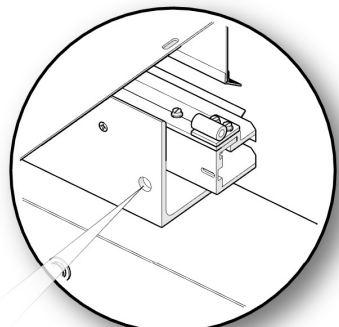

LIFTING HOLE IN
STRUCTURAL ANGLE
INSIDE GUIDE

MOTOR,
CONTROLLER, AND
HARDWARE BOX
REMOVE FIRST



CAUTION
Team lift to avoid injury.

GUIDES
REMOVE LAST

HEADER
CRATE

COUNTERWEIGHTS REMOVE SECOND
NOTE: THERE ARE NO COUNTERWEIGHTS
ON SLIM GUIDE CONFIGURATIONS.



CAUTION
Use forklift to avoid injury.

GUIDES
CRATE

SECTION 2 - INSTALLATION

SITE PREPARATION

NOTE: Check that the floor, jamb, and header are level, square, and plumb. If they are not, you will need to add shims as necessary. A laser level is highly recommended for this job.

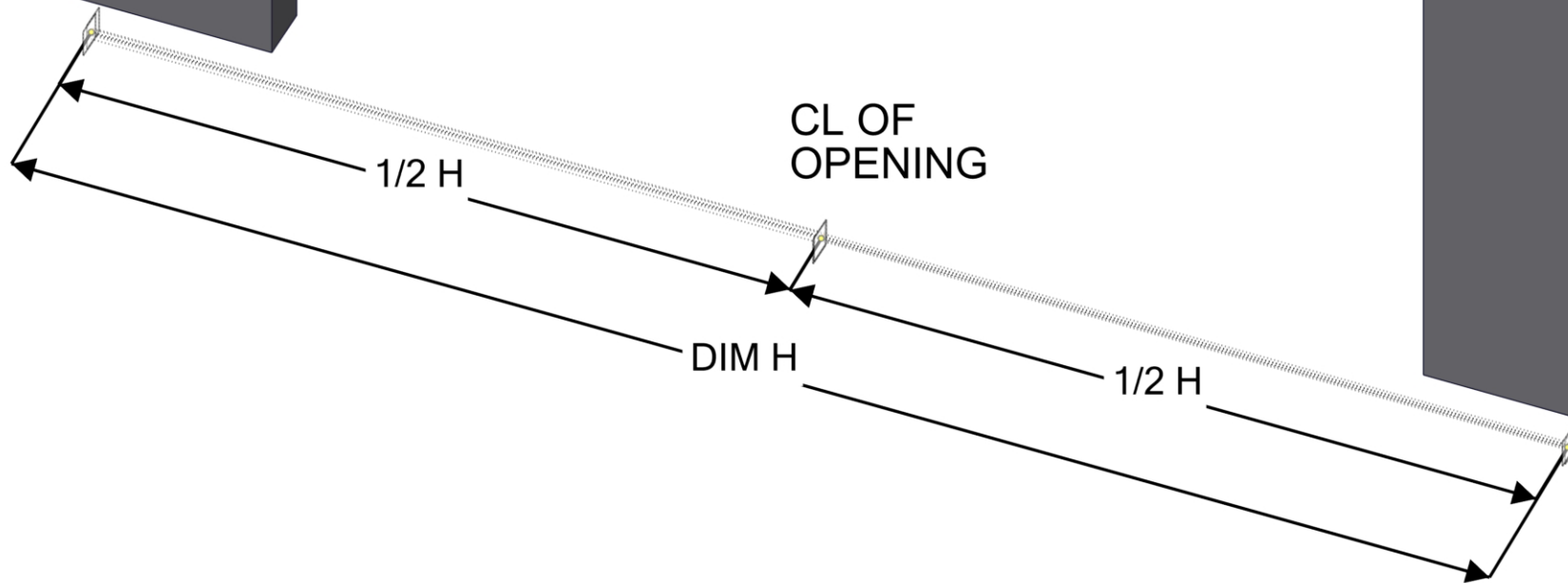

NOTE: Mark the floor in three places to help align the guides that will be placed in the following step.

SECTION 2 - INSTALLATION

GUIDE INSTALLATION



WARNING
Use designated lifting hole and appropriate lifting equipment to avoid damage, serious injury or death.

NOTE: Guide covers swing open on hinges, or can be lifted off hinge pins and removed to ease installation.

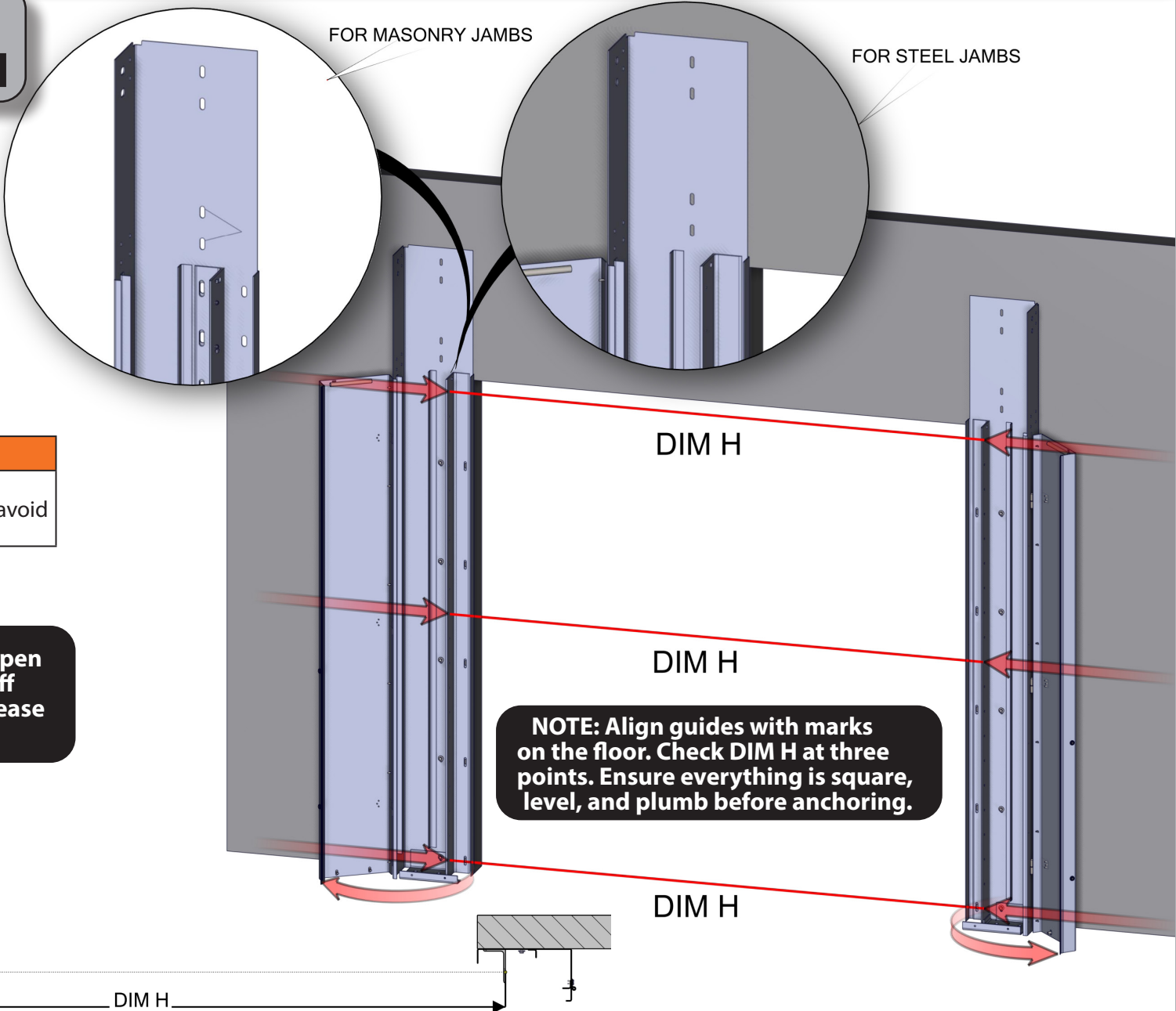

NOTE: Align guides with marks on the floor. Check DIM H at three points. Ensure everything is square, level, and plumb before anchoring.

NOTE: DIM H is measured from outside of track angle to outside of the opposite track angle.

SECTION 2 - INSTALLATION

GUIDE INSTALLATION

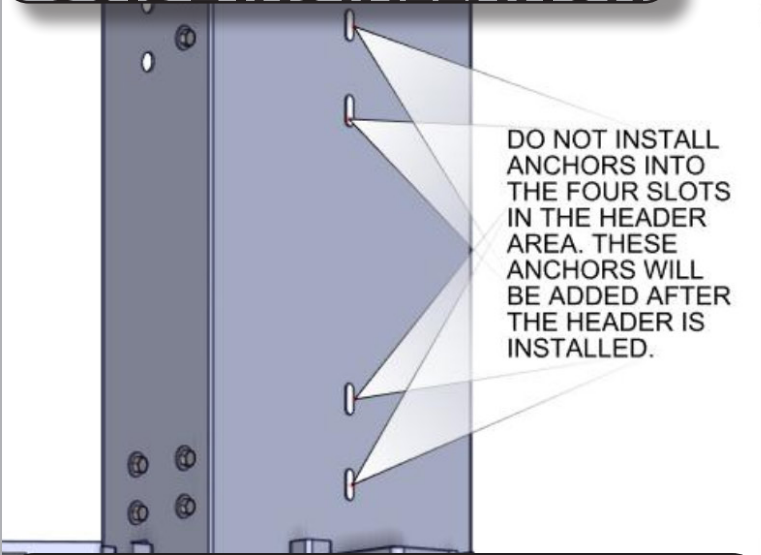

Attach the guides to the wall using the slots except for the top four slots.

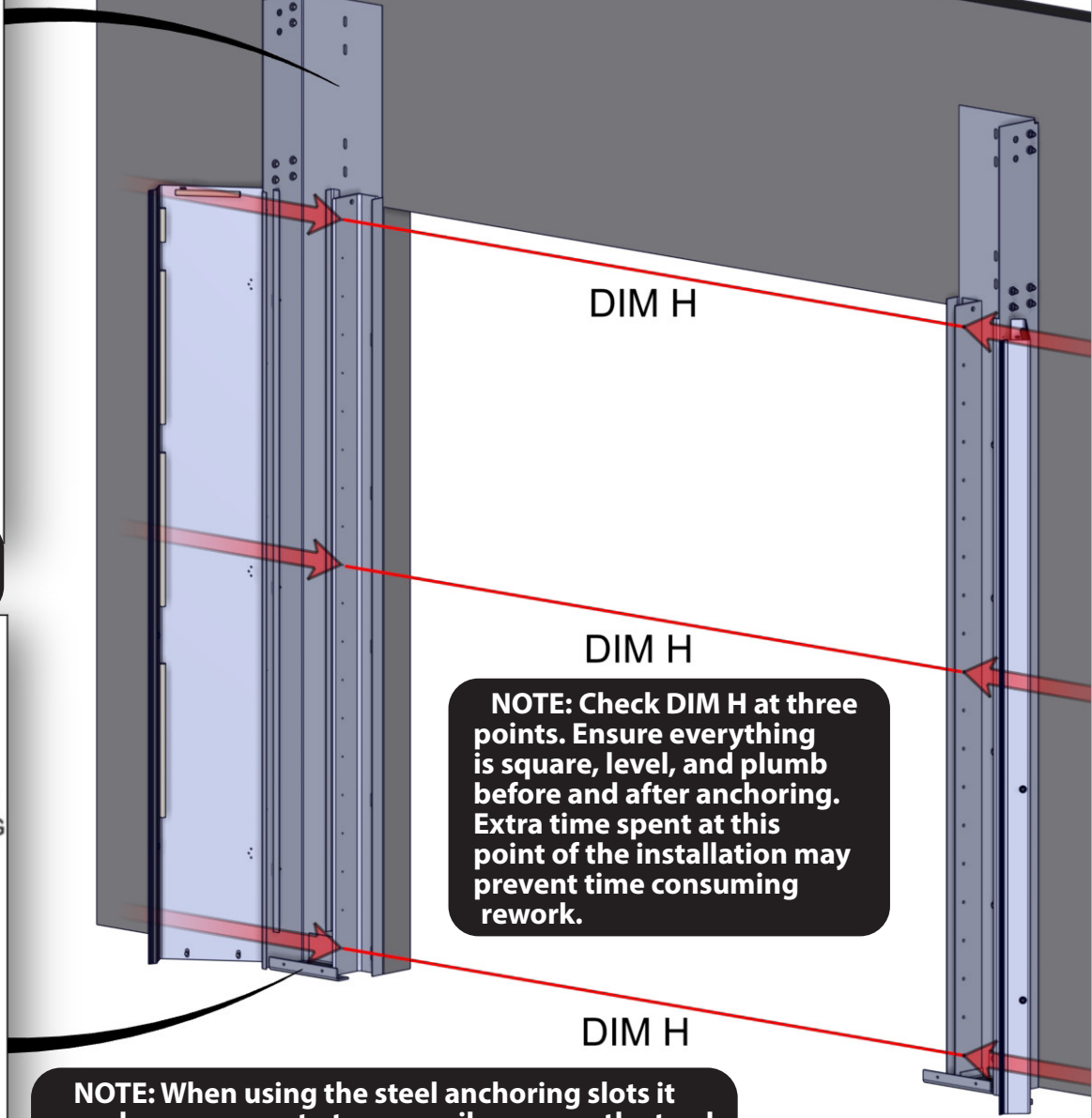
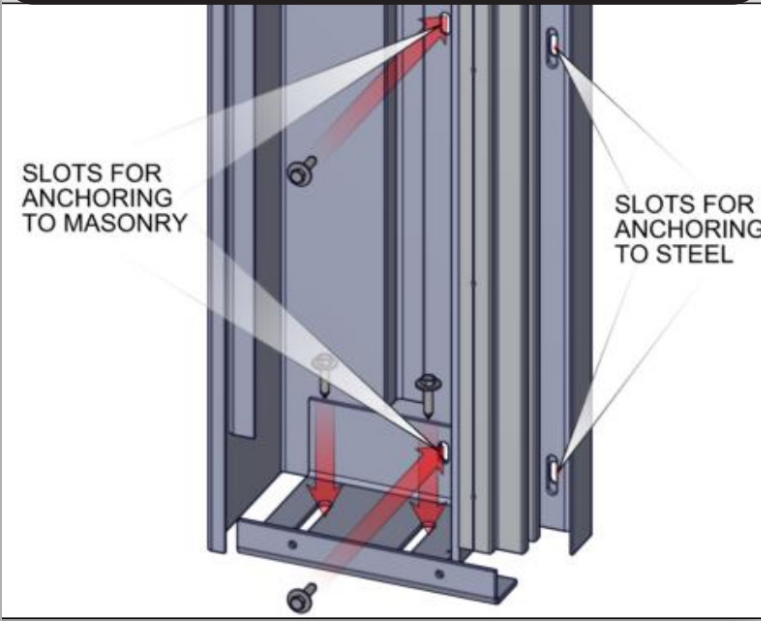

NOTE: When using the steel anchoring slots it may be necessary to temporarily remove the track for access.

SECTION 2 - INSTALLATION

HEADER ASSEMBLY INSTALLATION

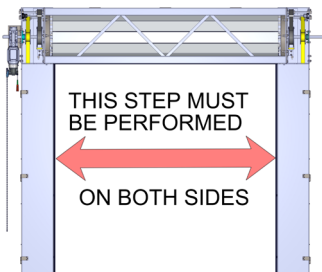
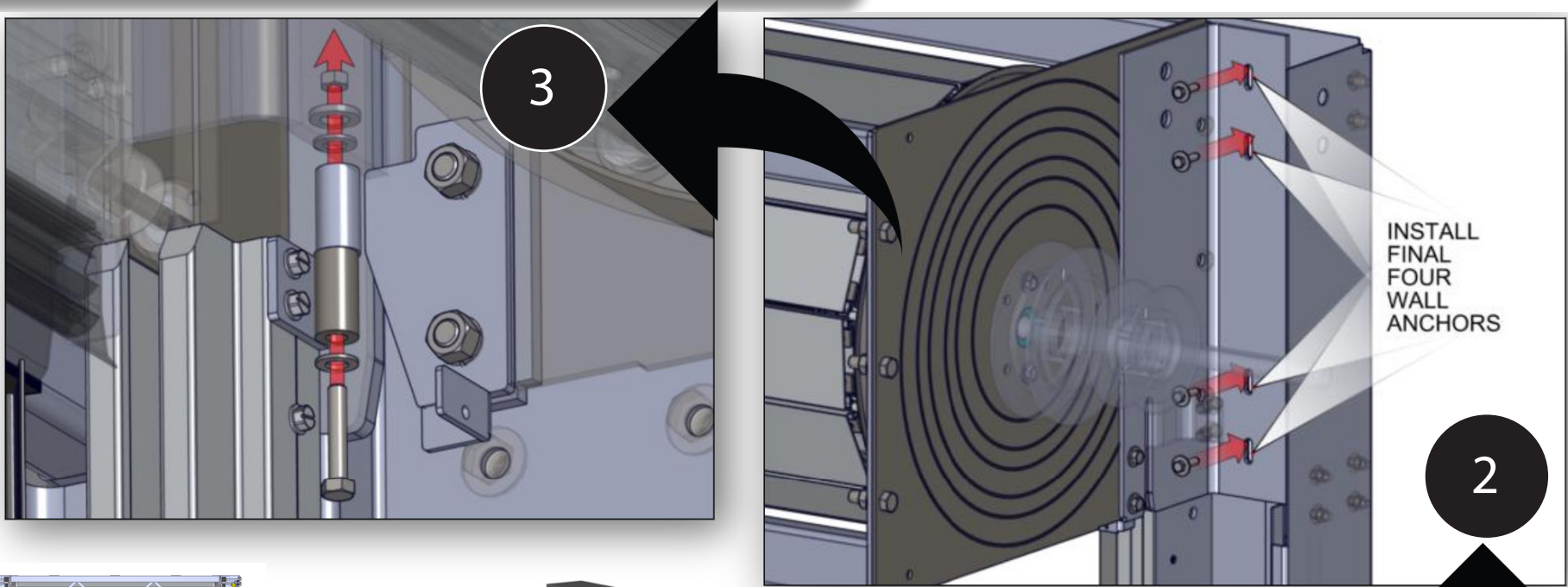

WARNING
Use appropriate lifting equipment to avoid serious injury or death.

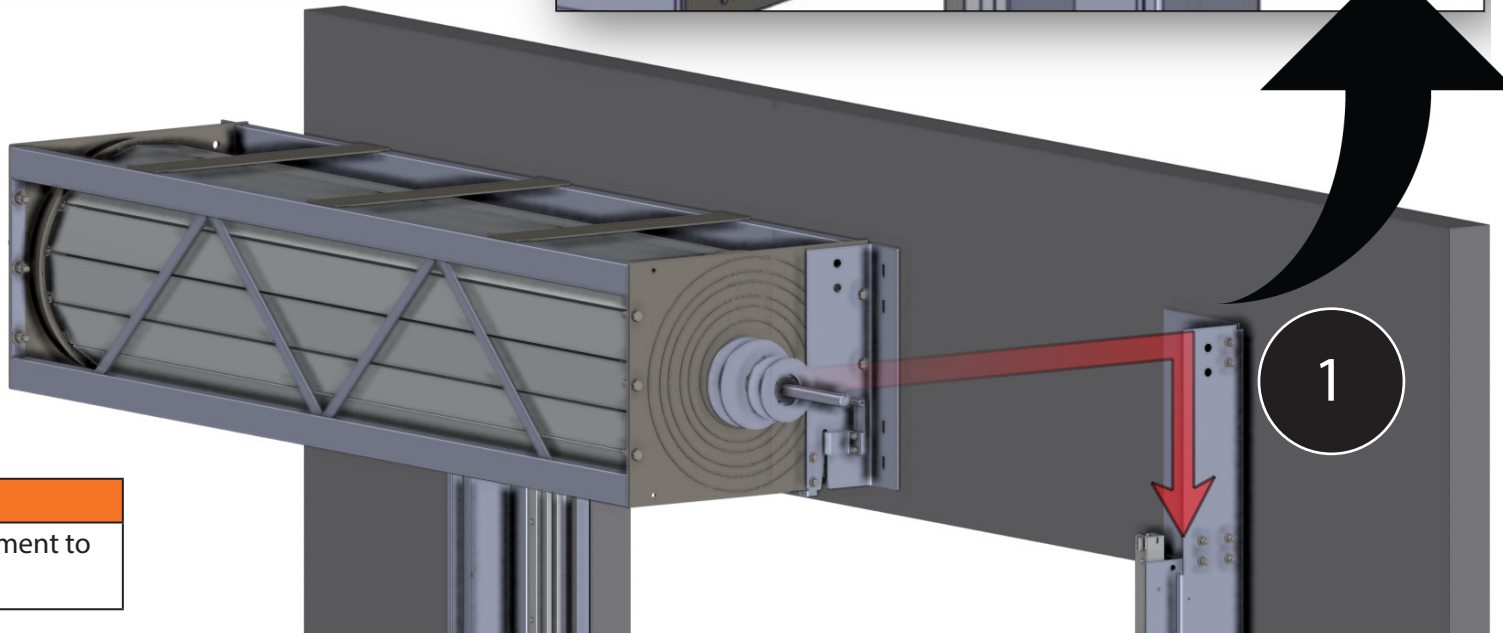

SECTION 2 - INSTALLATION

SIDE PLATE INSTALLATION

NOTE: Only loosely install side plate bolts. You will need some movement in the side plate to complete the next step.

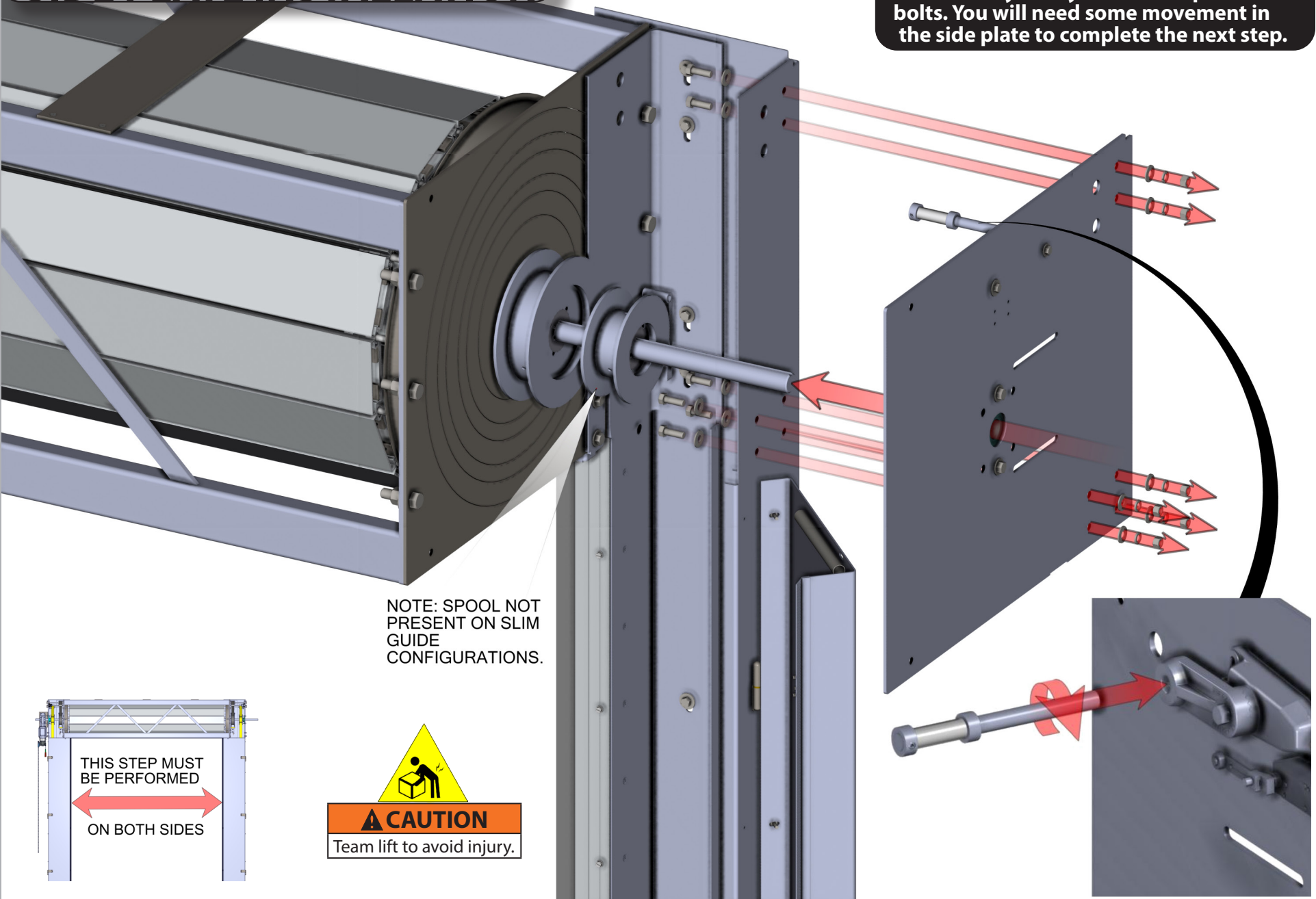

NOTE: SPOOL NOT PRESENT ON SLIM GUIDE CONFIGURATIONS.

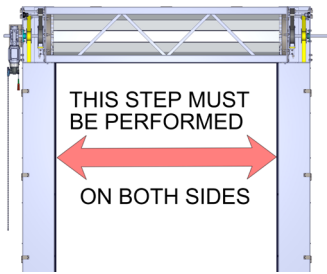

SECTION 2 - INSTALLATION

IDLER PULLEY INSTALLATION WITH STANDARD CONFIGURATION

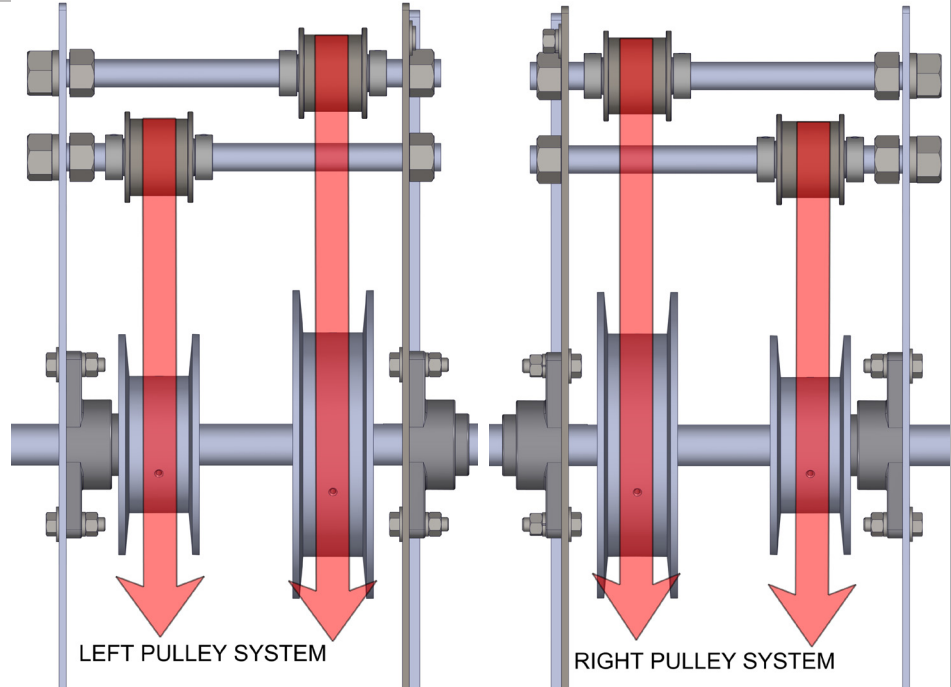
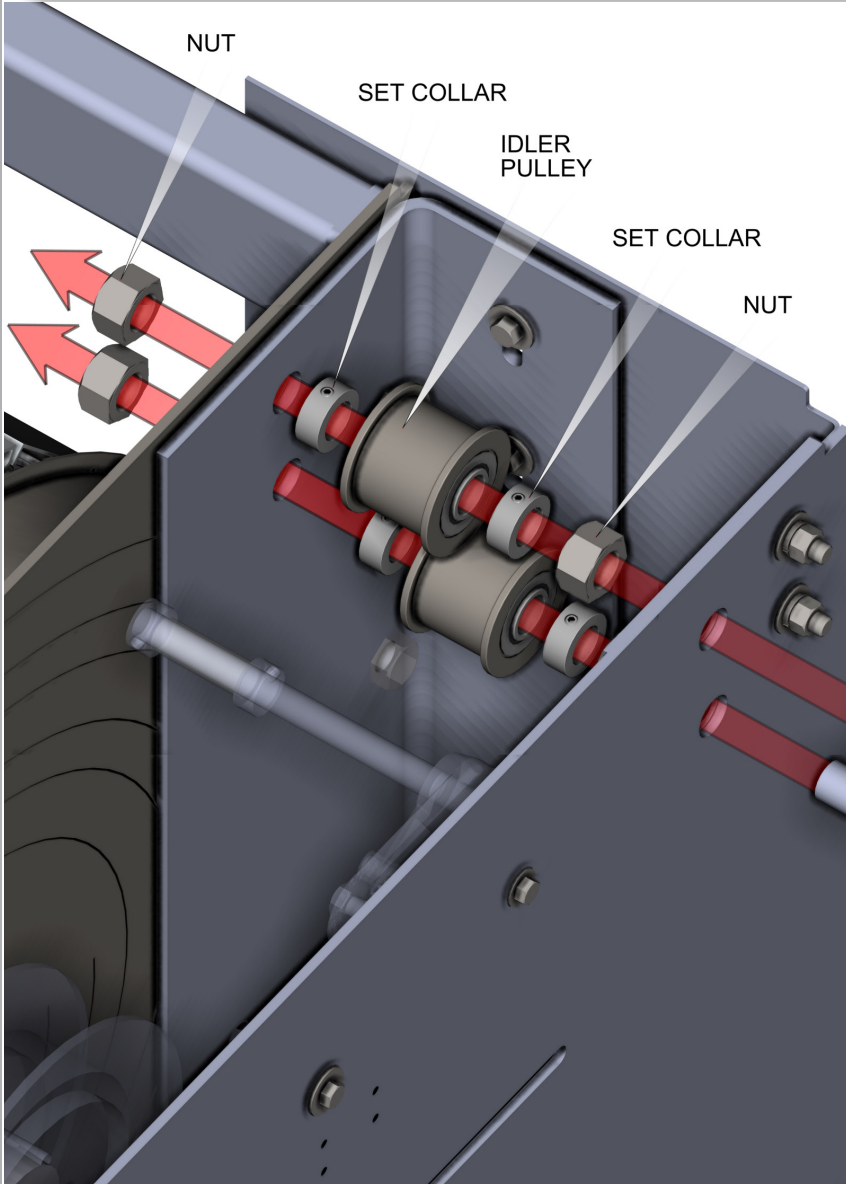

NOTE: Check alignment of pulleys and tighten set screws in set collars and bearings to prevent excessive wear on the belts.

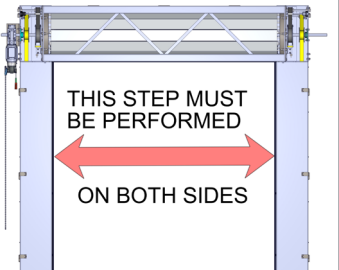
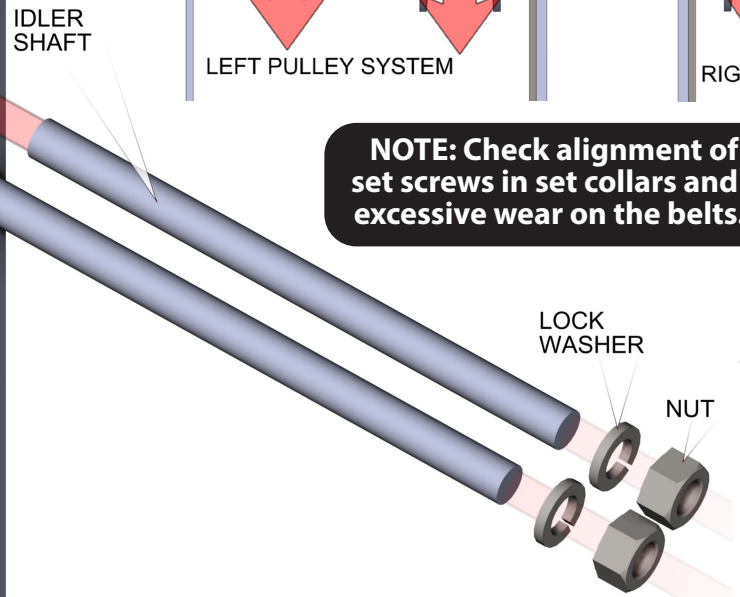

SECTION 2 - INSTALLATION

IDLER PULLEY INSTALLATION WITH SLIM GUIDE (NO COUNTERWEIGHTS) CONFIGURATION

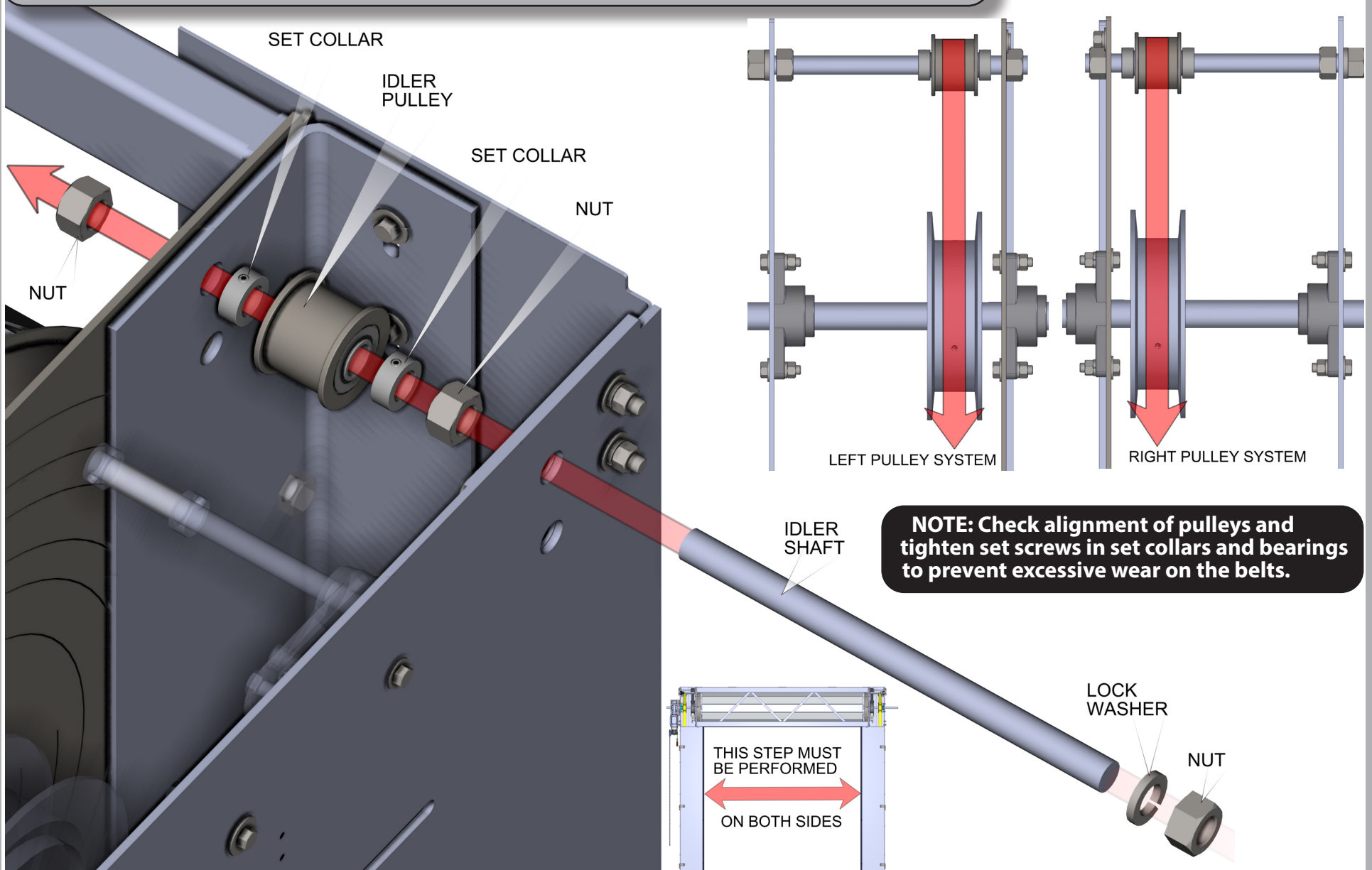

SECTION 2 - INSTALLATION

SIDE PLATE BRACKET INSTALLATION

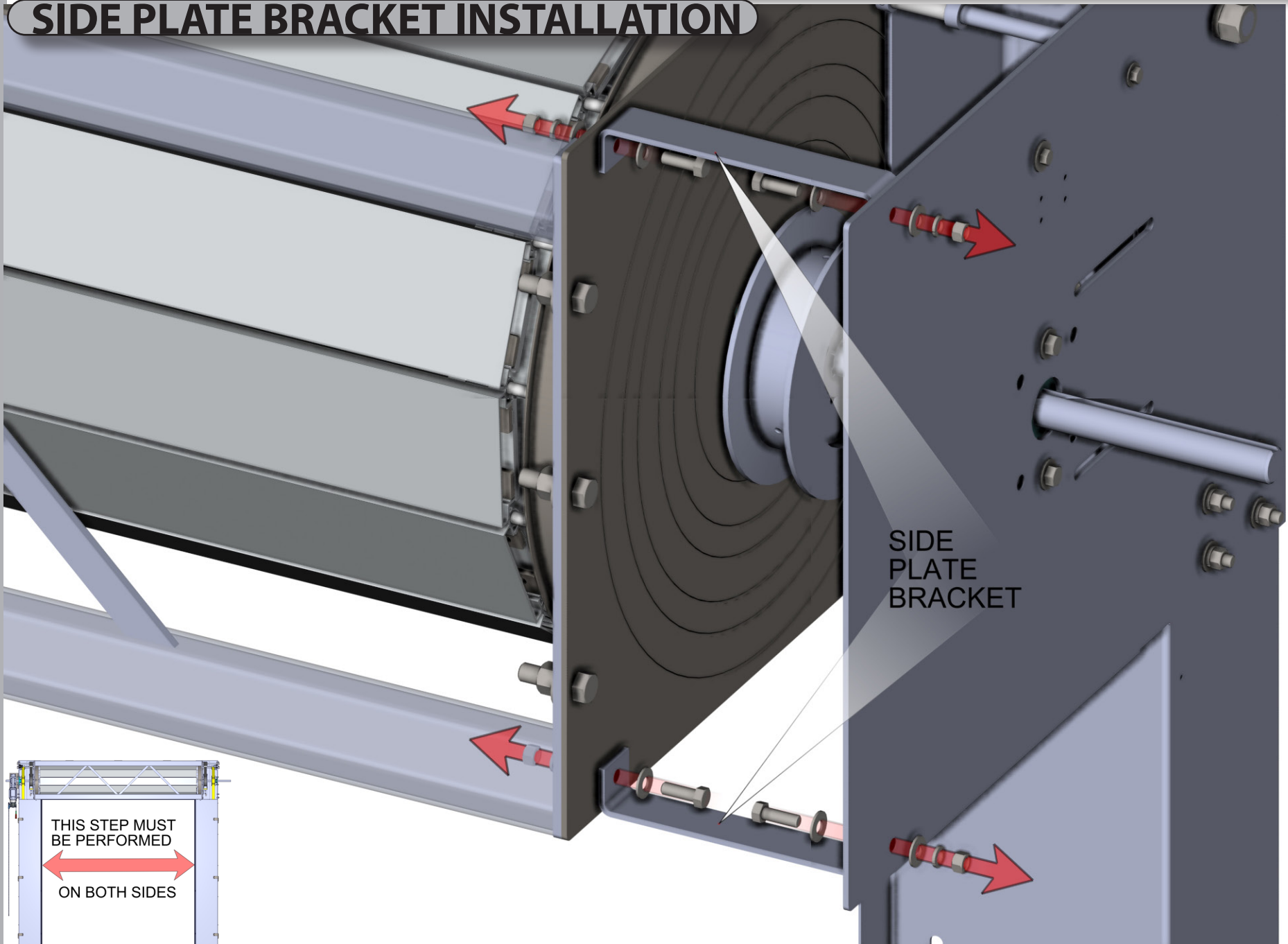

SECTION 2 - INSTALLATION

BELT INSTALLATION WITH STANDARD CONFIGURATION

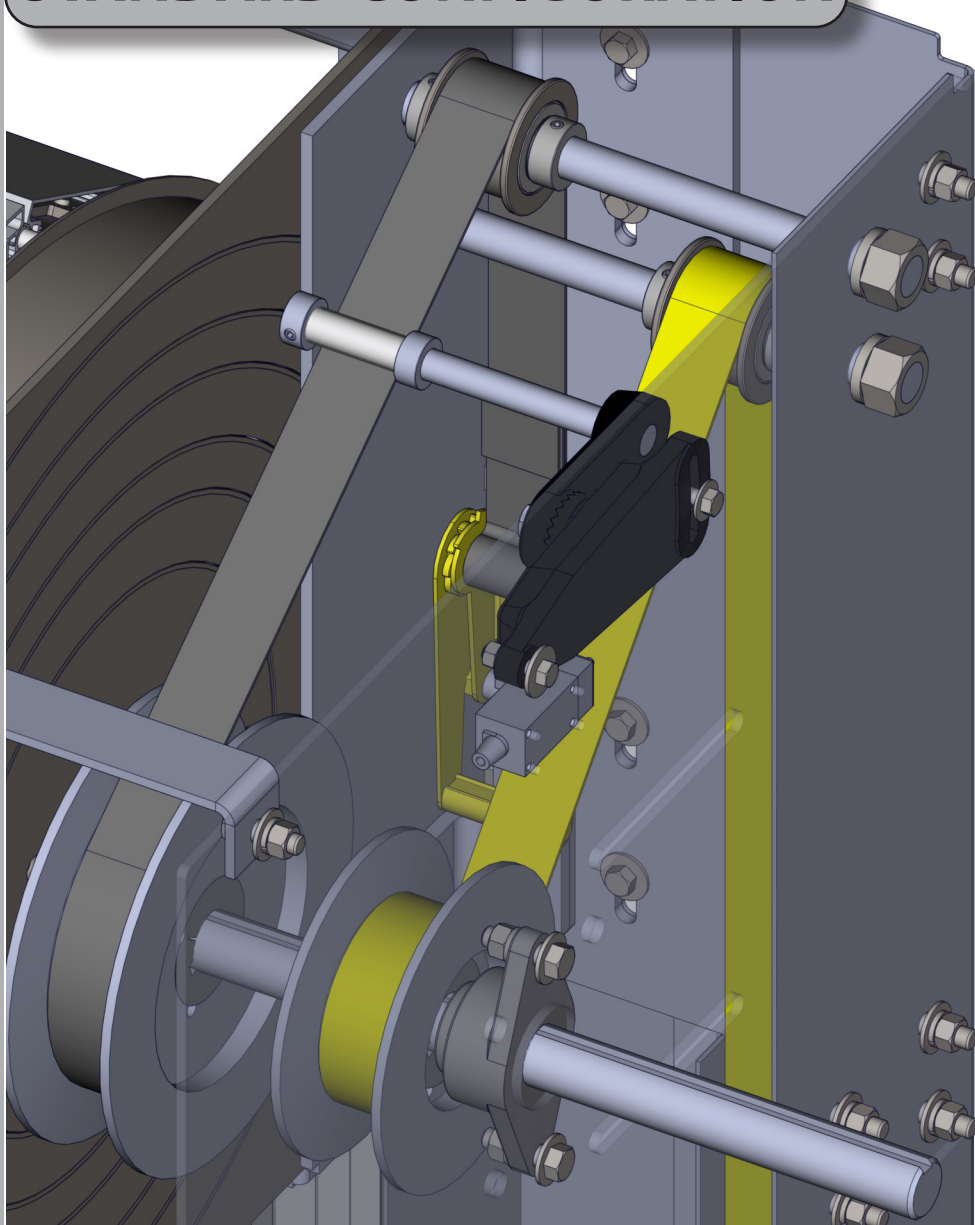

NOTE: Counterweight belt is yellow. Drive belt is grey.

NOTE: Check that the drive belts are equal in length. Unwind the drive belt on both sides and count the number of wraps to be sure before connecting to the curtain.

NOTE: Counterweight belt is fed underhand up to the idler pulley. The drive belt is fed overhand up under the belt tensioner and toward the idler pulley.

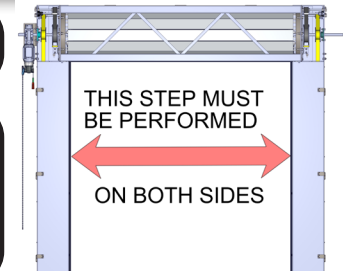

COUNTERWEIGHT BELT (YELLOW)

DRIVE BELT (GREY)

BELT TENSIONER PIN

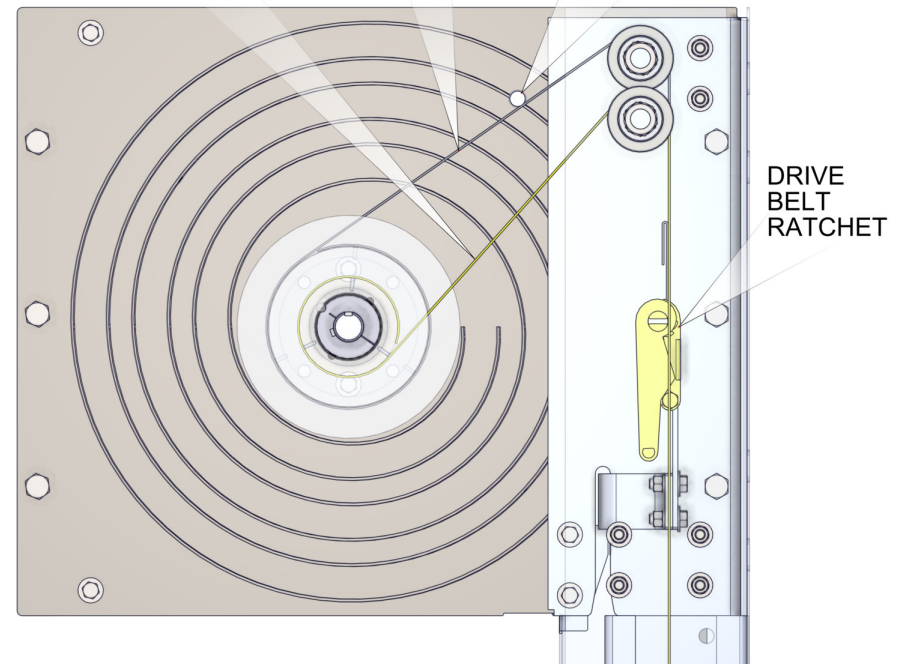

SECTION 2 - INSTALLATION

BELT INSTALLATION WITH SLIM GUIDE (NO COUNTERWEIGHTS) CONFIGURATION

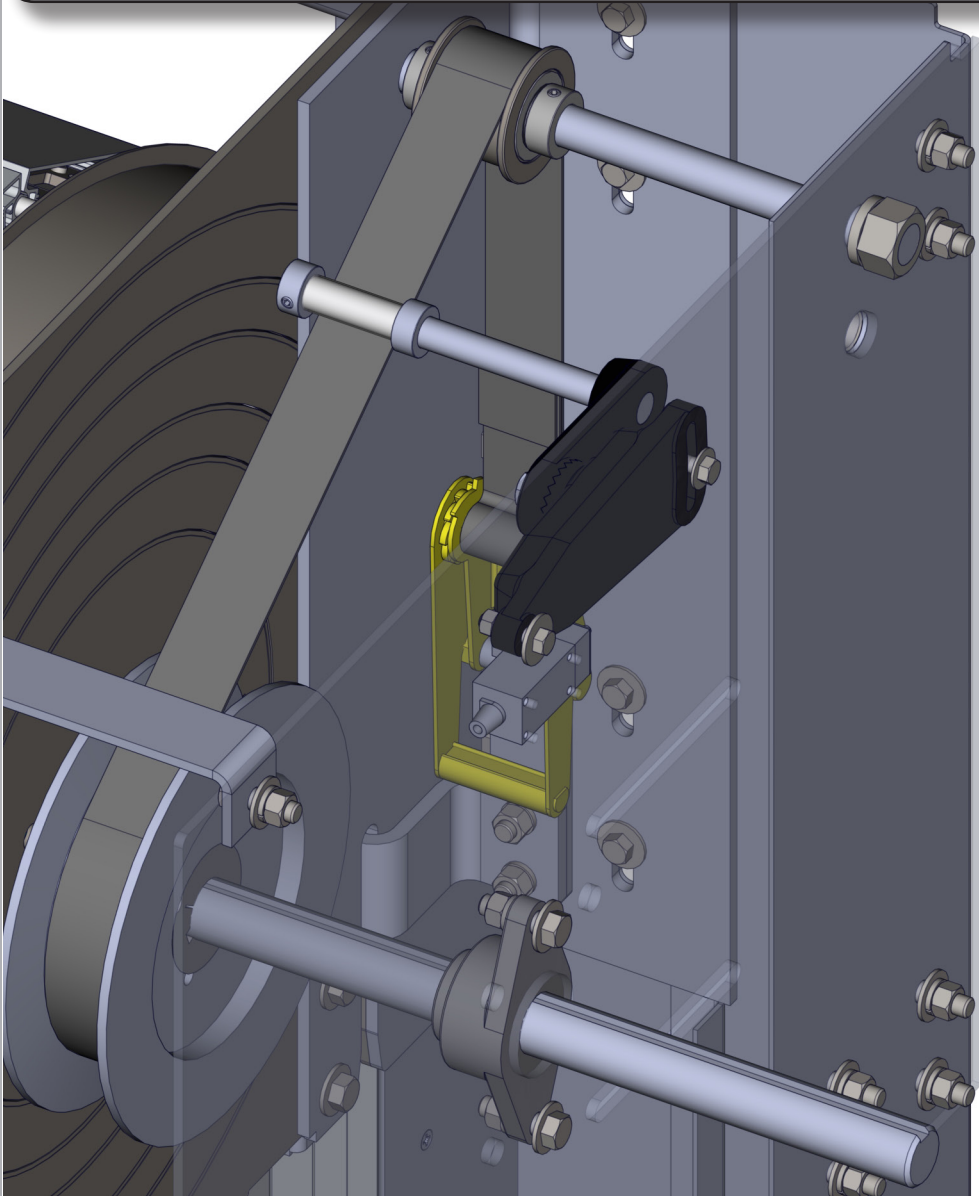

NOTE: Check that the drive belts are equal in length. Unwind the drive belt on both sides and count the number of wraps to be sure before connecting to the curtain.

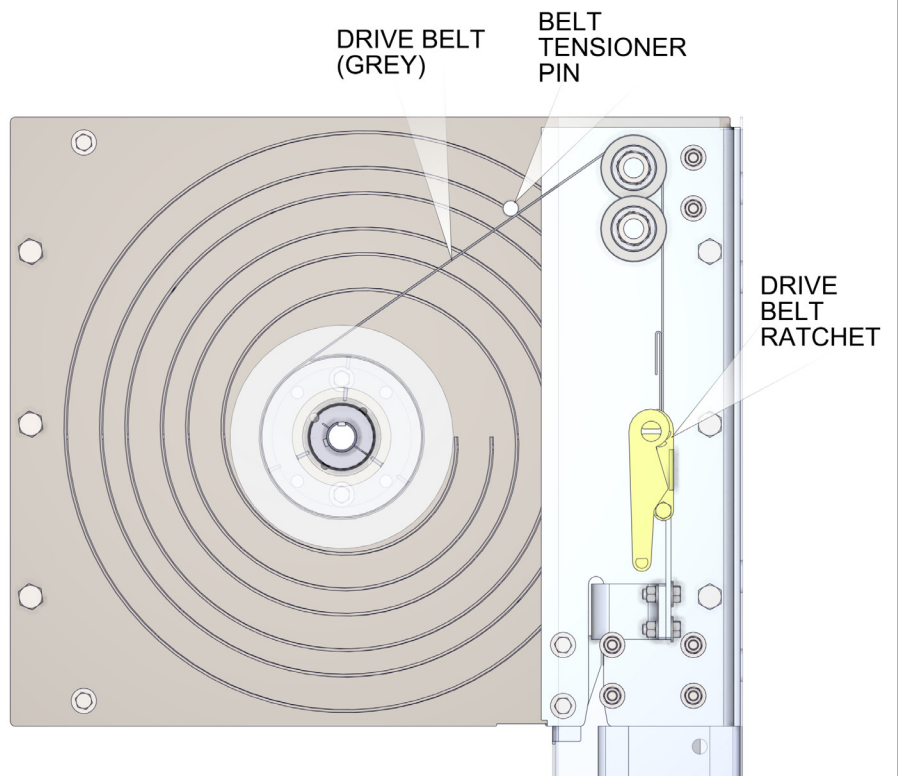
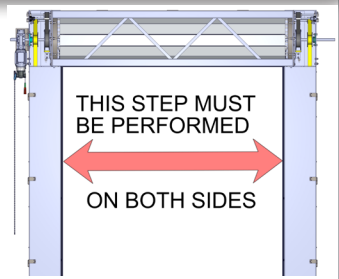

SECTION 2 - INSTALLATION

MOTOR INSTALLATION



CAUTION

Team lift to avoid injury.

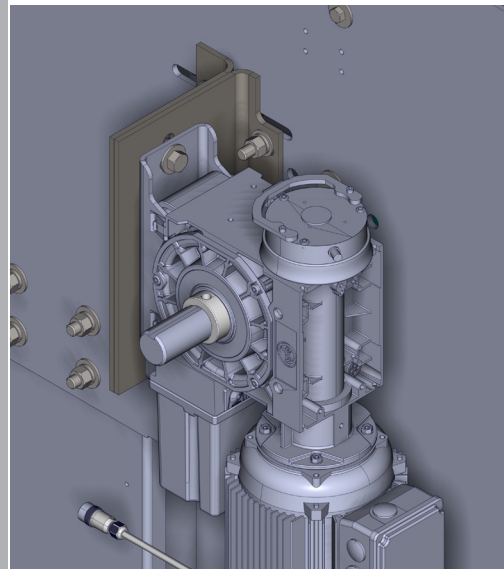
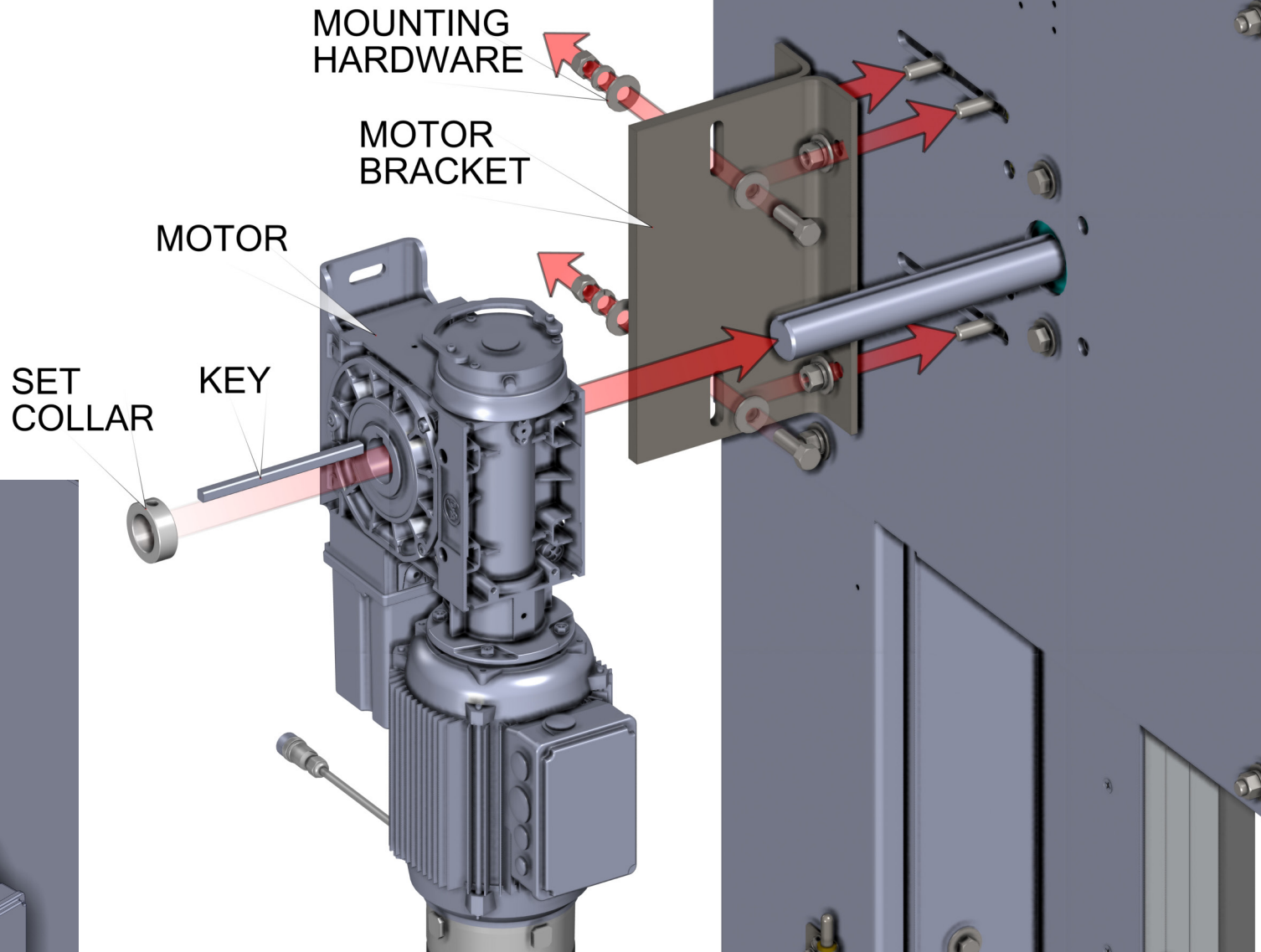

SECTION 2 - INSTALLATION

COUNTERWEIGHT INSTALLATION

NOTE: Skip this step for slim guide configuration.



WARNING
Use appropriate lifting equipment to avoid serious injury or death.

NOTE: The assembly of the front sliders may be easier if done after raising the counterweight up off the spacers a little using the ratchet.

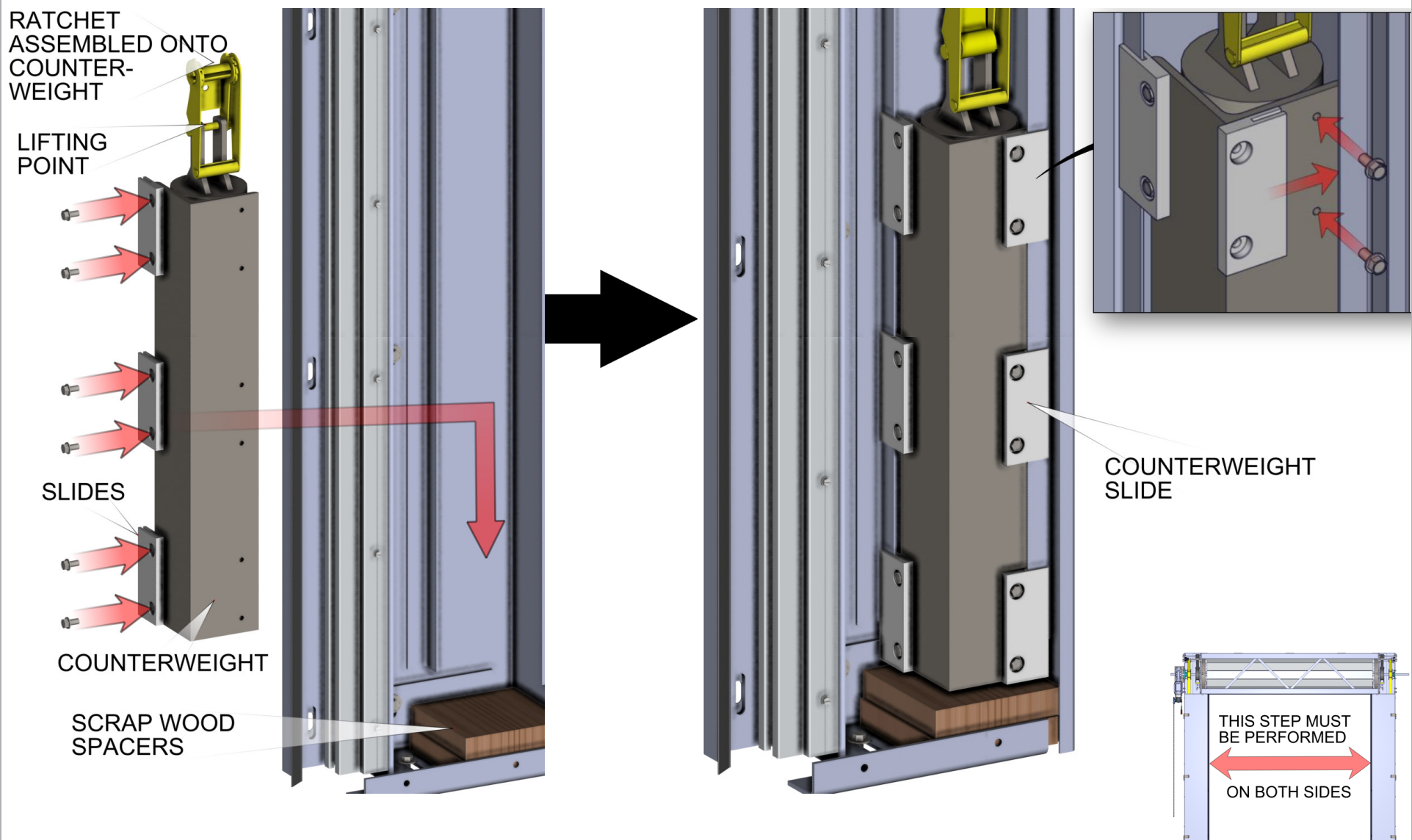

SECTION 2 - INSTALLATION

COUNTERWEIGHT INSTALLATION

NOTE: Skip this step for slim guide configuration.

NOTE: Assemble belt clamp after the counterweight has been raised into the proper position using the ratchet.

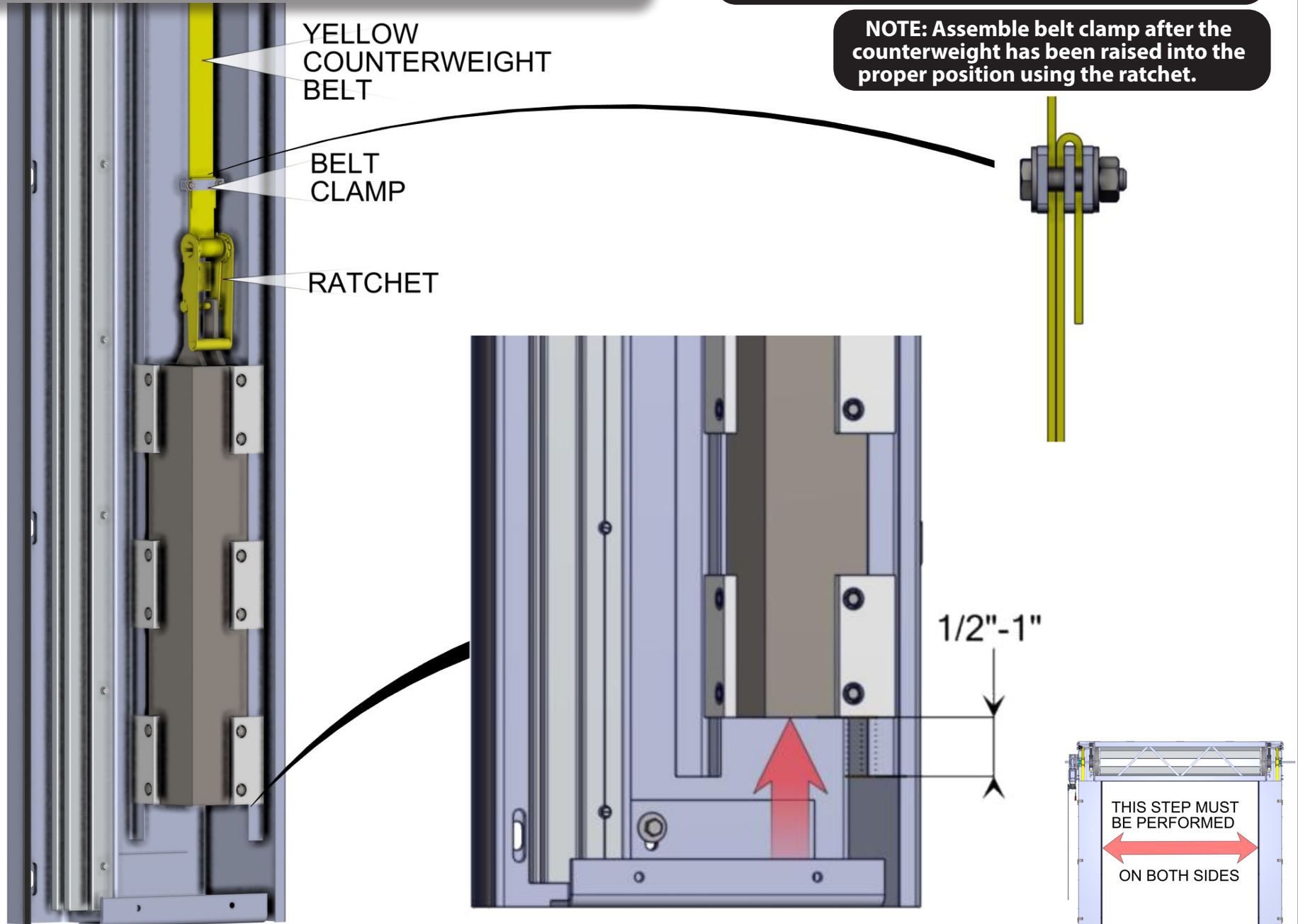

SECTION 2 - INSTALLATION

FLIP SHIPPING BRACKET

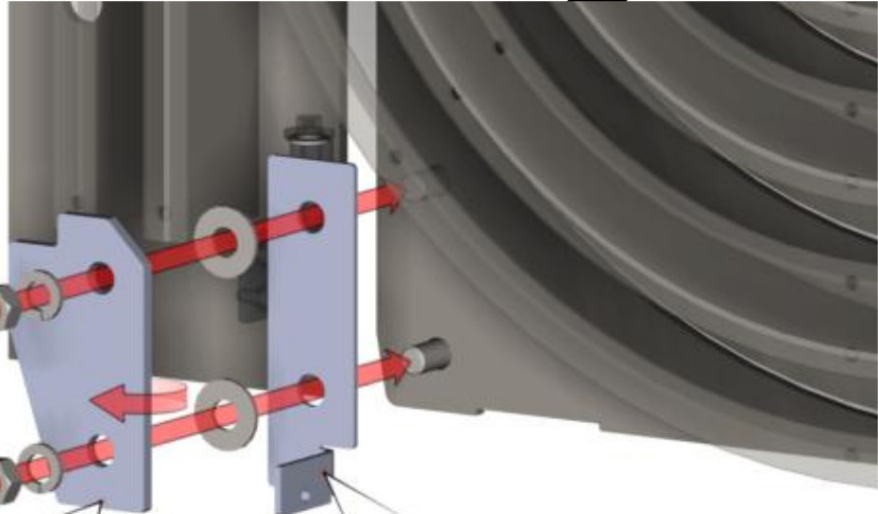
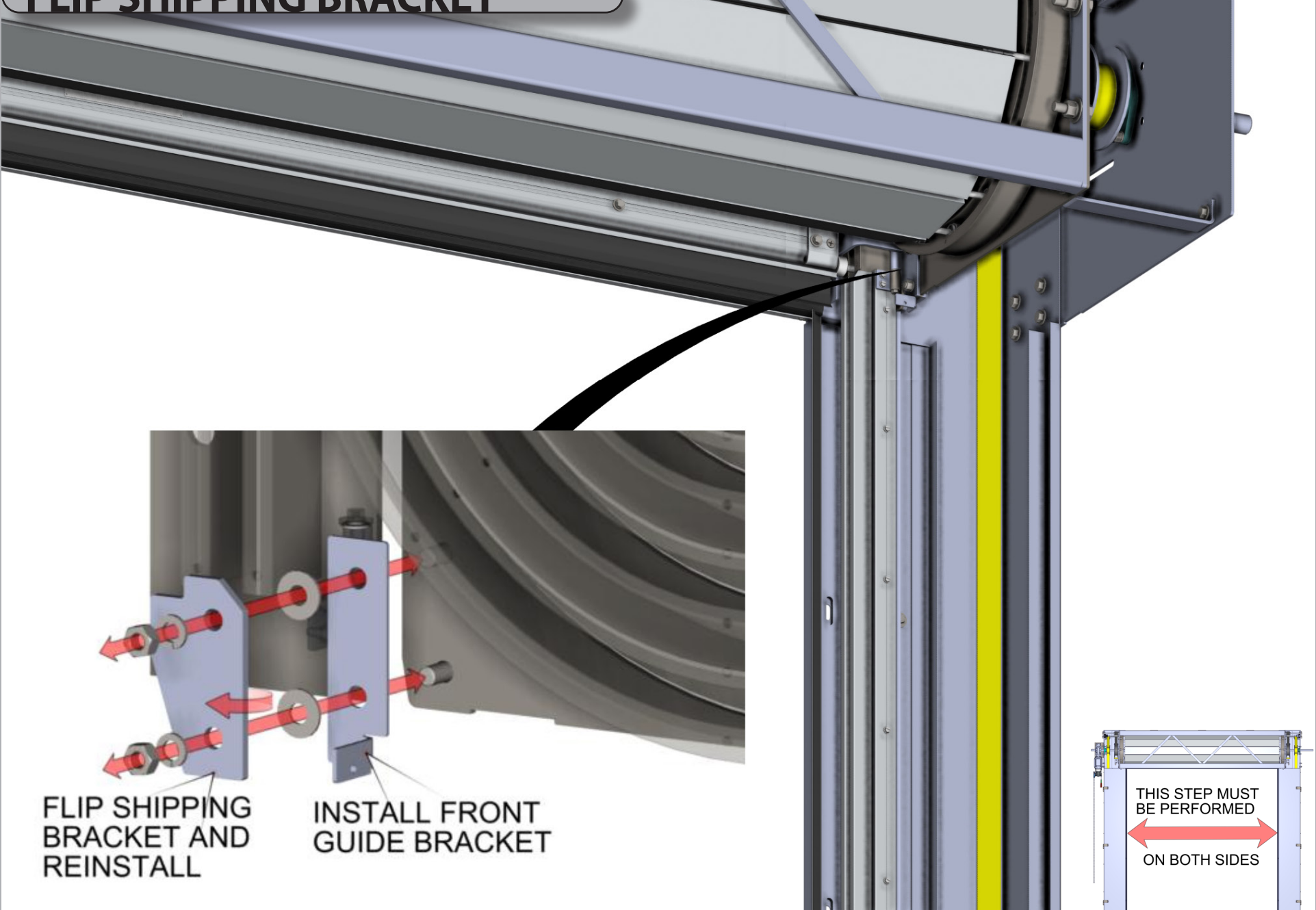

FLIP SHIPPING BRACKET AND REINSTALL

INSTALL FRONT GUIDE BRACKET

THIS STEP MUST BE PERFORMED ON BOTH SIDES

SECTION 3 - FIRST MANUAL DOOR OPERATION

CHECKLIST AND MANUAL DOOR LOWERING

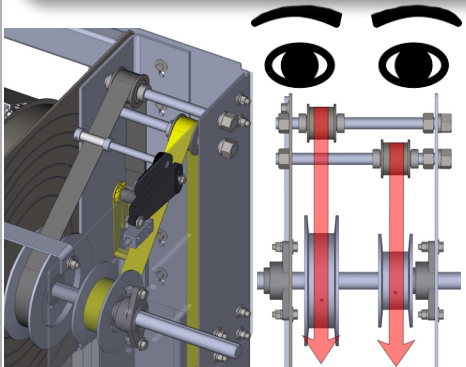

STANDARD CONFIGURATION

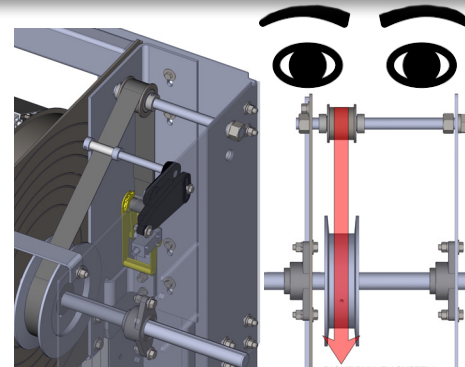

SLIM GUIDE CONFIGURATION

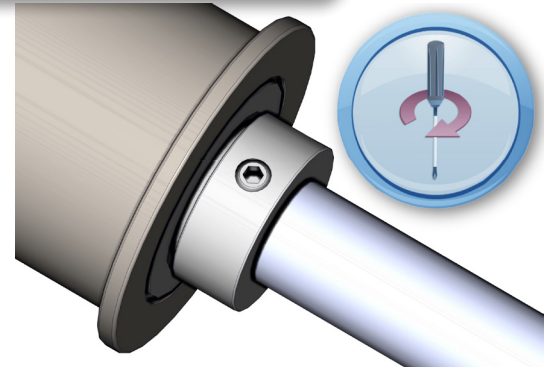

NOTE: Tighten all set screws in set collars and bearings.

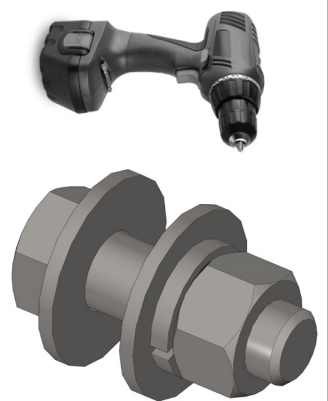

NOTE: Check and tighten all nuts and bolts.

NOTE: Double check belts. Be sure they are tight and properly aligned.

1

2

3

NOTE: While lowering the door look and listen for smooth operation.

6

NOTE: Lower the door with the hand chain.

5

NOTE: Be sure all equipment and personnel are clear of the door opening.

4

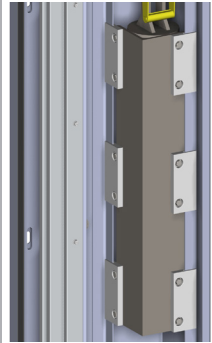

NOTE: With standard configuration, be sure the counterweight sliders are engaged in the alignment track the entire path up.

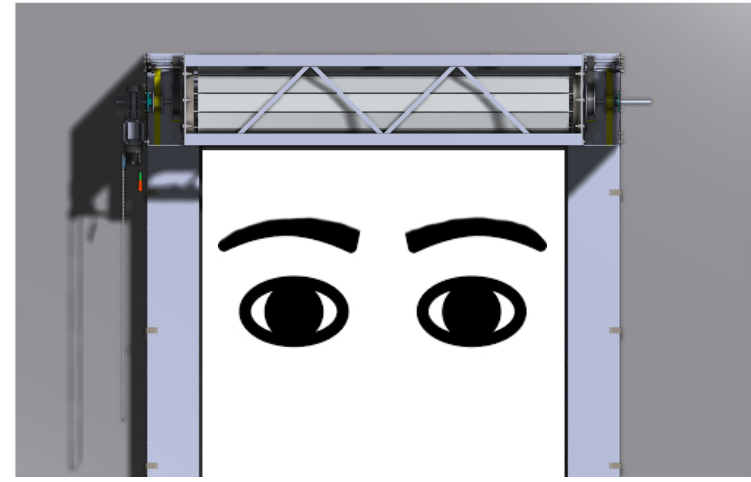
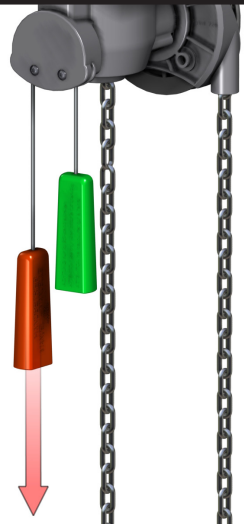

SECTION 3 - FIRST MANUAL DOOR OPERATION

CHECK AND ADJUST

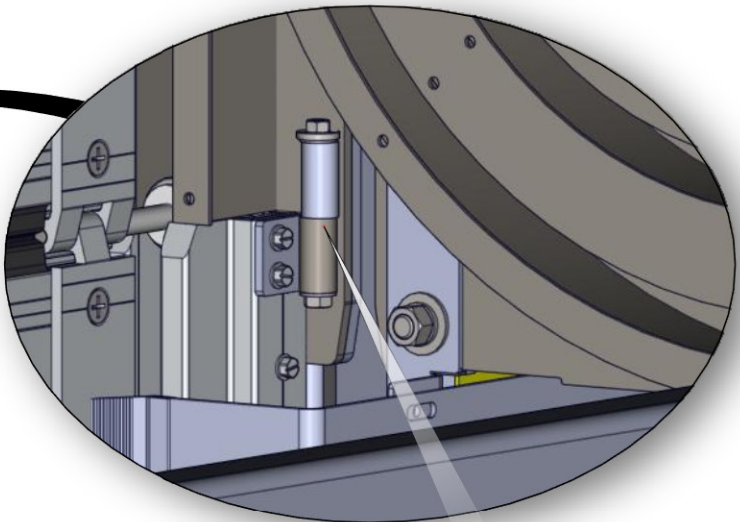
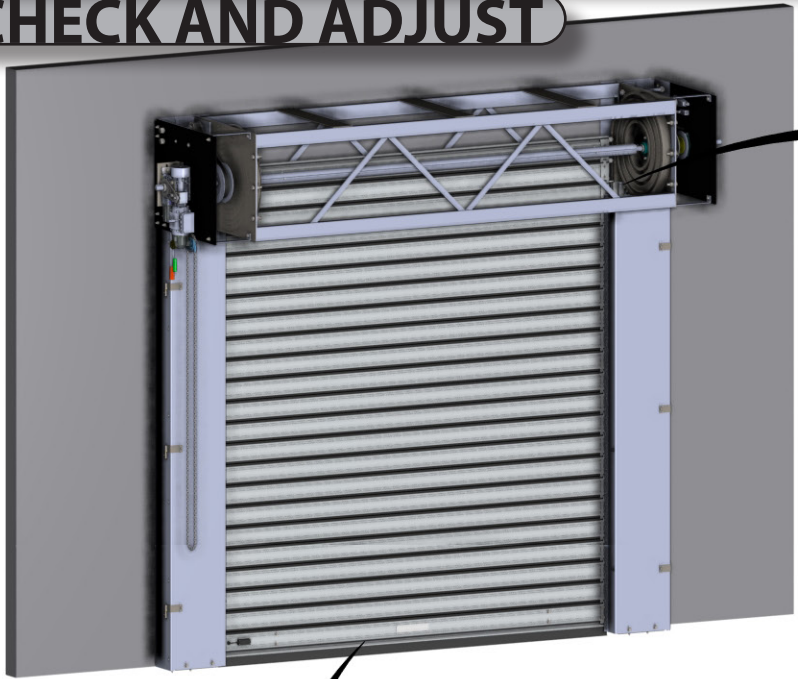

TIGHTEN ALIGNMENT PIN



LASER LEVEL LINE

NOTE: After leveling the curtain install belt clamps on drive belts above ratchet, as shown on page 17.

NOTE: Clamp the belt clamps as close to the ratchet as possible.

NOTE: Check that the curtain is level using a laser level. If you do not have a laser you can use a tape measure on both sides to ensure level. Adjust ratchets to achieve level.

CAUTION

A level curtain is critical for proper operation of the door. Continuing to use a door with an improperly leveled curtain could cause serious damage to the product.

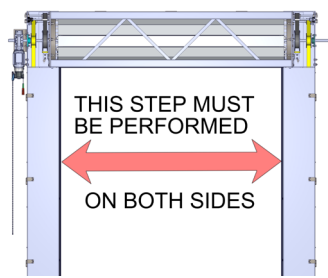

THIS STEP MUST BE PERFORMED ON BOTH SIDES

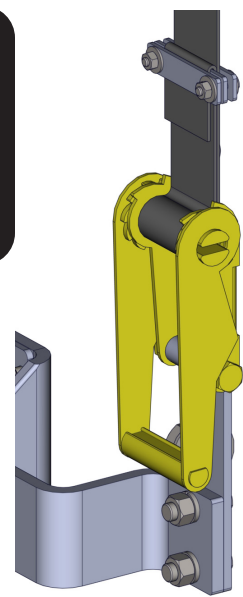

SECTION 4 - ELECTRONIC

INSTALL ELECTRONIC COMPONENTS

NOTE: Install the junction box near the motor using fasteners appropriate for your jamb material.



NOTE: Install control panel at eye level on the motor side using fasteners appropriate for your jamb material. Mounting holes are located inside the panel.

NOTE: Refer to the electronics manual for your VFD motor and control panel 827805. Follow all instructions and warnings.



SECTION 5 - TENSION SENSOR ADJUSTMENT

IMPORTANT: THE DOOR MUST BE PROPERLY BALANCED AND FUNCTIONAL PRIOR TO TENSION SENSOR ADJUSTMENT.

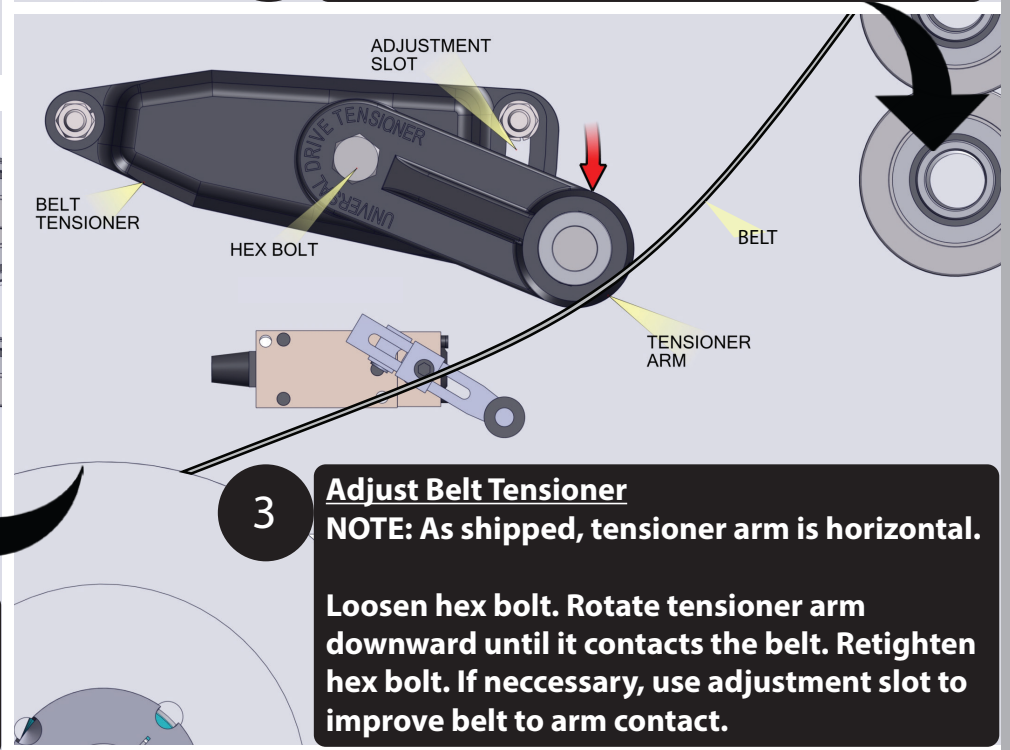
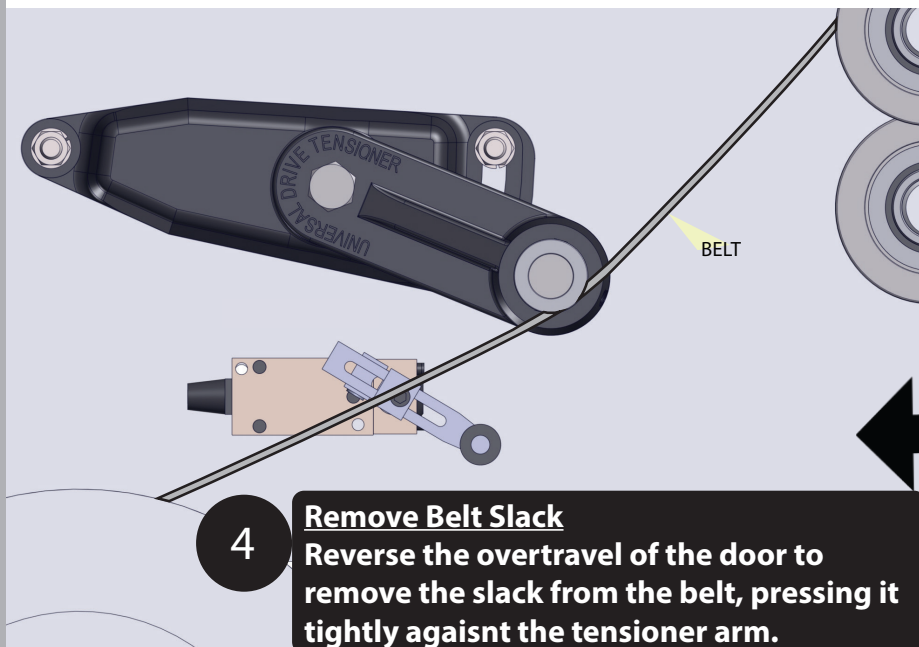
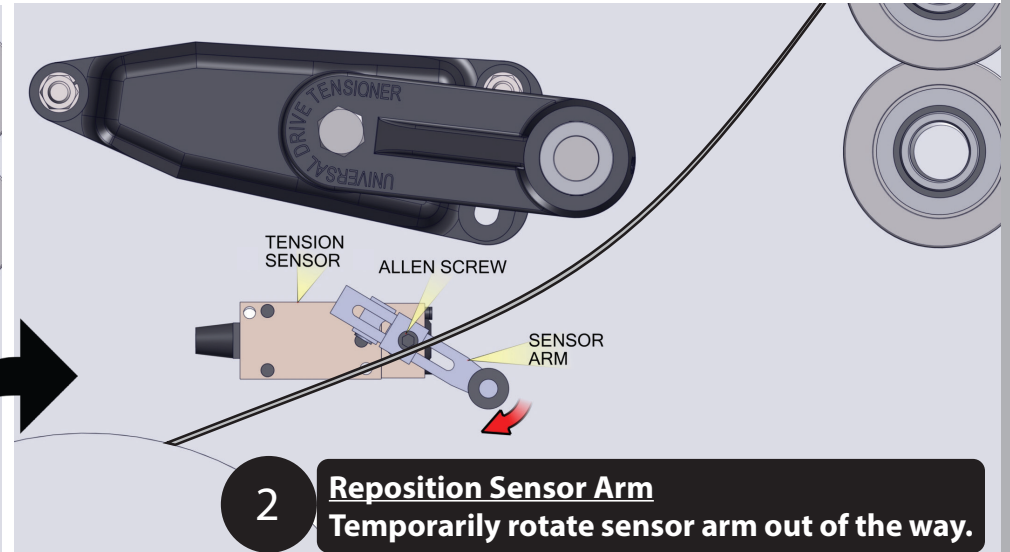
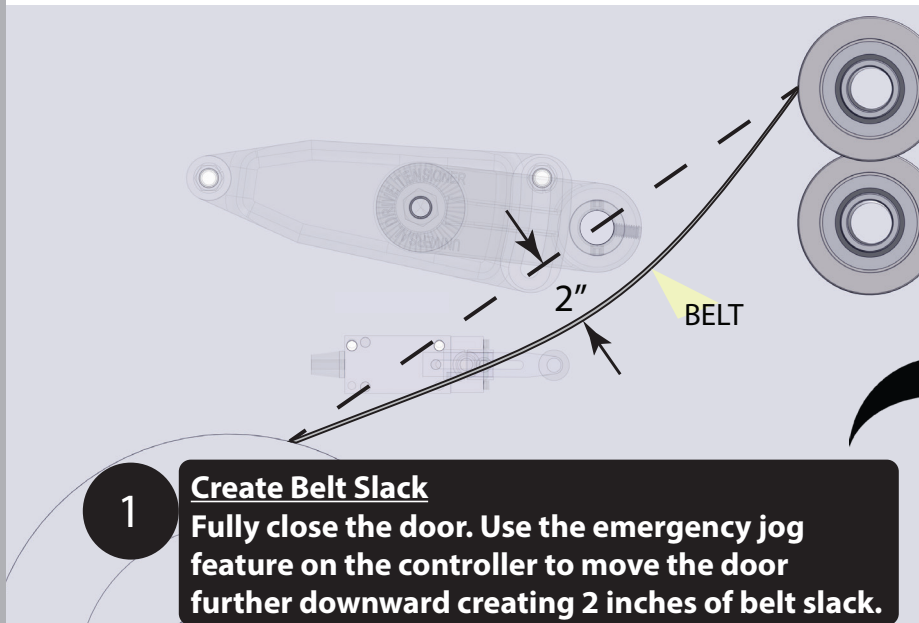

SECTION 5 - TENSION SENSOR ADJUSTMENT

5 **Cycle The Door** two full cycles to verify constant contact between belt and tensioner arm. Notice the tensioner arm's normal range of motion.

6 **Adjust Sensor Arm** into position, slightly beyond the tensioner arm's normal range of motion.

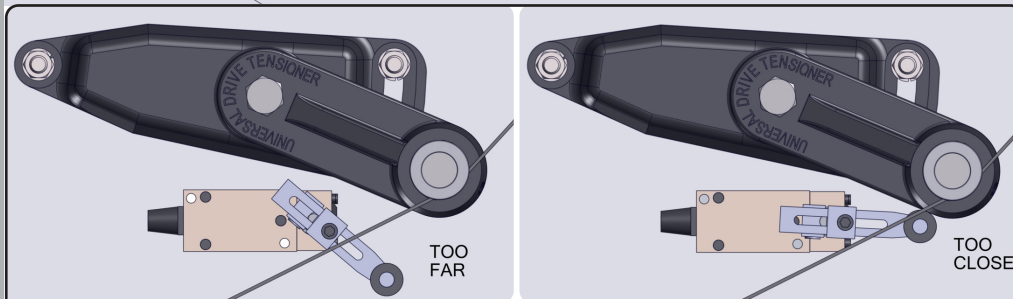
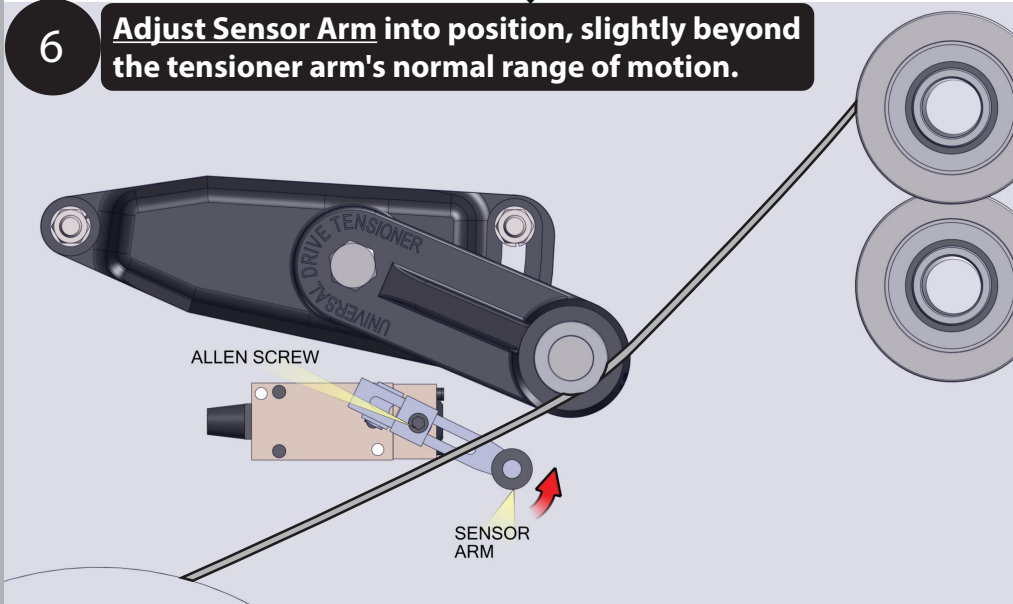

EXAMPLES OF HOW NOT TO DO IT

7 **Cycle The Door Again** one full cycle to confirm the tensioner arm does not contact the sensor arm during normal operation. (Confirm no "false positives")

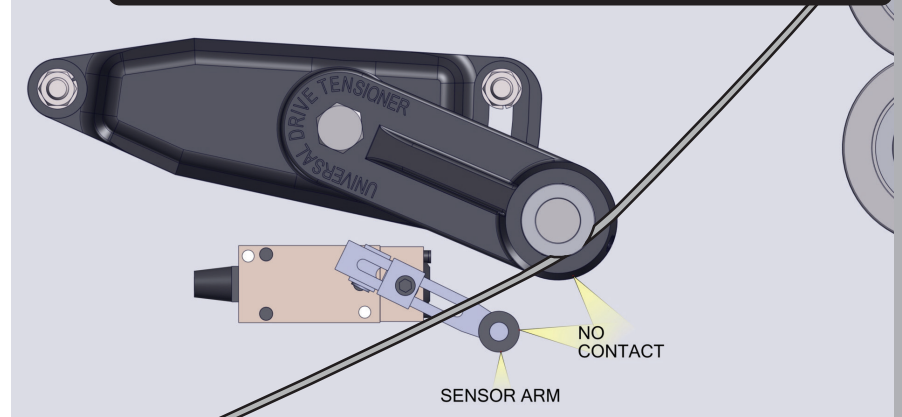

8 **Test Sensor**
Overtravel the door downward to simulate loss of belt tension. Check inputs 4 and 5 on the control panel. If sensor trips, proceed to Step 9. If not, repeat Steps 6 and 7.

9 **Reverse the overtravel** of the door to return tension to the belt for normal operation.

10 **Repeat Steps 1 through 9** for opposite side.

NOTE: New drive and counterbalance belts will stretch after a period of several days. This is normal, and may cause the tension sensor to trigger an E32 Tension Switch Active message on the controller. If this occurs, tighten the belts using the ratchets and test for proper contact.

WARNING

The belt tensioners and tension sensors are necessary to ensure safe operation of the door. The belt tensioner should always be set to make contact with and trigger the tension sensor when belt tension is lost.

SECTION 6 - FINAL INSTALLATION STEPS

INSTALL FINAL ITEMS

NOTE: Install covers and hood (some non-standard items shown). If hood will be used it should be installed first.

NOTE: Apply safety labels

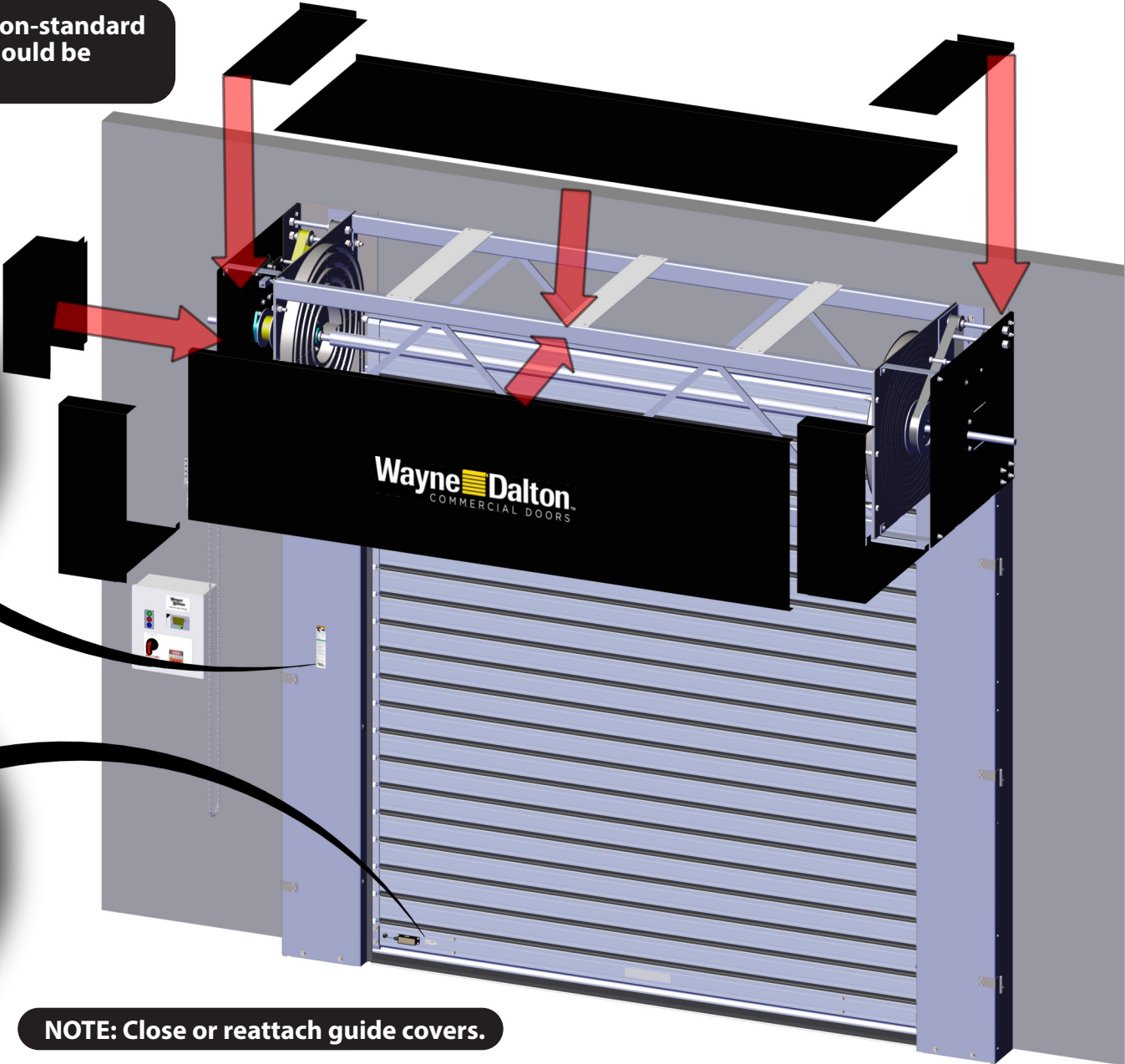

NOTE: Close or reattach guide covers.

SECTION 7 - BREAKDOWN OF PARTS

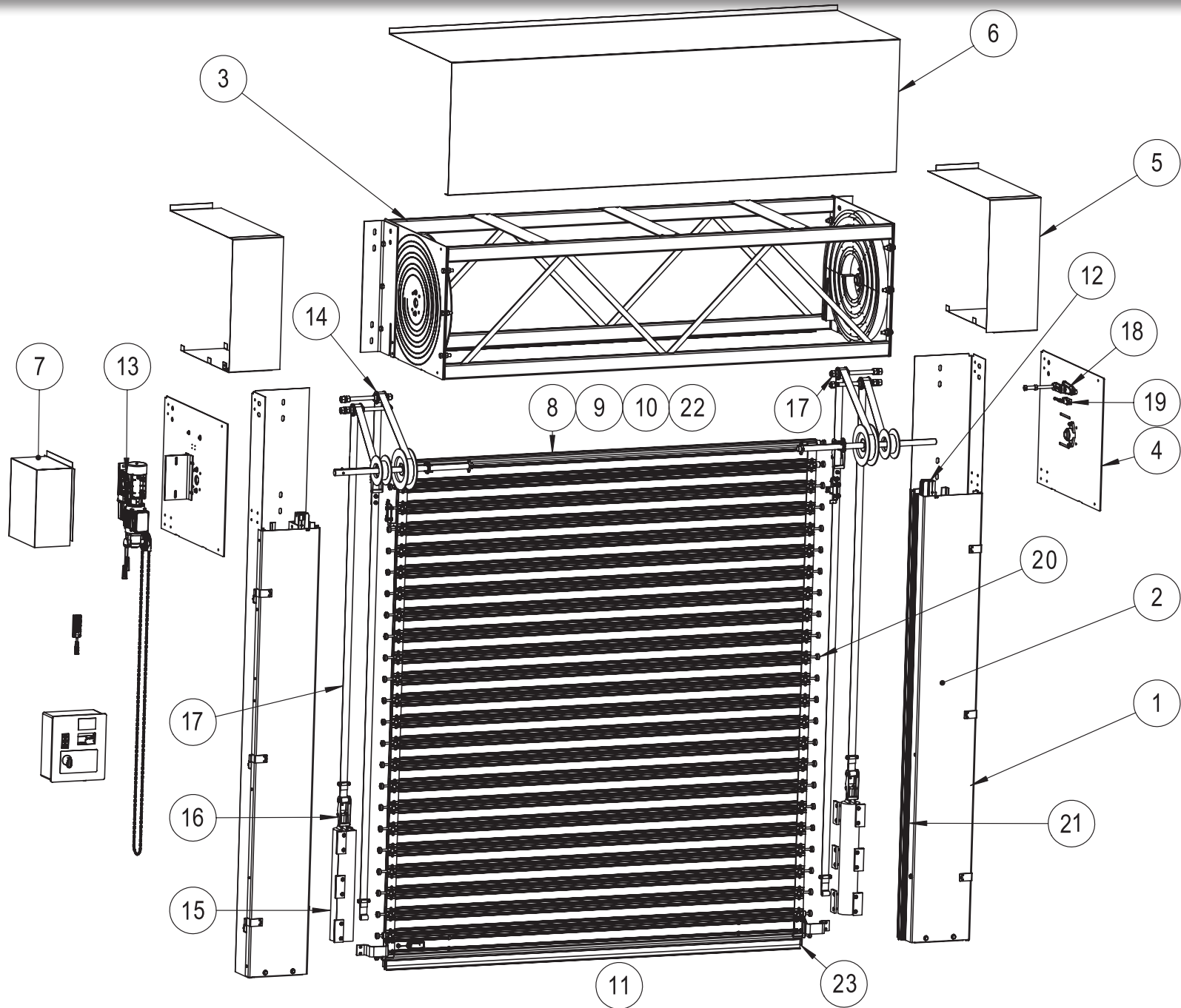

SECTION 7 - BREAKDOWN OF PARTS

TABLE OF PART NUMBERS

Item	Description	Part Number
1	Wall Guide Assembly - One side only	920963
2	Front Guide Assembly - One side only	920964
3	Header/Curtain Assembly - Part 1 of 2 (must order Parts 1 and 2 together)	920991
	Header/Curtain Assembly - Part 2 of 2 (must order Parts 1 and 2 together)	920992
4	Head Plate Assembly - Side Plate RH/LH, related hardware (Select: Standard or Large)	827016.0001 Standard LH 827315.0001 / Large LH 827315.0002 Standard RH 827315.0011 / Large RH 827315.0012
5	Head Plate Cover	920983
6	Hood	920984
7	Operator Cover	920985
8	Top Slat Assembly	920986
9	Intermediate Slat	920987
10	Intermediate Slat Vision (Perforated & Laxan)	920988
11	Bottom Slat Assembly	920989
12	Extruded Track	920965
13	Motor	920993
13	Motor	920993
14	Counterweight	920994
15	Counter Weight HW Kit	827017.0001
16	Counter Weight Belts	827330.0002
17	Idler Pulley Kit	827018.0001
18	Belt Tensioner Kit	827019.0001
19	Tensioner Sensor	827020.0001
20	Roller Assembly	827021.0001
21	UHMW Bumpers	827416
22	Seal Between Slats	827692.0002
23	Light Curtain	827022.0001



ADV-X High Speed Metal Doors Models 888 and 889

Limited Warranty

Wayne Dalton ("Seller") warrants to the original purchaser of the high speed metal door models 888 ADV-X and 889 ADV-X ("Product"), subject to all of the terms and conditions hereof, that the Product and all components thereof will be free from defects in materials and workmanship under normal use for the following period, measured from the date of installation:

- **For Models 888 ADV-X and 889 ADV-X, Seller warrants all mechanical door system components and the control panel hardware for a period of 60 MONTHS**

Seller's obligation under this warranty is specifically limited to repairing or replacing, at its option, any part which is determined by Seller to be defective during the applicable warranty period. Repair or replacement labor for any defective Product part or component is included for a period of one (1) year from the date of installation. After that, any labor charges are excluded and will be the responsibility of the purchaser.

This warranty is made to the original purchaser of the Product only, and is not transferable or assignable. This warranty does not apply to any unauthorized alteration or repair of the Product, or to any Product or component which has been damaged or deteriorated due to misuse (including used of interior rated products in exterior applications), neglect, accident, failure to provide necessary maintenance, normal wear and tear, or acts of God or any other cause beyond the reasonable control of Seller. This warranty does not cover replacement batteries or apply to any damage or deterioration caused by exposure to salt water, chemical fumes or other corrosive or aggressive environments, whether naturally occurring or man-made, including, but not limited to, environments with a high degree of humidity, sand, dirt or grease.

THIS WARRANTY IS EXCLUSIVE AND IN LIEU OF ANY OTHER WARRANTIES, EITHER EXPRESS OR IMPLIED, INCLUDING BUT NOT LIMITED TO ANY IMPLIED WARRANTY OF MERCHANTABILITY OR FITNESS FOR A PARTICULAR PURPOSE.

IN NO EVENT SHALL SELLER BE RESPONSIBLE FOR, OR LIABLE TO ANYONE FOR, SPECIAL, INDIRECT, COLLATERAL, PUNITIVE, INCIDENTAL OR CONSEQUENTIAL DAMAGES, even if Seller has been advised of the possibility of such damages. Such excluded damages include, but are not limited to, loss of goodwill, loss of profits, loss of use, cost of any substitute product, interruption of business, or other similar indirect financial loss.

Claims under this warranty must be made promptly after discovery, within the applicable warranty period, and in writing to the Seller or to the authorized distributor or installer whose name and address appear below. The purchaser must allow Seller a reasonable opportunity to inspect any Product claimed to be defective prior to removal or any alteration of its condition. Proof of the purchase and/or installation date, and identification as the original purchaser, may be required.

DOOR MODEL: _____

ORIGINAL PURCHASER: _____

INSTALLATION ADDRESS: _____

DEALER: _____

DEALER'S ADDRESS: _____

FACORY ORDER #: _____

DATE OF INSTALLATION: _____

SIGNATURE OF DEALER: _____