

READ THESE  
INSTRUCTIONS  
THOROUGHLY  
BEFORE  
ATTEMPTING  
TO INSTALL THIS  
DOOR!

Product may be covered by one or more patents.  
See [www.wayne-dalton.com/patents](http://www.wayne-dalton.com/patents) for details.

# TABLE OF CONTENTS

<b>Section 1 - Safety information .....</b>	<b>3-4</b>
<b>Section 2 - General information .....</b>	<b>5-8</b>
<b>Section 3 - Door installation .....</b>	<b>9-19</b>
<b>Section 4 - Low voltage wiring (3 Phase controller) .....</b>	<b>20-25</b>
<b>Section 5 - High voltage wiring (3 phase controller) .....</b>	<b>26-29</b>
<b>Section 6 - Initial startup procedure (3 phase) .....</b>	<b>30-31</b>
<b>Section 7 - Menus (3 phase controller).....</b>	<b>32-39</b>
<b>Section 8 - Troubleshooting.....</b>	<b>40-45</b>
<b>Section 9 - Low voltage wiring (single phase control)..</b>	<b>46-48</b>
<b>Section 10 - High voltage wiring (single phase).....</b>	<b>49-52</b>
<b>Section 11 - Initial startup procedure (single phase) .....</b>	<b>53</b>
<b>Section 12 - Menus (Single phase controller) .....</b>	<b>54-63</b>
<b>Section 13 - Troubleshooting (Single phase) .....</b>	<b>64</b>
<b>Section 14 - Service and maintenance .....</b>	<b>65</b>
<b>Section 15 - Illustrated Parts Breakdown .....</b>	<b>66-67</b>
<b>Warranty.....</b>	<b>68</b>

# SECTION 1 - SAFETY INFORMATION

## OVERVIEW OF POTENTIAL HAZARDS READ THIS SAFETY INFORMATION

### ⚠ WARNING

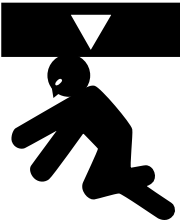

Advanced Performance service doors are large, heavy objects that move with the help of electric motors. Since moving objects and electric motors can cause injuries, your safety and the safety of others depends on you reading the information in this manual. If you have any questions or do not understand the information presented, you should consult a licensed professional

In this section and those that follow, the words "**DANGER**", "**WARNING**", and "**CAUTION**" are used to stress important safety information. The word:

- ⚠ **DANGER** indicates an imminently hazardous situation which, if not avoided, will result in death or serious injury.
- ⚠ **WARNING** indicates a potentially hazardous situation which, if not avoided, could result in death or serious injury.
- ⚠ **CAUTION** indicates a potentially hazardous situation which, if not avoided, may result in injury or property damage.

The word **NOTE** is used to indicate important steps to be followed or important considerations.

1. Read manual and warnings carefully.
2. Keep the door in good working condition.
3. This door is equipped with a sensing edge, check sensing edge operations daily. Make any necessary repairs to keep it functional.
4. All models are equipped with an overcurrent device. This must be manually reset following an overcurrent condition.
5. Keep instructions in a prominent location near the Control Panel.

POTENTIAL HAZARD	EFFECT	PREVENTION
 <p><b>MOVING DOOR</b></p>	<p>⚠ <b>WARNING</b> <b>Can Cause Serious Injury or Death</b></p>	<p><b>Do NOT</b> operate unless the doorway is in sight and free of obstructions. Keep people clear of opening while door is moving.</p> <p><b>Do NOT</b> change control to momentary contact unless an external reversing means is installed.</p> <p><b>Do NOT</b> operate a door that jams.</p>
 <p><b>ELECTRICAL SHOCK</b></p>	<p>⚠ <b>WARNING</b> <b>Can Cause Serious Injury or Death</b></p>	<p>Turn <b>OFF</b> electrical power before removing Control Panel or motor cover.</p> <p>When replacing Control Panel cover make sure wires are <b>NOT</b> pinched or near moving parts.</p> <p>Operator must be electrically grounded.</p>

## SECTION 1 - SAFETY INFORMATION (continued.....)

### SAFETY INSTRUCTIONS

#### ***Electrical Power Requirements for all ADV-X Door Models***

ADV-X models 880 and 881 are available in single phase and 3-phase voltages. Single phase voltages are available in 110-120VAC and 220-240VAC. 3 phase voltages are available in 240VAC, 480VAC, and 575VAC. ADV-X model 882, 883, 884, and 885 are available in 3 phase voltages only. It is recommended to use the highest voltage available. 3 phase is recommended. **YOUR LOCAL CODES MAY REQUIRE THAT THE INCOMING POWER TO YOUR DOOR HAVE A LOCK-OUT / TAG-OUT EQUIPPED FUSED DISCONNECT SWITCH (TO BE FURNISHED BY OTHERS) WITHIN EYESIGHT TO THE DOOR'S CONTROL PANEL.** Incoming power wiring must meet all NEC and local building codes and use the proper wire gauge size for the control panel's amperage rating on the nameplate. To reduce the risk of electric shock, the chassis of the control panel must be properly grounded.

For 208VAC power: Site evaluations are required for 208VAC power. 230VAC doors are designed to run on 207-253VAC power. If the measured voltage is 208VAC or lower, use of a buck-boost transformer is required. (3 phase # 500394-100X, single phase # 500290-0005)

#### **CAUTION**

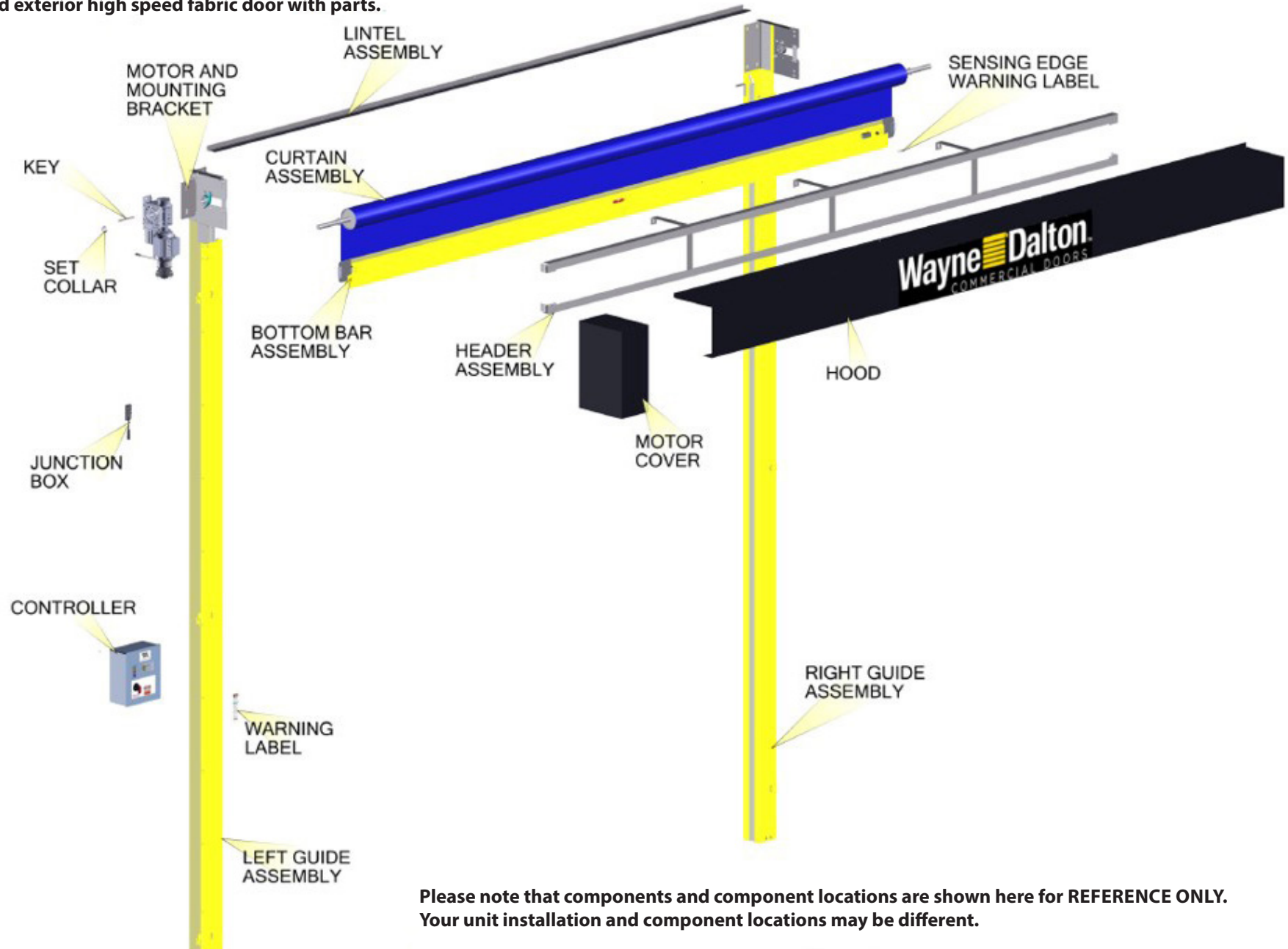
ADV-X Door Models must be supplied by a properly grounded voltage supply, e.g. 220/240 VAC 1-phase or 208/230/460/575 VAC 3-phase. Floating (Open Delta) ungrounded voltage supply sources should not be used. For 480 VAC, 240 VAC or 120 VAC unbalanced Delta systems should **NOT** be used. Voltage unbalance is a common occurrence on Delta supply systems, which power both single phase and three phase loads, which can lead to unequal voltages on each phase leg. Voltage unbalance can cause deterioration of motor performance, such as loss of torque, overheating, decreases in the winding insulation life, and can cause motor starter contacts on the control panel to permanently "weld" closed. Voltage unbalance can be caused by inadequate conductor sizing, Delta transformer sizing, excessive single-phase loads, poor grounding, or intermittent high resistance faults which may cause destructive over-voltages to occur.

***Overhead Door Corporation's warranty will not cover damage caused by failure of the motor, control panel or other electrical components due to the use of an inadequately grounded system.***

## SECTION 2 - GENERAL INFORMATION

### COMPONENT IDENTIFICATION DRAWING WITH STANDARD HOOD

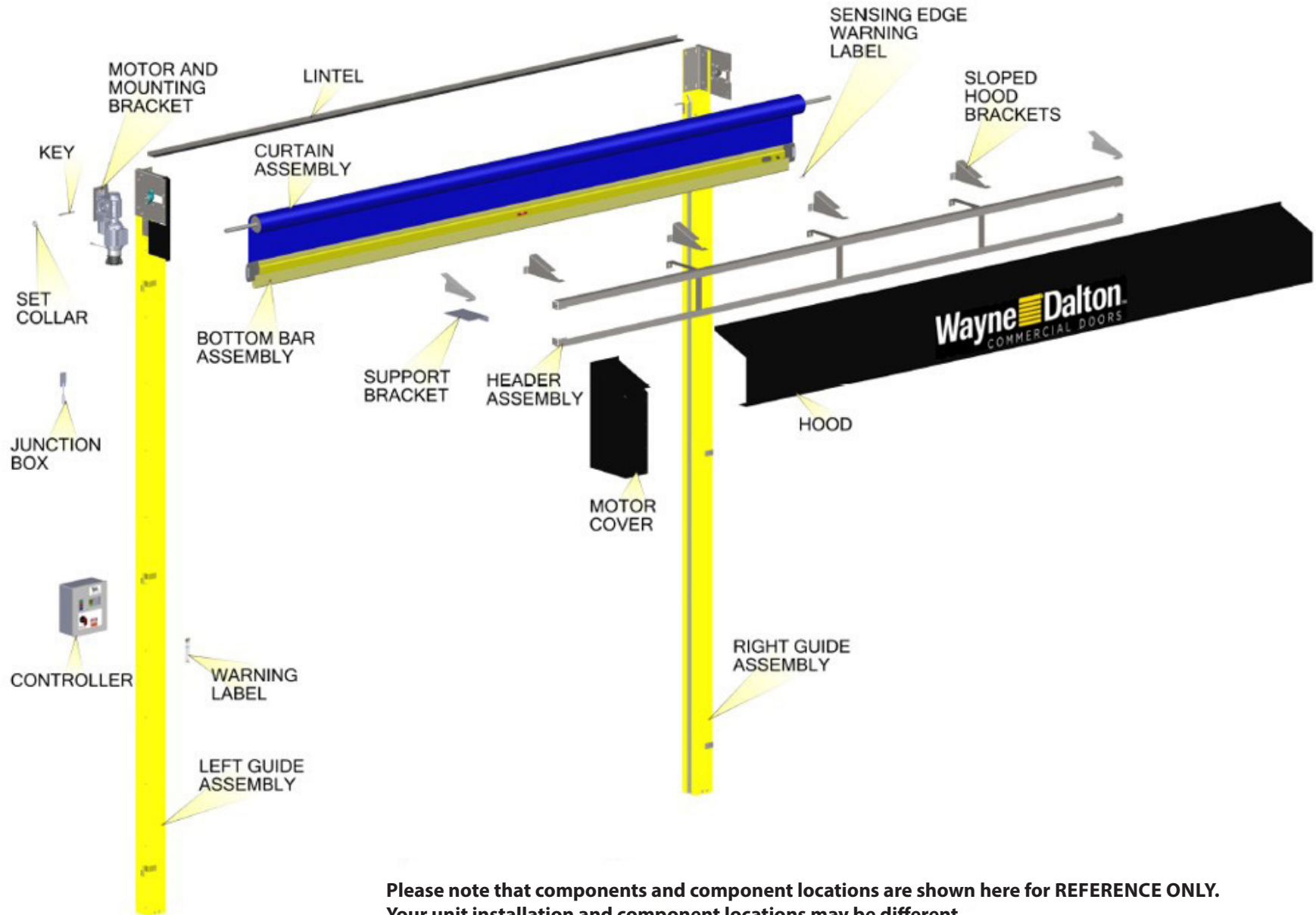
Strutted exterior high speed fabric door with parts.



## SECTION 2 - GENERAL INFORMATION (continued....)

### COMPONENT IDENTIFICATION DRAWING WITH SLOPED HOOD

Strutted exterior high speed fabric door with parts.



Please note that components and component locations are shown here for REFERENCE ONLY. Your unit installation and component locations may be different.

# SECTION 2 - GENERAL INFORMATION (continued....)

## DOOR INSTALLATION DATA SHEET

A sample of the "DOOR INSTALLATION DATA" sheet is shown here. Locate the work order "Door Installation Data" sheet inside the door hardware box. You will need to refer to the "Door Installation Data" sheet. See Figure 2.  
 Factory order number on door components must match with factory order number on the "Door Installation Data" sheet. Each door has it's own individual sheet.

Jobless Traveler Report

SO#	SO Line#:	SO Line Item:
Org Code:	Qty:	Desc:
Cust. PO:	Customer:	Customer Job:
Job Name:		
Schl'd Ship Dt:		
Product Desc:		

CURTAIN:  
 OPERATION:  
 BOTTOM BAR:  
 GUIDE:

HOOD/CRATE:

*****	DOOR	INSTALLATION	DATA#	*****	*****	*****
MODEL:				REFERENCE:		
OPENING WIDTH:		OPENING HEIGHT:		TYPE OF OPERATION:		GUIDE TYPE:
INITIAL TURNS:		RELEASE TURN:		OPERATION TYPE:		CURTAIN/BOTTOM BAR WT:
TOTAL TURNS:		OPER MODEL: / VOLTAGE:		DRIVE NO:		PIPE ASSEMBLY WT:
GUIDE GAP:		OPER MOUNT TYPE:		GUIDE FINISH:		BRACKET FINISH:
***** WORK ORDER MESSAGES *****						
**						
**						
**						

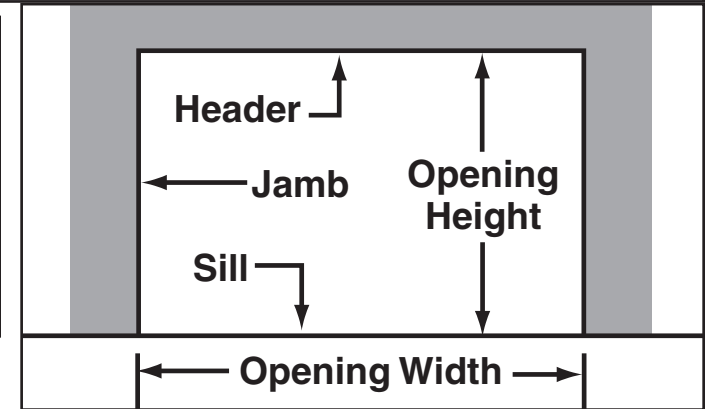
**Fig 2**

## SECTION 2 - GENERAL INFORMATION (continued....)

### PRE-INSTALLATION CHECK LIST

Verify that the door installation can be accomplished before proceeding:

- Locate the work order "DOOR INSTALLATION DATA" sheet, see Figure 2, inside the door hardware box.
- Does the wall opening shown in FIG 3 match the Opening Width and Height shown on the "Door Installation Data" sheet?
- Can the guides be installed plumb?
- Check the sill for level. If sill is not level, mark the high sill location on the low side jamb.
- Guides are designed to rest on sill.
- Does the "G" dimension on your "DOOR INSTALLATION DATA" sheet match your opening width. See FIG 4



**Fig 3**



**Fig 4**



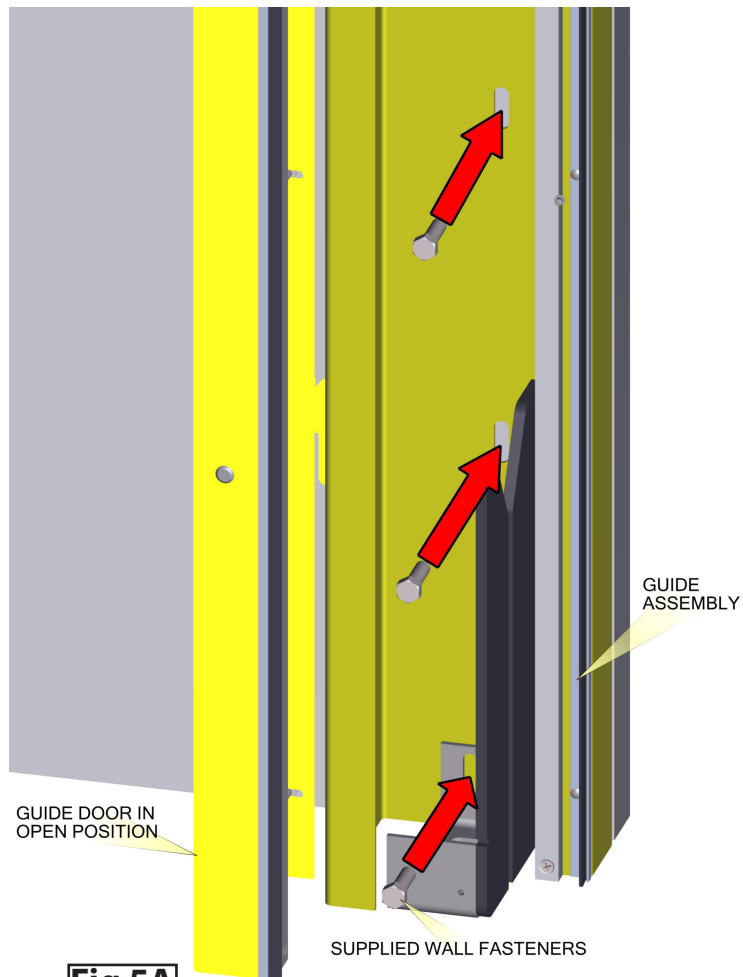
# SECTION 3 - DOOR INSTALLATION

## ⚠ WARNING

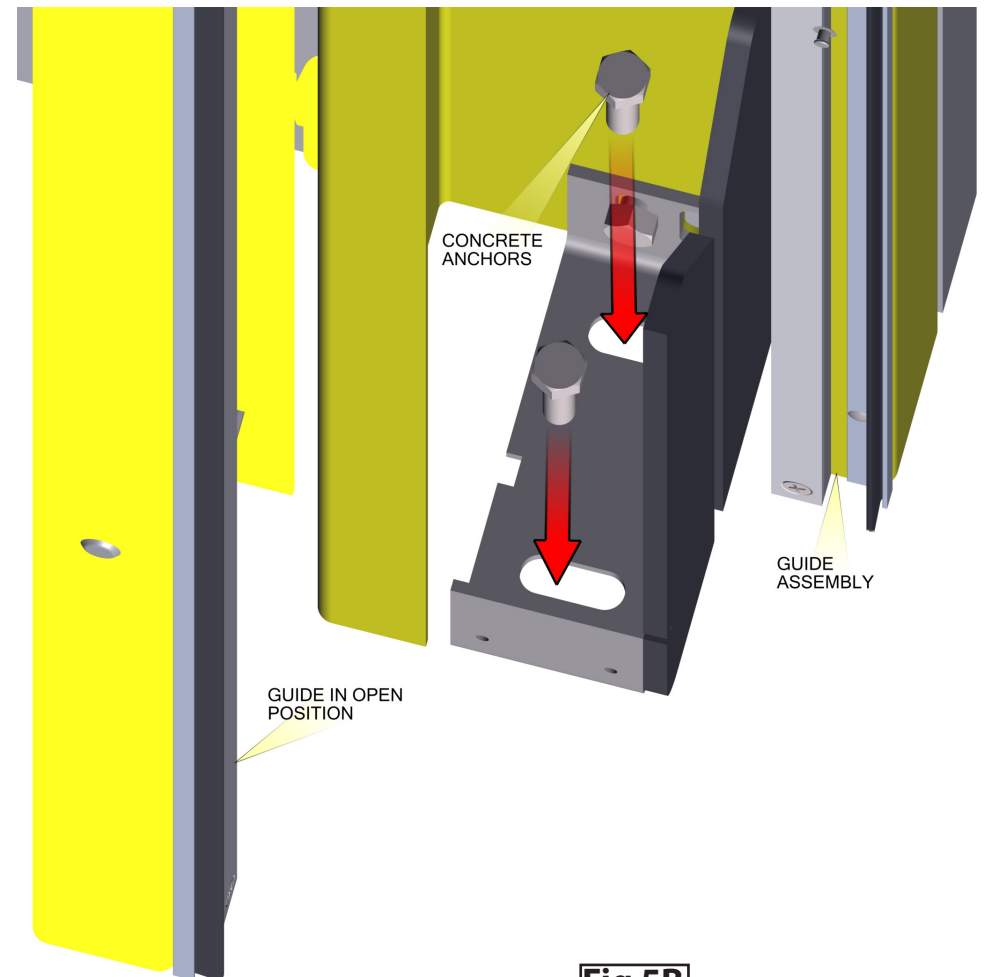
Follow instructions and use proper lifting equipment and correct lifting procedure to avoid serious injury or death.

### STEP 1 INSTALL GUIDES

- Check "G" Dimension as illustrated in Fig 4 on page 5. "G" Dimension must match your "DOOR INSTALLATION DATA" sheet.
- Ideally your "G" dimension will exactly match your opening width. If it does not you must mount your guides so the "G" dimension is held over the entire height.
- Open hinged guides and mount to the wall surface using supplied fasteners. See FIG 5A.
- Check "G" Dimension as illustrated in Fig 4 on page 5. "G" Dimension must match your "DOOR INSTALLATION DATA" sheet.
- Both guides MUST be on a level line and both guides MUST be plumb.
- The "G" Dimension must be held within 1/8" over the entire height of the guides.
- Install the concrete anchors through the floor bracket, securing the guides to the floor. See FIG 5B



**Fig 5A**

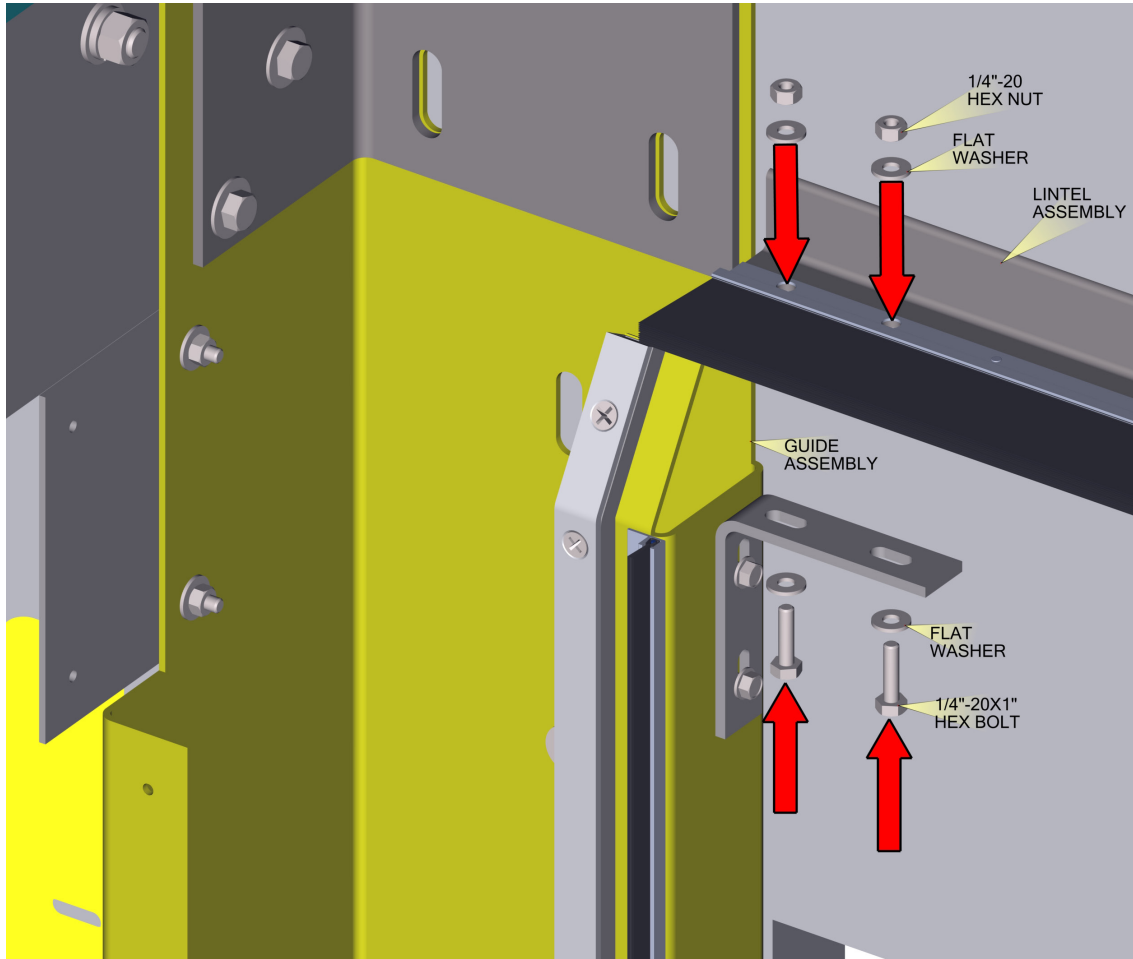


**Fig 5B**

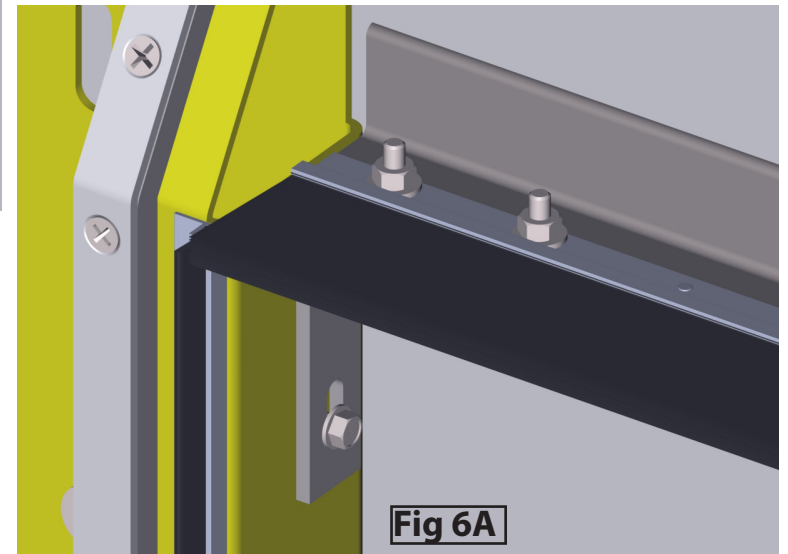
## SECTION 3 - DOOR INSTALLATION (continued....)

### STEP 2 INSTALL LINTEL ASSEMBLY

- Attach the lintel assembly to the bracket on each headplate, as shown in FIG 6 AND FIG 6A.

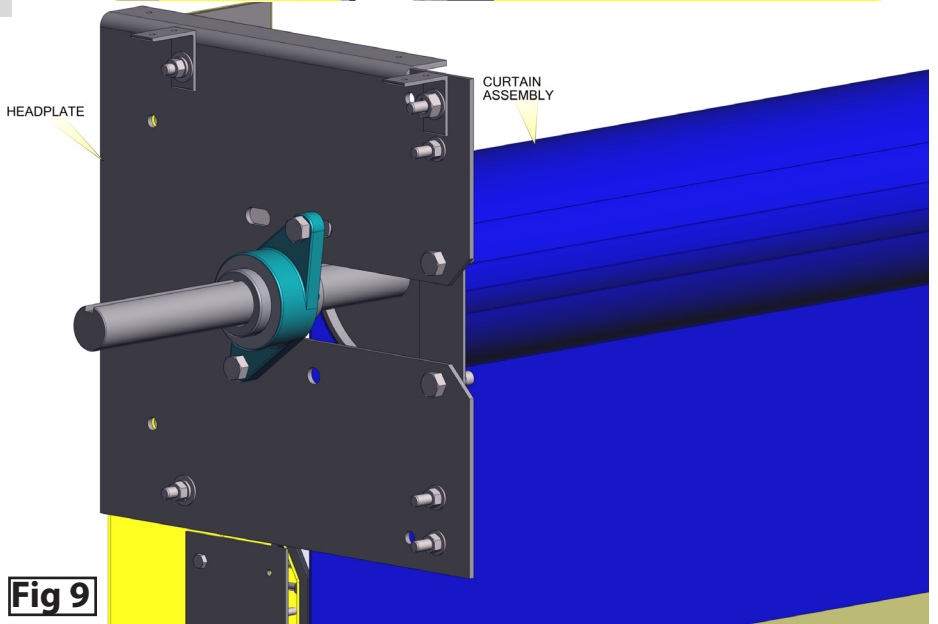
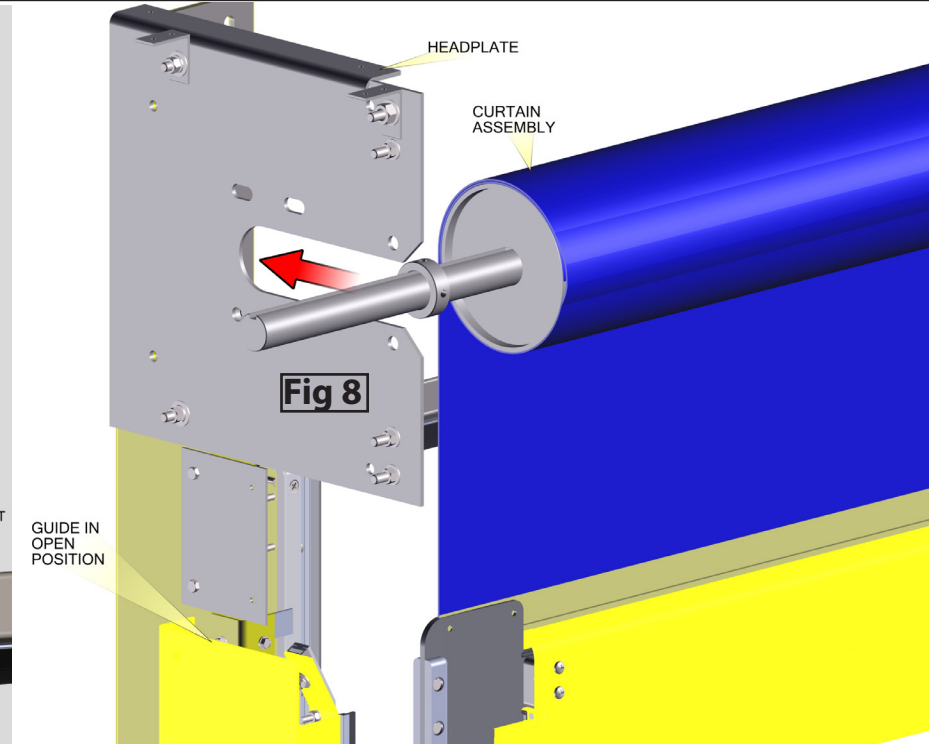
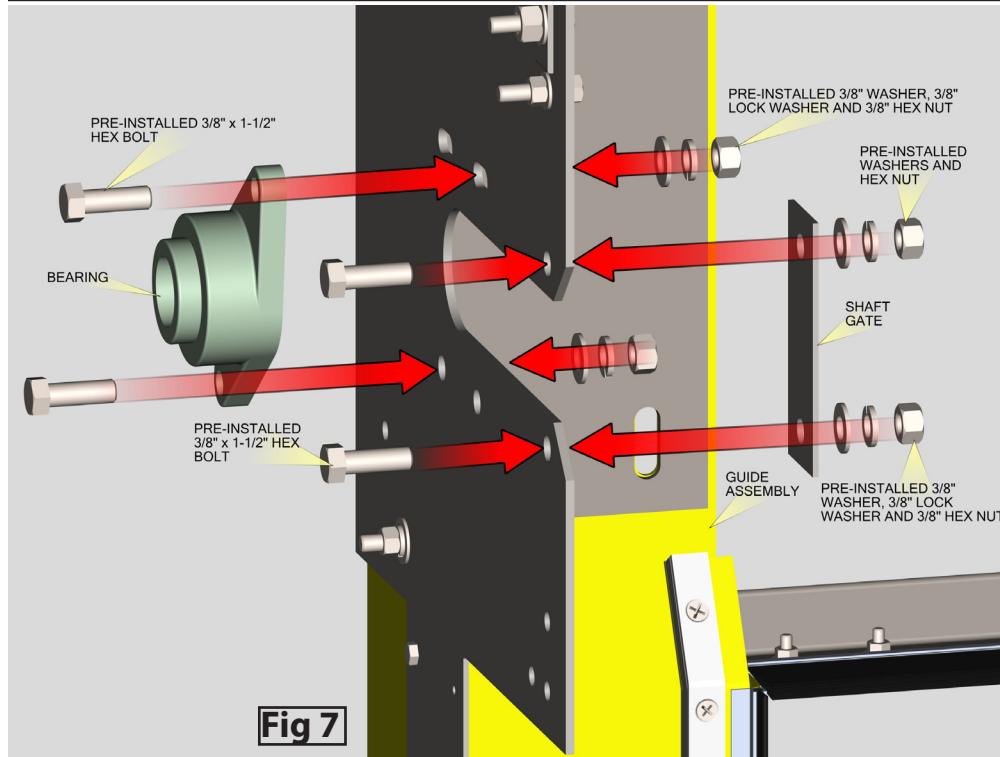


**Fig 6**



**Fig 6A**

## SECTION 3 - DOOR INSTALLATION (continued....)



### **⚠ WARNING**

Rapidly closing curtain could result in death or serious injury. Do not remove factory banding around curtain assembly until step 5.

### **⚠ WARNING**

Follow instructions and use proper lifting equipment and correct lifting procedure to avoid serious injury or death.

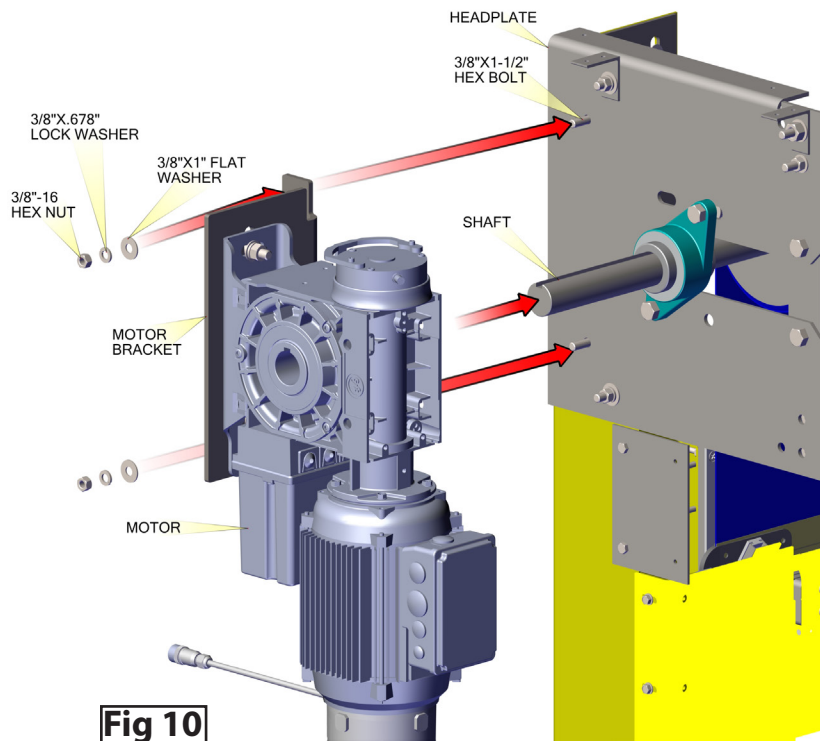
### **STEP 3 INSTALL CURTAIN ASSEMBLY**

- Remove pre-installed bearings and shaft gates from both headplates, as shown in FIG 7.
- Lift the curtain assembly using a fork lift or other appropriate lifting equipment and slide it into the slots in the headplates, as shown in FIG 8.
- Before removing the forklift or supporting equipment, reinstall the bearings by sliding them onto the shaft and attaching them to the headplates. Also reinstall the shaft gates to the headplates. See FIG 9.
- Only hand tighten the nuts onto the bolts of the bearings as you will need to make adjustments before final tightening.

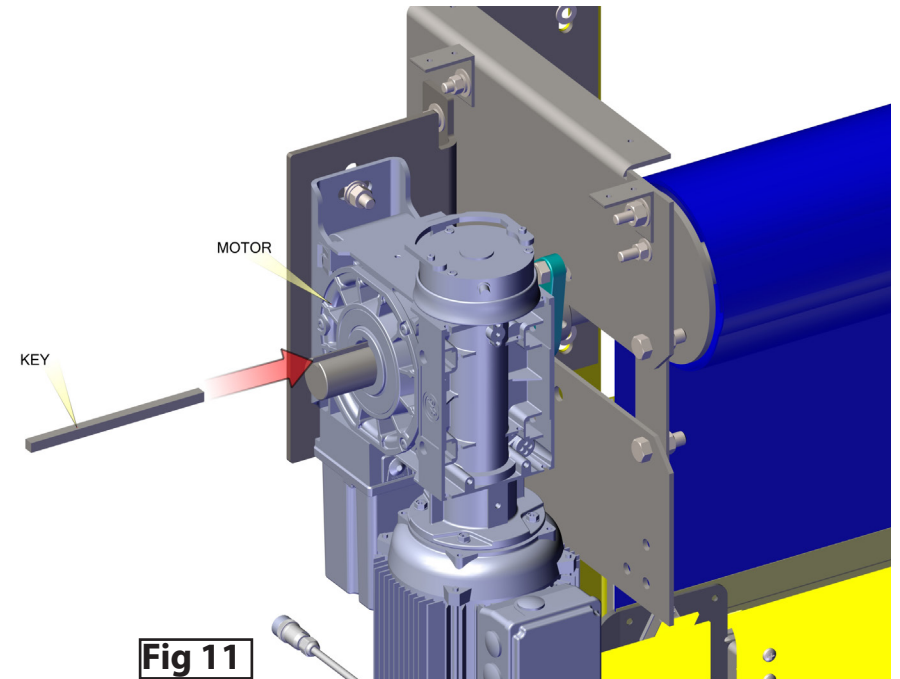
## SECTION 3 - DOOR INSTALLATION (continued....)

### STEP 4 INSTALL MOTOR

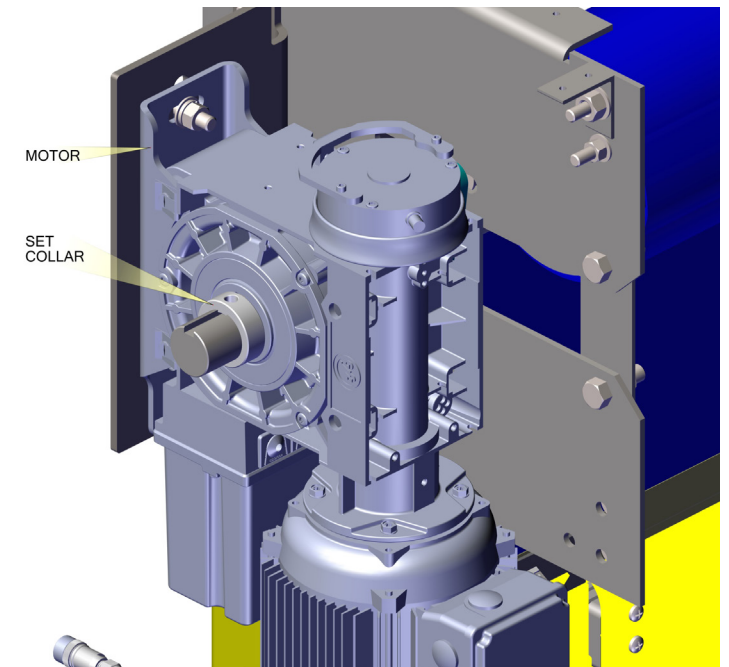
- Remove pre-installed nuts and washers from headplates, as shown in FIG 10. ONLY remove the nuts and washers from the two bolts, as shown in FIG 10.
- Slide motor onto shaft, as shown in FIG 10.
- Re-install the nuts and washers onto the bolts in the headplate, securing the motor.
- Rotate the curtain assembly shaft to align it with the keyway on the motor.
- Insert the key into the keyway, as shown in FIG 11.
- Slide the set collar onto the shaft up against the motor. Tighten set screw in the set collar, as shown in FIG 11A.



**Fig 10**



**Fig 11**



**Fig 11A**

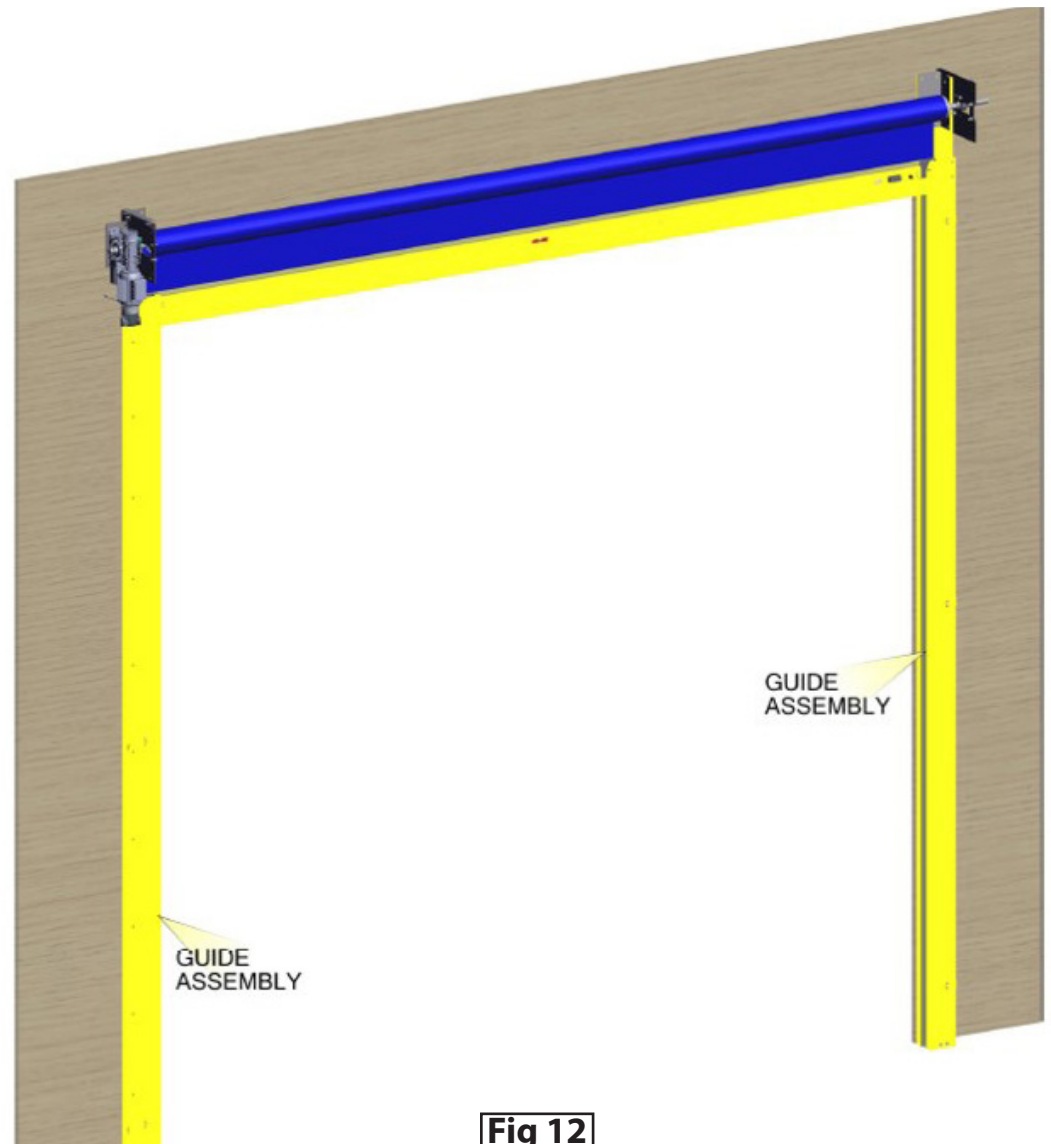
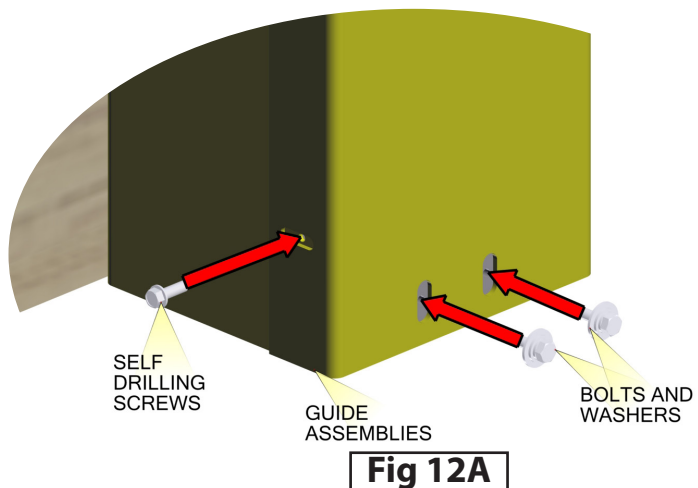
## SECTION 3 - DOOR INSTALLATION (continued....)

### STEP 5 TIGHTEN CURTAIN ASSEMBLY BOLTS

- Check that the curtain assembly is level and square with the jamb.
- Tighten the nuts, bolts, and set screws of the bearings from step 3.
- Tighten the nuts and bolts of the motor bracket from step 4.
- Be sure the set screws of the sprocket and set collars are tight from step 4.
- Remove factory banding around curtain.

### STEP 6 CLOSE GUIDE ASSEMBLIES

- Close the hinged guide assemblies and bolt in place using the self drilling screws provided, as shown in FIG 12.
- Using the bolts and washers provided attach the front guide to the floor bracket at each slotted hole locations, as shown in FIG 12A.



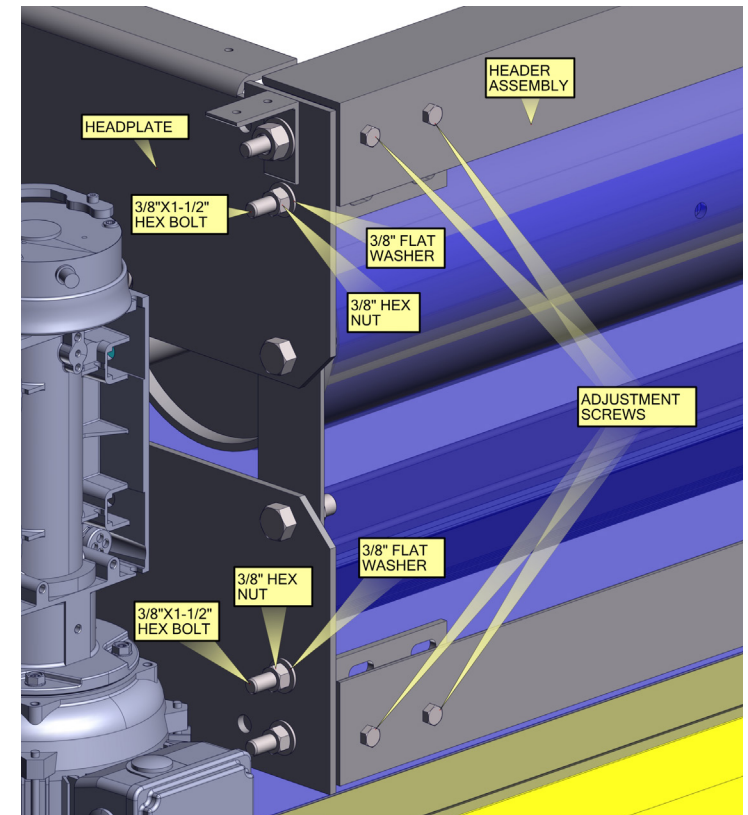
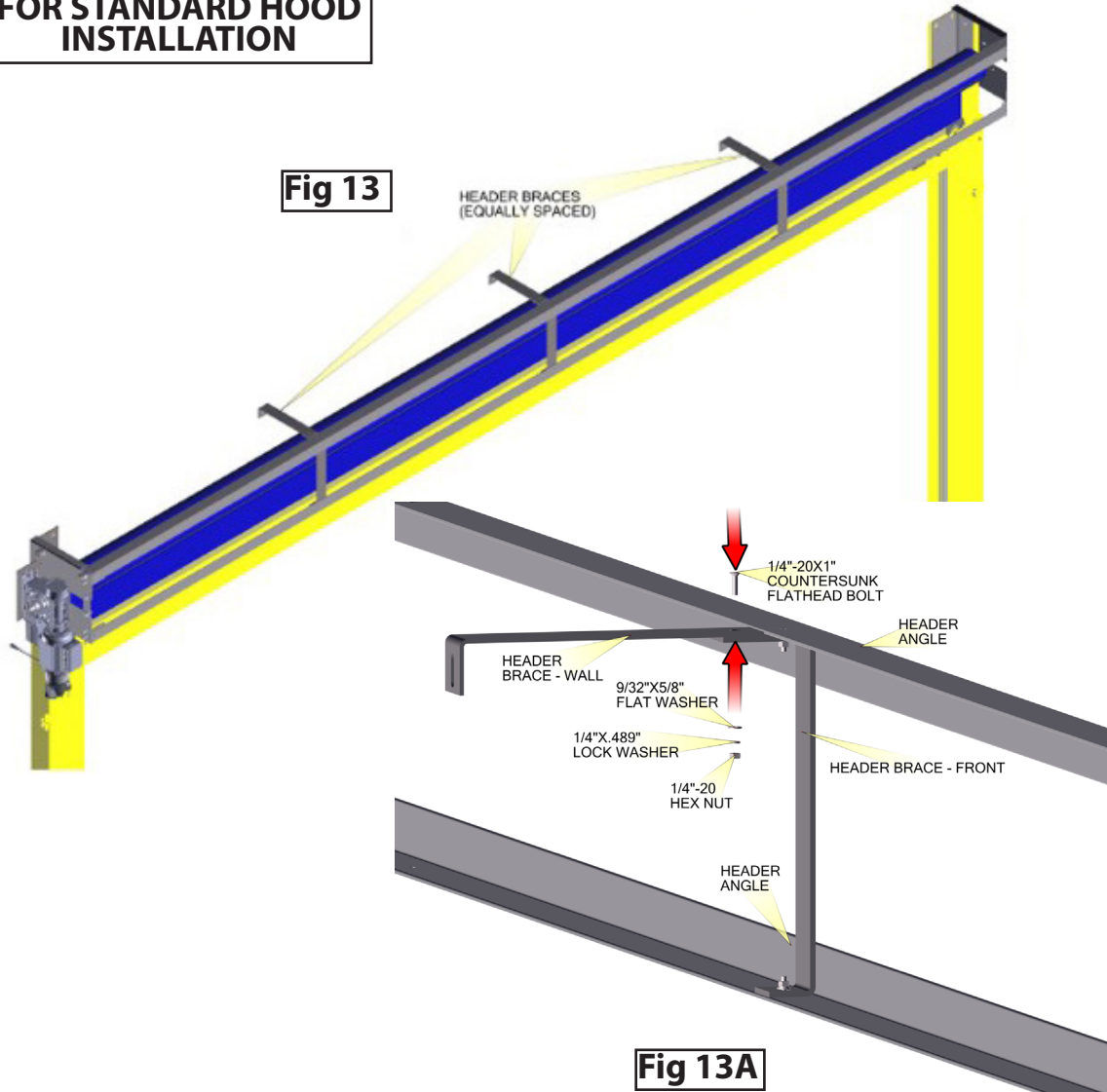
# SECTION 3 - DOOR INSTALLATION (continued....)

## STEP 7 INSTALL HEADER ASSEMBLY WITH STANDARD HOOD

**NOTE:** If you have a sloped hood, skip this step and proceed with Step 7A.

- Locate nuts and washers in the hardware bag to be used for header assembly and attachment.
- Assemble the braces to the header angles, as shown in FIG 13 and FIG 13A.
- Align the header assemblies, as shown in FIG 13B and install using the attachment hardware from the hardware bag.
- You may need to use the adjustment screws to fit the header assemblies between the headplates.
- Tighten all hardware used in this step when proper fit is achieved.

### FOR STANDARD HOOD INSTALLATION



**Fig 13B**

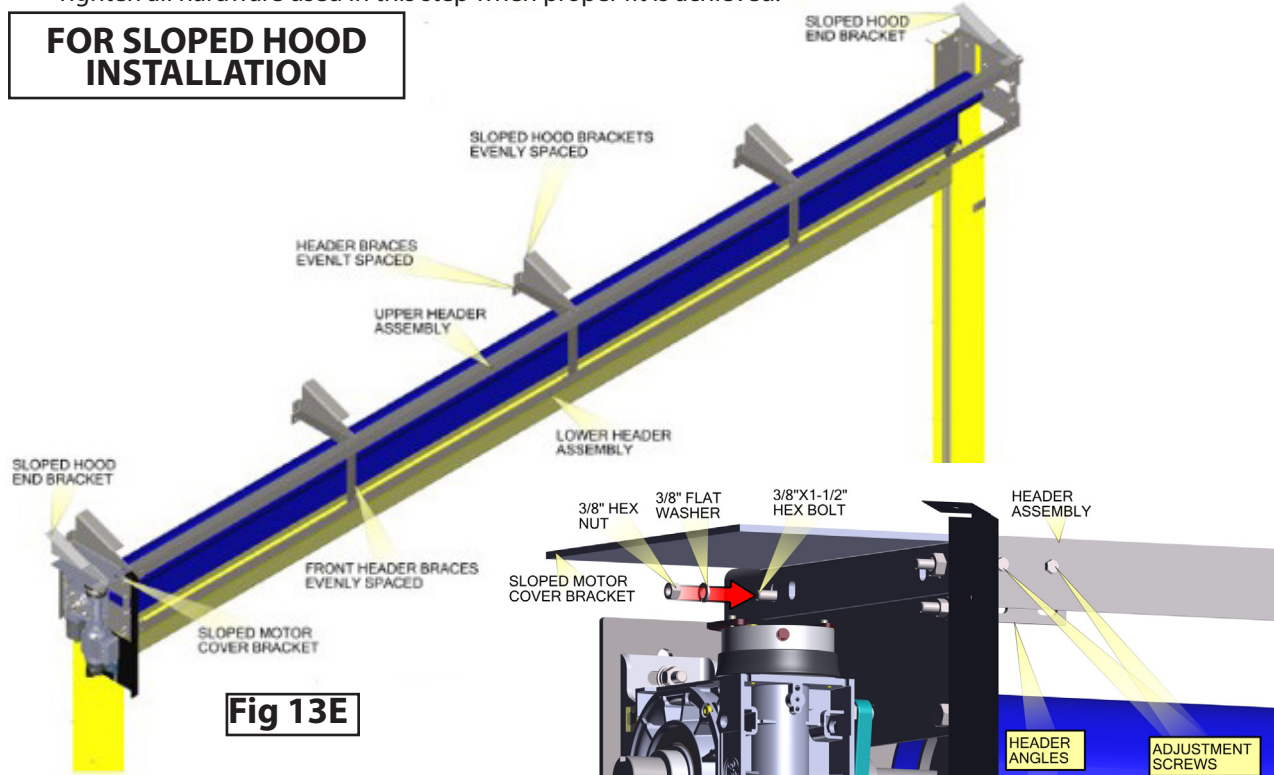
# SECTION 3 - DOOR INSTALLATION (continued....)

## STEP 7A INSTALL HEADER ASSEMBLY WITH SLOPED HOOD

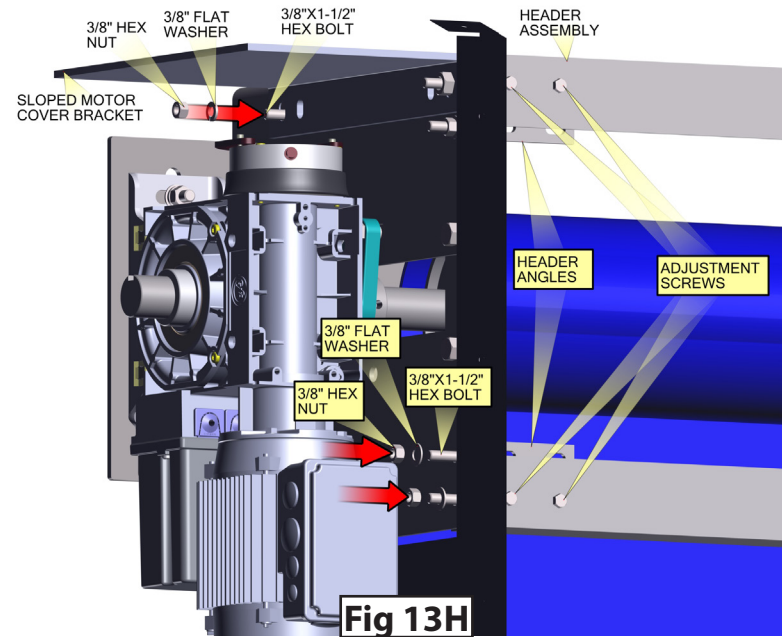
**NOTE:** If you have a sloped hood, proceed with this Step 7A.

- Locate nuts and washers in the hardware bag to be used for header assembly and attachment.
- Assemble the components of the header assembly, as shown in FIG 13E, FIG 13F and FIG 13G.
- Align the header assemblies, as shown in FIG 13H and install using the attachment hardware from the hardware bag.
- You may need to use the adjustment screws to fit the header assemblies between the headplates.
- Tighten all hardware used in this step when proper fit is achieved.

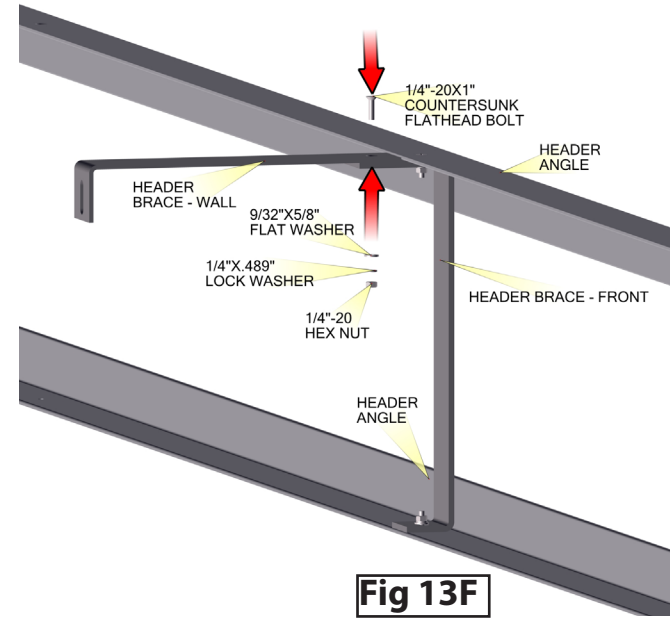
**FOR SLOPED HOOD INSTALLATION**



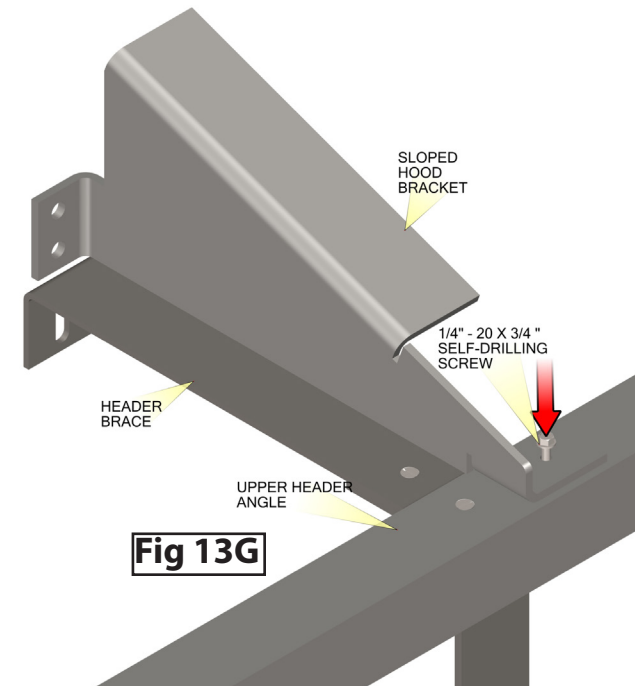
**Fig 13E**



**Fig 13H**



**Fig 13F**



**Fig 13G**

## SECTION 3 - DOOR INSTALLATION (continued....)

### STEP 8 | INSTALL JUNCTION BOX

Find a suitable and easily accessible location for the Junction Box, Fig. 14.

- Locate the Junction Box on the wall near the motor, but OUTSIDE the motor cover. Verify component cables will reach before mounting the Junction Box.
- Away from heat sources.
- With no interference of moving parts of the door system.
- Where cables can be well secured while preventing unnecessary strain.
- Use the Junction Box exterior mounting fixtures to mount to the wall using appropriate fasteners (Fasteners not provided)

### STEP 9 | INSTALL CONTROLLER

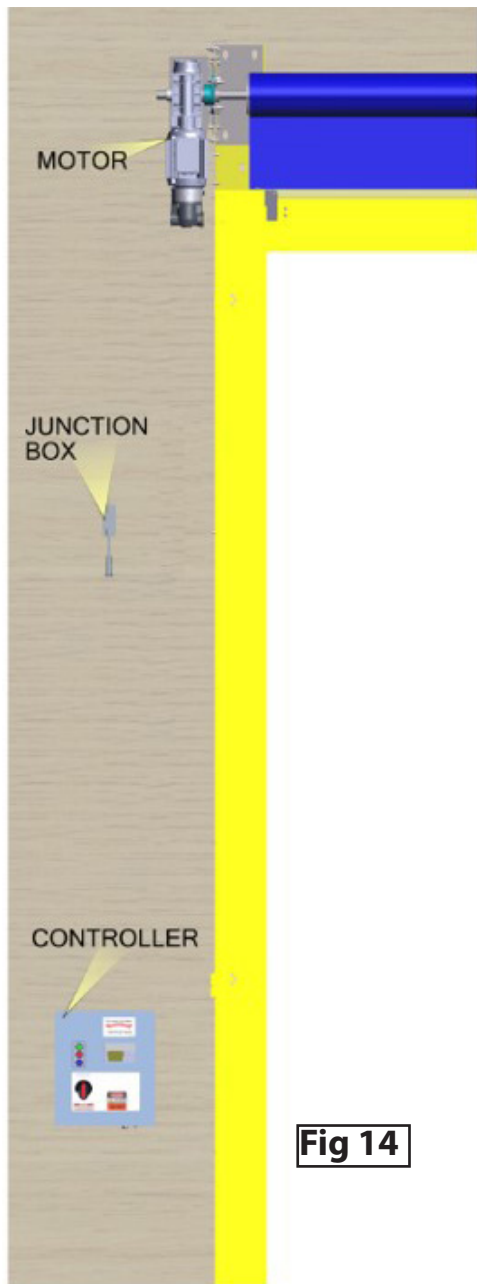
Find a suitable and easily accessible location for the Controller, Fig. 14.

(Your controller may look different than the one pictured.)

- Adjacent to the door, on the wall, about 5 feet above the floor at the center of the panel (roughly eye level). It may be mounted higher in commercial applications to reduce tampering.
- Where all moving parts of the door system are visible while at the control panel.
- Away from heat sources.
- With no interference of moving parts of the door system.
- Where cables can be well secured while preventing unnecessary strain.
- Mount the Control Panel to the wall using appropriate fasteners. (Fasteners not provided) Use supplied mounting tabs as necessary.

### STEP 10 | MOTOR AND CONTROLLER WIRING

- For instructions on wiring the three phase controller see section 4 pages 20-25.



**Fig 14**



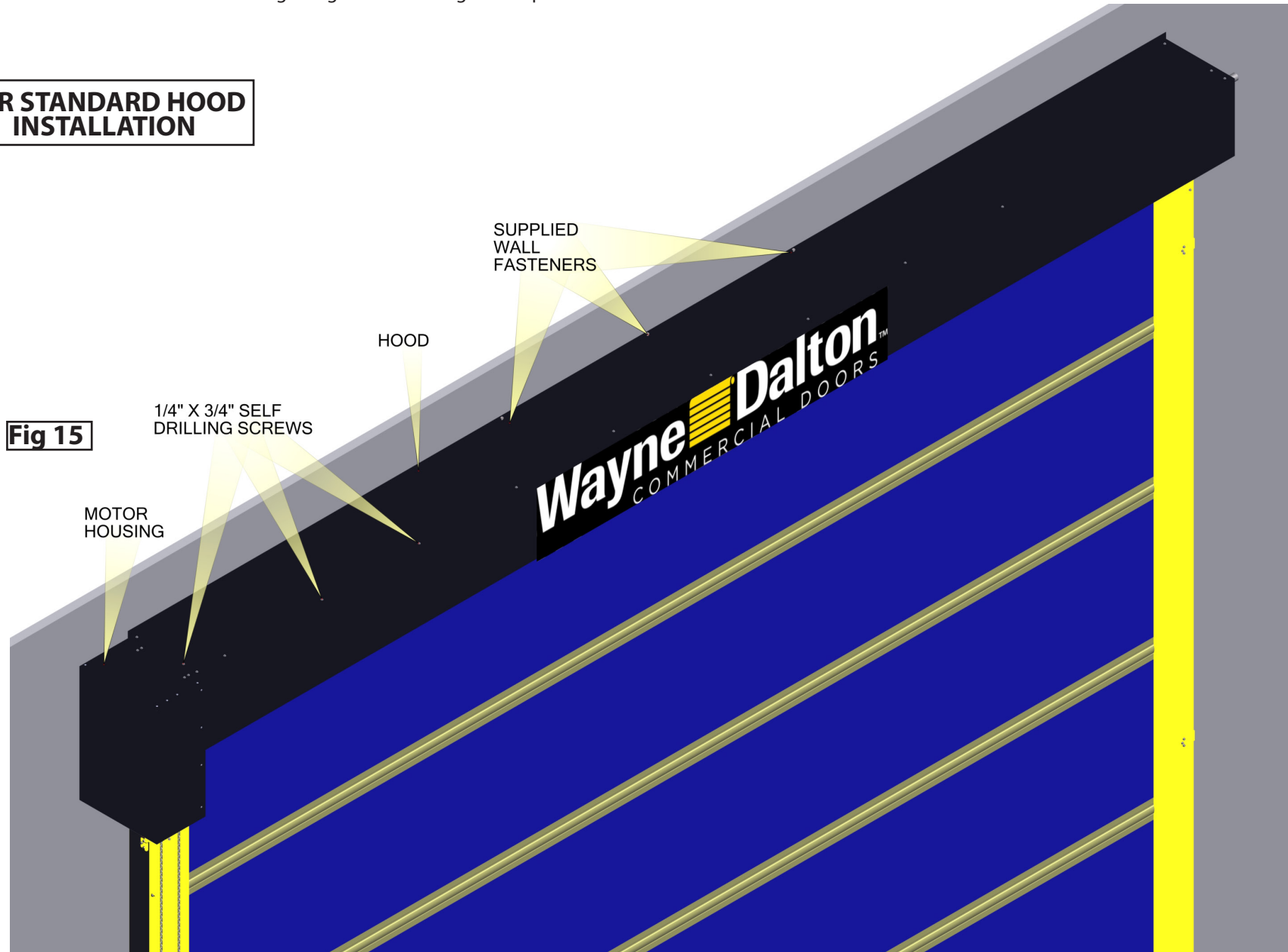
# SECTION 3 - DOOR INSTALLATION (continued....)

## STEP 11 INSTALL STANDARD HOOD AND STANDARD MOTOR HOUSING

**NOTE:** If you have a sloped hood, skip this step and proceed with Step 11A.

- Install the hood and motor housing using the self drilling screws provided.

**FOR STANDARD HOOD  
INSTALLATION**



**Fig 15**

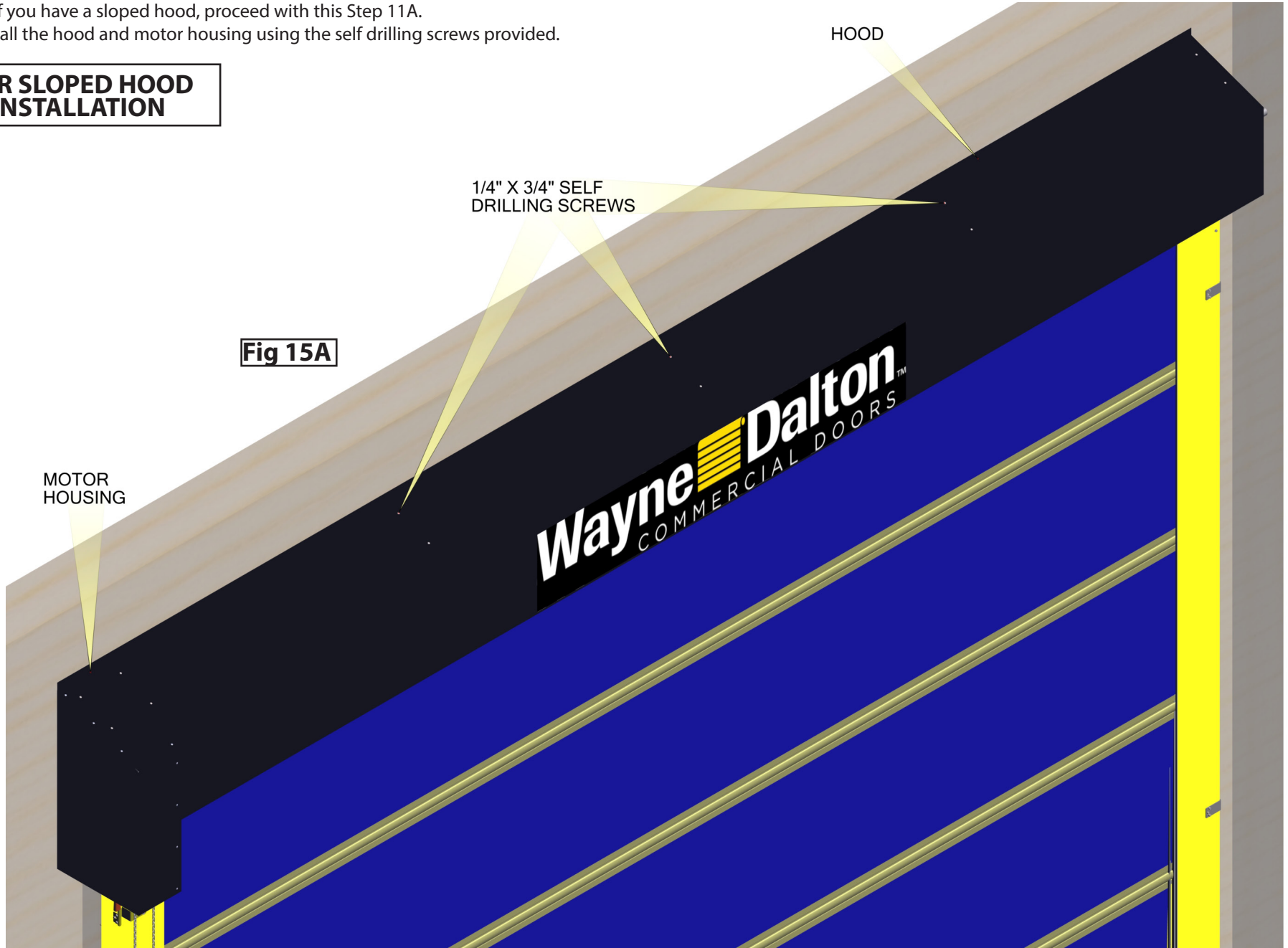
# SECTION 3 - DOOR INSTALLATION (continued....)

## STEP 11A INSTALL SLOPED HOOD AND SLOPED MOTOR HOUSING

**NOTE:** If you have a sloped hood, proceed with this Step 11A.

- Install the hood and motor housing using the self drilling screws provided.

**FOR SLOPED HOOD  
INSTALLATION**



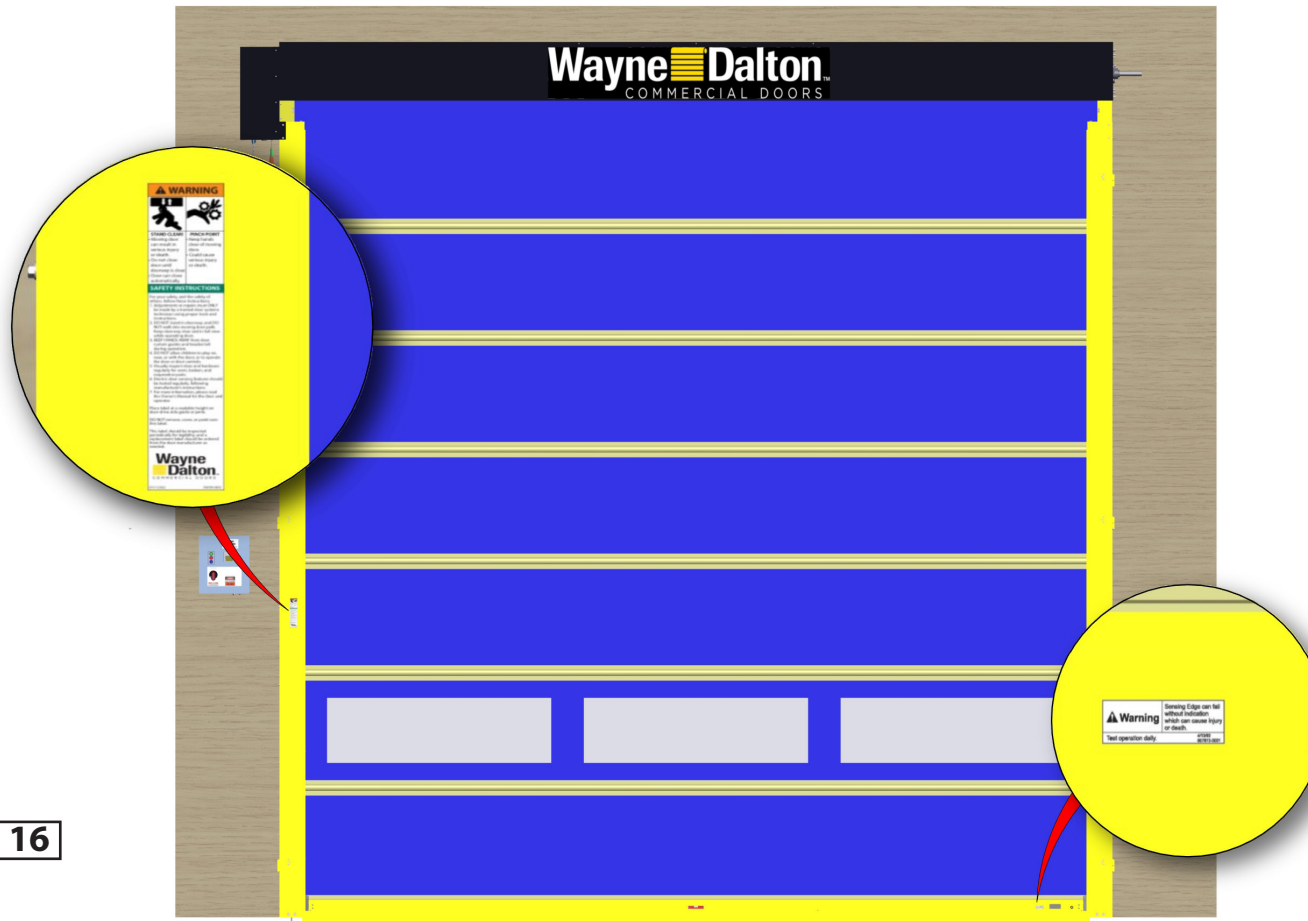
## SECTION 3 - DOOR INSTALLATION (continued....)

### STEP 12 APPLY WARNING LABEL

Product safety label must be installed.

- Place safety label on drive side guide at a readable height.
- Place sensing edge safety label on the bottom bar.

**NOTE:** Product safety labels should be periodically inspected and cleaned by the product user as necessary to maintain good legibility. Order replacement safety labels from the door manufacturer as required to maintain legibility.



**Fig 16**

# SECTION 4 - LOW VOLTAGE WIRING 3 PHASE CONTROLLER

## STEP 1 CONNECT CONTROLLER LOW VOLTAGE WIRING (EXTERNAL)

Connections to the door are completed by attaching the two screw-in cables to the control panel's base, Fig 19 page 22.

-5 pin cable connector (See Fig 21 and 22 on page 24)

- Position Sensor

-12 pin cable connector (See Fig 19 on page 22)

- Photoeye Receiver
- Photoeye Transmitter

**IMPORTANT:** WHEN INSTALLING PHOTOEYE CABLES, ENSURE THEY DO NOT IMPEDE THE OPERATION OF THE DOOR.

IF YOU HAVE A HOOD: INSTALL THE CABLES ON TOP OF THE HOOD TO THE JUNCTION BOX.

IF YOU DON'T HAVE A HOOD: INSTALL THE CABLES ALONG THE LINTEL ANGLE AND AWAY FROM THE CURTAIN.

- Sensing Edge
- Hand Crank Interlock Switch
- Optional Input 1

## STEP 2 INSTALL OPTIONAL DEVICES

### INSTALL MOTION SENSOR (optionally purchased)

Motion Sensor is an optional component purchased separately and does **not** come with door.

- Follow the installation instructions accompanying the Motion Sensor.
- Install wiring per wiring diagram FIG 24 page 25.

### INSTALL LOOP DETECTOR (optionally purchased)

Loop Detector is an optional component purchased separately and does **not** come with door.

- Follow the installation instructions accompanying the Loop Detector.
- Install wiring per wiring diagram FIG 25 page 25.

### INSTALL RADIO CONTROLS (optionally purchased)

Radio Controls are an optional component purchased separately and does **not** come with door.

- Follow the installation instructions accompanying the Radio Controls.
- Install wiring per wiring diagram FIG 23 page 25.

### INSTALL WALL MOUNTED PUSH BUTTON (optionally purchased)

Wall Mounted Push Buttons are an optional component purchased separately and does **not** come with door.

- Install wiring per wiring diagram FIG 8-J page 42.

## STEP 3 CONNECT OPTIONAL DEVICES

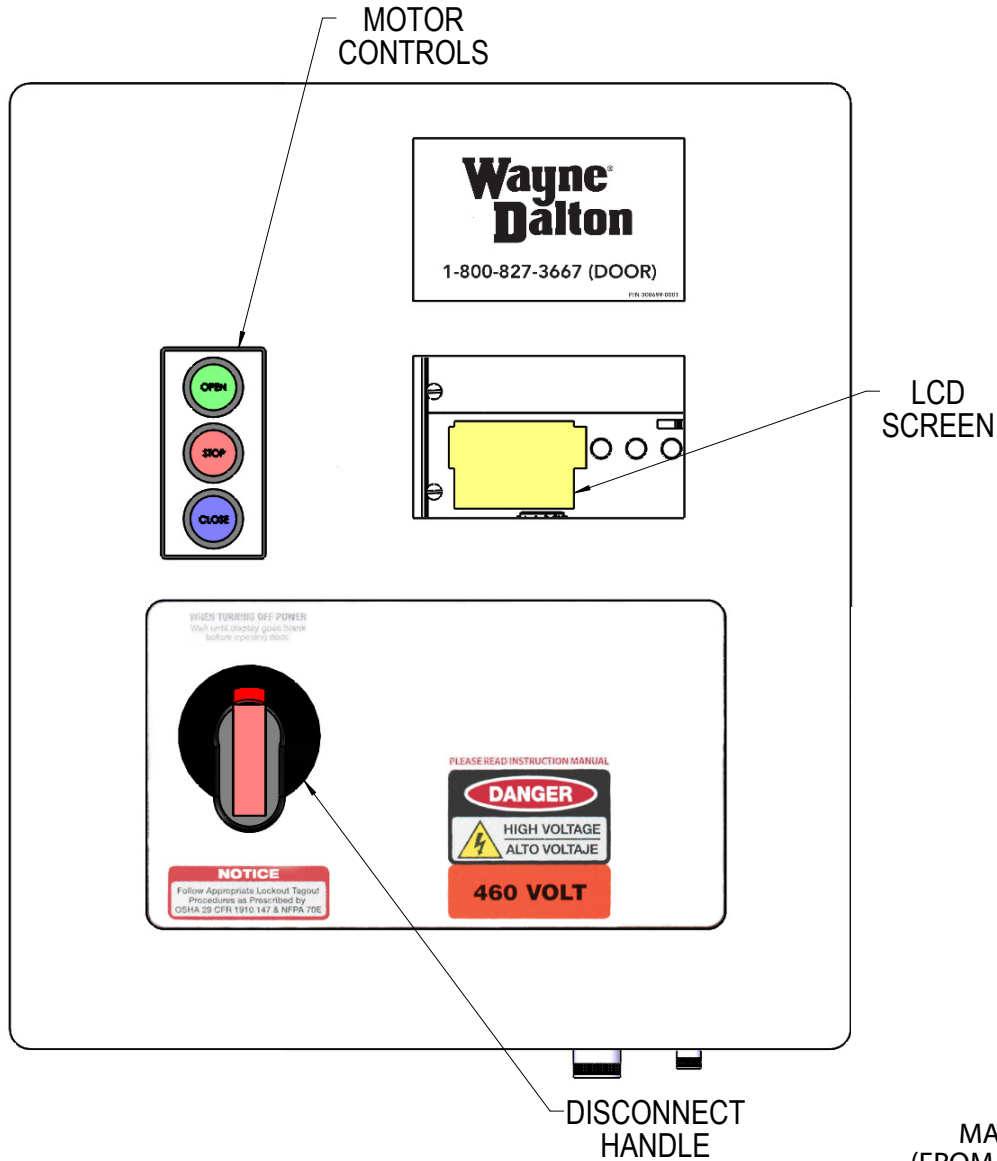
One option may be connected to the Junction Box by the installer. Additional options must be wired to the spare inputs on the Control panel. Use the corresponding option inputs.

- Radio Remote to the Junction Box connector 5 labeled "Option 1".
- Floor loop to the Junction Box connector 5 labeled "Option 1".
- Motion Detector to the Junction Box connector 5 labeled "Option 1".
- Wall mounted push button stations to the main Control Panel Fig. 8-J on page 42.

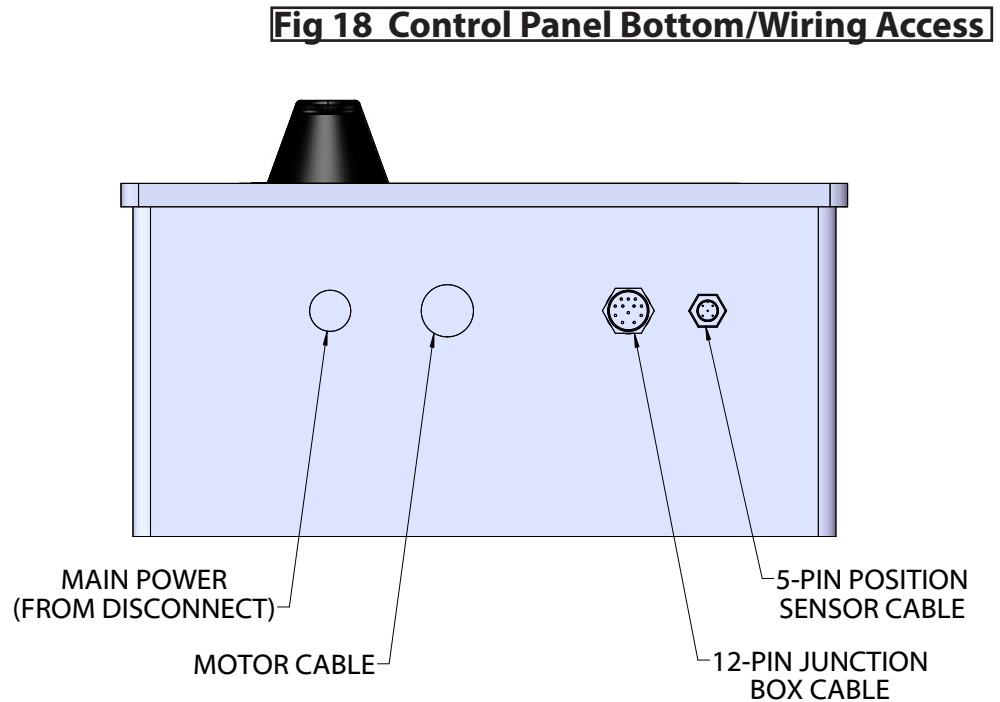
**Note:** When installing push buttons, use the 24V supplied by the Control Unit as the common.

# SECTION 4 - LOW VOLTAGE WIRING 3 PHASE (continued....)

## 1. MAIN COMPONENT OVERVIEW, FIG 17 AND 18

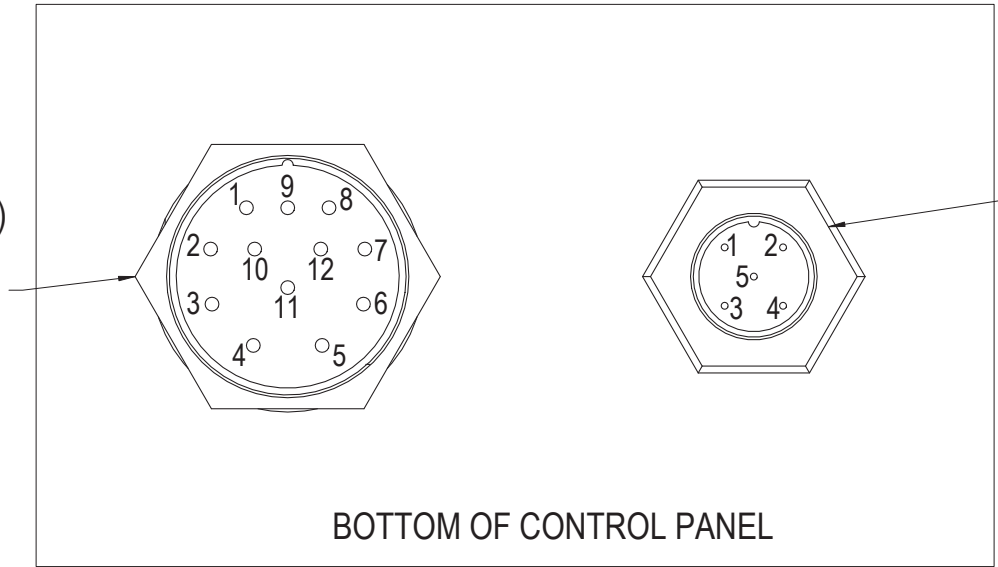


**Fig 17 Control Panel Front Cover**

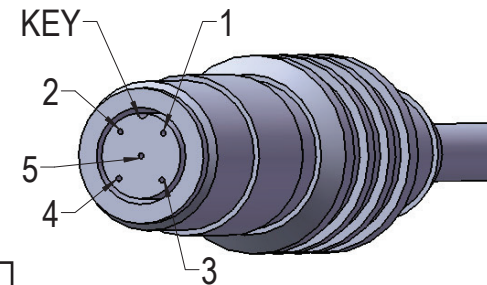
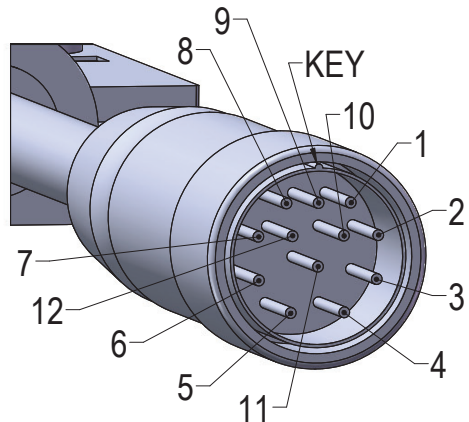


# SECTION 4 - LOW VOLTAGE WIRING 3 PHASE (continued....)

- TO JUNCTION BOX
1. SENSING EDGE (WHITE)
  2. INTERLOCK (GREEN)
  3. NOT USED
  4. PHOTOEYE RECEIVER (GRAY)
  5. OPTION 1 (PINK)
  6. OPTION 2 (RED)
  7. NOT USED
  8. NOT USED
  9. NOT USED
  10. COMMON (0V) (BLUE)
  11. POWER (24V) (BROWN)
  12. GND (GREEN/YELLOW)

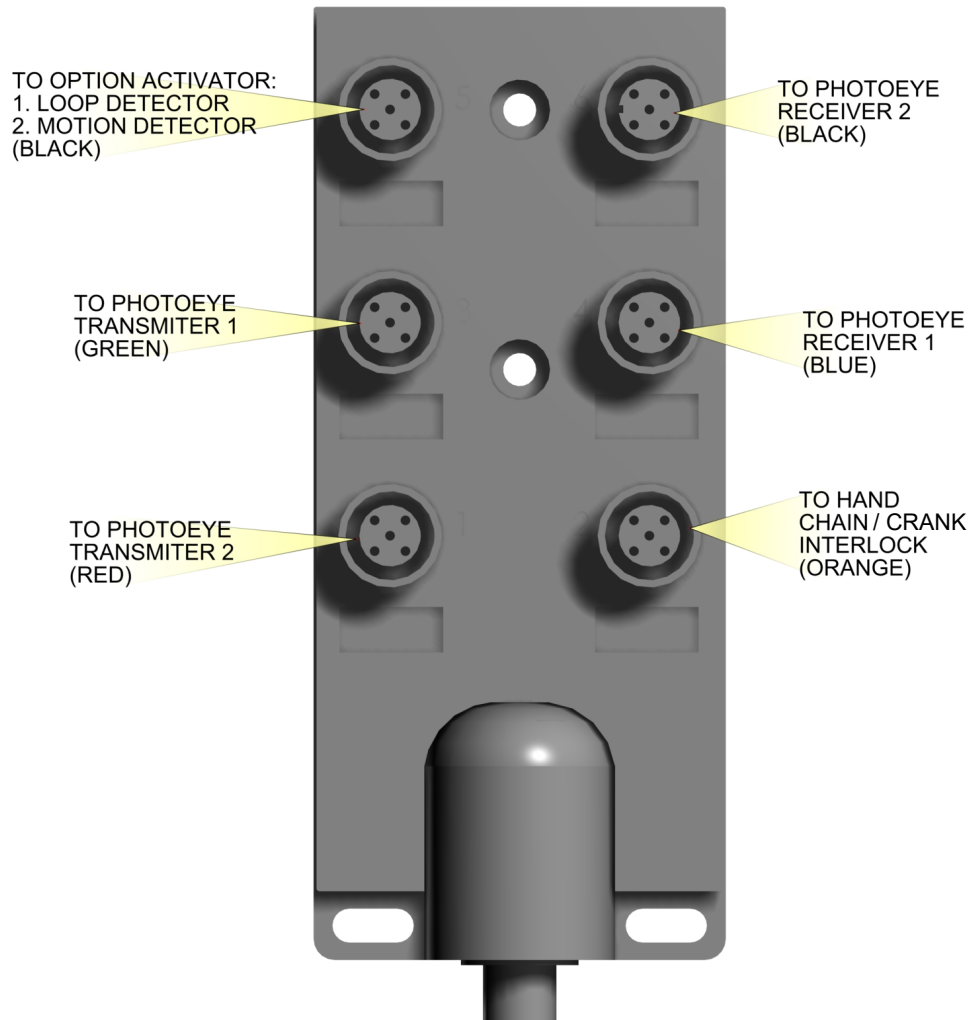


- TO POSITION SENSOR
1. 12V (BROWN)
  2. A SIGNAL (WHITE)
  3. B SIGNAL (BLUE)
  4. 0V (BLACK)
  5. PULSE (GRAY)



**Fig 19 Cables to Control Panel**

# SECTION 4 - LOW VOLTAGE WIRING 3 PHASE (continued....)



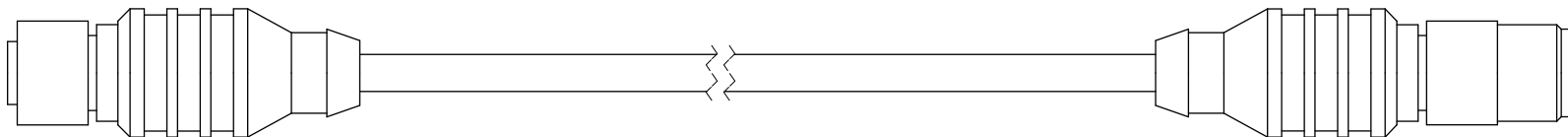
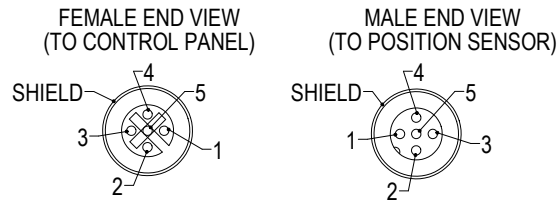
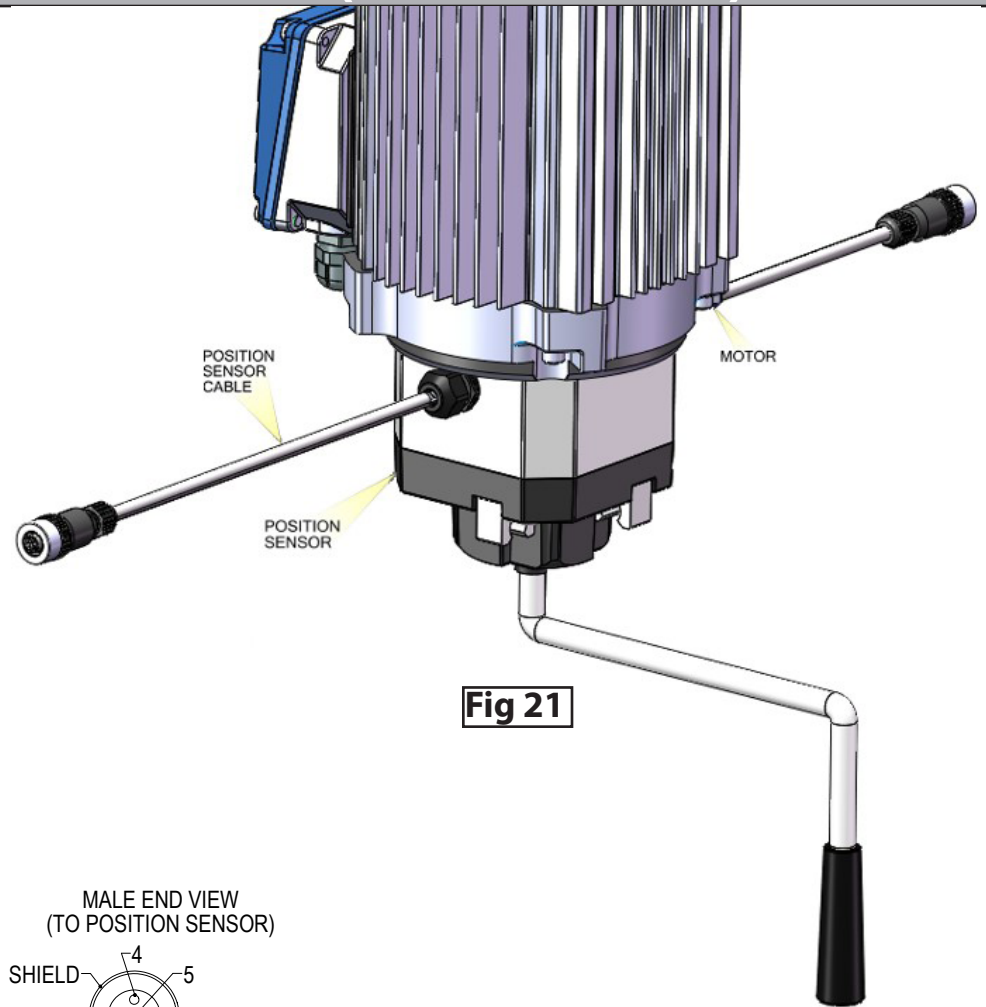
**Fig 20 JUNCTION BOX WIRING**  
**Connections for most factory wired external control functions.**

# SECTION 4 - LOW VOLTAGE WIRING 3 PHASE (continued....)

## 4. POSITION SENSOR WIRING CONNECTIONS AND SETTINGS

The Position Sensor comes pre installed to the motor. See Fig 21 for location.

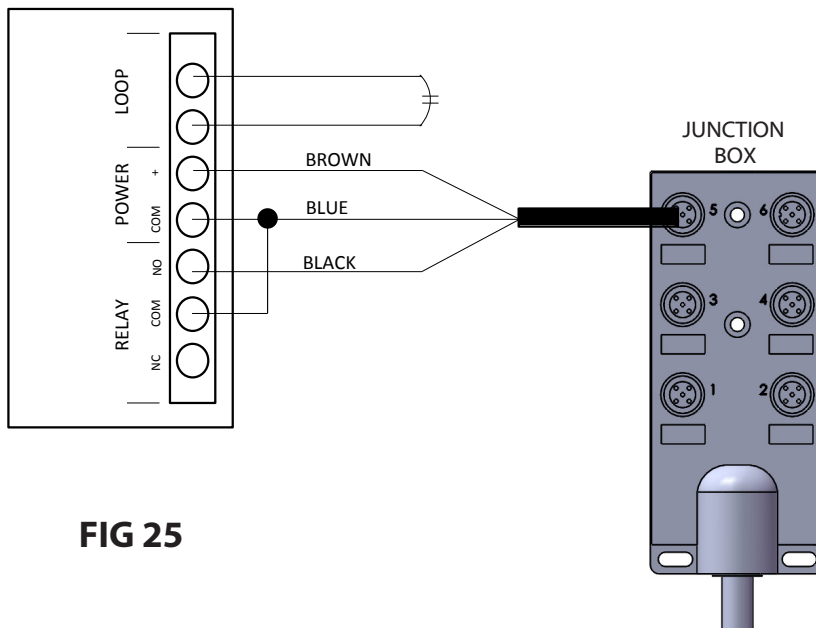
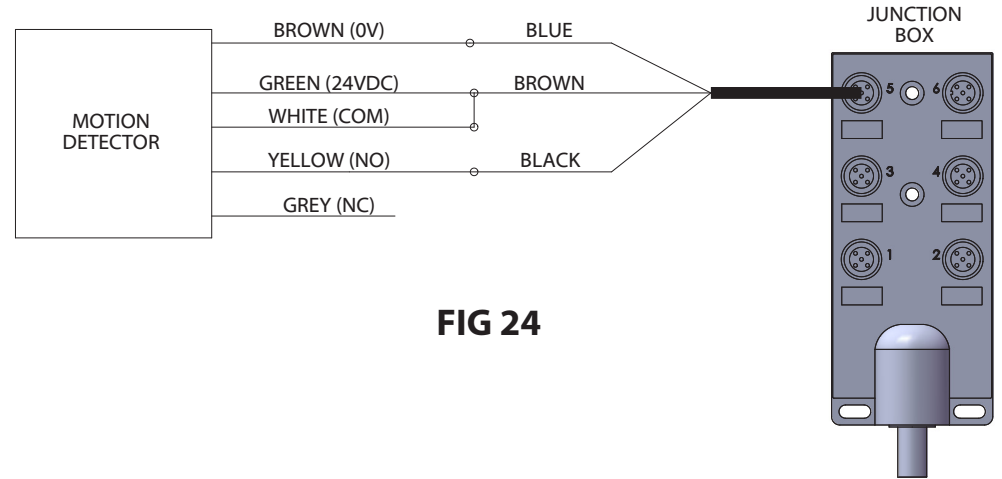
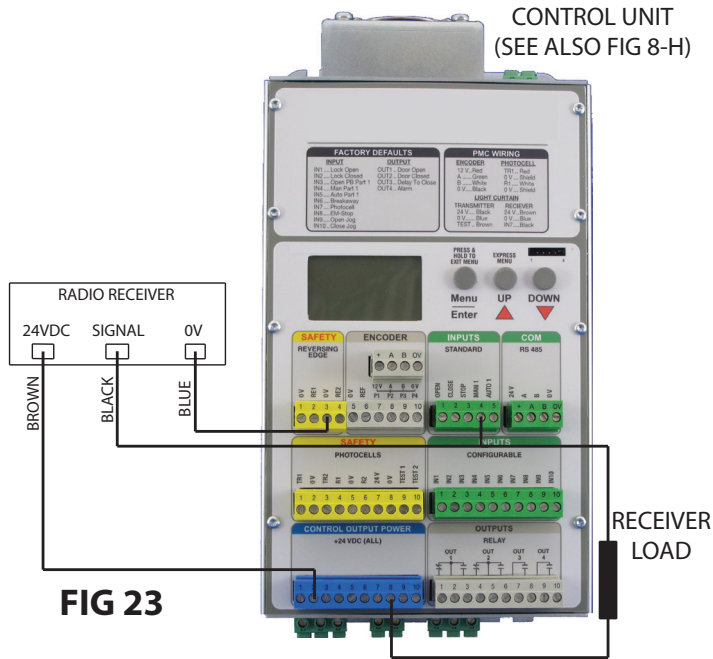
- Attach one end of the M12 position sensor cable to the Position Sensor.
- Attach the other end of the M12 position sensor cable to the Control Panel.



**Fig 22 POSITION SENSOR CABLE**



# SECTION 4 - LOW VOLTAGE WIRING 3 PHASE (continued....)



## 5. Options wiring and settings

- Wire the supplied cables from the junction box to the optional equipment as shown in FIG 24, and FIG 25.
- Wire the Radio receiver directly into the controller (through an available opening) as shown in FIG 23.

**CAUTION**

Door will open/close once connected.

- For the radio receiver, wire the supplied receiver load into the control unit from MAN1 to 24VDC (blue terminal).
  - Access the menu and navigate to system config-> Inputs-> MAN1-> Logic.
  - Select NC parameter and exit the menu.
  - To update the auto close timer, access the express menu->MAN1 Timer
- The motion detector and loop detector can be operational once connected to the junction box. They are wired for the default configuration.
  - To update the auto close timer, access the express menu->AUTO1 Timer.

## SECTION 5 - HIGH VOLTAGE WIRING 3 PHASE CONTROLLER

### WARNING

Before beginning this phase of the installation, ensure power supply is **DISCONNECTED** to avoid serious injury or death!

### CAUTION

ADV-X Door Models must be supplied by a properly grounded voltage supply, e.g. 220/240 VAC 1-phase or 208/230/460/575 VAC 3-phase. Floating (Open Delta) ungrounded voltage supply sources should not be used. For 480 VAC, 240 VAC or 120 VAC unbalanced systems should **NOT** be used. Voltage unbalance is a common occurrence on delta supply systems, which power both single and 3-phase load. This can lead to unequal voltages on each phase leg. Voltage unbalance can cause deterioration of motor performance such as loss of torque, overheating, decreases in the winding insulation life, and can cause motor starter contacts on the control panel to permanently “weld” closed. Voltage unbalance can be caused by inadequate conductor sizing, transformer sizing, excessive single phase loads, poor grounding or intermittent high resistance faults which may cause destructive over-voltages to occur. Any single phase loads should be evenly distributed as much as possible between the 3 phases. Consult a licensed electrician if you have any questions.

***Overhead Door Corporation's warranty will not cover damage caused by failure of the motor, control panel or other electrical components due to the use of an inadequately grounded system.***

ADV-X models 880 and 881 are available in single phase and 3-phase voltages. Single phase voltages are available in 110-120VAC and 220-240VAC. 3 phase voltages are available in 240VAC, 480VAC, and 575VAC. ADV-X model 882, 883, 884, and 885 are available in 3 phase voltages only. **YOUR LOCAL CODES MAY REQUIRE THAT THE INCOMING POWER TO YOUR DOOR HAVE A LOCK-OUT / TAG-OUT EQUIPPED FUSED DISCONNECT SWITCH (TO BE FURNISHED BY OTHERS) WITHIN EYESIGHT OF THE DOOR'S CONTROL PANEL.** Incoming power wiring must meet all NEC and local building codes, plus be properly sized for the control panel's amperage rating on the nameplate. To reduce the risk of electric shock, the chassis of the control panel must be properly grounded.

### WARNING

To avoid serious injury or death:

- It is recommended that line voltage wiring be performed by a qualified electrician.
- Be sure that electrical power has been disconnected from the input wires being connected to the operator prior to handling these wires. An appropriate lock-out/tag-out procedure is recommended.
- Line voltage must meet all local building codes.
- Make sure operator voltage, phase, and frequency ratings are identical to the job site line voltage ratings.
- Input power wiring must be properly sized for the operators amperage rating.

### WARNING

To avoid serious injury or death DO NOT calibrate motor or operate door unless doorway is in sight and free of obstructions. Keep clear of opening while door is moving.

## SECTION 5 - HIGH VOLTAGE WIRING 3 PHASE (continued....)

### **⚠ DANGER**

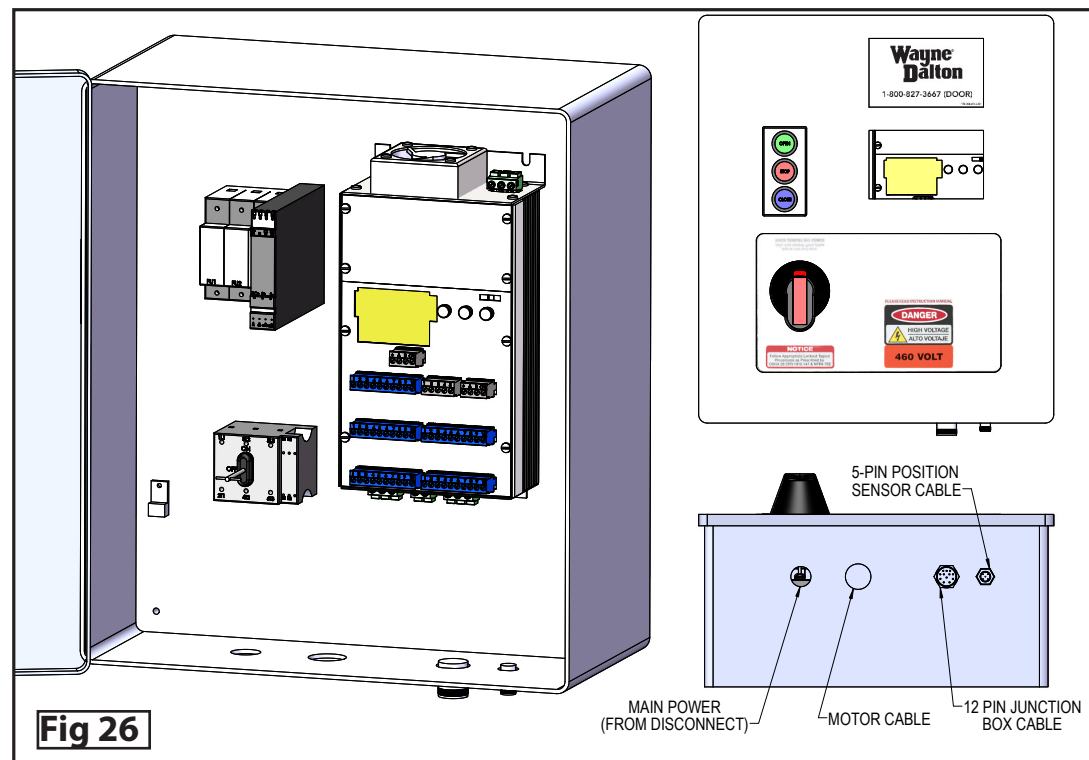
Before beginning this phase of installation, ensure **POWER SUPPLY is disconnected** to avoid serious injury or death!

**MOTOR & POWER WIRING (HIGH VOLTAGE)** (These tasks are also diagrammed in Fig 26, 27, and 28 on pages 27-29.)

- A.** Route **Motor Power Cable** (provided, factory wired to motor) through water-tight fitting in the **SECOND** hole from left side of Control Panel bottom.
1. Connect the lighter gauge, twisted pair wires to the blue colored **Motor Brake** terminals next to the disconnect switch. Either wire can connect to either terminal. It is labeled "B1" and "B2".
  2. Connect the green and yellow ground wire, the braided cable shield and the non-insulated ground wire together to the Green and Yellow terminal.
  3. Connect the thicker motor wires to Terminals T1, T2 and T3 on the green screw connectors on the bottom left of the control unit. The order doesn't matter since the motor rotation can be changed using the internal programming during Set-up in **Section 6**.

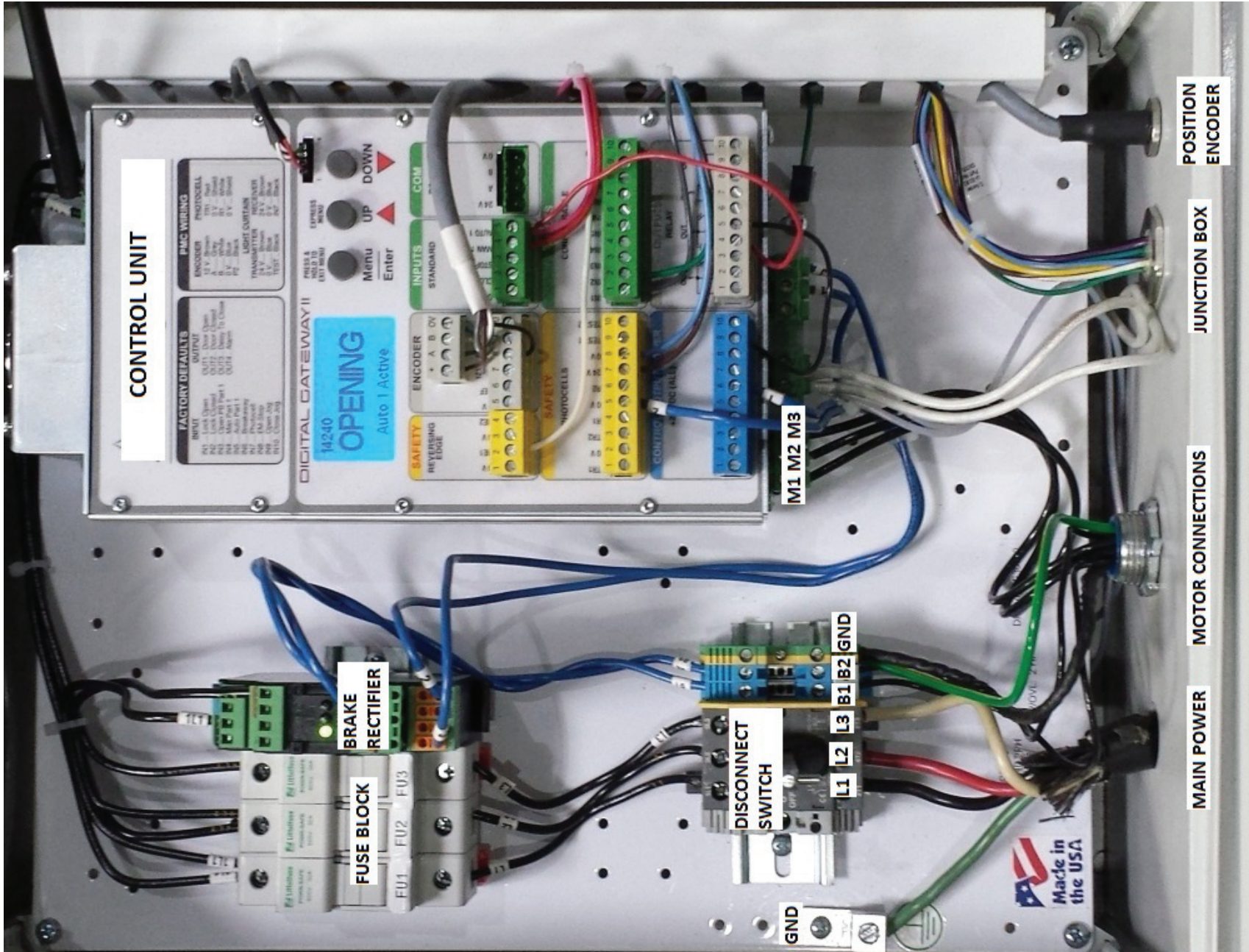
**A licensed electrician must perform the following step.**

- B.** Route **Main Power Cable** (not provided) through a water-tight fitting (not provided) in the **FIRST** hole from the left side of the Control Panel bottom.
- Connect 3-phase power lines to the disconnect. Connect the ground wire to the Ground Terminal to the left of the disconnect.

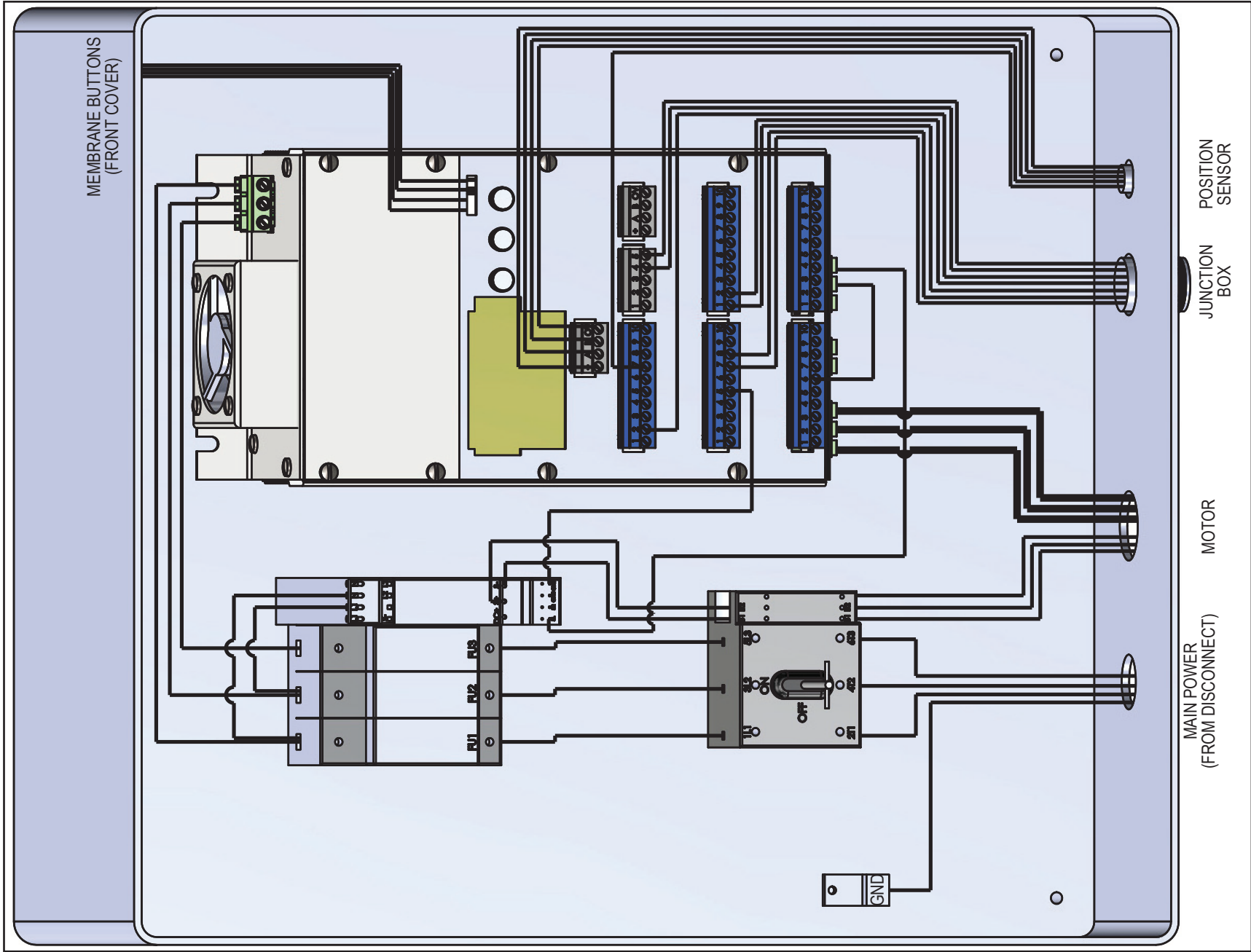


# SECTION 5 - HIGH VOLTAGE WIRING 3 PHASE (continued....)

Fig 27 Control Panel Contents (See also FIG 8-H) pg 40



# SECTION 5 - HIGH VOLTAGE WIRING 3 PHASE (continued....)



**Fig 28 Control Panel Wiring Diagram (480V)**

# SECTION 6 - INITIAL STARTUP PROCEDURE 3 PHASE

## STEP 1 APPLY POWER (LINE VOLTAGE)

Turn the disconnect handle Clockwise to the ON position in order to apply power to the Control Panel. A blue splash screen will pop up displaying the default profile, and controller data (consists of serial number, output capacity, software version, etc). Verify the system motor rating, and power ratings correspond with each other.

NOTE\* The system information can also be accessed in the SYSTEM STATUS > OVERVIEW menu. (see page 33-34)

## STEP 2 INITIAL LIMIT SETUP

The first time the controller is powered on, you must first set the limits. The LED screen will flash with the error E17, and you must reset the limits. This will also occur whenever the position sensor is disconnected from the controller. The position sensor, photoeyes, sensing edge, and interlock switch must be connected before the limits can be set. If, for any reason, the limits cannot be set, please refer to troubleshooting section 8.

A. To enter the Menu, press and hold the OPEN, STOP, CLOSE membrane buttons for 3 seconds. A count down timer on the top left corner of the LED screen will display the remaining time left to hold. Refer to **Fig 7-A** pg 32 for the complete menu structure.

B. Holding the Stop button for 1 second will go back up a level in the Menu. Continuing to hold the STOP button will continue to go back up the menu structure until the main screen.

C. Once in the main screen, a 25 second countdown timer will show on the upper left hand corner. This countdown timer displays how long until the OPEN/STOP/CLOSE buttons will no longer give access to the MENU. Once inside the menu, use the **OPEN button to scroll up, STOP button to enter**, and **CLOSE to scroll down**. Pressing OPEN/STOP/CLOSE immediately exits the counter.

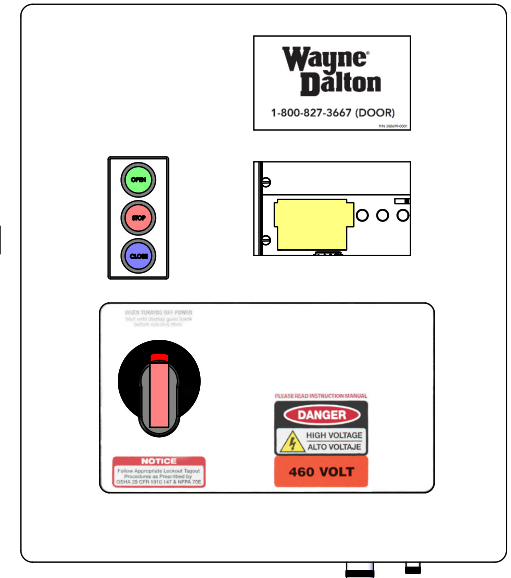
Note: Instead of using the front panel buttons one can access the menu from the control unit using menu/enter, the ▲, and ▼ buttons.

1. Enter the Menus
2. Scroll down until you reach the LIMIT SETUP and hit enter.
3. Scroll down and enter into Quick Setup. A code request screen will appear. Enter the 3 digit pass code to gain access by scrolling up or down. Your pass code is located on a separate addendum.

NOTE: **Do not** display or freely give out the pass code.

4. Follow the prompts in order to set the open and close limits on the door. During this time, use the OPEN, CLOSE buttons to move the door. Again, the STOP button will be used as the ENTER function. If no error has occurred, it will then display QUICK SETUP DONE, otherwise if failed; QUICK SETUP ABORTED and it must be redone. Refer to Trouble shooting section 8 if required.

NOTE: When setting the position, the position sensor count will be displayed. Verify the encoder count increases when the door is moving in the up direction, and does not roll over to the negative position.



## SECTION 6 - INITIAL STARTUP PROCEDURE 3 PHASE (continued....)

### ▲ WARNING

All Entrapment Protection Devices are **OFF** in Emergency Jog and the Limits are **NOT SET**. Devices **OFF** while in Emergency Jog include: Edge Contact, Photoeye, Wall push buttons, Radio Control, Limit Sensors, Loop Detector, or any motion sensor used as either an actuator or an Entrapment Protection Device. Only the Interlock remains active. Emergency Jog is the manual control for momentary operation of door via ARROW buttons on the membrane keypad or on the control unit. **USE CAUTION WHILE SETTING UP THE DOOR IN THIS MODE, AND KEEP OPENINGS CLEAR OF PERSONS AND PROPERTY TO AVOID SERIOUS INJURY OR DEATH! Do NOT use Emergency Jog for general door operation.**

#### STEP 3 PAIR THE WIRELESS SENSING EDGE HOST (SEYWAVE HOST)

The wireless sensing edge host must be paired with the controller.

- A. Enter the Menu
- B. Scroll down until you reach the SYSTEM CONFIG and hit enter.
- C. Scroll down and enter into OPTIONS. A code request screen will appear. Enter the 3 digit passcode to gain access by scrolling up or down. Your pass code is located on a separate addendum.
- D. Select SeyWave Host
- E. Select enable and make sure the black box is positioned on enable. If not, select enable and press menu/enter once. The black box will move to enable. Press and hold the menu/enter for a second to back out 1 screen.
- F. Select clear all and press up to confirm.
- G. Select pair and press the sensing edge. The controller will make a beeping noise when the pairing is complete.
- H. Press and hold the menu/enter to go back to the home screen.

#### STEP 4 VERIFICATION

Test each sensor to make sure the controller recognizes the fault.

- A. Photoeyes -Obstruct the beam with a solid object. Photoeye should reverse door direction.
- B. Sensing Edge -Place a solid object, taller than 12", on the floor and close the door. Sensing edge should reverse door direction on contact with object.
- C. Interlock Switch -This is a constant activation sensor, release the hand chain from the switch or remove the crank handle, the door should stop and a fault display.

NOTE: all faults and sensor activations are logged into the Fault Log. Access this through the menu SYSTEM STATUS > FAULT LOG in the Controller Menu. To clear faults hold the STOP button for 1 second once the fault has been fixed.

#### STEP 5 SET SENSING EDGE SENSITIVITY

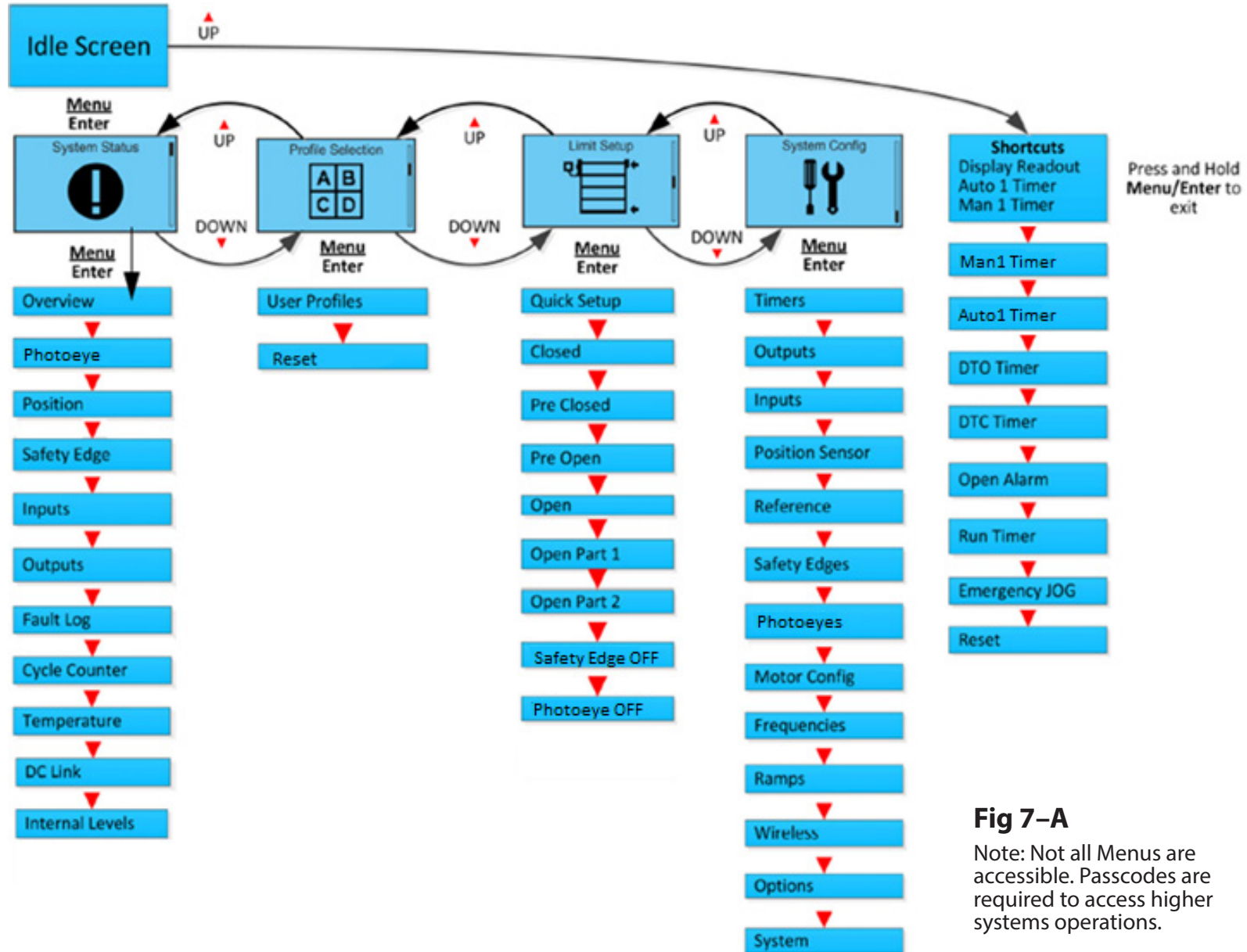
If you are in a high wind area you may need to adjust the sensitivity of the safety edge so that it does not trigger due to a high wind event.

- A. Enter the Menu
- B. Scroll down until you reach the SYSTEM CONFIG and hit enter.
- C. Scroll down and enter Options. Then select Seawave host pairing. Then select impact adjust and preset.
- D. Now make your sensitivity selection low, medium, or high.

# SECTION 7 - MENUS 3 PHASE CONTROLLER

## PART 1 EXPRESS MENU

The Express Menu is accessed by scrolling up, when at the idle screen or after exiting the menus. The express menu contains display options, timers, settings reset, and the emergency JOG. The timer functions in the Express Menu are shortcuts to timers in the system configuration menu without the need of a pass code.



**Fig 7-A**

Note: Not all Menus are accessible. Passcodes are required to access higher systems operations.



# SECTION 7 - MENUS 3 PHASE CONTROLLER (continued....)

## PART 2. SYSTEM STATUS MENU

The System Status menu is read-only and provides parameter status displays for use in setup and troubleshooting. The options of the System Status menu are shown and described below. The controller is fully operational within this menu, allowing real-time parameter updates. To use the System Status menu:

- A. Enter the System Status menu
- B. Scroll down and highlight a menu option.
- C. Enter to view the highlighted option.
- D. Press and hold STOP or ENTER when finished to return to the System Status menu.
- E. Repeat to view other parameters if desired.

Overview	Overview displays status and current position of Photocell and Safety Edge (reversing edge)
Photocell 1: OK	1. To view status and current position of photocell
Safety Edge 1: OK	2. Safety Edge 2, scroll up.
Position: 123	

Position	Position shows the internal door position count. The battery level and status are shown
Position: 123	
Battery OK	

Inputs	Inputs provides an overview of the controller inputs. Box is marked if the corresponding controller input is active.
X2: <input type="checkbox"/> <input checked="" type="checkbox"/> <input type="checkbox"/> <input type="checkbox"/>	
X4: <input type="checkbox"/> <input type="checkbox"/> <input type="checkbox"/> <input type="checkbox"/> <input type="checkbox"/> <input type="checkbox"/> <input type="checkbox"/> <input type="checkbox"/>	

Outputs	Outputs provides an overview of the controller outputs. Box is marked if the corresponding controller output is active.
Relay: <input type="checkbox"/> <input type="checkbox"/> <input checked="" type="checkbox"/> <input type="checkbox"/>	
NPN: <input type="checkbox"/> <input checked="" type="checkbox"/>	

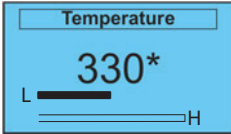
Log 1 of 10	Fault log displays error code and door operation cycle for the last 10 faults. Scroll up or down to navigate through the fault log.
Error: E10	
On Cycle: 045	

# SECTION 7 - MENUS 3 PHASE CONTROLLER (continued....)

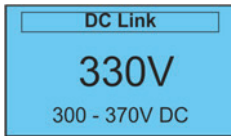
## PART 2 SYSTEM STATUS MENU (continued....)



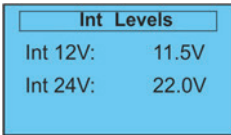
Cycle counter shows the number of operating cycles the door has completed (open/close = 1 cycle). Note: This is already shown by default at the top left corner in the main screen.



Temperature shows the internal temperature of the DGII Controller. This is a raw analog value and does not represent degrees centigrade or Fahrenheit. A display on the bottom graphically approximates either a Low or High temperature



DC Link shows the internal DC Link voltage along with the acceptable range.



INT Levels shows the control's actual internal supply voltages.

## SECTION 7 - MENUS 3 PHASE CONTROLLER (continued....)

### PART 3 PROFILE SELECTION MENU

The profile selection is done at the factory by default. Profiles can be selected based on the door the controller is operating. The profile is protected by a passcode, and can only be changed by Overhead service representative. All settings are lost and reverted back to defaults when the profile is changed. Profiles can be accessed through the main menu under Profile Selection.

### PART 4 LIMIT SETUP MENU

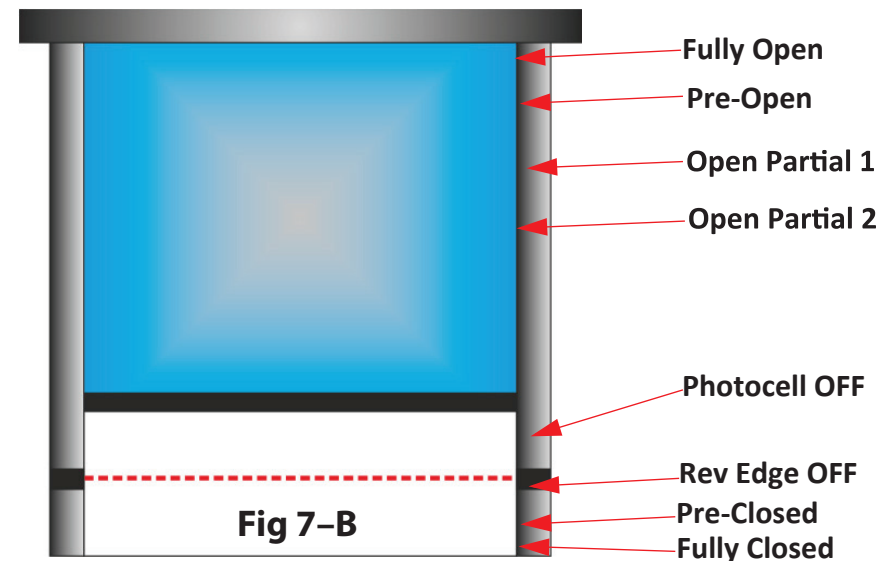
Individual limits can be updated manually, however; the best option is to use the quick setup process as discussed earlier. The door will not be operational when setting limits. Limit settings are as described below.

## ⚠ WARNING

All Entrapment Protection Devices are **OFF** when setting limits. Devices **OFF** while setting Limits include: Edge Contact, Photoeye, Wall push buttons, Radio Control, Limit Sensors, Loop Detector, or any motion sensor used as either an actuator or an Entrapment Protection Device. Only the Interlock remains active. **USE CAUTION! KEEP OPENINGS CLEAR OF PERSONS AND PROPERTY TO AVOID SERIOUS INJURY OR DEATH! Do NOT use for general door operation when setting limits.**

To configure the Limit Settings manually after using Quick Setup, select each individual position listed below from the Limit Setup menu, then move the door to the desired position. Store the position by pressing STOP or ENTER when finished. The display shows Stored and returns to the previous menu.

- Closed: Door fully closed.
- Pre Closed: Position where door changes to pre-closing speed during close.
- Pre Open: Position where door changes to pre-open speed during open.
- Open: Door fully closed.
- Open Part 1: Partially open position 1. Door opens to this position when a part 1 open input is active. (default: 75% of door open limit)
- Open Part 2: Partially open position 2. Door opens to this position when a part 2 open input is active. (default: 50% of door open limit)
- Rev. Edge OFF: Sets door position where safety edge check is turned off: the limit where the reversing safety edge should be ignored.
- Photocell Off: Sets door position where photocell should be ignored.



# SECTION 7 - MENUS 3 PHASE CONTROLLER (continued....)

## PART 5 SYSTEM CONFIGURATION MENU

This menu contains all editable parameters on the door system. A passcode is required in order to change the settings. The door will not operate when inside the menu.

### A. Timers

1. Contains all the same timers in the Express Menu.
2. Setting the timer to 0 disables the timer.

B. Outputs - Configurable relay activation based on custom door status/events. Table on page 44 lists all available status/events.

C. Inputs - Inputs with configurable actuator functions. Table on page 45 lists all functions available with each input.

D. Position sensor -Do not update/menu is not used

E. Reference -Do not update/menu is not used.

F. Safety Edges -Do not update / Menu not used.

G. Photoeyes -Do not update/menu is not used

H. Motor Configuration - Do not update / Engineering use only.

I. Frequencies - Do not update / Tech Services use only.

J. Ramps - Do not update / Tech Services use only.

K. DG-XNET -Do not update / Menu not used.

L. Options -Menu to access the pairing of the wireless sensing edge host.

M. System -Do not update / Engineering use only.

## CONFIGURATION INPUT/OUTPUTS

A. Inputs. There are 3 parameters that can be set. Refer to **FIG 7-C** (close up view of Input relays)

1. Function -A list of functions can be selected to determine how the input should operate the door.
2. Name -a name can be applied to the specific function
3. Logic -The logic for activation of the door can be chosen. Either Normally Open (0VDC ->24VDC) or Normally Closed (24VDC ->0VDC).

B. Outputs. Refer to **FIG 7-D** (close up view of Output relays)

1. Function -list of functions can be selected to activate the output relay
2. The output is dependent on the input wired into the relay pins 2, 5, 7, 9.
3. Output relays 1 & 2 consist of two relay outputs, a NO and NC. Output Relays 3 & 4 contain only NO relay activation.

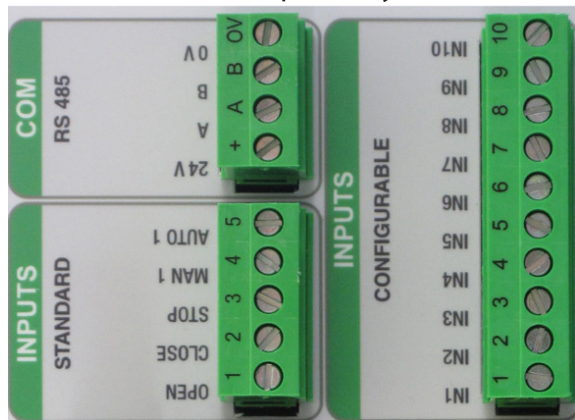


Fig 7-C

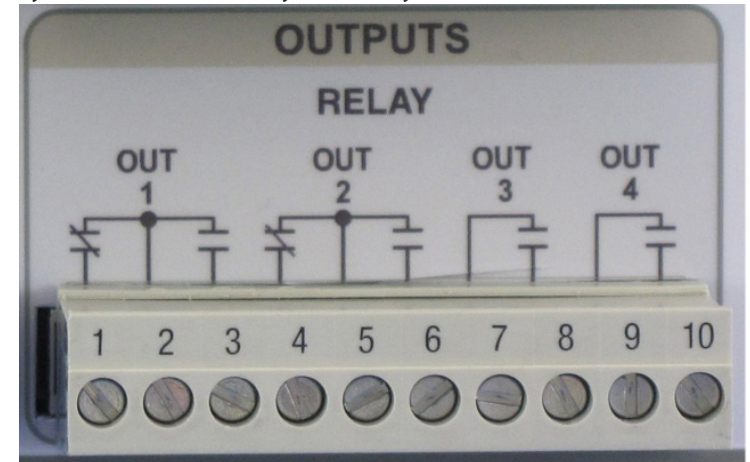


Fig 7-D

# SECTION 7 - MENUS 3 PHASE CONTROLLER (continued....)

## PART 5 SYSTEM CONFIGURATION MENU (continued....)

INPUT SIGNAL	ACTIVATION DESCRIPTION
Manual	Momentary activation opens door unless the door is already at an open position. In this case, the door will close. 1) If the Manual timer is set to a value greater than zero, the controller delays closing of the door until the timer expires.
Open	Opens the door to fully open position when activated.
Auto 1	Momentary activation opens door to the fully open position limit. Upon deactivation the controller delays the door for the duration of the Auto timer. If reactivated during this time delay, the timer will be reset and will begin to decrement when the input is again deactivated. Upon expiration of the timer, the controller closes the door to fully closed position. If timer is not used, the door will stay in the open position when activated.
Stop	Momentary activation stops the motion of the door. This input uses the Stop Deceleration Ramp set under the System Config menu. <b>This input is also used to clear certain error conditions.</b>
Close	Closes the door to fully open position when activated
Emergency Stop	Activation immediately halts the door in motion. <b>This input uses the Emergency Deceleration Ramp set under the System Config menu.</b>
Safety Edge	Activation during a closing cycle stops the door and then reverses the door motion back to the fully open position limit. An "E10 Safety Edge Activated" error occurs.
Photoeye	Activation during a closing cycle stops the door and then reverses the door motion back to the fully open position limit.
Lock Open	Activation causes the controller to hold the door at the fully open position limit. The input must be continuously activated to maintain the locked open state. Deactivating this input unlocks the door and allows normal operation.
Lock Close	Activation causes the controller to hold the door at the fully closed position limit. The input must be continuously activated to maintain the locked open state. Deactivating this input unlocks the door and allows normal operation.
Open Jog	Activation of this input moves the door in the direction of the fully open limit at Jog speed. Deactivating this input stops the door in motion. Activation during closing does not open or stop the door.
Close Jog	Activation of this input moves the door in the direction of the fully closed limit at Jog speed. Deactivating this input stops the door in motion. Activation during opening does not close or stop the door.
Breakaway	Activation halts door motion.
Open Position 1	Activation opens the door to the partial open 1 position limit. If activated during closing, door will reverse to 1 position limit.
Open Position 2	Activation opens the door to the partial open 2 position limit. If activated during closing, door will reverse to 2 position limit.
Open Part 1 Auto	Activation opens the door to partial open 1 position limit. The controller then delays the door for the duration of the Auto Timer. Upon expiration of the timer, the door closes fully.
Open Part 2 Auto	Activation opens the door to partial open 2 position limit. The controller then delays the door for the duration of the Auto Timer. Upon expiration of the timer, the door closes fully.
Flip Flop	Activation reverses the door operation. If door is closed, activation opens the door and vice versa. When door is closing and activated, the door reverses and begins opening and vice versa.
Man Part 1	Activation opens the door to the partial open 1 position limit, if not already at this position. If the door is already at this position, the door closes.
Man Part 2	Activation opens the door to the partial open 2 position limit, if not already at this position. If the door is already at this position, the door closes.

# SECTION 7 - MENUS 3 PHASE CONTROLLER (continued....)

## PART 5 SYSTEM CONFIGURATION MENU (continued....)

INPUT SIGNAL	ACTIVATION DESCRIPTION
Door Moving	Output is active when the door is in motion.
Door Not Moving	Output is active when the door is not in motion.
Door Open	Output is active when the door is at the fully open position.
Door Closed	Output is active when the door is at the fully closed position.
Door Not Closed	Output is active when the door is above the fully closed position.
Door Open Partial	Output is active when the door is at open part 1 position.
Door Opening	Output is active when the door is moving in the open direction.
Door Closing	Output is active when the door is moving in the close direction.
Delay to Close	Output is active when the Delay To Close timer is greater than zero and the door is commanded to close. The output remains active for the duration of the Delay To Close timer.
Delay to Open	Output is active when the Delay To Open timer is greater than zero and the door is commanded to open. The Open button must remain active until the Delay To Open timer has expired, the output will be active during this time. Upon expiration of the timer, the door opens and the output is deactivated.
Auto Close Active	Output is active for the duration of the Auto or Man timer during an auto close sequence.
System Error	Output is active when DGII is in any error condition.
Pre Warning Active	Output is active for the duration of the Auto Timer <b>and</b> during any close sequence.
Open Alarm Active	Output is active when Open Alarm Timer is greater then zero.

## SECTION 7 - MENUS 3 PHASE CONTROLLER (continued....)

### PART 6 INFORMATION MENU

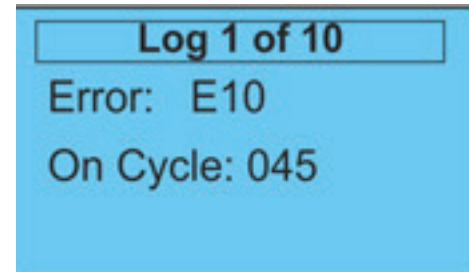
How to use the keypad to retrieve operation events, fault/shutdown messages, and system status (Also see Section 8—Troubleshooting)

- A. With the unit idle enter the System Status menu.
- B. Scroll through the list of choices until you reach the Fault Log menu and enter.
- C. Scroll through the list until you reach the information you're looking for.
- D. When finished exit the menus and return to the main screen.

**NOTE:** The items in the Fault Log are listed in reverse chronological order with number 1 being the most recent and the highest number being the oldest.

- If NO keys are pressed for 120 seconds, display will exit back to the main menu.
- Motion can occur and panel responds normally to inputs while in the System Status Menus.

## FAULT LOG



### PART 7 SETUP CHECK LIST

## ▲ WARNING

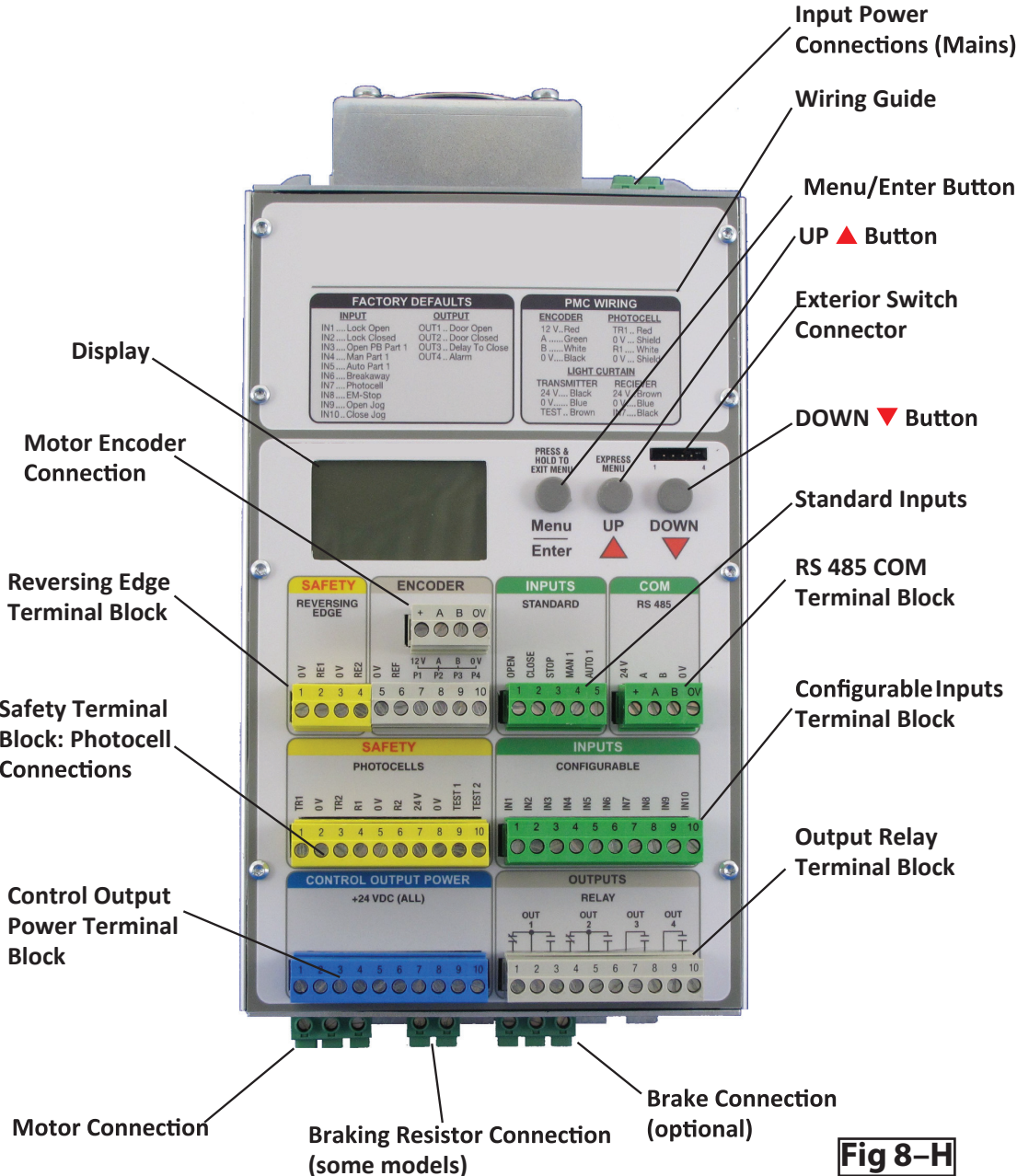
Check ALL items below to ensure that the Control Panel is installed and operating properly and entrapment protection is working properly. A door system that is not properly setup can cause death or serious injury.

### CHECK

- The door operates using all installed control devices.
- The door runs to its full open and full closed positions.
- The Entrapment Protection Device(s) will reverse a closing door when actuated.
- The proper Actuator selections are made to activate timers.
- The Hand Chain/Crank interlock switch prevents motor/door movement when the hand chain is pulled or crank handle inserted.

If the panel is in a location where public access is possible, install a means to limit access to the inside of the panel.

# SECTION 8 - TROUBLESHOOTING



**Fig 8-H**



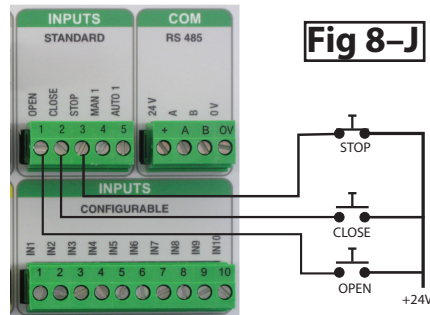
# SECTION 8 - TROUBLESHOOTING (continued....)

## PART 1 GENERAL TROUBLESHOOTING

TROUBLE	POTENTIAL CAUSE	NOTES / CORRECTIVE ACTION
Door will not move	Door may be in Shut Down mode. Fix issue.	Press stop key to clear fault.
	No power	Check motor wiring, power line, system rating.
Timed Close not functioning	Timer is set to 0.	Verify or update specific timer in express menu..
	Timer condition not met.	Verify door is at open close limits, or condition is met.
Auto 1/ Manual 1 Function not working	Wiring or connection loose, signal not reaching controller.	Verify connections.
	Auto 1/Man 1 not selected as function.	Verify chosen input function.
On key release, door stops or reverses	One of the sensor inputs activated.	Verify sensor inputs.
Timed Close quits after a few reverses	After a factory set number of failed attempts, usually three, the door will stop attempting to Time Close after a reversal. This is normal door function.	Door will reverse a Timed Closed door without counting the first reversal as a failed attempt. NOTE: If Entrapment Prevention Inputs cause reversals in the meantime, the reversals will continue to count as failed attempts and stop the close timer after three tries.
Wall push button not responding.	Wiring and firmware setting incorrect.	Common should be set to 24V Stop is set to NC in firmware (System config > Inputs) Open is set to NO. Close is set to NO. Refer to <b>Fig 8-J</b> page 42
General service Due: XXXXX	Routine service interval has elapsed.	Contact distributor for required maintenance.
Major service Req'd XXXXX	Required maintenance interval has elapsed.	Contact distributor for required maintenance.
Door stops for no reason, or acts differently than before - No errors displayed, only shows IDLE at status	A brownout or short has affected the controller	Use the disconnect switch to turn off the power, wait until the unit shuts off, then turn it back on (hard reset). -Contact customer service if it is still an issue.
	Possible overheat	Check fault log
One of the options to the Junction Box does not operate as expected	Connection to the Junction Box is incorrect	Ensure the Junction Box connections are correct (Via Manual) 1. Radio Remote Receiver is wired to Manual1 input -A 10 kohm load is also needed to be wired as instructed in FIG-23 pg 25 (three phase) or FIG 9.3 pg 48 (single phase). 2. Loop Detector or Motion Detector is wired to Option 1 (or to an Auto1 input) NOTE* Both can be wired, but one needs to be wired directly to the Control Unit (regular wire can be used)
Quick setup aborted	Fault occurred when setting limits	1. Fix faults in system. 2. Make sure Position Sensor does not roll over from +32,000 to -32,000 when setting limits. 3. Make sure Position count increases when setting door to open limit (door direction incorrect). 4. Restart Quick Setup.
Door limits have shifted	Position Sensor fault/failure	1. Verify Position Sensor connections. 2. Reset limits.

# SECTION 8 - TROUBLESHOOTING (continued....)

## PART 2 CONTROL PANEL STATUS MESSAGES



MESSAGE DISPLAYED	CAUSE	NOTES / CORRECTIVE ACTION
-----	Displayed if no message code is present in the Event or Error Log.	Contact service representative.
<b>STATUS</b>		
Idle	Door at rest, not at open, close, mid limits.	Displayed when door is motionless in Idle and not at open, close, open P1 limits. Door stopped using the STOP key.
<b>STATUS</b>		
Count down	Door at rest and counting down to timed close or open.	Time remaining in seconds is displayed.
<b>STATUS - OPENING</b>		
Opening	Door opening.	Displayed while door is opening from activation.
<b>STATUS - CLOSING</b>		
Closing	Door closing.	Displayed while door is closing from activation.
<b>STATUS - STOP</b>		
Stop	Door stopping.	Displayed while door is stopping from activation.
<b>STATUS</b>		
Locked	Incorrect pass code input.	Displayed when the wrong pass code is entered
Closed	Position at close limit.	
Open	Position at open limit.	
Open P1	Position at 75% of open limit.	
Open P2	Position at mid limit.	

# SECTION 8 - TROUBLESHOOTING (continued....)

## PART 3 CONTROL PANEL ERROR MESSAGES - INVERTER ERROR CODES

CODE	DESCRIPTION	PROBLEM	POSSIBLE SOLUTION
INV_ERROR_UU	DC Link low (Top Priority)	The incoming mains voltage is too low	View System Status - DC Link to check that the voltage is within the range shown.
INV_ERROR_OU	DC Link high (Medium Priority)	Either the incoming mains voltage is too high or the deceleration rate is too short	View System Status - DC Link to check that the voltage is within the range shown. Decrease the deceleration ramps.
INV_ERROR_OC1	Overcurrent 210% (Low Priority)	The motor current exceeds the inverter rating by 210%	View the Motor Current display to check the current delivered to the motor. Check the motor nameplate data to confirm that the correct controller model is being used. Check for mechanical obstruction or damage.
INV_ERROR_OC2	Overcurrent 150%/30 sec (Low Priority)	The motor current exceeds the inverter rating by 150% for more than 30 seconds	View the Motor Current display to see the current delivered to the motor. Check the motor nameplate data to confirm that the correct controller is being used. Check for mechanical obstruction or damage.
INV_ERROR_OC3	Overcurrent during acceleration	Overcurrent while accelerating	View the Motor Current display to see the current delivered to the motor. Decrease the acceleration ramps
INV_ERROR_OC4	Overcurrent DC/Brake (Medium Priority)	Overcurrent while DC braking	View the Motor Current display to see the current delivered to the motor. Decrease the DC Brake level.
INV_ERROR_OC5	Peak overcurrent (High Priority)	Severe overload	Check for: a short in the motor cable stalled motor mechanically or electrically damaged motor. If equipped with a parking brake, ensure that it is being released. Decrease the Boost parameters.
INV_ERROR_OH	Controller overheat (High Priority)	The inverter is overheated	View System Status - Temperature to check that the reported temperature is within range. Check ventilation and ensure fan, if present, is operating. Reset the controller and confirm that the fan operates for 1 second during the power-up routine. Reduce the duty cycle of the door.
INV_ERROR_12V	Low internal 12v (Top Priority)	The internal 12V DC power supply voltage is too low	View the System Status - Int Levels to check that the voltage is within range. Check I/O wiring for shorts.
INV_ERROR_24V	Low internal 24v (Top Priority)	The internal 24V DC power supply voltage is too low	View the System Status - Int Levels to check that the voltage is within range. Check I/O wiring for shorts.

# SECTION 8 - TROUBLESHOOTING (continued.....)

## PART 4 CONTROL PANEL ERROR MESSAGES - DOOR CONTROL ERROR CODES

CODE	DESCRIPTION	PROBLEM	POSSIBLE SOLUTION
E01	Slip error (Low Priority)	Mechanical overload (Slip Monitoring) or missing signal from encoder.	Check door for obstruction. Ensure the pulse output from the encoder is connected to terminal P2 on the controller. Verify that the encoder pulse output is set correctly.
E02	Direction Error - occurs during setup only (Low Priority)	The direction of the motor is incorrect. The encoder count must increment positively while the door is moving in the open direction.	Use the Motor Direction parameter to set the correct direction for the motor and encoder.
E03	No Signal From Pulse Generator - occurs during setup only. (Low Priority)	No pulse input detected from the encoder.	Check door for obstruction. Ensure the pulse output from the encoder is connected to terminal P2 on the Controller. Verify that the encoder pulse output is set correctly.
E04	Speed Error	Door moves faster/slower than Expected	Check door for obstruction.
E05	N/A		
E06	N/A		
E07	Run Timer Exceeded (Low Priority)	The Run Timer has expired.	Check the Run Timer parameter to ensure a correct value.
E08	Safety Edge Test Fail (Medium Priority)	The Reversing Edge test has failed	Check the connections from the reversing edge to the controller. If using the Seywave wireless system, check operation of connected host and remote door sensor.
E09	Safety Edge Connection (Medium Priority)	The Reversing Edge connection cannot be verified.	Check the connections from the reversing edge to the controller. If using the Seywave wireless system, check operation of connected host and remote door sensor. Verify Safety edge is not activated.
E10	Safety Edge 1 Activated (Low Priority)	The Reversing Edge has been activated	Check for obstruction in door's path.
E11	Safety Edge 2 Activated (Low Priority)	The Reversing Edge has been activated	Check for obstruction in door's path.
E12	Lifting Force Exceeded (Low Priority)	The torque limit has been exceeded	If the torque limiting feature is being used, adjust the Torque Limit parameter to suit the application.
E13	No Encoder movement	Encoder did not move when expected	Check for obstruction. Check connection from Position Sensor to Motor.
E14	Absolute Encoder Comm Loss (Top Priority)	Communication with the absolute encoder has been lost.	Check the connections between the encoder and the controller.
E15	Installation Fault (Low Priority)	An error occurred during Quick Setup	Re-perform Quick Setup
E16	Encoder fault	Encoder communication is not correct	Check Position Sensor. Verify connections.

# SECTION 8 - TROUBLESHOOTING (continued.....)

## PART 4 CONTROL PANEL ERROR MESSAGES - DOOR CONTROL ERROR CODES (continued.....)

CODE	DESCRIPTION	PROBLEM	POSSIBLE SOLUTION
E17	Reset Limits (HIGH PRIORITY)	The position limits cannot be verified	Perform a Quick Setup
E18	Wireless Airlock Failed to Authorize Opening (Low Priority)	The controller failed to receive an Airlock request acknowledgement.	Check opposite controller to ensure that it is operational. Check that both controllers have been wirelessly connected together and that each controller has Wireless and Airlock enabled. Disconnect controllers and run a discovery to reconnect controllers.
E19	Wireless No Response	There was no response from the onboard wireless	Ensure that the Wireless is Enabled then power cycle the controller.
E20	Backroll error	Door movement when at idle state	Verify there are no obstructions, verify motor gear box is functional.
E21	Option - Seywave OCS Remote Timeout	A paired Seywave wireless O/C/S remote has timed out.	Check the remote for operation. Refer to supplied Seywave Wireless manual for troubleshooting.
E22	Option - Seywave DS Remote Timeout	A paired Seywave wireless Door Sensor remote has timed out.	Check the remote for operation. Refer to supplied Seywave Wireless manual for troubleshooting.
E23	Option - Seywave DS Connection Fault	A paired Seywave wireless Door Sensor remote has reported a connection fault.	Check the connection and remote for operation. Refer to supplied Seywave Wireless manual for troubleshooting.
E24	N/A		
E25	Manual Crank input active (Medium Priority)	The hand chain has been pulled or crank handle inserted.	Pull the hand chain in the opposite direction or remove crank handle to reset.
E26	Overtravel error (HIGH PRIORITY)	Door moves beyond limits.	Reset limits
E27	Photoeye connection test fail (Medium Priority)	Monitored Photoeye connection test failed.	Check photoeye connections
E28	Photoeye 1 activation (Low Priority)	Photoeye 1 has detected an obstruction.	Check for obstructions in photoeye path
E29	Photoeye 2 activation (Low Priority)	Photoeye 2 has detected an obstruction	Check for obstructions in photoeye path
E30	Input Timer Exceeded	Input activation lasting longer than 2 minutes.	Verify wall buttons are not stuck. Check connections for a short.

## PART 5 CONTROL PANEL ERROR MESSAGES - ERROR CODE PRIORITY LEVELS

Priority Level	Reset Condition	Comment
Low	Activation input	Can also be reset by higher priority reset conditions
Medium	Stop, E-Stop or Menu/Enter button pressed	Can also be reset by higher priority reset conditions
High	Menu/Enter button pressed and held for 2 seconds.	Screen Flashes
Priority Reset Limits	Successful Quick Setup	Auto-clears when limits are set
Priority Encoder Connection	Communication restored between encoder and controller	Auto-clears when fault no longer exists
Priority INV_ERROR_UU	Incoming main voltage is within range	Auto-clears when fault no longer exists
Priority INV_ERROR_12VInternal 12V	Internal 12V DC level is within range	Auto-clears when fault no longer exists
Priority INV_ERROR_24V	Internal 24V DC level is within range	Auto-clears when fault no longer exists

# SECTION 9 - LOW VOLTAGE WIRING - SINGLE PHASE CONTROLLER

## STEP 1 CONNECT CONTROLLER LOW VOLTAGE WIRING (EXTERNAL)

Connections to the door are completed by attaching the two screw-in cables to the control panel's base, Fig 19 page 22.

-5 pin cable connector (See Fig 22 and 22 on page 24)

- Position Sensor

-12 pin cable connector (See Fig 19 on page 22)

- Photoeye Receiver
- Photoeye Transmitter
- Sensing Edge
- Hand Crank Interlock Switch
- Optional Input 1
- Optional Input 2

## STEP 2 INSTALL OPTIONAL DEVICES

### INSTALL MOTION SENSOR (optionally purchased)

Motion Sensor is an optional component purchased separately and does **not** come with door.

- Follow the installation instructions accompanying the Motion Sensor.
- Install wiring per wiring diagram FIG 24 page 25.

### INSTALL LOOP DETECTOR (optionally purchased)

Loop Detector is an optional component purchased separately and does **not** come with door.

- Follow the installation instructions accompanying the Loop Detector.
- Install wiring per wiring diagram FIG 25 page 25.

### INSTALL RADIO CONTROLS (optionally purchased)

Radio Controls are an optional component purchased separately and does **not** come with door.

- Follow the installation instructions accompanying the Radio Controls.
- Install wiring per wiring diagram FIG 9.3 page 48.

### INSTALL WALL MOUNTED PUSH BUTTON (optionally purchased)

Wall Mounted Push Buttons are an optional component purchased separately and does **not** come with door.

- Install wiring per wiring diagram FIG 12.4 page 62.

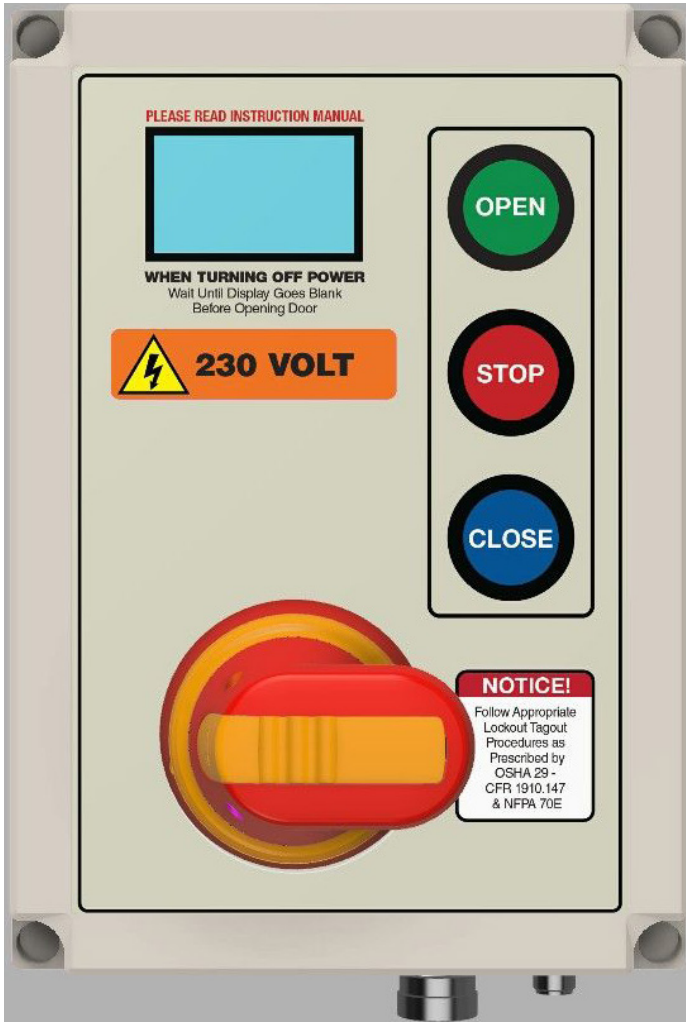
## STEP 3 CONNECT OPTIONAL DEVICES

One option may be connected to the Junction Box by the installer. Additional options must be wired to the spare inputs on the Control panel. Use the corresponding option inputs.

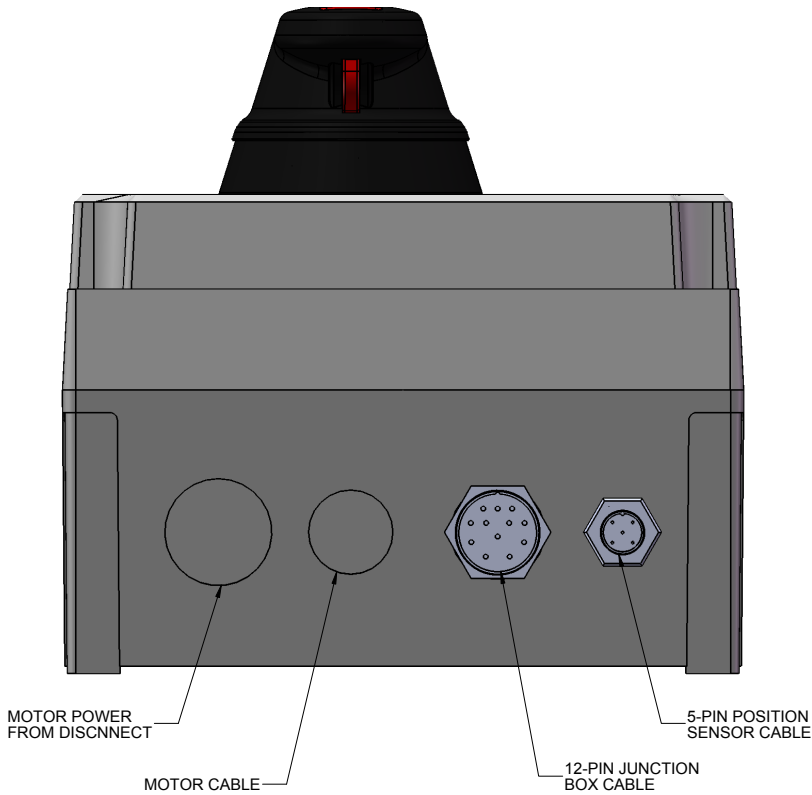
- Radio Remote to the Junction Box connector 5 labeled "Option 1".
- Floor loop to the Junction Box connector 5 labeled "Option 1".
- Motion Detector to the Junction Box connector 5 labeled "Option 1".
- Wall mounted push button stations to the main Control Panel Fig. 12.4 on page 62.

**Note:** When installing push buttons, use the 24V supplied by the Control Unit as the common.

# SECTION 9 - LOW VOLTAGE WIRING - SINGLE PHASE (continued.....)



**Fig 9.1**

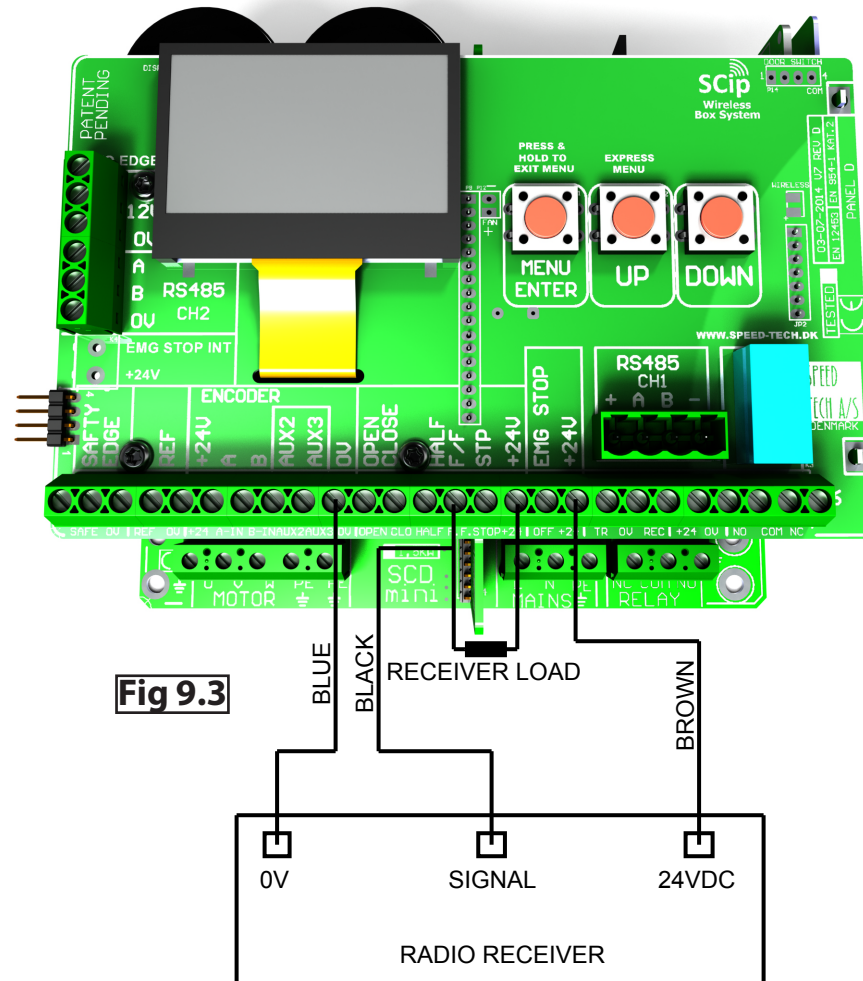


**Fig 9.2**

# SECTION 9 - LOW VOLTAGE WIRING - SINGLE PHASE (continued.....)

## REFERENCE MATERIALS LOCATION

1. For a diagram of the pin layouts on the 5-pin and 12-pin cables and connectors see FIG-19 pg 22.
2. For a diagram of the junction box connectors see FIG-20 pg 23.
3. For position sensor location and cable details see FIG-21 and FIG-22 pg 24.
4. For radio receiver wiring see FIG-9.3 below.
5. For motion detector and loop detector wiring see FIG-24 and FIG-25 pg 25.





## SECTION 10 - HIGH VOLTAGE WIRING - SINGLE PHASE

### ⚠ WARNING

Before beginning this phase of the installation, ensure power supply is **DISCONNECTED!**

### ⚠ CAUTION

ADV-X Door Models must be supplied by a grounded voltage supply. Ungrounded voltage supply sources should **NOT** be used. Voltage unbalance is a common occurrence on systems, which power both single phase and three phase loads, which can lead to unequal voltages on each phase leg. Voltage unbalance can cause deterioration of motor performance, such as loss of torque, overheating, decrease the winding insulation life, and can cause motor starter contacts, to permanently “weld” closed. Voltage unbalance can be caused by inadequate conductor sizing, transformer sizing, excessive single-phase loads, poor grounding, or intermittent high resistance faults (Faults which do NOT generate high – enough fault currents to trip an Over Current Protection device, but will cause the distributed capacitance in an ungrounded three phase system to shift. This shift may cause destructive over-voltages to occur). Any single phase loads should be evenly distributed as much as possible between the 3 phases. Consult a licensed electrician if you have any questions

***Overhead Door Corporation's warranty WILL NOT cover damage caused by failure of the motor, control panel or other electrical components due to the use of an inadequately grounded system.***

ADV-X models 880 and 881 are available in single phase and 3-phase voltages. Single phase voltages are available in 110-120VAC and 220-240VAC. 3 phase voltages are available in 240VAC, 480VAC, and 575VAC. ADV-X model 882, 883, 884, and 885 are available in 3 phase voltages only. **YOUR LOCAL CODES MAY REQUIRE THAT THE INCOMING POWER TO YOUR DOOR HAVE A LOCK-OUT / TAG-OUT EQUIPPED FUSED DISCONNECT SWITCH (TO BE FURNISHED BY OTHERS) WITHIN EYESIGHT OF THE DOOR'S CONTROL PANEL.** Incoming power wiring must meet all NEC and local building codes, plus be properly sized for the control panel's amperage rating on the nameplate. To reduce the risk of electric shock, the chassis of the control panel must be properly grounded.

### ⚠ WARNING

To avoid serious injury or death:

- It is recommended that line voltage wiring be performed by a qualified electrician.
- Be sure that electrical power has been disconnected from the input wires being connected to the operator prior to handling these wires. An appropriate lock-out/tag-out procedure is recommended.
- Line voltage must meet all local building codes.
- Make sure operator voltage, phase, and frequency ratings are identical to the job site line voltage ratings.
- Input power wiring must be properly sized for the operators amperage rating.

### ⚠ WARNING

To avoid serious injury or death DO NOT calibrate motor or operate door unless doorway is in sight and free of obstructions. Keep clear of opening while door is moving.

## SECTION 10 - HIGH VOLTAGE WIRING - SINGLE PHASE (continued....)

**MOTOR & POWER WIRING (HIGH VOLTAGE)** (These tasks are also diagrammed in Fig 10.1, 10.2, and 10.3 on pages 50-52.)

- A.** Route **Motor Power Cable** (provided, factory wired to motor) through water-tight fitting in the FIRST hole from left side of Control Panel bottom.
1. Connect the lighter gauge, twisted pair wires to the blue colored **Motor Brake** terminals next to the disconnect switch. Either wire can connect to either terminal. It is labeled "B1" and "B2".
  2. Connect the green and yellow ground wire and the braided cable shield separately to the two PE terminals on the PCB.
  3. Connect the thicker motor wires to Terminals U, V and W on the green screw connectors on the bottom left of the PCB. The order doesn't matter since the motor rotation can be changed using the internal programming during Set-up in **Section 6**.

### ⚠ WARNING

Before beginning this phase of installation, ensure POWER SUPPLY is disconnected!

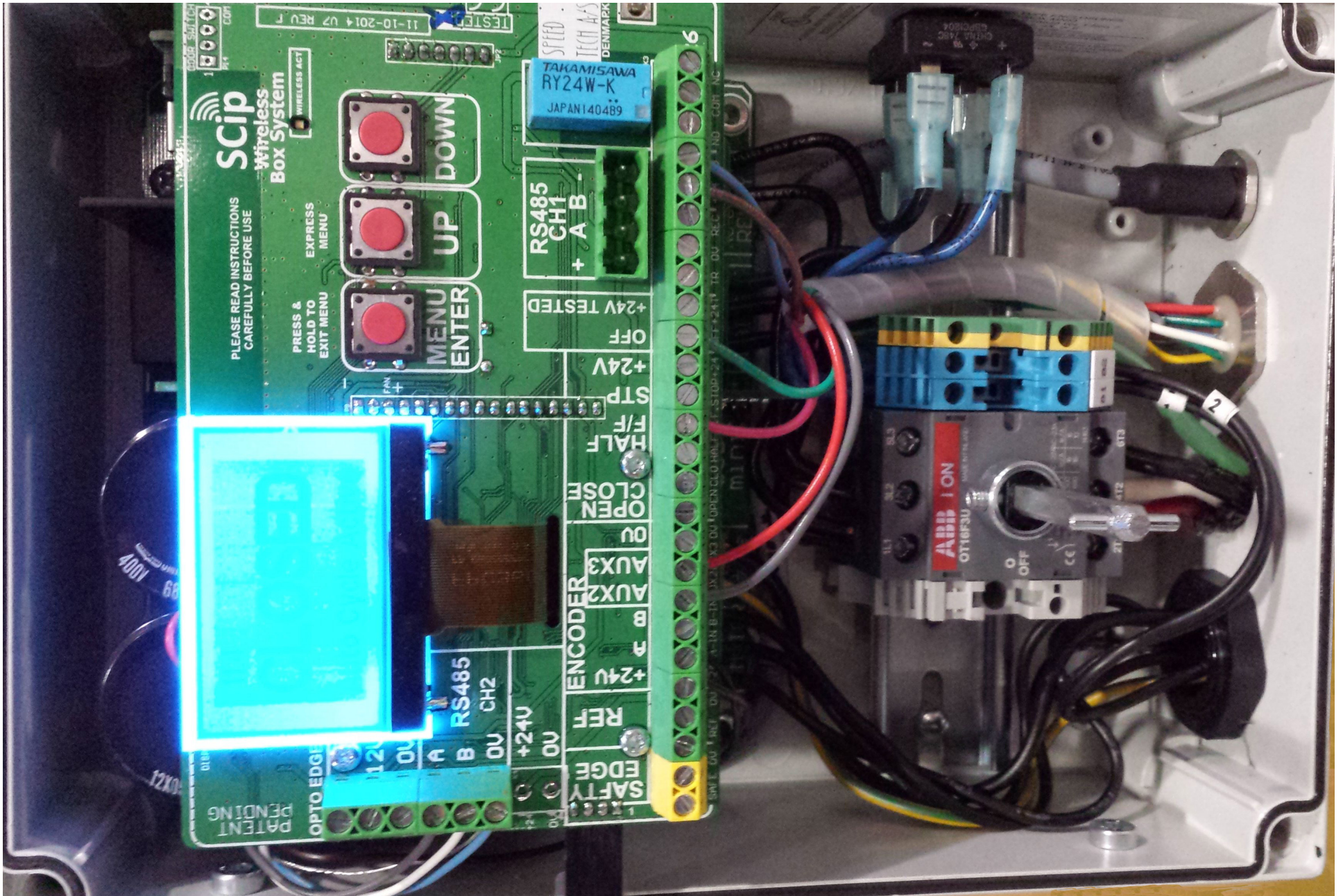
**A licensed electrician must perform the following step.**

- B.** Route **Main Power Cable** (not provided) through a water-tight fitting (not provided) in the SECOND hole from the left side of the Control Panel bottom.
- Connect single phase power lines to the disconnect. Connect the ground wire to the Ground Terminal to the left of the disconnect.



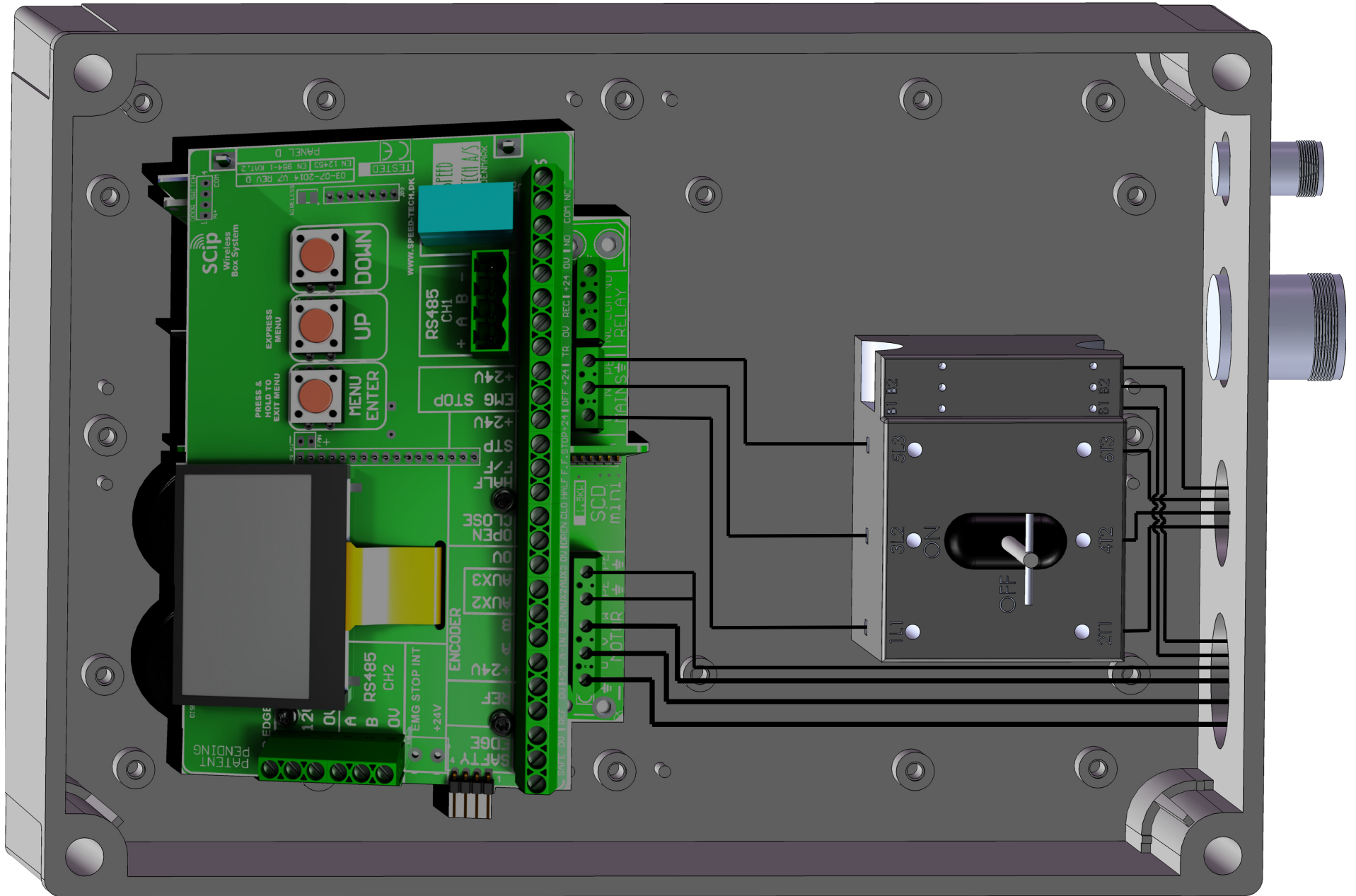
**Fig 10.1**

# SECTION 10 - HIGH VOLTAGE WIRING - SINGLE PHASE (continued....)



**Fig 10.2**

# SECTION 10 - HIGH VOLTAGE WIRING - SINGLE PHASE (continued....)

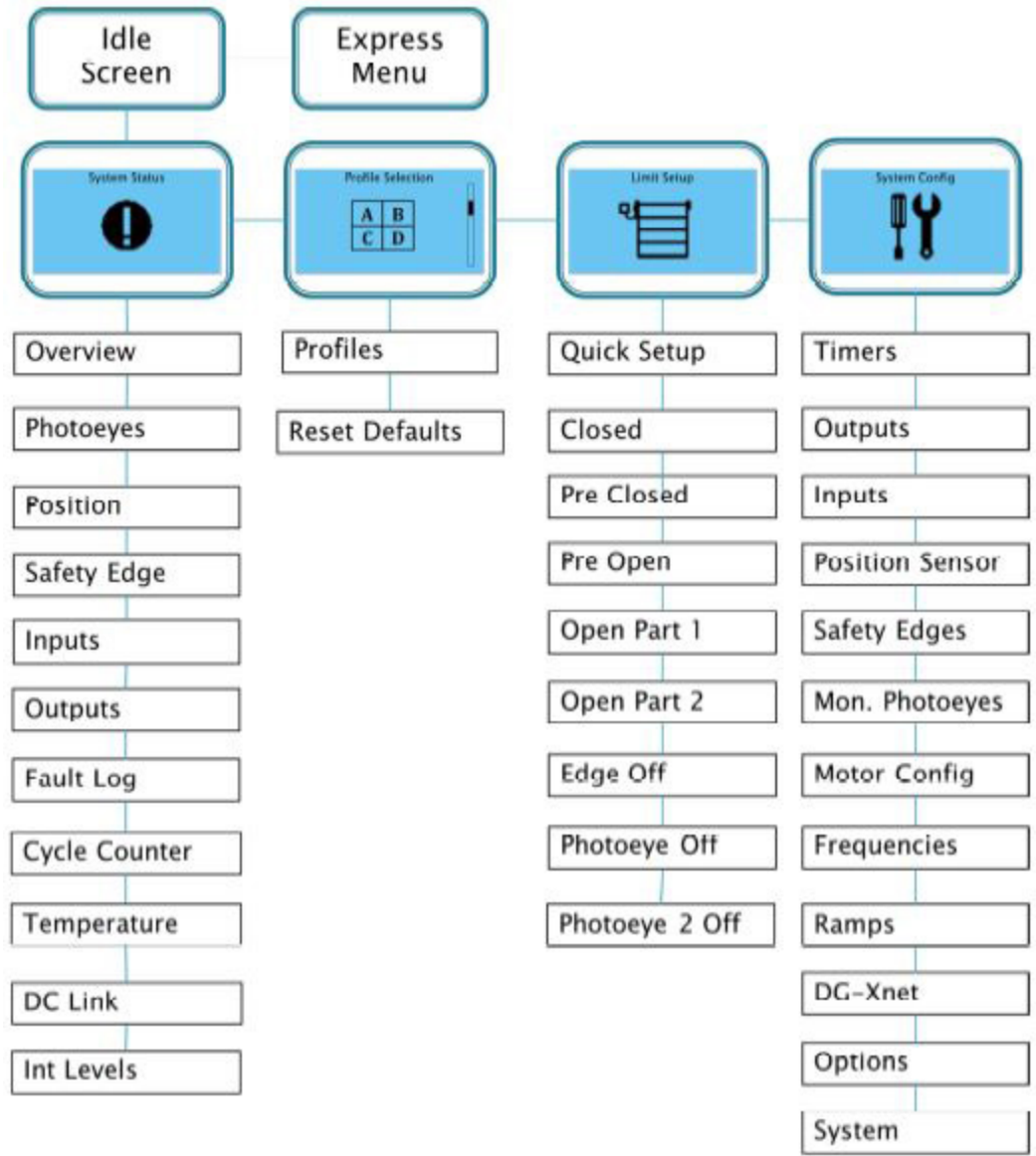


# SECTION 11 - INITIAL STARTUP PROCEDURE- SINGLE PHASE

## REFERENCE MATERIALS LOCATION

Initial startup procedure is identical to the procedure for the three phase controller. Please refer to section 6 pg 30-31.

# SECTION 12 - MENUS - SINGLE PHASE CONTROLLER



**Fig 12.1**

# SECTION 12 - MENUS - SINGLE PHASE CONTROLLER (continued.....)

## PART 2 SYSTEM STATUS MENU

The System Status menu is read-only and provides parameter status displays for use in setup and troubleshooting. The options of the System Status menu are shown and described below. The controller is fully operational within this menu, allowing real-time parameter updates. To use the System Status menu:

- A. Enter the System Status menu
- B. Scroll down and highlight a menu option.
- C. Enter to view the highlighted option.
- D. Press and hold STOP or ENTER when finished to return to the System Status menu.
- E. Repeat to view other parameters if desired.

Overview	Overview displays status and current position of Photocell and Safety Edge (reversing edge)
Photocell 1: OK	1. To view status and current position of photocell
Safety Edge 1: OK	2. Safety Edge 2, scroll up.
Position: 123	

Position	Position shows the internal door position count. The battery level and status are shown
Position: 123	
Battery OK	

Inputs	Inputs provides an overview of the controller inputs. Box is marked if the corresponding controller input is active.
X2: <input checked="" type="checkbox"/> <input type="checkbox"/> <input type="checkbox"/> <input type="checkbox"/>	
X4: <input type="checkbox"/> <input type="checkbox"/> <input type="checkbox"/> <input type="checkbox"/> <input type="checkbox"/> <input type="checkbox"/> <input type="checkbox"/> <input type="checkbox"/>	

Outputs	Outputs provides an overview of the controller outputs. Box is marked if the corresponding controller output is active.
Relay: <input type="checkbox"/> <input checked="" type="checkbox"/> <input type="checkbox"/> <input type="checkbox"/>	
NPN: <input checked="" type="checkbox"/>	

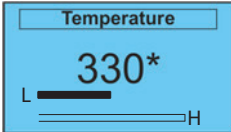
Log 1 of 10	Fault log displays error code and door operation cycle for the last 10 faults. Scroll up or down to navigate through the fault log.
Error: E10	
On Cycle: 045	

# SECTION 12 - MENUS - SINGLE PHASE CONTROLLER (continued.....)

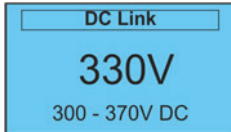
## PART 2 SYSTEM STATUS MENU (continued.....)



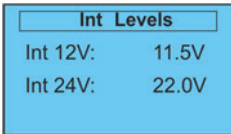
Cycle counter shows the number of operating cycles the door has completed (open/close = 1 cycle). Note: This is already shown by default at the top left corner in the main screen.



Temperature shows the internal temperature of the DGII Controller. This is a raw analog value and does not represent degrees centigrade or Fahrenheit. A display on the bottom graphically approximates either a Low or High temperature



DC Link shows the internal DC Link voltage along with the acceptable range.



INT Levels shows the control's actual internal supply voltages.



# SECTION 12 - MENUS - SINGLE PHASE CONTROLLER (continued....)

## PART 3 PROFILE SELECTION MENU

The profile selection is done at the factory by default. Profiles can be selected based on the door the controller is operating. The profile is protected by a passcode, and can only be changed by Overhead service representative. All settings are lost and reverted back to defaults when the profile is changed. Profiles can be accessed through the main menu under Profile Selection.

## PART 4 LIMIT SETUP MENU

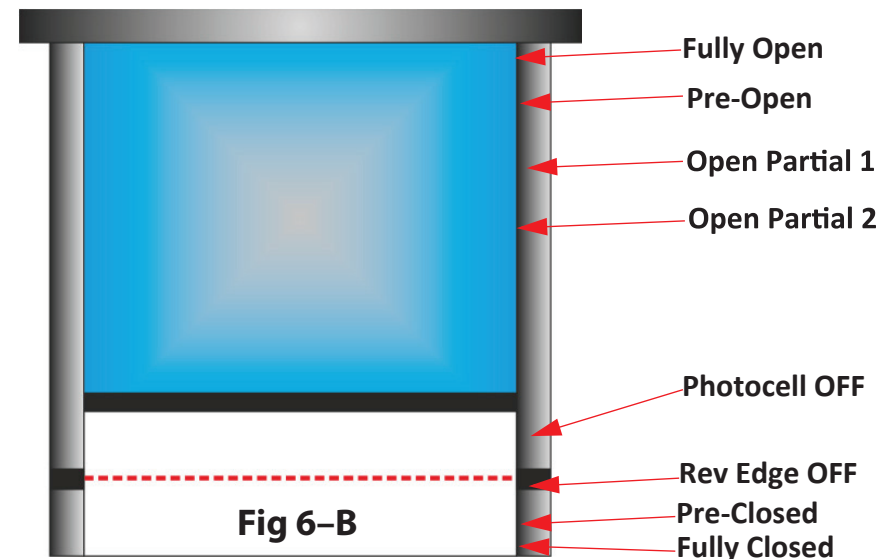
Individual limits can be updated manually, however; the best option is to use the quick setup process as discussed earlier. The door will not be operational when setting limits. Limit settings are as described below.

### ⚠ WARNING

All Entrapment Protection Devices are **OFF** when setting limits. Devices **OFF** while setting Limits include: Edge Contact, Photoeye, Wall push buttons, Radio Control, Limit Sensors, Loop Detector, or any motion sensor used as either an actuator or an Entrapment Protection Device. Only the Interlock remains active. **USE CAUTION! Do NOT use for general door operation when setting limits.**

To configure the Limit Settings manually after using Quick Setup, select each individual position listed below from the Limit Setup menu, then move the door to the desired position. Store the position by pressing STOP or ENTER when finished. The display shows Stored and returns to the previous menu.

- Closed: Door fully closed.
- Pre Closed: Position where door changes to pre-closing speed during close.
- Pre Open: Position where door changes to pre-open speed during open.
- Open: Door fully closed.
- Open Part 1: Partially open position 1. Door opens to this position when a part 1 open input is active. (default: 75% of door open limit)
- Open Part 2: Partially open position 2. Door opens to this position when a part 2 open input is active. (default: 50% of door open limit)
- Rev. Edge OFF: Sets door position where safety edge check is turned off: the limit where the reversing safety edge should be ignored.
- Photocell Off: Sets door position where photocell should be ignored.



# SECTION 12 - MENUS - SINGLE PHASE CONTROLLER (continued....)

## PART 5 SYSTEM CONFIGURATION MENU

This menu contains all editable parameters on the door system. A passcode is required in order to change the settings. The door will not operate when inside the menu.

### A. Timers

1. Contains all the same timers in the Express Menu.
2. Setting the timer to 0 disables the timer.

B. Outputs - Configurable relay activation based on custom door status/events. Table on page 55 lists all available status/events.

C. Inputs - Inputs with configurable actuator functions. Table on page 55-56 lists all functions available with each input.

D. Position sensor -Do not update/menu is not used

E. Reference -Do not update/menu is not used.

F. Safety Edges -Do not update / Menu not used.

G. Photoeyes -Do not update/menu is not used

H. Motor Configuration - Do not update / Engineering use only.

I. Frequencies - Do not update / Tech Services use only.

J. Ramps - Do not update / Tech Services use only.

K. DG-XNET -Do not update / Menu not used.

L. Options -Menu to access the pairing of the wireless sensing edge host.

M. System -Do not update / Engineering use only.



**Fig 12.2**



**Fig 12.3**

### CONFIGURATION INPUT/OUTPUTS

A. Inputs. There are 3 parameters that can be set. Refer to **FIG 12.2** (close up view of Input relays)

1. Function -A list of functions can be selected to determine how the input should operate the door.
2. Name -a name can be applied to the specific function
3. Logic -The logic for activation of the door can be chosen. Either Normally Open (0VDC ->24VDC) or Normally Closed (24VDC ->0VDC).

B. Outputs. Refer to **FIG 12.3** (close up view of Output relays)

- 1 Function -list of functions can be selected to activate the output relay
2. The output is dependent on the input wired into the relay pins.

Standard Input Configuration*				
Input Terminal #	Input Label	Default function	Default Name	Default Logic
8	Aux 2	Photoeye1	Photoeye1	Normally Closed
9	Aux 3	Photoeye2	Photoeye2	Normally Closed
11	Open	Open	Open	Normally Open
12	Close	Close	Close	Normally Open
13	Partial	Open Part 1	Open Part 1	Normally Open
14	Auto	Auto 1	Auto 1	Normally Open
15	Stop	Stop	Stop	Normally Closed
17	Off	Hand Crank	Hand Crank	Normally Closed

\*For reference only, may change based on profile

# SECTION 12 - MENUS - SINGLE PHASE CONTROLLER (continued.....)

## INPUT FUNCTIONS

MENU ITEM	Description: (when the input is active)
<input type="checkbox"/> No Function	Input is disabled.
<input type="checkbox"/> Manual 1	An activation of this input will open the door unless the door is already at an open position. In this case the door will close. If the Man 1 Timer is set greater than zero the controller will delay closing of the door until the timer has expired.
<input type="checkbox"/> Open	An activation of this input will open the door to the Fully Open position.
<input type="checkbox"/> Auto 1	An activation of this input will open the door to the Fully Open position. The controller will then delay the door for the duration of the Auto 1 Timer. Upon expiration of the timer the controller will then close the door to the Closed Position.
<input type="checkbox"/> Stop	Activation of this input will stop motion of the door. This input is also used to clear certain error conditions.
<input type="checkbox"/> Close	An activation of this input will close the door to the fully close position.
<input type="checkbox"/> Emergency Stop	An activation of this input will cause the door to immediately stop motion.
<input type="checkbox"/> Safety Edge	An activation of this input during a closing cycle will cause the door to stop motion and then reverse to the Fully Open position. This will also cause an E10 error "Safety Edge Activated".
<input type="checkbox"/> Photoeye 1	An activation of this input during a closing cycle will cause the door to stop motion and then reverse to the Fully Open position. This will also cause an E28 error "Photoeye 1 Activated".
<input type="checkbox"/> Lock Open	Activation of this input will cause the controller to hold the door at the Fully Open position. The input must be continually activated to hold the controller in the Locked state. A deactivation of this input will unlock the door and allow normal operation.
<input type="checkbox"/> Lock Close	Activation of this input will cause the controller to hold the door at the closed position. The input must be continually activated to hold the controller in the Locked state. A deactivation of this input will unlock the door and allow normal operation.
<input type="checkbox"/> Open Jog	Continuous activation of this input will move the door in the open direction at Jog Speed. A deactivation of the input will stop motion of the door.
<input type="checkbox"/> Close Jog	Continuous activation of this input will move the door in the Closed direction at Jog Speed. A deactivation of the input will stop motion of the door.

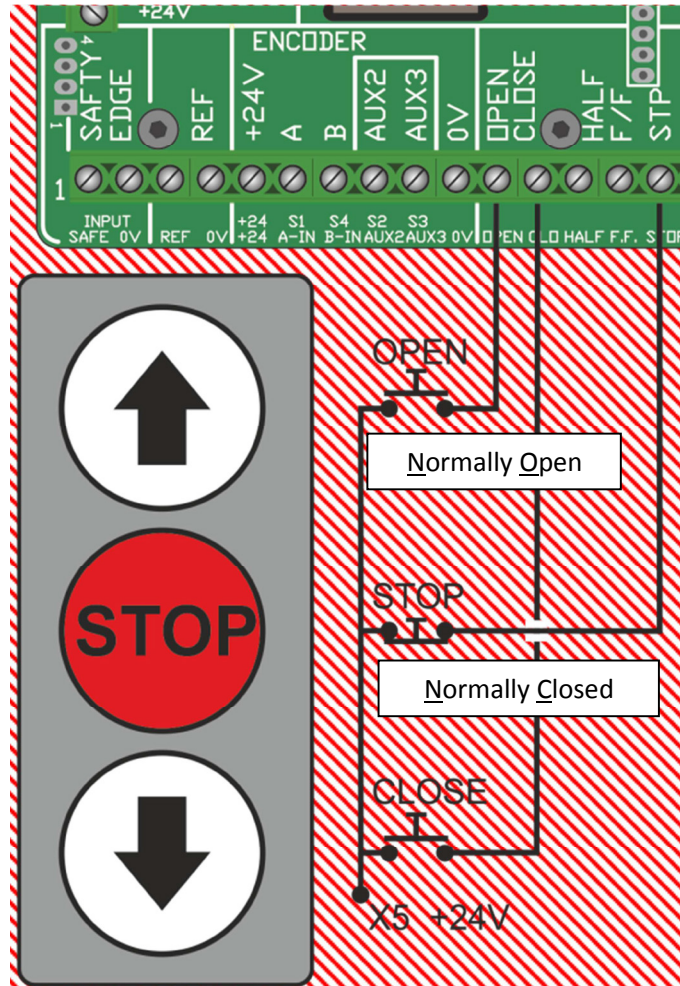
## SECTION 12 - MENUS - SINGLE PHASE CONTROLLER (continued.....)

<input type="checkbox"/> <b>Breakaway</b>	<p>Activation of this input will stop motion of the door. This will also cause an E31 error "Breakaway Active". A Breakaway reset procedure will be required. See the Trouble Shooting section for details.</p>
<input type="checkbox"/> <b>Open Part 1</b>	<p>Activation of this input will open the door to the Open Part 1 position.</p>
<input type="checkbox"/> <b>Open part 2</b>	<p>Activation of this input will open the door to the Open Part 2 position.</p>
<input type="checkbox"/> <b>Auto 1 Part 1</b>	<p>Activation of this input will open the door to the Open Part 1 position. The controller will then delay the door for the duration of the Auto 1 Timer. Upon expiration of the timer the door will close to the Fully Closed position.</p>
<input type="checkbox"/> <b>Auto 1 Part 2</b>	<p>Opens the door to the Partial 2 position and starts the Auto Close Timer. Activation of this input will open the door to the Open Part 2 position. The controller will then delay the door for the duration of the Auto 1 Timer. Upon expiration of the timer the door will close to the Fully Closed position.</p>
<input type="checkbox"/> <b>Photoeye 2</b>	<p>An activation of this input during a closing cycle will cause the door to stop motion and then reverse to the Fully Open position. This will also cause an E29 error "Photoeye 2 Activated".</p>
<input type="checkbox"/> <b>Man 1 Part 1</b>	<p>Activation of this input will open the door to the Open Part 1 position if the door is not at this position. If the door is already at or above this position the door will close. If the Man 1 Timer is greater than zero, the controller will delay the door for the duration of the timer. Upon expiration of the timer, the door will close to the Fully Closed position.</p>
<input type="checkbox"/> <b>Man 1 Part 2</b>	<p>Activation of this input will open the door to the Open Part 2 position if the door is not at this position. If the door is already at or above this position the door will close. If the Man 1 Timer is greater than zero, the controller will delay the door for the duration of the timer. Upon expiration of the timer, the door will close to the Fully Closed position.</p>

## SECTION 12 - MENUS - SINGLE PHASE CONTROLLER (continued.....)

RELAY OUTPUT FUNCTIONS	Description:
<input type="checkbox"/> No Function	Output is disabled.
<input type="checkbox"/> Door Moving	Output is active anytime the door is in motion.
<input type="checkbox"/> Door idle	Output is active anytime the door is not in motion
<input type="checkbox"/> Door Open	Output is active whenever the door is at the Fully Open.
<input type="checkbox"/> Door Closed	Output is active whenever the door is at the Fully Closed.
<input type="checkbox"/> Door Not Closed	Output is active whenever the door is above the Fully Closed position.
<input type="checkbox"/> Open Partial	Output is active whenever the door is at either the Open Part 1 or Open Part 2 position.
<input type="checkbox"/> Door Opening	Output is active whenever the door is moving in the open direction.
<input type="checkbox"/> Door Closing	Output is active whenever the door is moving in the closed direction.
<input type="checkbox"/> Delay To Close	Output is active whenever the Delay to Close Timer is greater than zero and the door is commanded to close.
<input type="checkbox"/> Delay to Open	Output is active when the Delay To Open Timer is greater than zero and the door is commanded to open. The input must remain activated until the Delay To Open Timer has expired, the output will be active during this time. Upon expiration of the timer the door opens and the output is deactivated.
<input type="checkbox"/> Auto 1 Active	Output is active whenever the Auto Close Timer is greater than zero.
<input type="checkbox"/> System Error	Output is active whenever an error is present.
<input type="checkbox"/> Pre-Warn	Output is active whenever the Auto Close or Manual 1 timers are active. The output remains active through the closing cycle until the door is Fully Closed.
<input type="checkbox"/> Open Alarm	Output is active if the Open Alarm Timer has expired.
<input type="checkbox"/> Open Light	Output is active whenever the door is in the Open State. This function should be used whenever door state signaling is required.
<input type="checkbox"/> Closed Light	Output is active whenever the door is in the Closed State. This function should be used whenever door state signaling is required.
<input type="checkbox"/> Part open Light	Output is active whenever the door is in the Open Part 1 or Open Part 2 State. This function should be used whenever door state signaling is required.

# SECTION 12 - MENUS - SINGLE PHASE CONTROLLER (continued....)



**Fig 12.4**

# SECTION 12 - MENUS - SINGLE PHASE CONTROLLER (continued....)

## PART 6 INFORMATION MENU

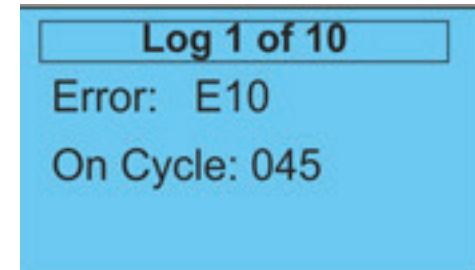
How to use the keypad to retrieve operation events, fault/shutdown messages, and system status (Also see Section 8—Troubleshooting)

- A. With the unit idle enter the System Status menu.
- B. Scroll through the list of choices until you reach the Fault Log menu and enter.
- C. Scroll through the list until you reach the information you're looking for.
- D. When finished exit the menus and return to the main screen.

**NOTE:** The items in the Fault Log are listed in reverse chronological order with number 1 being the most recent and the highest number being the oldest.

- If NO keys are pressed for 120 seconds, display will exit back to the main menu.
- Motion can occur and panel responds normally to inputs while in the System Status Menus.

## FAULT LOG



## PART 7 SETUP CHECK LIST

### ⚠ CAUTION

Check ALL items below to ensure that the Control Panel is installed and operating properly and entrapment protection is working properly. A door system that is not properly setup can cause death or serious injury.

#### CHECK

- The door operates using all installed control devices.
- The door runs to its full open and full closed positions.
- The Entrapment Protection Device(s) will reverse a closing door when actuated.
- The proper Actuator selections are made to activate timers.
- The Hand Chain/Crank interlock switch prevents motor/door movement when the hand chain is pulled or Crank handle inserted.

If the panel is in a location where public access is possible, install a means to limit access to the inside of the panel.

## SECTION 13 - TROUBLESHOOTING THE CONTROLLER

Refer to section 8 pg 40-45. Troubleshooting the single phase controller is the same as the three phase controller.



# SECTION 14 - SERVICE AND MAINTENANCE

## ▲ WARNING

Failure to perform specified service and maintenance may result in an unsafe condition, will void limited warranty, and may result in premature failure of the unit. Service and Maintenance are necessary to ensure safe operation of the ADV-X door.

### General Maintenance Interval Message

- Upon reaching 150,000 door cycles (300,000 & 450,000, etc.), the panel will display general maintenance needed.
- Contact your distributor to have required maintenance performed.
- Once service is completed, clear the service message by going into System Configuration ->System -> Clear Service.

### Sensing Edge & Photoeye systems

- Test sensing edge activation daily.
  - Place a solid object, higher than 12", on floor and close door. Sensing edge should reverse door direction on contact with object.
- Test Photoeye activation daily.
  - Obstruct the Photoeye beam with a solid object. Photoeye should reverse door direction.

### General Inspection

- Visually inspect wiring conduit and cables.
- Inspect fixtures such as: Bearings, conduit boxes, hood, gear box (for oil leakage), motor.
- Inspect safety labels, placement and condition.
- Lubricate guides with paste wax or silicone spray.

### Manual Operation of Door

- Inspect door alignment and level.
- Inspect curtain and endlocks for damage.
- Inspect guides, sensing edge and hood for damage.

### Mounting Bolt Tightness

- Check fasteners anchoring headplates and door guides to wall.

### Check Limit Position

- Verify the door stops at correct open position.
- Verify that door closes fully without excessive "stacking" of curtain in guides.
- Verify approach speeds provide for smooth starts and stops.

**Keep records of all service and maintenance.**

INSTALLATION DATE: \_\_\_\_\_ INSTALLER INITIAL: \_\_\_\_\_

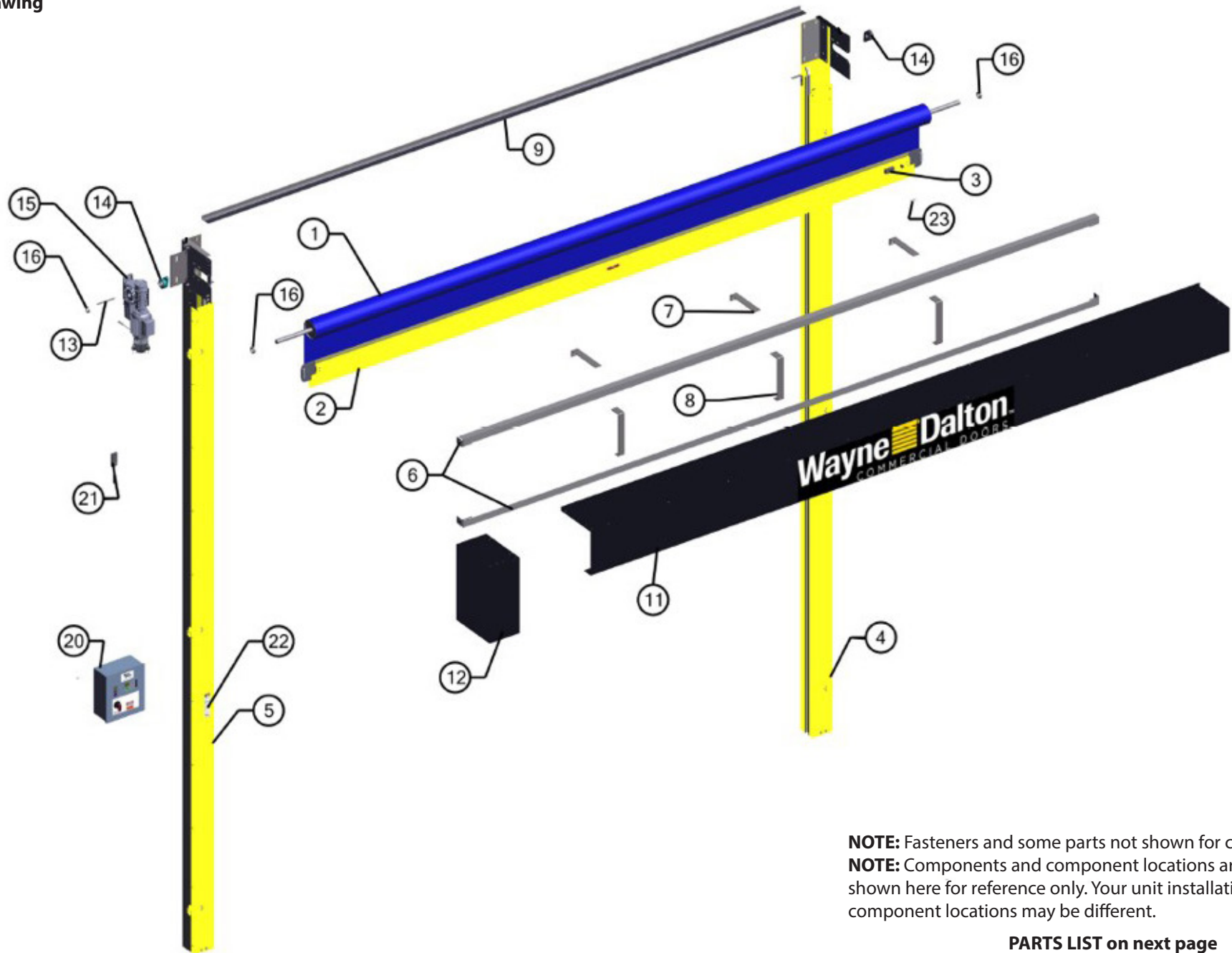
SERVICE ITEM	SERVICE INTERVAL (frequency)		
	EVERY DAY	EVERY 6 MOS. or 50,000 CYCLES	EVERY 12 MOS. or 100,000 CYCLES
General Inspection		•	
Limit Switch Chain Tension and Alignment		•	
Manual Operation of Door		•	
Sensing Edge & Photo Eye systems	•		
Mounting Bolt Tightness			•
Motor Brake Gap and Motor			•
Check Limit Position		•	
Check Emergency Brake Activation List		•	

**Table 9-A**

**Table 9-A provides a schedule of Service and Maintenance items.** To the right is a list of service and maintenance highlights.

# SECTION 15 - ILLUSTRATED PARTS BREAKDOWN

## Parts Drawing



**NOTE:** Fasteners and some parts not shown for clarity.  
**NOTE:** Components and component locations are shown here for reference only. Your unit installation and component locations may be different.

**PARTS LIST on next page**

# SECTION 15 - ILLUSTRATED PARTS BREAKDOWN (continued....)

**Table of Part Numbers**

BEFORE ORDERING PARTS LOCATE YOUR ORIGINAL DOOR NUMBER FOUND ON THE NAMEPLATE ATTACHED TO YOUR BOTTOM BAR							
ITEM	DESCRIPTION	PART NUMBER	BUILT TO ORDER	ITEM	DESCRIPTION	PART NUMBER	BUILT TO ORDER
1	COMPLETE CURTAIN ASSY.	INQUIRE	YES	13	KEY .375 X .375 X 9"	082090	NO
2	COMPLETE BOTTOM BAR ASSY.	INQUIRE	YES	14	FLANGE BEARING	600261	NO
3	SENSING EDGE CONDUIT BOX	500365	NO	15	MOTOR UNIT	INQUIRE	NO
4	RH GUIDE ASSEMBLY	INQUIRE	YES	16	SET COLLAR	604297-1150	NO
5	LH GUIDE ASSEMBLY	INQUIRE	YES	17	NOT USED	N/A	N/A
6	HEADER ASSEMBLY	822501	NO	18	NOT USED	N/A	N/A
7	HEADER BRACE WALL SIDE	822506	NO	19	NOT USED	N/A	N/A
8	HEADER BRACE FRONT SIDE	822505	NO	20	CONTROL PANEL	INQUIRE	NO
9	LINTEL ASSEMBLY	822503	YES	21	JUNCTION BOX	820603	NO
10	NOT USED	N/A	N/A	22	SAFETY LABEL	356994	NO
11	HOOD	822321	YES	23	SENSING EDGE WARNING LABEL	607873	NO
12	MOTOR COVER ASSY	822324	NO				



## ADV-X High Speed Fabric and Rubber Doors Limited Warranty

Wayne Dalton, a division of Overhead Door Corporation, ("Seller") warrants to the original purchaser of the high speed fabric and rubber door models 881 ADV-X, 882 ADV-X, 883 ADV-X, 884 ADV-X, and 885 ADV-X ("Product"), subject to all of the terms and conditions hereof, that the Product thereof will be free from defects in materials and workmanship under normal use for the following periods, measured from the date of installation.:

- **Seller warrants all mechanical door system components and the control panel hardware for a period of 60 MONTHS**

Seller's obligation under this warranty is specifically limited to repairing or replacing, at its option, any part which is determined by Seller to be defective during the applicable warranty period. Repair or replacement labor for any defective Product component is excluded and will be the responsibility of the purchaser.

This warranty is made to the original purchaser of the Product only, and is not transferable or assignable. This warranty does not apply to any unauthorized alteration or repair of the Product, or to any Product or component which has been damaged or deteriorated due to misuse (including used of interior rated products in exterior applications), neglect, accident, failure to provide necessary maintenance, normal wear and tear, or acts of God or any other cause beyond the reasonable control of Seller. This warranty does not cover replacement batteries or apply to any damage or deterioration caused by door fabric and/or rubber curtain rubbing together as the door rolls up upon itself, puncture, or caused by exposure to salt water, chemical fumes or other corrosive or aggressive environments, whether naturally occurring or man-made, including, but not limited to, environments with a high degree of humidity, sand, dirt or grease.

**THIS WARRANTY IS EXCLUSIVE AND IN LIEU OF ANY OTHER WARRANTIES, EITHER EXPRESS OR IMPLIED, INCLUDING BUT NOT LIMITED TO ANY IMPLIED WARRANTY OF MERCHANTABILITY OR FITNESS FOR A PARTICULAR PURPOSE.**

**IN NO EVENT SHALL SELLER BE RESPONSIBLE FOR, OR LIABLE TO ANYONE FOR, SPECIAL, INDIRECT, COLLATERAL, PUNITIVE, INCIDENTAL OR CONSEQUENTIAL DAMAGES, even if Seller has been advised of the possibility of such damages. Such excluded damages include, but are not limited to, loss of goodwill, loss of profits, loss of use, cost of any substitute product, interruption of business, or other similar indirect financial loss.**

Claims under this warranty must be made promptly after discovery, within the applicable warranty period, and in writing to the Seller or to the authorized distributor or installer whose name and address appear below. The purchaser must allow Seller a reasonable opportunity to inspect any Product claimed to be defective prior to removal or any alteration of its condition. Proof of the purchase and/or installation date, and identification as the original purchaser, may be required.

DOOR MODEL: \_\_\_\_\_

ORIGINAL PURCHASER: \_\_\_\_\_

INSTALLATION ADDRESS: \_\_\_\_\_

SELLER: \_\_\_\_\_

SELLER'S ADDRESS: \_\_\_\_\_

FACILITY ORDER #: \_\_\_\_\_

DATE OF INSTALLATION: \_\_\_\_\_

SIGNATURE OF SELLER: \_\_\_\_\_