



# Model 600 ADV Advanced Rolling Grille System



## Installation Instructions

This installation manual provides the trained grille technician information required to install, troubleshoot and maintain a Model 600 ADV Advanced Rolling Grille System.

**READ COMPLETE INSTRUCTIONS BEFORE INSTALLING Grille.**

Some installation tasks listed in this document are found in other documents.

Please refer to the appropriate document(s) as directed;

308577 Hilti Kwik Bolt  
Installation Found on  
[odcexchange.com](http://odcexchange.com)

**Installation, repairs, and adjustments must be made by a trained grille system technician using proper tools and instructions.**

**INSTALLER: Leave this manual with the end user!**

# Table of Contents

TABLE OF CONTENTS		
SECTION	DESCRIPTION	PAGE
1	<b>SAFETY INFORMATION</b>	3-4
2	<b>HOW TO USE THIS MANUAL</b>	5
3	<b>GENERAL INFORMATION</b>	6-8
	COMPONENT IDENTIFICATION DRAWING	6
	INSTALLATION DATA SHEET	8
4	<b>INSTALLATION</b>	9-23
5	<b>WIRING</b>	24-34
	CONTROL PANEL WIRING	25-28
	JUNCTION BOX WIRING	29
	PHOTOEYE WIRING	30-31
	ENCODER WIRING	32
	OPTIONS WIRING	33-34
6	<b>INITIAL STARTUP PROCEDURE</b>	35-44
7	<b>SPECIAL DOOR SYSTEM FEATURES</b>	45
8	<b>TROUBLESHOOTING</b>	46-51
9	<b>SERVICE AND MAINTENANCE</b>	52
10	<b>ILLUSTRATED PARTS BREAKDOWN</b>	53-54
END	<b>WARRANTY</b>	55

# Section 1

## Safety Information

### ⚠ WARNING

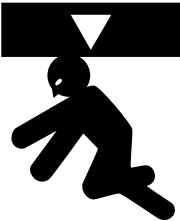

Advanced Performance service grilles are large, heavy objects that move with the help of electric motors. Since moving objects and electric motors can cause injuries, your safety and the safety of others depends on you reading the information in this manual. If you have any questions or do not understand the information presented, you should consult a licensed professional.

In this section and those that follow, the words "**DANGER**", "**WARNING**", and "**CAUTION**" are used to stress important safety information. The word:

- ⚠ **DANGER** indicates an imminently hazardous situation which, if not avoided, will result in death or serious injury.
- ⚠ **WARNING** indicates a potentially hazardous situation which, if not avoided, could result in death or serious injury.
- ⚠ **CAUTION** indicates a potentially hazardous situation which, if not avoided, may result in injury or property damage.

The word **NOTE** is used to indicate important steps to be followed or important considerations.

1. Read manual and warnings carefully.
2. Keep the grille in good working condition.
3. This grille is equipped with a sensing edge, check sensing edge operations daily. Make any necessary repairs to keep it functional.
4. All models are equipped with an overcurrent device. This must be manually reset following an overcurrent condition.
5. Keep instructions in a prominent location near the Control Panel.

POTENTIAL HAZARD	EFFECT	PREVENTION
 <p>MOVING Grille</p>	<p>⚠ <b>WARNING</b> Can Cause Serious Injury or Death</p>	<p><b>Do NOT</b> operate unless the grilleway is in sight and free of obstructions. Keep people clear of opening while grille is moving.</p> <p><b>Do NOT</b> change control to momentary contact unless an external reversing means is installed.</p> <p><b>Do NOT</b> operate a grille that jamps.</p>
 <p>ELECTRICAL SHOCK</p>	<p>⚠ <b>WARNING</b> Can Cause Serious Injury or Death</p>	<p>Turn <b>OFF</b> electrical power before removing Control Panel or motor cover.</p> <p>When replacing Control Panel cover make sure wires are <b>NOT</b> pinched or near moving parts.</p> <p>Operator must be electrically grounded.</p>

# Safety Instructions

## Electrical Power Requirements for all Advanced Performance Service Grille Models

All Advanced Performance Service Grille models are available in 220/240V AC 1-phase or 230V AC and 460V AC 3-phase as input voltage options. 575 VAC input power is available with the use of a three phase, 575 VAC/460 VAC step-down transformer for all Advanced Performance Service Grille models. **YOUR LOCAL CODES MAY REQUIRE THAT THE INCOMING POWER TO YOUR MODEL 600 ADV ADVANCED ROLLING GRILLE SYSTEM HAVE A LOCK-OUT / TAG-OUT EQUIPPED FUSED DISCONNECT SWITCH (TO BE FURNISHED BY OTHERS) WITHIN EYESIGHT OF THE GRILLE'S CONTROL PANEL.** Incoming power wiring must meet all NEC and local building codes, plus be properly sized for the control panel's amperage rating on the nameplate. To reduce the risk of electric shock, the chassis of the control panel must be properly grounded.

### CAUTION

*The Model 600 ADV Advanced Rolling Grille System must be supplied by a properly grounded voltage supply, e.g. 220/240 VAC 1-phase or 208/230/460/575 VAC 3-phase. Floating (Open Delta) ungrounded voltage supply sources should not be used. For 480 VAC, 240 VAC or 120 VAC unbalanced Delta systems should **NOT** be used. Voltage unbalance is a common occurrence on Delta supply systems, which power both single phase and three phase loads, which can lead to unequal voltages on each phase leg. Voltage unbalance can cause deterioration of motor performance, such as loss of torque, overheating, decreases in the winding insulation life, and can cause motor starter contacts on the control panel to permanently "weld" closed. Voltage unbalance can be caused by inadequate conductor sizing, Delta transformer sizing, excessive single-phase loads, poor grounding, or intermittent high resistance faults which may cause destructive over-voltages to occur.*

***Wayne Dalton's warranty WILL NOT cover damage caused by failure of the motor, control panel or other electrical components due to the use of an inadequately grounded system.***

## Section 2

# How to Use This Manual

The sections of this Installation Manual provide the information required to install, troubleshoot and maintain the *Model 676 Advanced Performance Service Grille System*.

- **Section 1 - Safety Information**

**Safety Information and Instructions.** Important information related to safety terminology used throughout this manual. Safety related instructions must be followed at all times while performing any steps/tasks/instructions detailed in this manual.

- **Section 2 - How to Use This Manual**

Provides an overview of component information and how to use this manual.

- **Section 3 - General Information**

Details pre-installation issues that are recommended to be considered and/or resolved prior to beginning this grille system installation.

### **WARNING**

Failure to correctly perform all steps in Sections 4–6 can result in serious injury or death. Each section must be followed in step by step order to complete a successful installation.

- **Section 4 - Installation**

Provides step by step physical installation instructions for this product.

- **Section 5 - Wiring**

Provides step by step wiring instructions for this product.

- **Section 6 - Grille System Set Up Procedures**

Provides step by step control set up and programming instructions for this product.

- **Section 7 - Special Grille System Features**

Optional Exterior Hood Installation.

- **Section 8 - Troubleshooting**

Details important troubleshooting information for typical installation, operator fault codes for troubleshooting and service, and normal operation codes that may occur.

- **Section 9 - Service and Maintenance**

Provides related information on service and maintenance items.

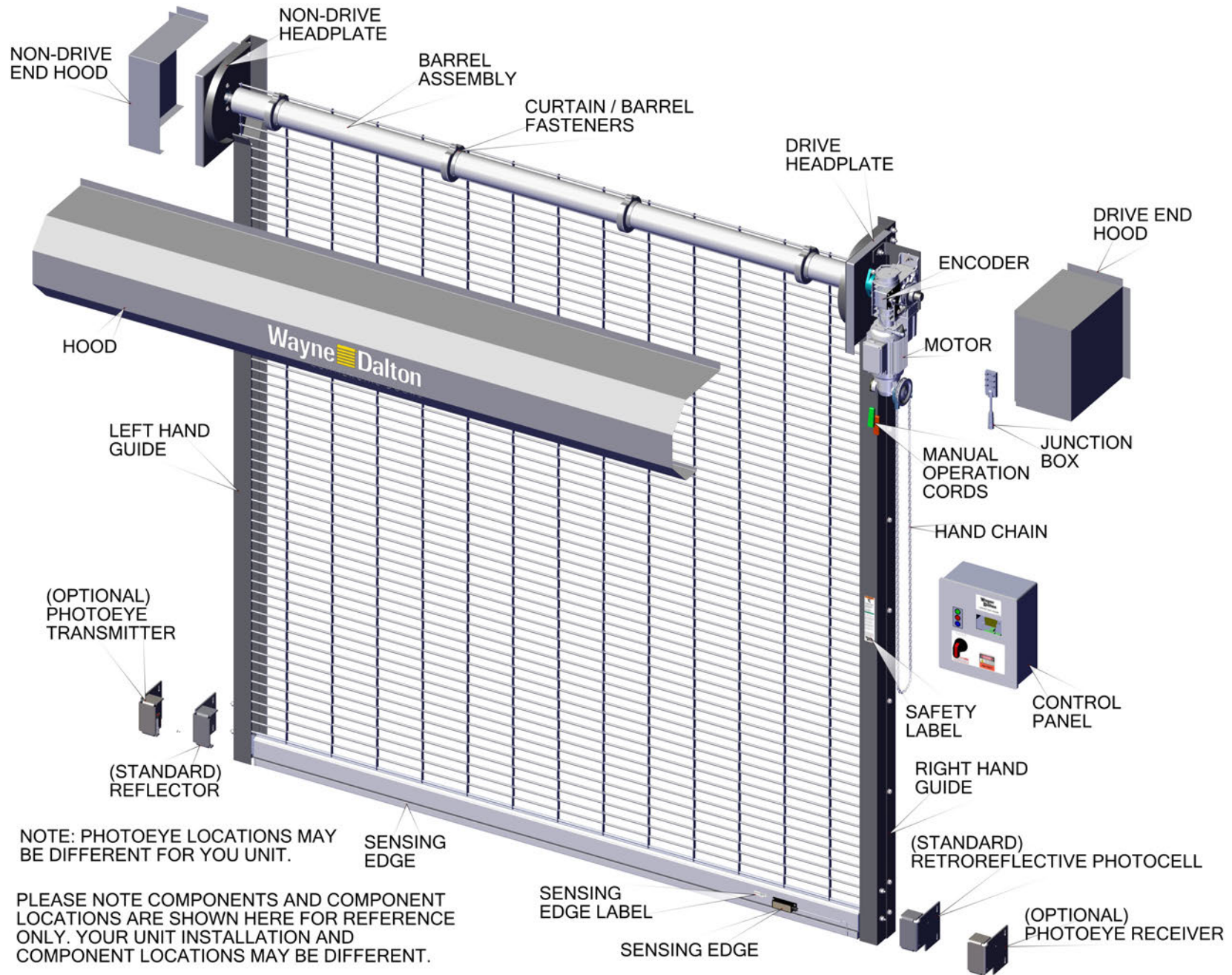
- **Section 10 - Illustrated Parts Breakdown**

Provides an illustrated parts breakdown for this product, including parts identification.

- **Section 11 - Return Goods Policy**

Provides returned goods policy information.

# Component Identification Drawing



NOTE: PHOTOEYE LOCATIONS MAY BE DIFFERENT FOR YOUR UNIT.

PLEASE NOTE COMPONENTS AND COMPONENT LOCATIONS ARE SHOWN HERE FOR REFERENCE ONLY. YOUR UNIT INSTALLATION AND COMPONENT LOCATIONS MAY BE DIFFERENT.

# Section 3

## General Information

### Job Site Issues/Considerations

The following list of items should be considered prior to installing an Advanced Performance Grille.

- Verify the opening measurements, head room, and side room required for this installation.
- Type of grille jamb.
- Availability of a power supply, which side of grille it is on and what the line voltage is.
- Grille system mounting environment. Items to consider include operator location, dampness of location, dustiness of the location and corrosiveness of the location.
- Grille activation needs and requirements. Examples include 3 button control stations, 1 button control stations, radio controls, pull cords, loop detectors, photoeyes, key switches, motion detectors, etc.
- Accessory equipment needs and requirements. Examples include sirens, warning lights, etc.

### Entrapment Protection

Photoeyes and sensing edges are required for all electrically operated Advanced Performance grilles. Both photoeyes and sensing edge are standard with these models. Do **NOT** disable them.

### Grille Specifications

GRILLE MODEL NUMBER:	676
OPENING WIDTH:	
OPENING HEIGHT:	
MOTOR MOUNTING: (check one)	<input type="checkbox"/> INTERIOR or <input type="checkbox"/> EXTERIOR <input type="checkbox"/> LEFT HAND or <input type="checkbox"/> RIGHT HAND
CURTAIN COLOR:	
OPERATOR: HP _____	RATIO _____
OPERATOR VOLTAGE:	
"S" DIMENSION _____	"G" DIMENSION _____
HEADROOM REQUIREMENT:	
SIDE ROOM: DRIVE _____	NON-DRIVE: _____
GUIDE GAP _____	GUIDE TYPE _____
CURTAIN WEIGHT: _____	



### Installation Data

NAME PLATE SERIAL NUMBER:
JOB NAME:
DISTRIBUTOR:

**NOTE:** The ID plate is located on the bottom bar.

# Installation Data Sheet

## 1. INSTALLATION DATA SHEET

- A. Your "INSTALLATION DATA SHEET" looks like **Fig. 3-A**. It is found **inside** the grille hardware box. You will need to refer to the data on this sheet during installation. Record the pertinent data on page 7 of this manual as a backup.
- B. Verify that the "Factory Order Number" on the grille components matches the one shown on the INSTALLATION DATA SHEET.

## 2. PRE-INSTALLATION CHECK LIST

- Ensure the grille installation can be accomplished before proceeding.
- Check that the wall opening, **Fig. 3-B**, matches the Opening Width and Height shown on the Installation Data Sheet.
  - Check that the sill is level and plumb.
  - Verify the guides you received are suitable for the jambs. Compare the guide type on the Installation Data Sheet with **Fig. 3-C**.

69415 Parent. 75007192 WO 75007187 \*\* OVERHEAD DOOR CORPORATION \*\*\*\*\* Page . 9 Date . 6/25/14  
 W.C./Parent. 75007192 WO 75007187 \*\* OVERHEAD DOOR CORPORATION \*\*\*\*\*  
 \*\*\*\*\*  
 Related SO . 75132101 SF 1.008 Plant. . . . 17  
 Lot # . . . . .  
 Item Number.HW621 \*\*\*\*\*  
 Customer . . . 17 OHD CORP - PENNSYLVANIA (R/S) FACILITY Qty. . . . 1.00 Start Dt . 06/25/14 Req D. 06/25/14  
 Status . . . 12 Pcy. . . . . Job. . . . . Drawing #. NONE  
 Type . . . . . P.O. # . . . . .  
 WALL OPENING : 12 ' - 0 0/8 WIDE X 10 ' - 0 0/8 HIGH PRDCT: D621 SLAT TYPE : F265 GAUGE : 22 WINDLOAD : 20  
 GUIDE TYPE : ANGLE GUIDE ENTRY TYPE : DOUBLE FLARE GD. CONFIGURATION: E DRIVE SIDE : RIGHT DRIVE NO. : 1 HP 1:60 RATIO  
 BOTTOM BAR TYPE: DOUBLE ANGLE BEAR MTL.: PLAIN STL. BEAR FINISH : FDR CT RAL7046  
 DOOR MOUNT : FACE OF WALL WALL MOUNT : INT. WALL OPERATION : ELECTRIC-BY OHD BBAR WEATHERSTRIP : NO  
 \*\*\* DOOR SERIES : D621 \*\*\* GROUPING # : ABBV/COLOR : BWS  
 \*\*\*\*\* HARDWARE DETAILS \*\*\*\*\*

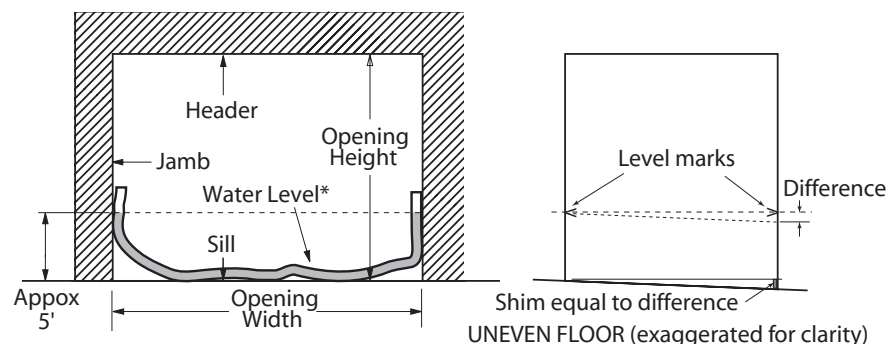
DOOR SERIES : D621		DOOR INSTALLATION DATA:			
WALL OPENING WIDTH	WALL OPENING HEIGHT	GUIDE TYPE	S REFERENCE	MAND DRIVE	OPERATION TYPE
12 ' - 0 0/8	10 ' - 0 0/8	ANGLE	151 1/2	RIGHT	ELECTRIC-BY OHD
WORKING TURNS	NET TURNS	DRIVE NO.	CURTAIN/BOTTOM BAR W.	PIPE ASSEMBLY WEIGHT	
3.9		1 HP 1:60 RATIO	483.93 LBS	91.86 LBS	
GUIDE GAP	GUIDE CONFIG	MOUNTING	ACTUATION OPTIONS		
15/16	E	INT. WALL			

\*\*\*\*\*  
**Related SO . 75132101 SF 1.008**  
 HARDWARE, 621 SERIES, RAPID SLAT

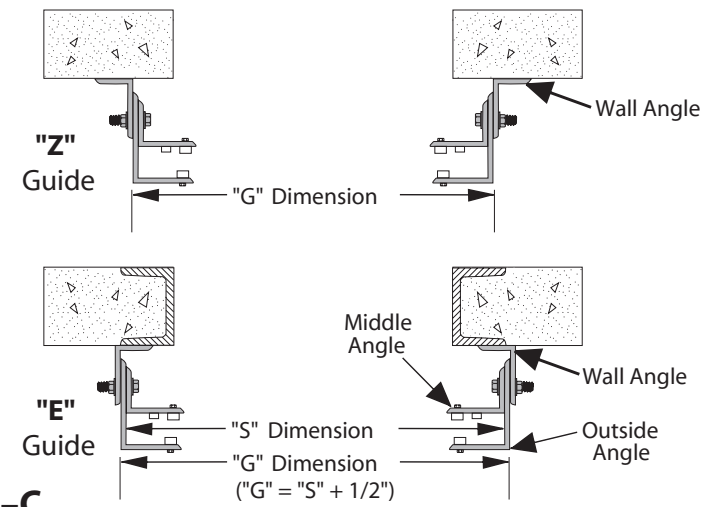
**Factory Order Number**  
 (Number shown for reference only)

**S REFERENCE**  
 151 1/2

**"S" Reference**  
 (Number shown for reference only)



**Fig 3-B** \* Laser level may also be used.



**Fig 3-C**



# Section 4

## Installation

### 1. INSTALL GUIDE WALL ANGLES

**NOTE:** It is only necessary to disassemble the guides for screw attachment of "E" type guides. Welded "E" assemblies and all "Z" assemblies may be installed as assembled from the factory.

- A. Remove the middle angles and outside angles from the guide wall angles. (Perform this for "E" non-welded guides only.)
- B. Mount guide wall angles to achieve the "S" dimension (on the Installation Data Sheet) plus 1/2" as shown in the illustration on the previous page **Fig. 3-C**. (The extra 1/2" allows for the thickness of the outside angle.)
  - The "G" ("S" + 1/2") dimension must be held within 1/8" over the entire height of the wall angle.
  - The guides must be on a level plane and plumb.
    - Place shims under the wall angle on the tall side of the opening if necessary to put them on level, **Fig. 3-B**.
    - Check plumb with a level or plumb bob.

### 2. MOUNTING METHODS

The following instructions use the Z-Guide positioning for the wall angles, use the Z-Guide or E-Guide positioning best suited for your site.

#### Masonry Jambs

- Hold Z-Guide wall angle against the wall and drill mounting holes through the slots using drill size shown in **Table 4-A**. Install jamb fasteners (**Table 4-A**) on one wall angle. Install second wall angle at "G" distance, refer to **Fig. 3-C** on the previous page. Check for level and plumb. Use spacers between Guide and wall as needed for plumb.

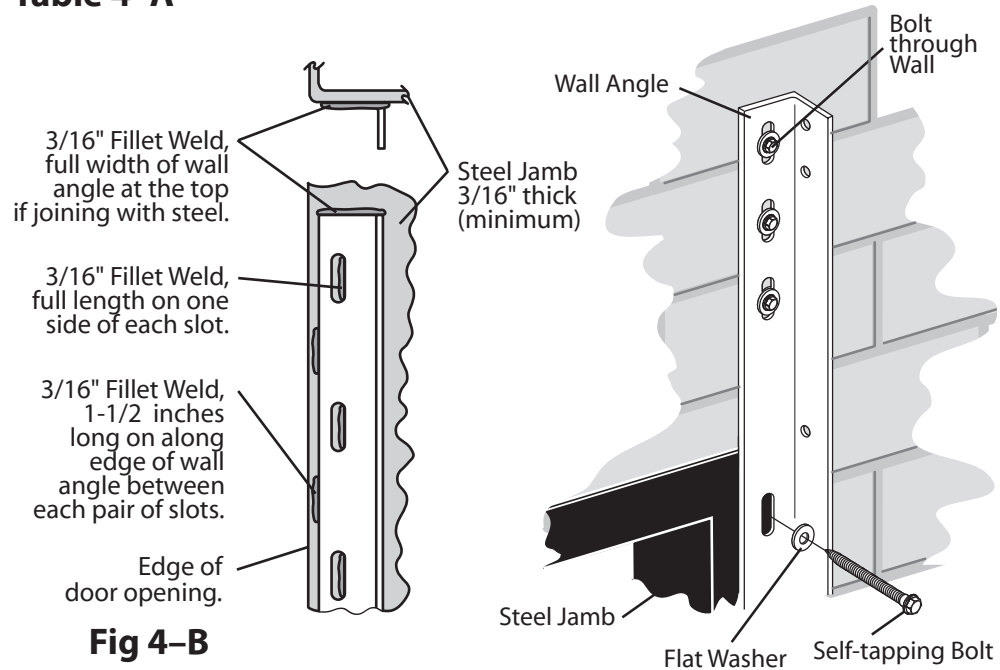
#### Steel Jambs

Steel jambs (welded or screwed) use "E" guides, all others use "Z".

- **SCREW ATTACHMENT OPTION**
  - Hold E-Guide wall angle against the jamb and drill holes through the slots using drill size shown in **Table 4-A**. Install all jamb fasteners (**Table 4-A**) on one wall angle, then install second wall angle at "G" ("S" + 1/2") (**Fig. 3-C**) distance. Check for level and plumb.
- **WELD ATTACHMENT OPTION**
  - Hold E-Guide wall angle against the jamb and tack weld in place. Install second wall angle at "G" ("S" + 1/2") (**Fig. 3-C**) distance. Check for level and plumb. Apply welds as shown in **Fig. 4-B**, using welding electrodes E6010, E6011 or E7014.

JAMB	FASTENER	DRILL SIZE	JAMB FASTENER SPECIFICATIONS
Steel	1/2" self-tapping screw	27/64" diameter	Steel jambs must be minimum 3/16" thick
Concrete	1/2" wedge anchor	1/2" diameter	Drill hole at least 4" from jamb corner per OHD Installation Instruction 308577 available on <a href="http://odcexchange.com">odcexchange.com</a> .
Filled block	1/2" wedge anchor	1/2" diameter	Drill hole at least 4" from jamb corner per OHD Installation Instruction 308577 available on <a href="http://odcexchange.com">odcexchange.com</a> .
Wood	1/2" lag screw	3/8" diameter	Drill hole 3" deep
Unfilled block	1/2" thru bolt	9/16" diameter	Install 3" O.D. steel washer on opposite side of wall.

**Table 4-A**



**NOTE:** When the wall angle extends above the steel of the jamb or header, use washers, spacers or shims to fill the gap between the masonry portion of the wall and the wall angle. Use through bolts to fasten the wall angle in the area above steel, **Fig. 4-C**.

## Installation (continued)

### 3. IDENTIFY HEADPLATE BRACKETS, Fig. 4-D

Right hand drive is shown (left hand drive opposite).

### 4. IDENTIFY DRIVE END OF BARREL ASSEMBLY, Fig. 4-E

Right hand drive is shown (left hand drive opposite). The **drive end** of barrel assembly typically is longer and is keyed. Fig. 4-E

### 5. ASSEMBLE BARREL AND HEADPLATE BRACKETS, Fig. 4-G

- A. Slide the drive headplate bracket and bearing onto drive end of the barrel shaft (longer shaft).
- B. Slide the non-drive headplate bracket and bearing onto the non-drive end of the barrel shaft (shorter shaft).
- B. Slide one set collar onto the drive end and another set collar onto the non-drive end of the barrel assembly.
- E. Lightly tighten the set screws on the set collars.
- G. The distance between the outside of the headplate brackets should be less than the "S" dimension, Fig. 3-C Page 8.
- H. Do **NOT** tighten bearing or set collar set screws at this time.

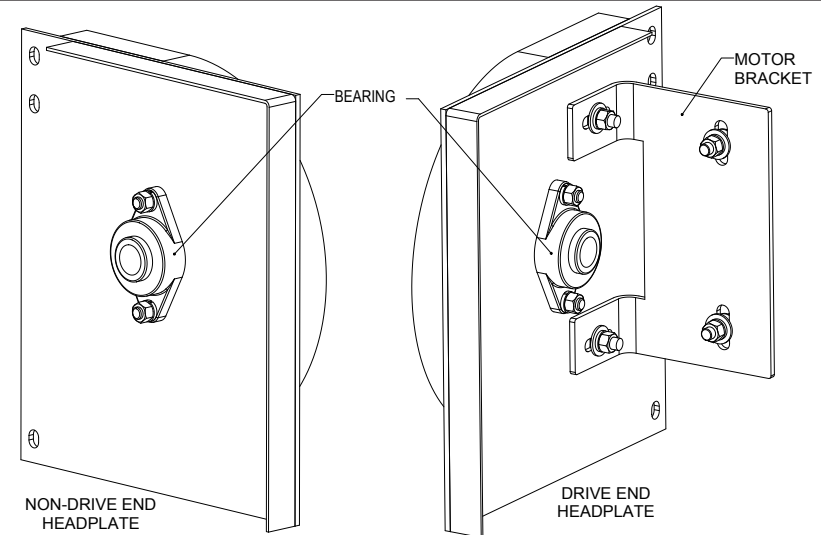


Fig 4-D

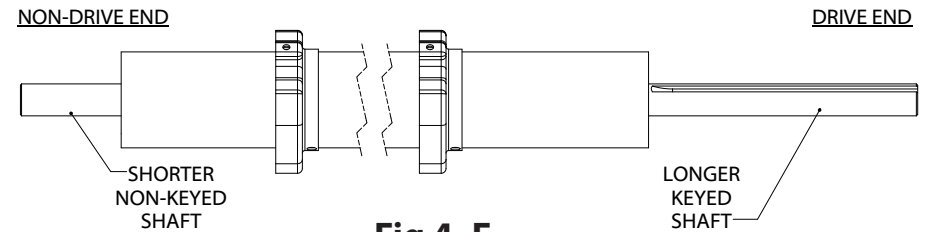


Fig 4-E

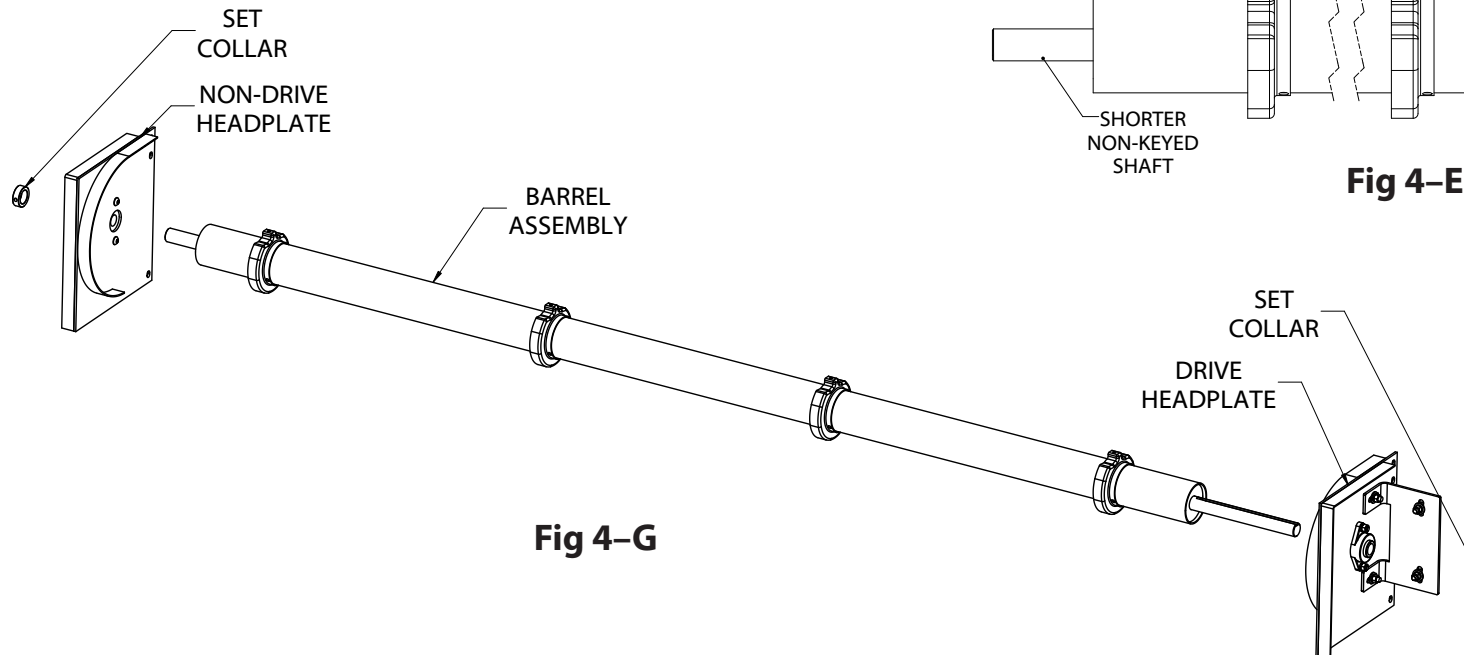


Fig 4-G

## Installation (continued)

### CAUTION

Use proper lifting equipment and correct lifting procedures to avoid injury.

#### 7. MOUNT BRACKETS AND BARREL ASSEMBLY, Fig. 4-F

- A. Headplate brackets must be square to the wall and parallel.
- B. Use hex bolts, nuts and washers (provided) to fasten headplate brackets to the inside of the wall angles. Use washers under both the bolt head and nut.
- C. Bolt heads must be on the inside of the headplate brackets.
- D. Use a level to **make sure the barrel is level**.

### CAUTION

A level barrel is crucial to the correct operation of the curtain. If the barrel is NOT level, the curtain will begin to “telescope” towards the low end and may damage the curtain.

- E. Position the barrel assembly such that the curtain, mounted on the barrel, will be centered between the headplates, **Fig. 4-H**.
- F. Tighten bracket bearing set screws on both headplates to prevent barrel from sliding side to side.
- G. Slide set collars against headplate bearings and tighten set screw on the set collars.

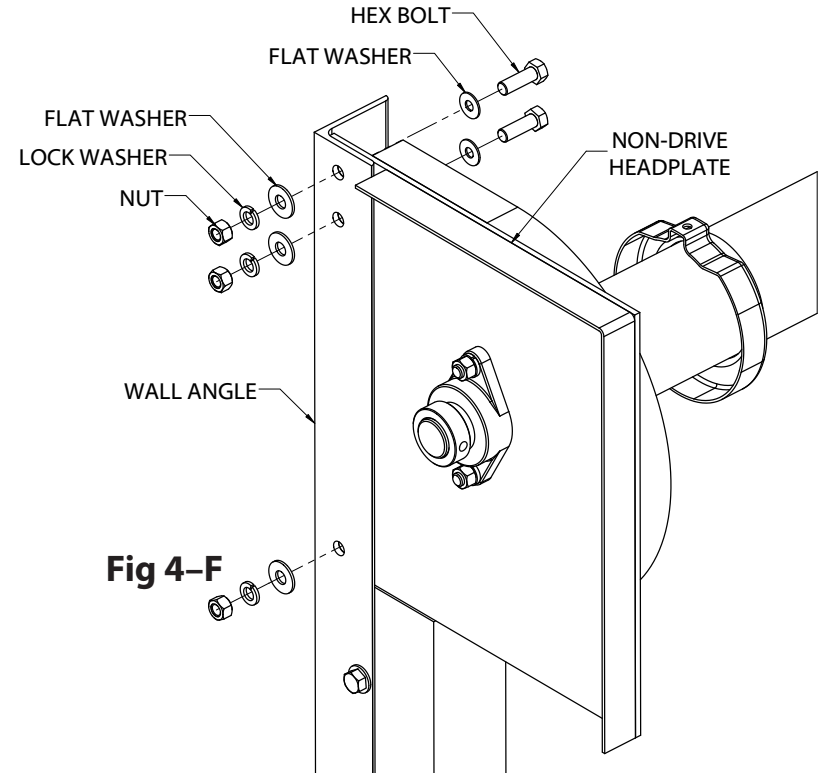


Fig 4-F

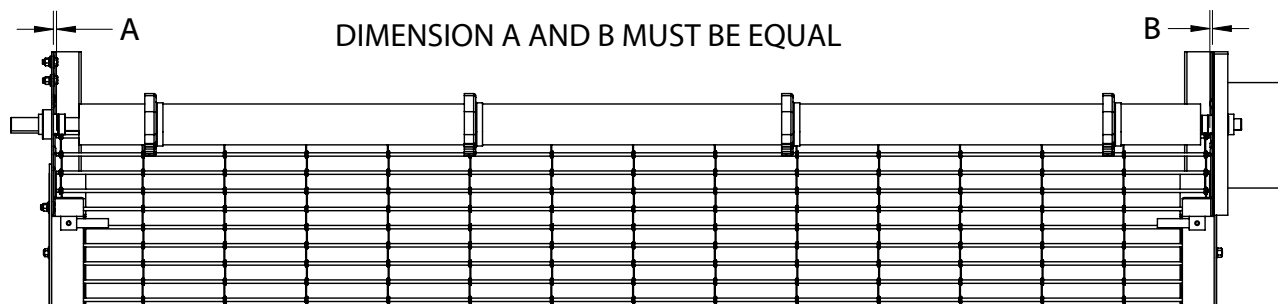


FIG 4-H

## Installation (continued)

### 8. INSTALL MOTOR

- A. Remove motor mounting hardware from the motor bracket **FIG4-I(a)**.
- B. Loosen (but do not remove) the hardware holding the motor bracket to the headplate.
- C. Apply lubricant (*anti-seize compound (provided)*) to inside of gearmotor bearing.
- D. Slide the motor onto the shaft and reinstall the mounting hardware. **FIG 4-I(b)**
- E. Tighten the motor bracket hardware loosened in a previous step.
- F. Manually turn the shaft as needed to align the keyway of the motor with the keyway of the shaft. Install the key.
- G. Install the sprocket and chain as shown in **Fig. 4-I(b)**.
- H. Be sure the sprocket on the encoder and the larger sprocket are in line with each other. Use a straight edge to check.
- I. Tighten the set screw on the sprocket.

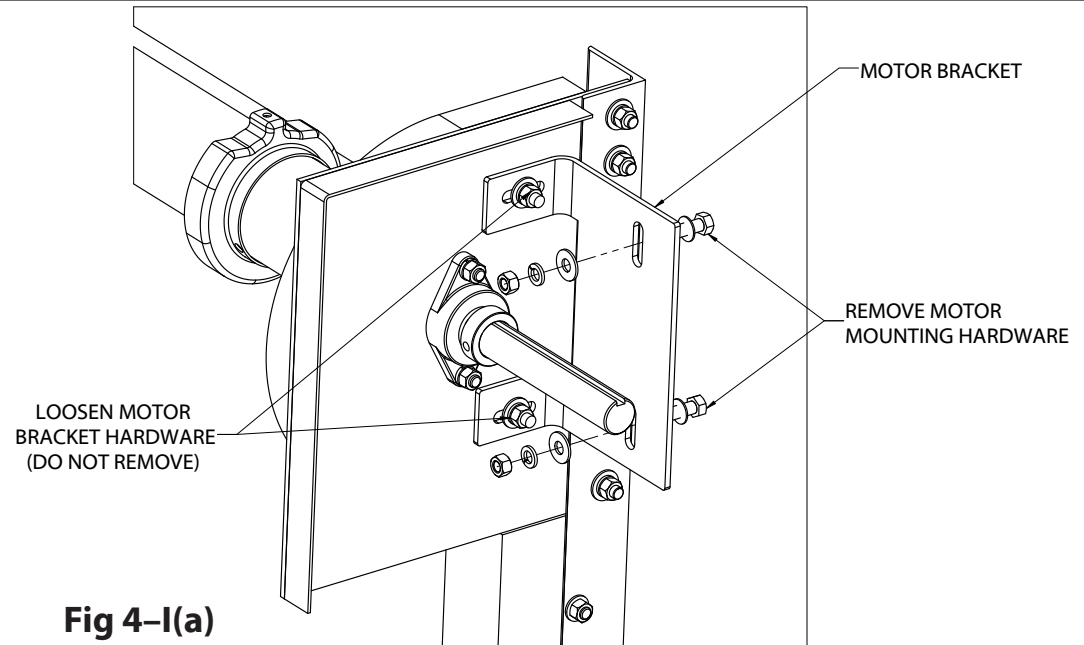


Fig 4-I(a)

**CAUTION**

The chain sprockets must be directly in line with each other to prevent sprocket wear and encoder damage.

**WARNING**

Do NOT connect power at this time. Power must be routed through the controller that will be mounted in a later step. Connecting Mains power directly to the motor will result in uncontrolled operation with possible serious injury or death.

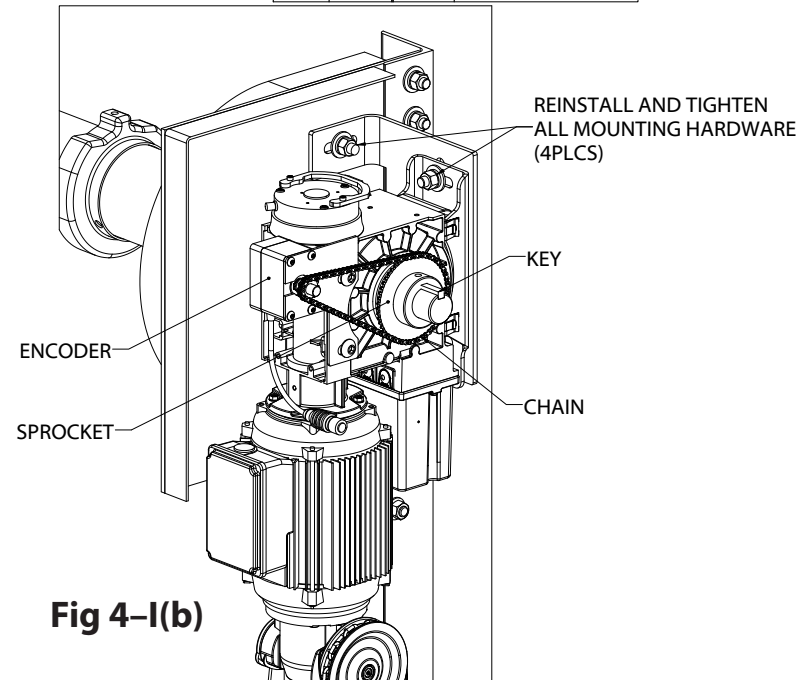


Fig 4-I(b)

## Installation *(continued)*

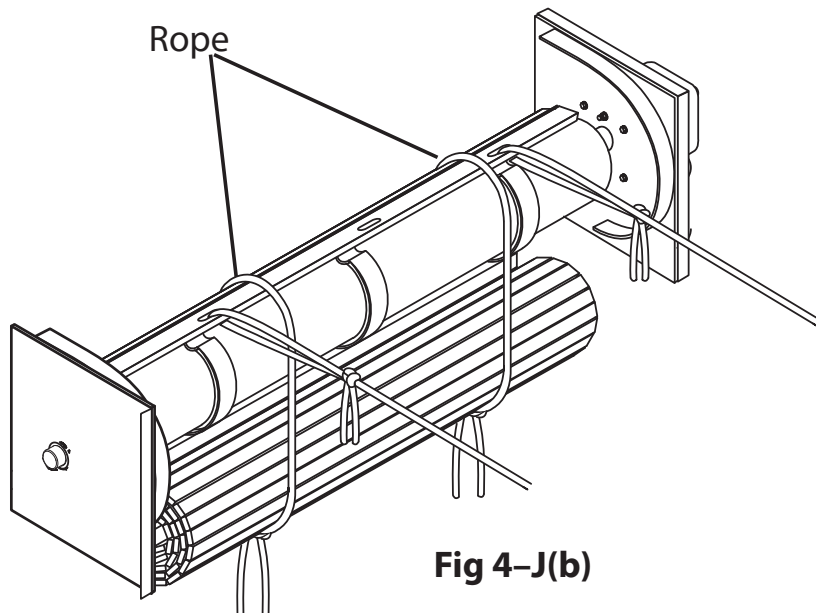
### 9. INSTALL CURTAIN ONTO BARREL

**NOTE:** If guide angles are already installed, cover the bell mouth opening of the guide angles to protect the curtain from being scratched or damaged during these steps.

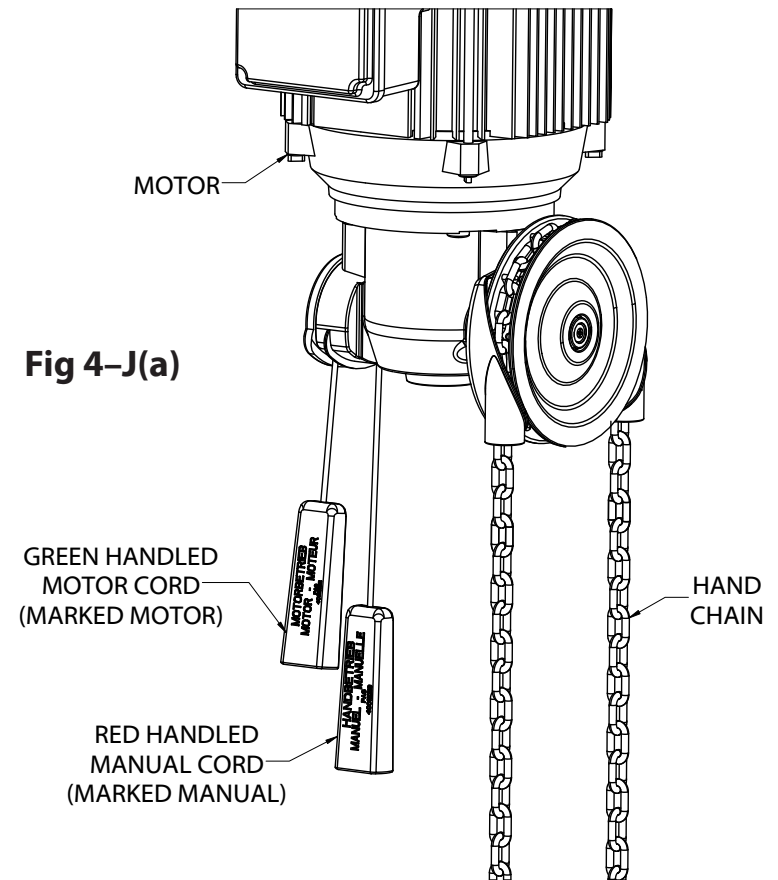
- A. Pull the red manual operation cord on the motor (**FIG 4-J(a)**) and use the hand chain to rotate the barrel assembly so that the bolt holes or studs on the barrel rings are facing up. Different barrel assembly lengths will have more or less rings/studs, **Fig. 4-K(a)** and **Fig. 4-K(b)** on page 14.
- B. Suspend the curtain below the barrel on two or three slings or ropes rated for the weight of the curtain, **Fig. 4-J(b)**. (Refer to your Installation Data Sheet.)

### **⚠ WARNING**

Ensure the slings/ropes are securely fastened as they will temporarily support the weight of the curtain. Improper use of slings /ropes could result in the unsecured curtain falling which could cause severe injury or death.



**Fig 4-J(b)**



**Fig 4-J(a)**

## Installation (continued)

C. Center the curtain between the headplate brackets and pull the top slat up and over the back side of the barrel.

- On small grilles, the curtain can be rotated by hand.
- On large grilles attach the top slat to two slings/ropes and rotate the slings/ropes to bring the top slat into position.

If the barrel has rings,

- Pull the curtain up and hold top slat against the rings, **Fig. 4-K(a)**.
- Align the slots in the top slat with the holes in the rings.
- Fasten the curtain to the rings with 3/8"-16 x 5/8" Torx head screw and washers provided.

### CAUTION

Take care to prevent stripping threads. Stripping could result in the need to replace the barrel rings.

If the barrel has studs,

- Pull the curtain up and hook the slots in the top slat over the studs.
- Fasten at each stud with a 1/4"-20 x 3/4" round head screw, flat washer, and two clamp washers (provided), **Fig. 4-K(b)**.

D. Coil the curtain completely onto the barrel using the hand chain.

E. Remove bottom slat end lock and attach Sensing edge.

F. Replace bottom slat end lock.

G. Feed safety edge and curtain into bellmouth of guide.

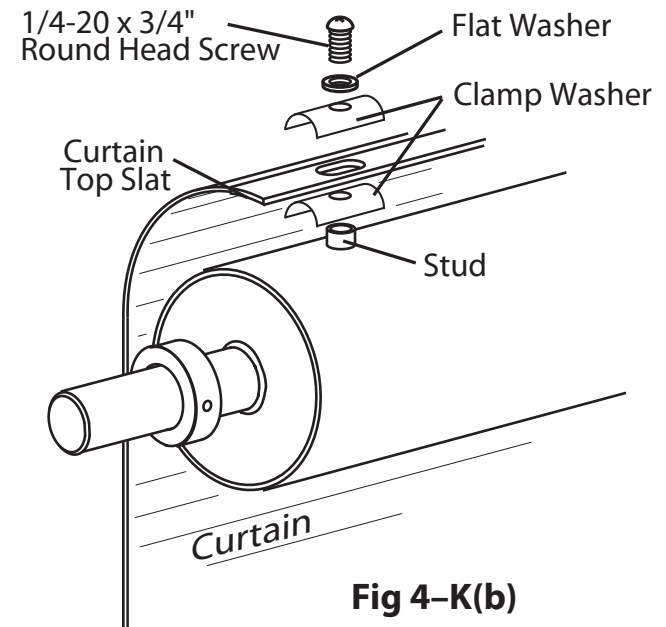
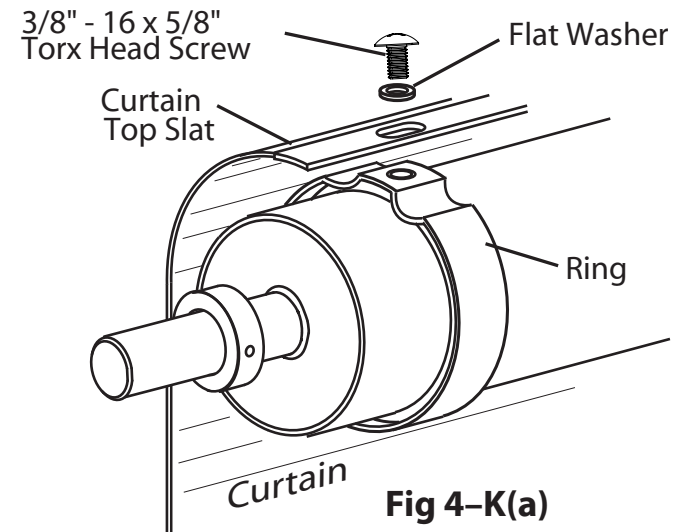
H. Using the hand chain, lower curtain into guides.

I. Install provided bottom bar stops.

### WARNING

Do NOT remove the slings or ropes at this time.

**NOTE:** In figures 4-K(a) & K(b) Headplate and bearing not shown for clarity.



## Installation (continued)

If you have welded "E" assemblies or "Z" assemblies factory assembled and have already installed them in a previous step, skip Step 10.

### 10. INSTALL GUIDE ANGLES

Bolt the middle angles and outer angles to the wall angles as shown in **Fig. 4-L**. (Wall angles may be mounted inside or outside based on installation requirements, **Fig. 4-M**.)

- The "Guide Gap" **MUST** be set to the value given on the Installation Data Sheet. Refer also to Grille Specifications on page 7.

### 11. RELEASE THE CURTAIN

- A. Pull the green motor cord to re-engage the motor and brake.
- B. Remove the slings or ropes. The curtain is now held in place by the motor brake.

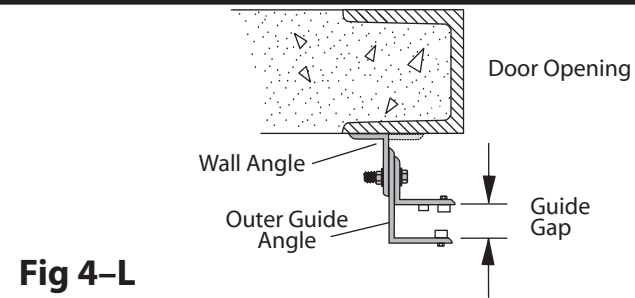


Fig 4-L

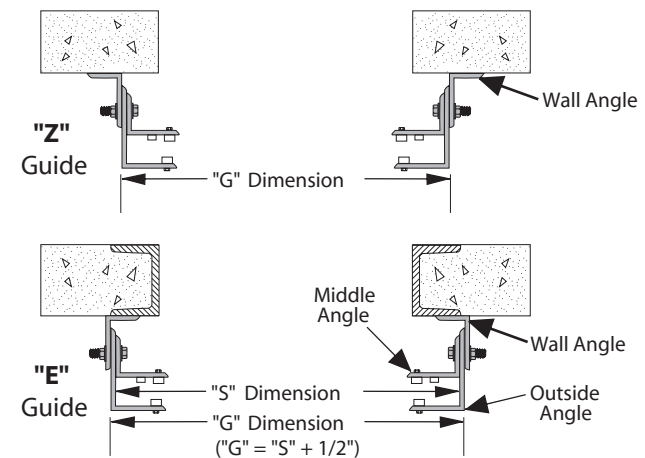


Fig 4-M

## Installation *(continued)*

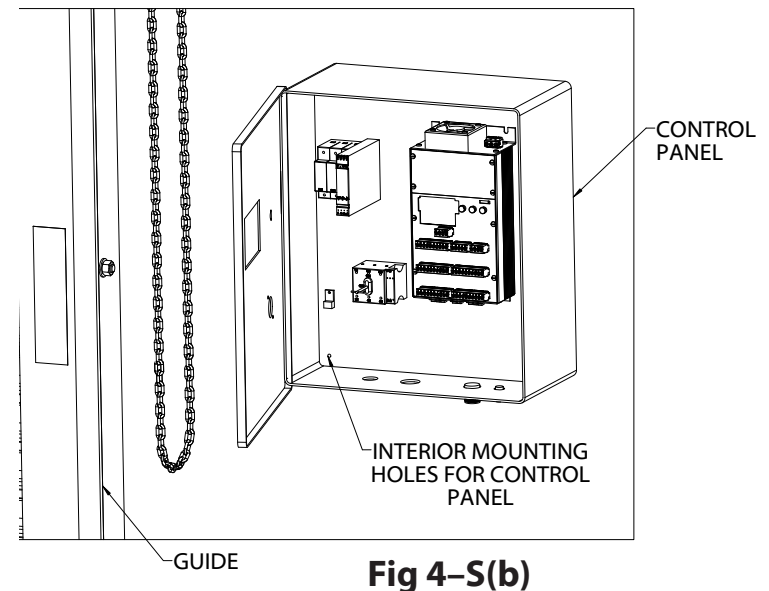
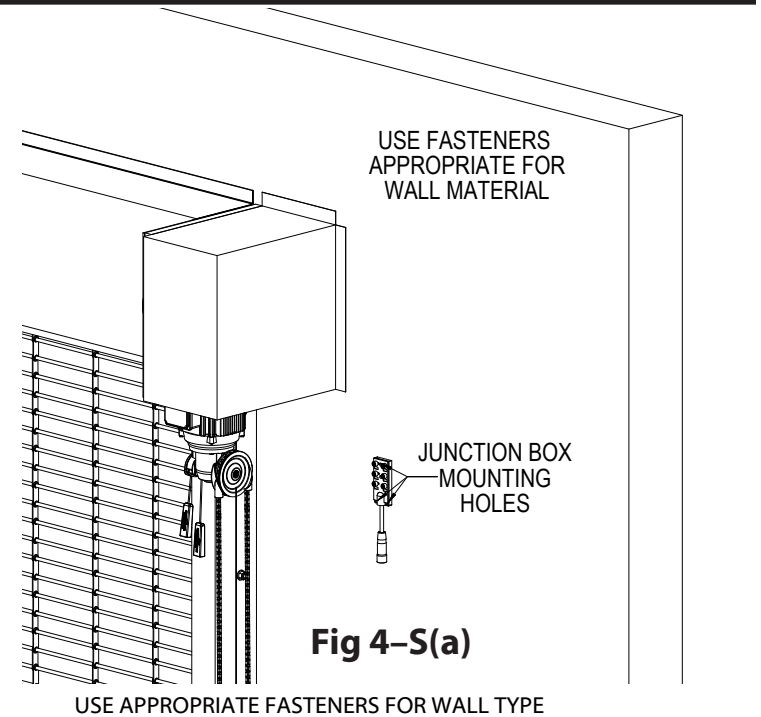
### **⚠ DANGER**

LINE POWER should **NOT** be installed at this time. In the following steps electrical components will be physically mounted. Ensure that all incoming power supplies have been de-energized prior to beginning work on attachment of Model 600 ADV electrical control systems. Use proper Lock Out/Tag Out procedures. **Do NOT connect components to electrical supply until directed to do so.**

## 12. MOUNTING AND CONNECTING/WIRING STANDARD ELECTRICAL COMPONENTS

This step encompasses the installation and wiring of several components;

- Junction Box,
  - Control Panel,
  - Photoeye
- B.** Find a suitable and easily accessible location for the **Junction Box, Fig. 4-S(a)**.
- Locate Junction Box on the wall near the motor, but **OUTSIDE** the end cover. Verify component cables will reach before mounting Junction Box and that the end cover does not interfere with access to Junction Box.
  - Away from heat sources.
  - With no interference of moving parts of the grille system.
  - Where cables can be well secured while preventing unnecessary strain.
  - Use the Junction Box exterior mounting fixtures to mount to wall. (Fasteners not provided.)
- C.** Find a suitable and easily accessible location for the **Control Panel, Fig. 4-S(b)**.
- Adjacent to the grille, on the wall, about 5 feet above the floor at the center of the panel (roughly eye level). It may be mounted higher in retail applications to reduce tampering.
  - Where all moving parts of the grille system are visible while at the control panel.
  - Away from heat sources.
  - With no interference of moving parts of the grille system.
  - Where cables can be well secured while preventing unnecessary strain.
  - Mount the Control Panel to the wall. (Fasteners not provided.) Use supplied mounting tabs as necessary.





## Installation (continued)

### 12. MOUNTING ... (continued)

**D. Photoeye assemblies** are factory mounted to their protective shields. Attach to guides as follows, **Fig. 4-S(c)**.

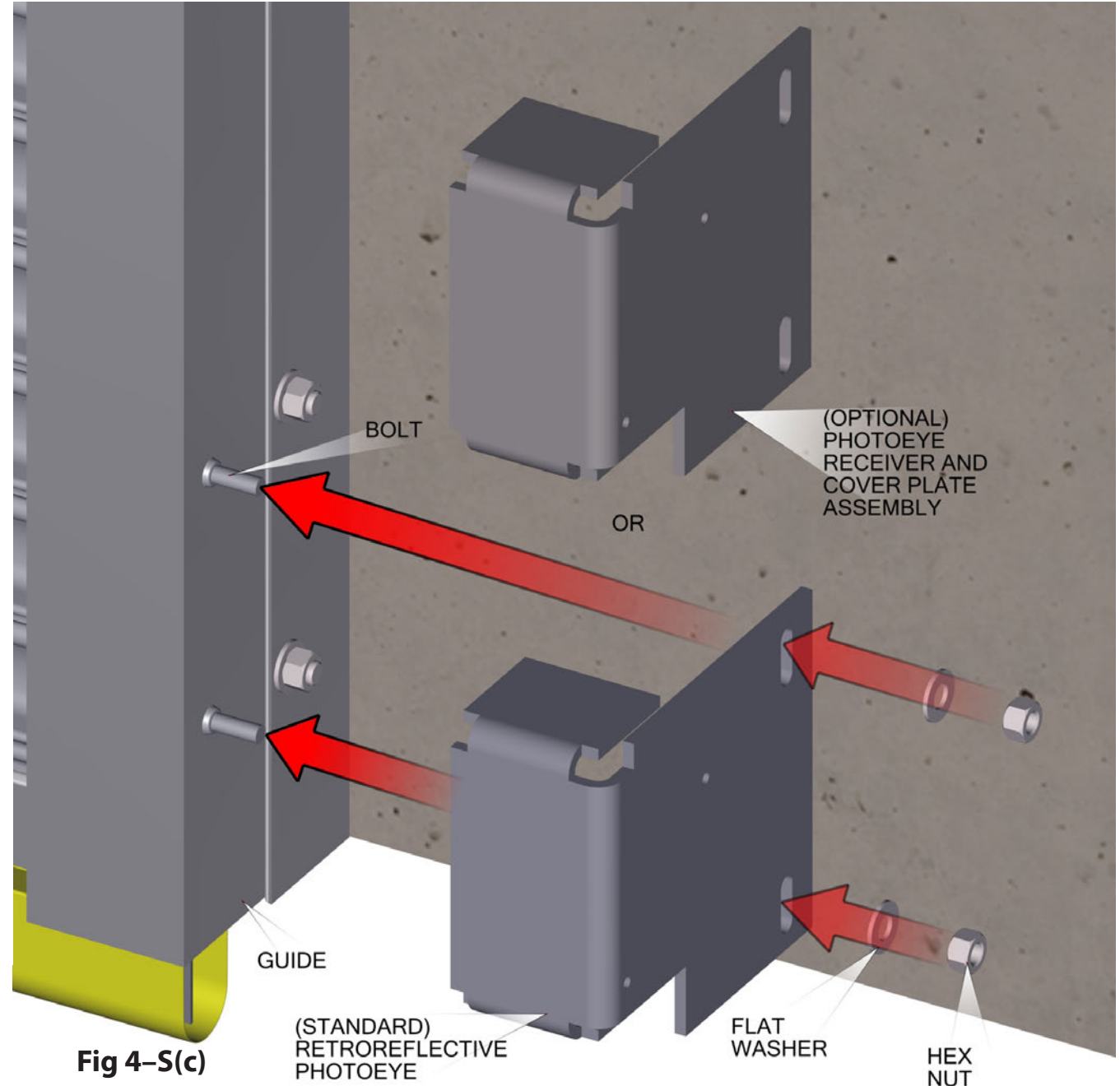
**1.** Mount Retroreflective photoeye or optional photoeye receiver (prewired cable) to the lowest guide assembly bolt (Drive / controller side) such that the Photoeye is aimed to the opposite guide. Route the cable up and plug into the junction box Position 4 labeled "Photoeye RX."

See **Fig 5-J** page 29.

**2.** Mount the photoeye reflector or optional photoeye transmitter to the lowest guide assembly bolt on the opposite guide directly across from the photoeye / receiver. (Optional thru beam only) Route the wire up the guide and over the header to the Junction box to connector position 3 labeled "Photoeye Tx".

See **Fig 5-J** page 29.

**3.** Photoeyes will be aligned later, when power is applied to the Control Panel. See page 30 Photoeye Adjustment.



**Fig 4-S(c)**

# Installation *(continued)*

## 13. LOW VOLTAGE WIRING

A. Connections to the grille are completed by attaching the two screw-in cables to the control panel's base, **Fig. 4-T**.

**1. 5 pin cable connector**

- Encoder

**2. 12 pin cable connector**

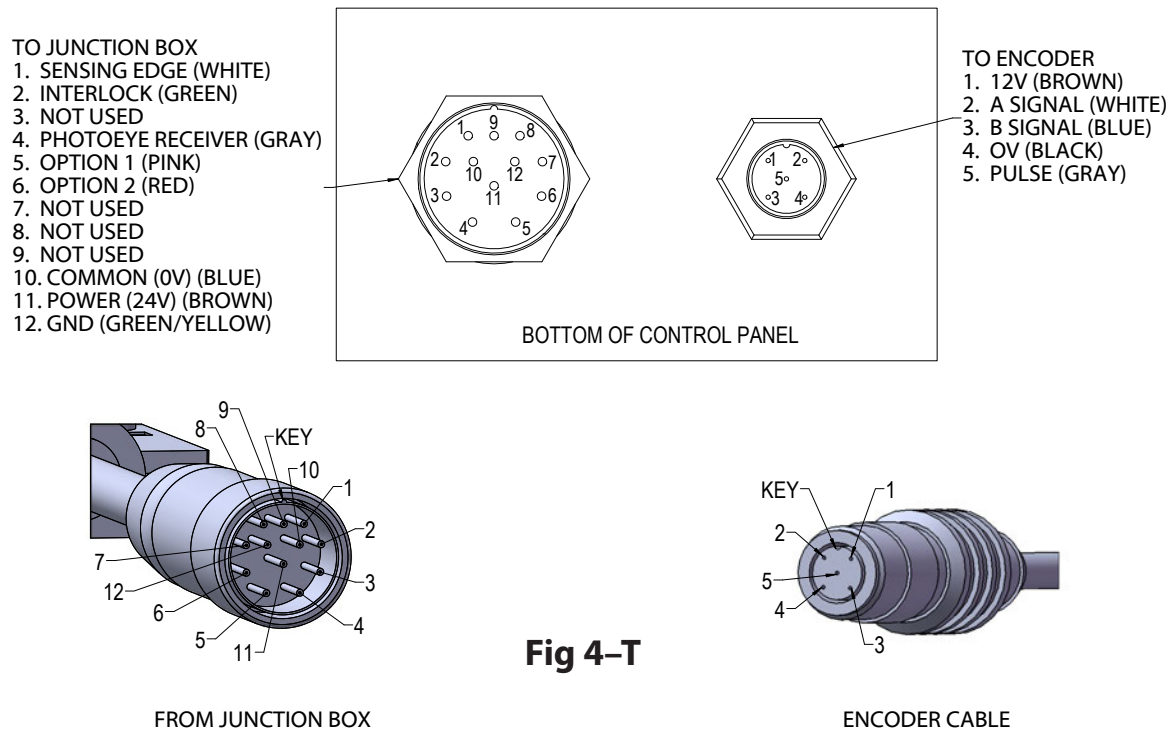
- Photoeye Receiver
- Photoeye Transmitter
- Sensing edge
- Optional Input 1
- Optional Input 2

**3. Two options may be connected to the Junction Box by the installer. Additional options must be wired to the spare inputs on the Control panel. Use the corresponding option inputs.**

- Radio Remote to the Junction Box connector 6 labeled "Option 2".
- Floor loop to the Junction Box connector 5 labeled "Option 1".
- Motion Detector to the Junction Box connector 5 labeled "Option 1".
- Wall mounted push button stations to the main Control Panel

**Fig. 8-J** on page 46.

Note: When installing push buttons, use the 24V supplied by the Control Unit as the common.



**Fig 4-T**

## Installation *(continued)*

### 14. MOTOR & POWER WIRING (HIGH VOLTAGE) (These tasks are also diagrammed in **Fig. 5-D, 5-G & 5-H** on pages 24-26.)

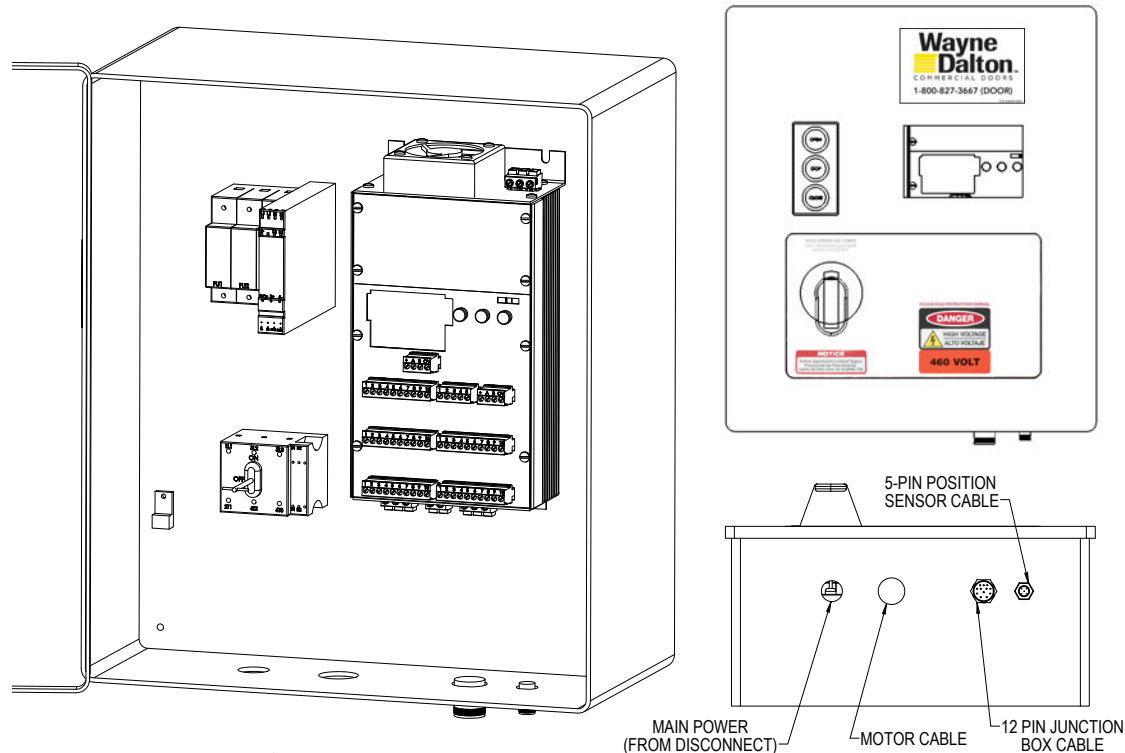
- A.** Route **Motor Power Cable** (provided, factory wired to motor) through water-tight fitting in the SECOND hole from left side of Control Panel bottom.
1. Connect the lighter gauge, twisted pair wires to the blue colored **Motor Brake** terminals next to the disconnect switch. Either wire can connect to either terminal. It is labeled "B1" and "B2".
  2. Connect the green and yellow ground wire, the braided cable shield and the non-insulated ground wire together to the Green and Yellow terminal.
  3. Connect the thicker motor wires to Terminals T1, T2 and T3 on the green screw connectors on the bottom left of the control unit. The order doesn't matter since the motor rotation can be changed using the internal programming during Set-up in **Section 6**.

## **⚠ WARNING**

**Before beginning this phase of installation, ensure POWER SUPPLY is disconnected! A licensed electrician must perform the following step.**

**A licensed electrician must perform the following step.**

- B.** Route **Main Power Cable** (not provided) through a water-tight fitting (not provided) in the FIRST hole from the left side of the Control Panel bottom.
- Connect 3-phase power lines to the disconnect. Connect the ground wire to the Ground Terminal to the left of the disconnect.



**Fig 4-U**

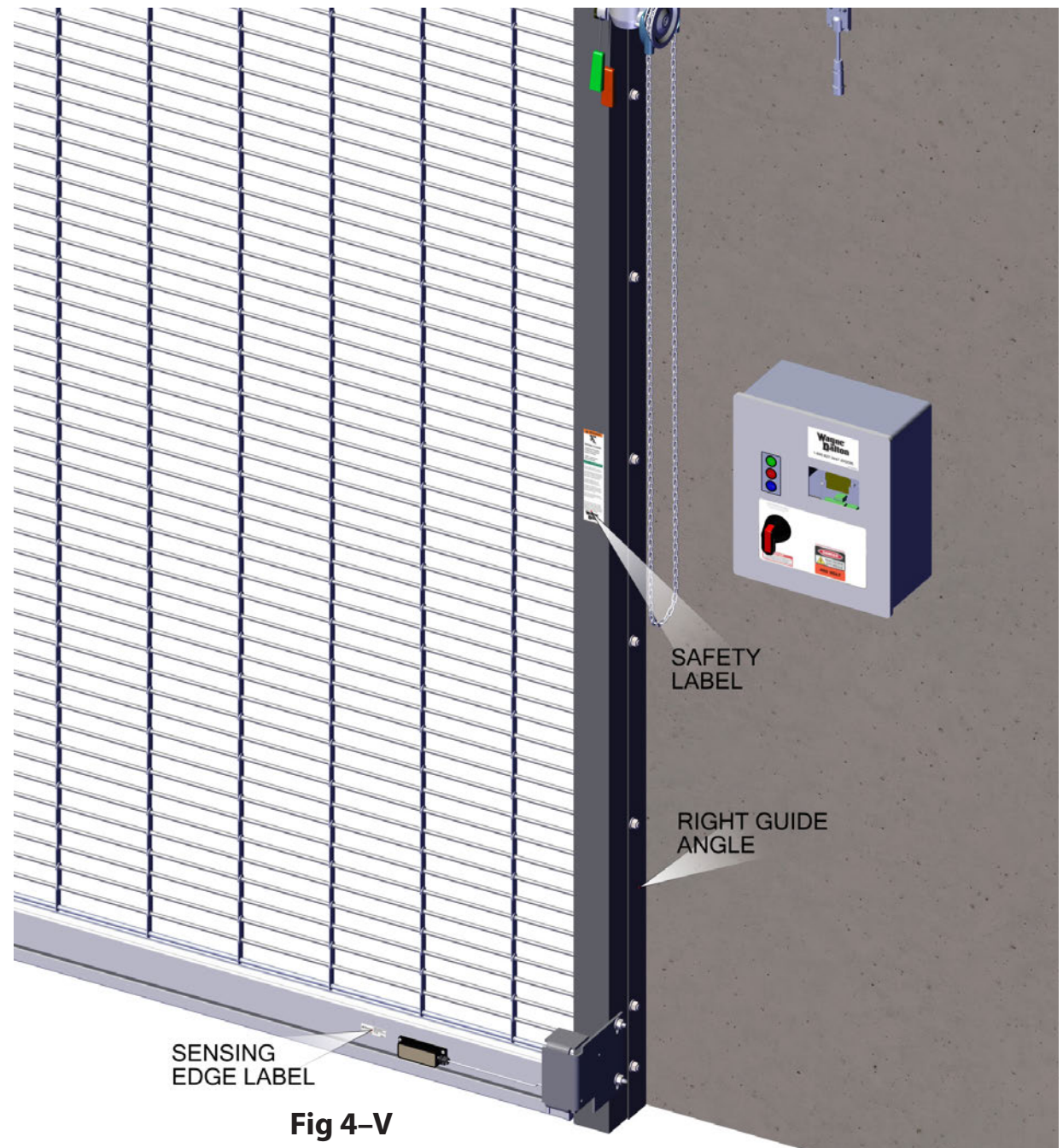
## Installation *(continued)*

### 15. INSTALL SAFETY LABELS, Fig. 4-V

Product safety labels must be installed.

- A. Find Safety Labels in hardware box.
- B. Attach **Sensing edge** Safety Label to the bottom bar.
- C. Place remaining Safety Label at a readable height on grille drive side guide or jamb.

**NOTE:** Product safety labels should be periodically inspected and cleaned by the product user as necessary to maintain good legibility. Order replacement safety labels from the grille manufacturer as required to maintain legibility.



**Fig 4-V**

## 16. LEVEL DOOR (IF NEEDED)

- If during previous step the door rolled up level and straight, skip this step.

**A.** Check that guides are plum, square, level, and are properly mounted onto floor and wall.

**B.** Check that the pipe is level.

**C.** Check that the attachment of the curtain is straight on the pipe.

If all of the above is correct and the door still rolls up out of level, a shim may need to be added, as shown in **Fig. 4-W**.

Shim materials:

- A piece of rubber is the desired material for a shim.
- A piece of cardboard could be used but may deteriorate over time.
- Use a 1/8" x 6" x 6" thick piece of material and increase thickness or pieces depending on the result acquired, as shown in **Fig. 4-X**.

Application of shim:

- To determine the side in which the shim will be applied, the door will need to be in the open position.
- When facing the door, the bottom bar will be unlevel. The lower side of the bottom bar will be the side in which the shim needs to be placed.
- The hood may need to be loosened or removed for the application of the shim.

To apply the shim, two laborers might be required.

Installing the shim:

- D.** Close the door fully.
- E.** When door is at bottom make sure door is in hand chain mode.
- F.** Turn off the power to the motor (if applicable) to ensure safe application of the shim.
- G.** Backwind the door using the chain. Lock chain in place using chain keeper.

### **⚠ WARNING**

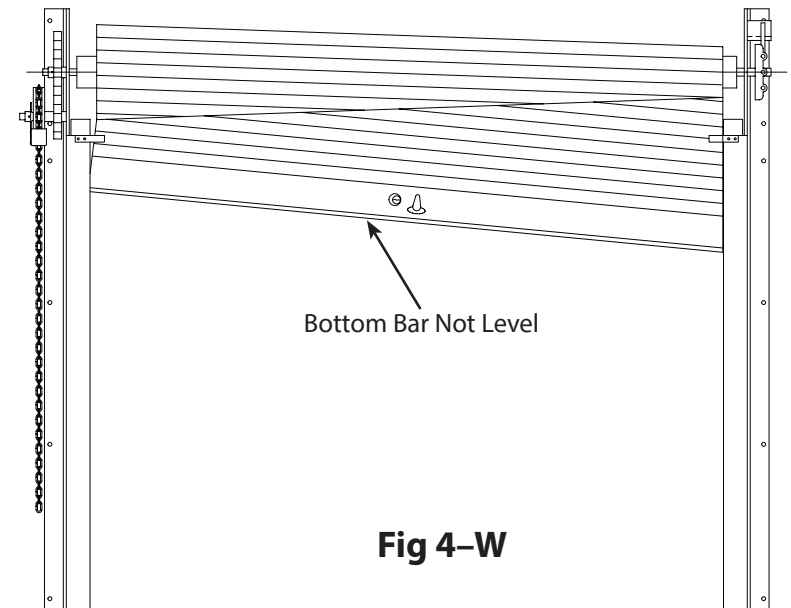
**When the door is wound backwards there is a force in which the door will want to wind forward. Secure the door in this position by locking hand chain onto chain keeper to prevent injury.**

**H.** As the curtain is wound backwards apply the shim to the lower side between the pipe and slats or on the ring of the low side.

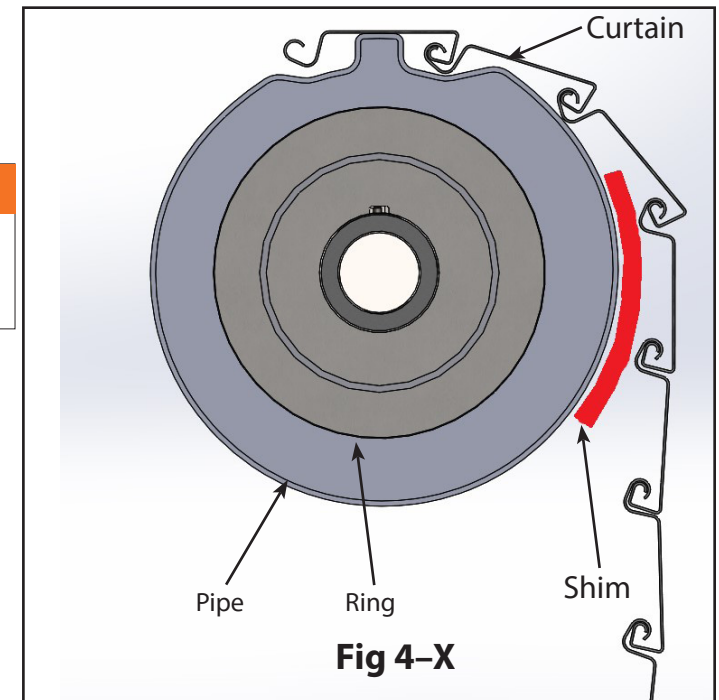
**I.** Restore power to the motor (if applicable).

**J.** Check the level of the bottom bar while door is in the open position. If it is not level, add a second shim and check again.

**NOTE:** If the door has wind locks there may be some stacking interference in the wind locks as the door is wrapping during operation. This is a normal characteristic. For wind lock applications the doors bottom bar should be level at the open position.



**Fig 4-W**



**Fig 4-X**

## Installation (continued)

### 17. PRE-HOOD CHECK LIST

- A. Operate the grille manually several times. Make sure the endlocks or windlocks are not rubbing endplates through the entire travel of grille.
- B. Check that the bottom bar is level at top and bottom and the curtain is not binding against the back of the guides.
  - If curtain is level at bottom but not at top, place shims between the curtain and barrel on the low side.
- C. Verify good mechanical connection and tightness of fasteners, i.e., guides, headplates, set screws.
- D. Position the grille at the half open position.

**NOTE:** Hood and Brush Seal installation can be delayed until the last step to allow easy access to curtain during wiring set-up and final adjustments.

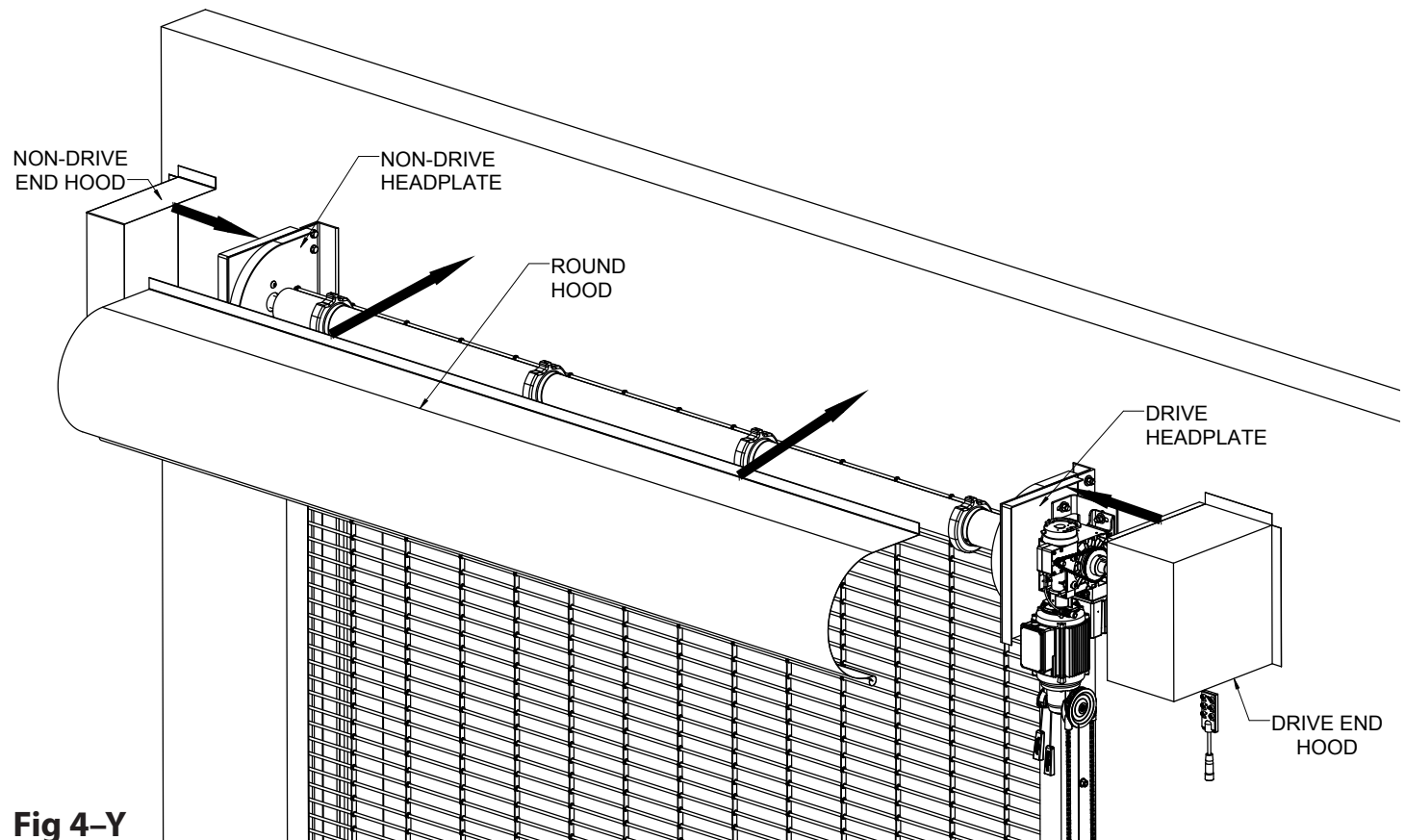
### 18. INSTALL HOOD (interior) (If you have an exterior application see section 7 page 4)

- A. Pre-drill the hood flange at 18" spacing for wall mounting screws. Hole diameter is dependant on the size of the wall fasteners (not provided) used to attach hood to wall.
- B. Place the hood over the hood bands or straps on the headplates (and, if provided, hood supports) and **against** the wall, **Fig. 4-Y**.
- C. Fasten the hood to the hood bands or straps.
  - At top, bottom and middle of the bands, drill 3/16" diameter holes through the hood and hood bands or straps on the headplates. Fasten the hood to the hood bands with self-tapping screws (provided).
- D. Fasten the hood to the wall.
  - Place fasteners using the pre-drilled holes (wall fasteners not included).

#### HOOD SUPPORTS NOT SHOWN

**NOTE:** Install hood supports (if provided) at even intervals across header. Number and placement of hood supports will vary with hood type and width.

\* For EXTERIOR hood installation see Section 7: Special Grille System Features, Exterior Hood Installation on page 44.



**Fig 4-Y**

## Installation *(continued)*

### 19. INSTALL BRUSH SEAL (optionally purchased)

Brush Seal is an optional component purchased separately and does **not** come with grille.

- A. Place curtain in fully closed position.
- B. Position brush seal against grille lintel as shown, **Fig. 4-Z**.
- C. Using appropriate fasteners (not provided) for your type lintel and with the holes drilled in the extrusion as a guide, fasten brush seal to lintel.

### 20. INSTALL MOTION SENSOR (optionally purchased)

Motion Sensor is an optional component purchased separately and does **not** come with grille.

- A. Follow the installation instructions accompanying the Motion Sensor.
- B. Install wiring per wiring diagram **FIG 5-OD** page 32.

### 21. INSTALL LOOP DETECTOR (optionally purchased)

Loop Detector is an optional component purchased separately and does **not** come with grille.

- A. Follow the installation instructions accompanying the Loop Detector.
- B. Install wiring per wiring diagram **FIG 5-OE** page 32.

### 22. INSTALL RADIO CONTROLS (optionally purchased)

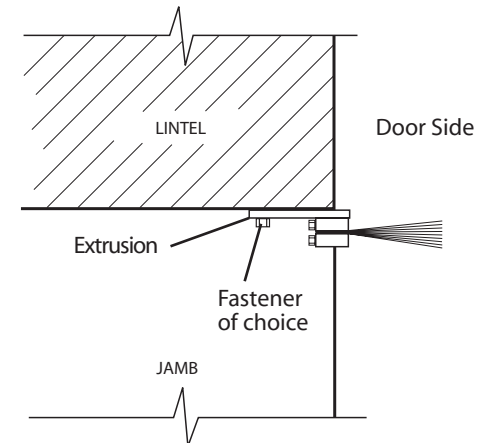
Radio Controls are an optional component purchased separately and does **not** come with grille.

- A. Follow the installation instructions accompanying the Radio Controls.
- B. Install wiring per wiring diagram **FIG 5-OC** page 32.

### 23. INSTALL WALL MOUNTED PUSH BUTTON (optionally purchased)

Wall Mounted Push Buttons are an optional component purchased separately and does **not** come with grille.

- A. Install wiring per wiring diagram **FIG 8-J** page 47.



**Fig 4-Z**

## **CAUTION**

Making the checks outlined below will help to ensure that the Model 600 ADV grille and operator are installed properly.

### **CHECK LIST**

- Is the grille level, square and plumb?
- Are all the bolts tightened?
- Are limit switch sprockets properly aligned?
- ARE ALL BEARING AND SET COLLARS POSITIONED, ARE SET COLLARS AND BEARING SET SCREWS TIGHTENED?
- Has all the rigging equipment, ropes, straps, etc. been removed?
- Are all safety labels and tags in place?
- Are all cable connections in the proper locations?

## Section 5

### Wiring

All Advanced Performance Service Grille models are available in 220/240VAC 1-phase or 230V AC and 460V AC 3-phase as input voltage options. 575V AC 3-phase input power is available with the use of a 575V AC/460VAC step-down transformer for all Advanced Performance Service Grille models. **YOUR LOCAL CODES MAY REQUIRE THAT THE INCOMING POWER TO YOUR MODEL 600 ADV ADVANCED ROLLING GRILLE SYSTEM HAVE A LOCK-OUT / TAG-OUT EQUIPPED FUSED DISCONNECT SWITCH (TO BE FURNISHED BY OTHERS) WITHIN EYESIGHT OF THE GRILLE'S CONTROL PANEL.**

Incoming power must meet all NEC and local building codes, plus be properly sized for the control panel's amperage rating on the nameplate. To reduce the risk of electrical shock, the chassis of the control panel must be properly grounded.

#### CAUTION

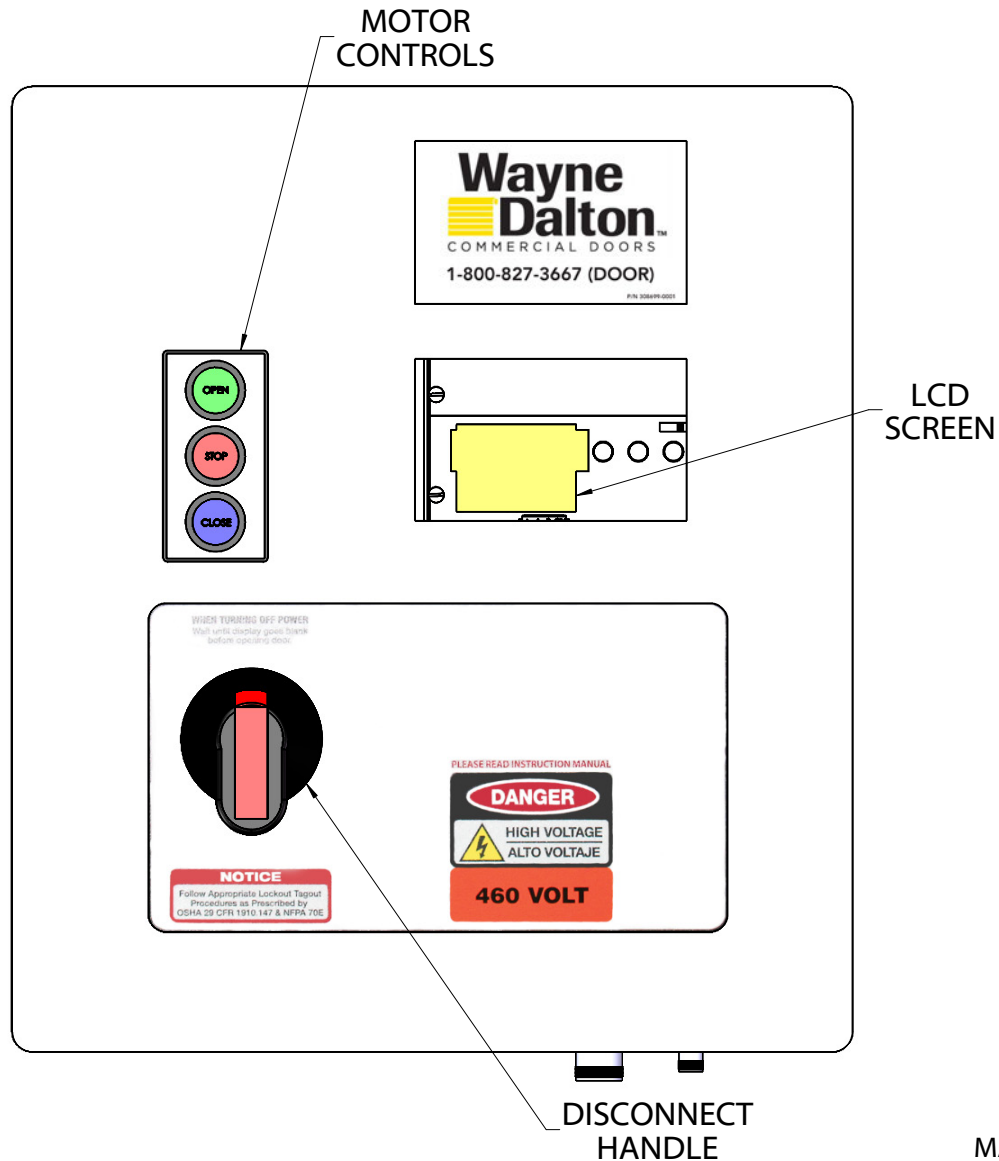
The Model 600 ADV Advanced Rolling Grille System must be supplied by a properly grounded voltage supply, e.g. 220/240 VAC 1-phase or 208/230/460/575 VAC 3-phase. Floating (Open Delta) ungrounded voltage supply sources should not be used. For 480 VAC, 240 VAC or 120 VAC unbalanced Delta systems should **NOT** be used. Voltage unbalance is a common occurrence on delta supply systems, which power both single and 3-phase load. This can lead to unequal voltages on each phase leg. Voltage unbalance can cause deterioration of motor performance such as loss of torque, overheating, decreases in the winding insulation life, and can cause motor starter contacts on the control panel to permanently "weld" closed. Voltage unbalance can be caused by inadequate conductor sizing, delta transformer sizing, excessive single phase loads, poor grounding or intermittent high resistance faults which may cause destructive over-voltages to occur. If a 240 VAC 3-phase delta system must be used, it is strongly recommended that this voltage be transformed to a 220/240 VAC 1-phase grounded wye system. Any single phase loads should be evenly distributed as much as possible between the 3 phases. Consult a licensed electrician if you have any questions.

***Wayne Dalton's warranty will not cover damage caused by failure of the motor, control panel or other electrical components due to the use of an inadequately grounded system.***

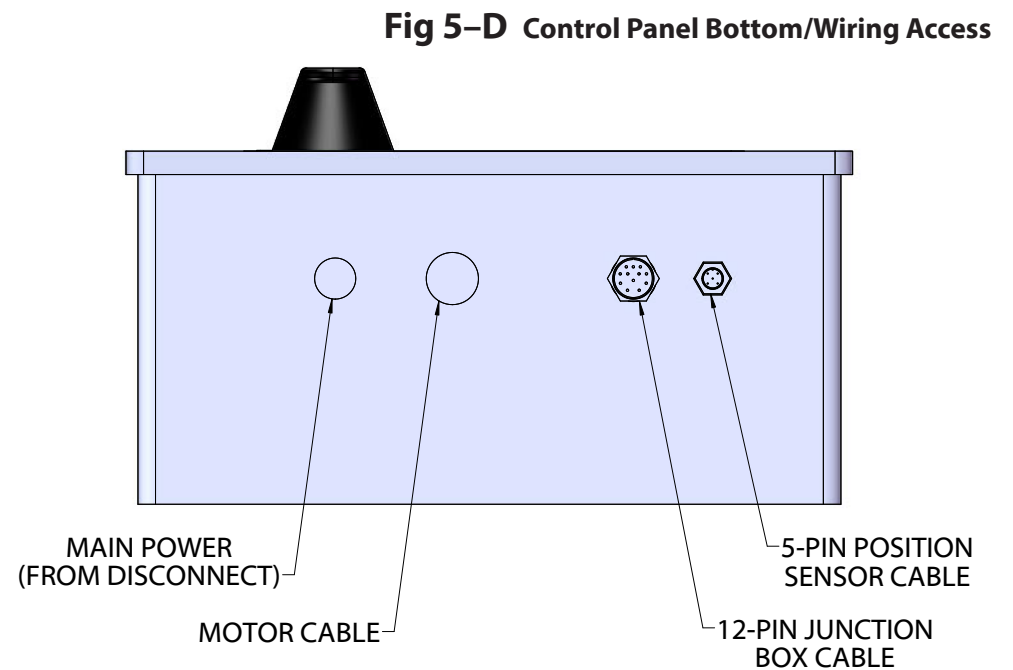


# Wiring Overview

## 1. MAIN COMPONENT OVERVIEW, Fig. 5-C AND 5-D

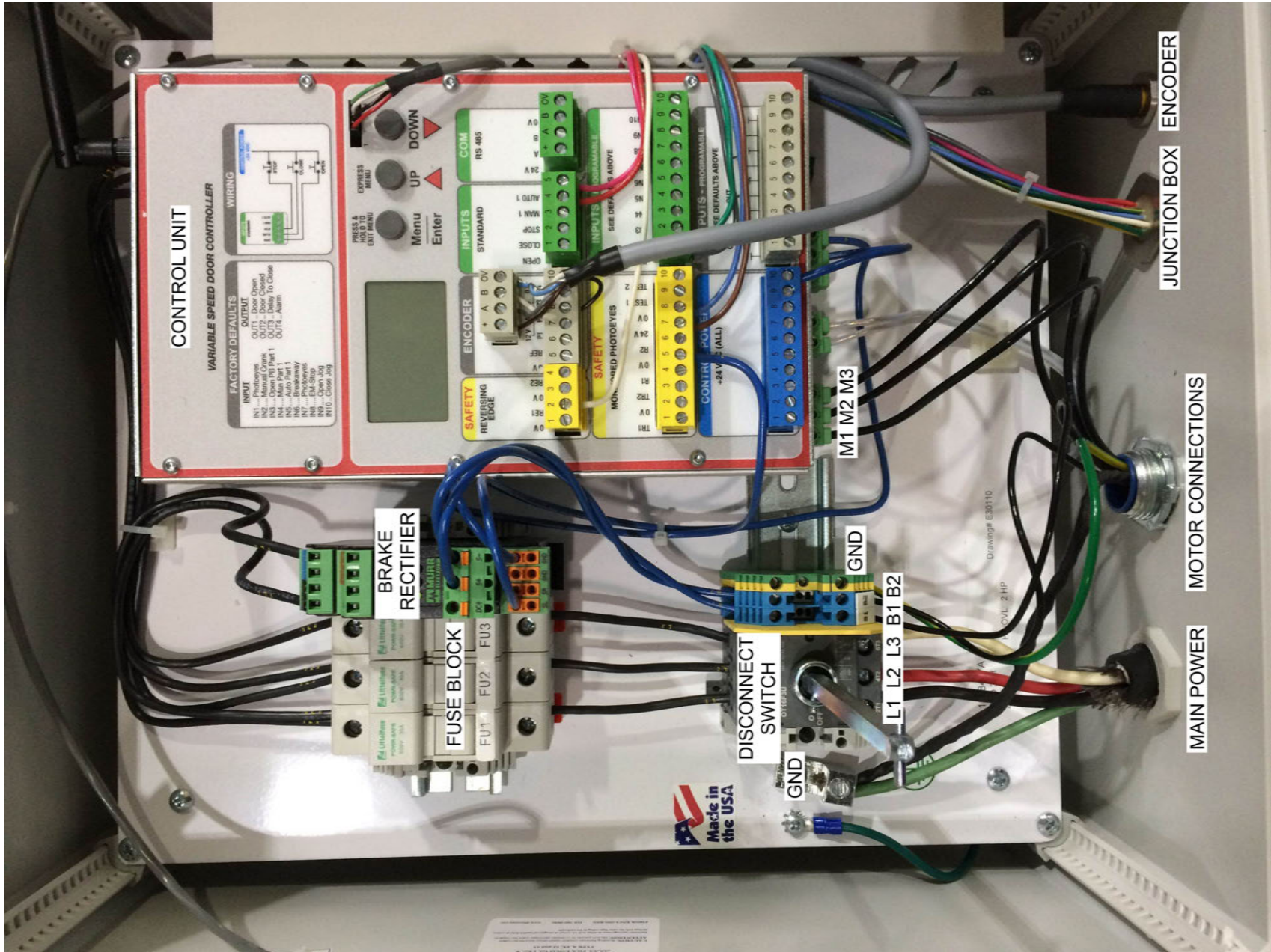


**Fig 5-C Control Panel Front Cover**



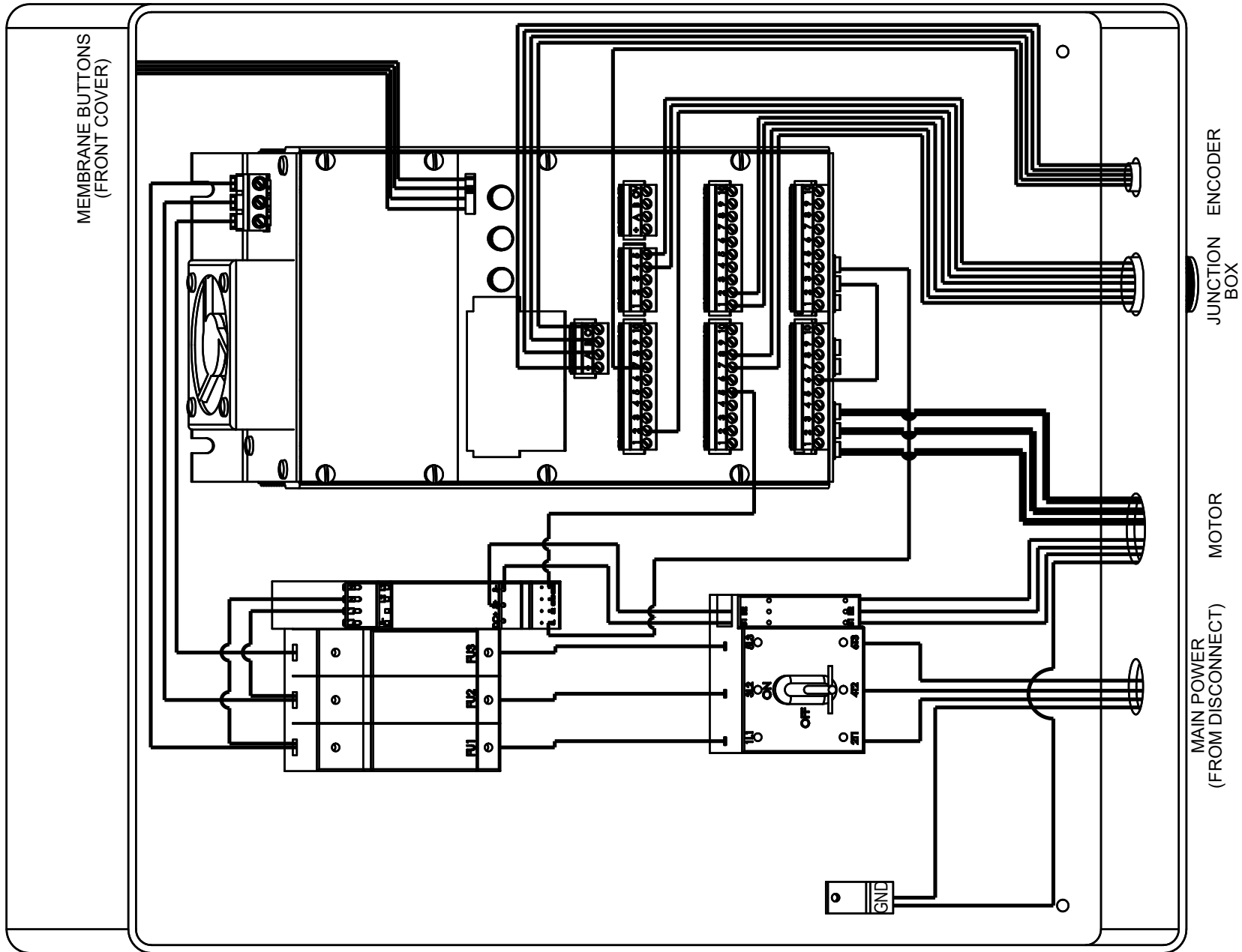
# Wiring Overview (continued)

Fig 5-G Control Panel Contents (See also FIG 8-H)



# Wiring Overview (continued)

Fig 5-H Control Panel Wiring Diagram (480V)

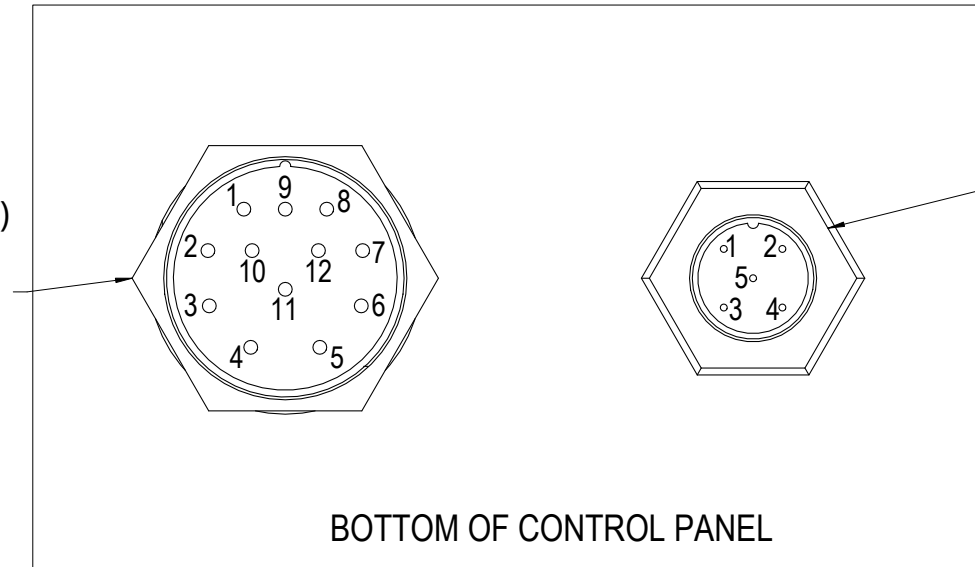


## Wiring Overview *(continued)*

**Fig 5-I Cables to Control Panel**

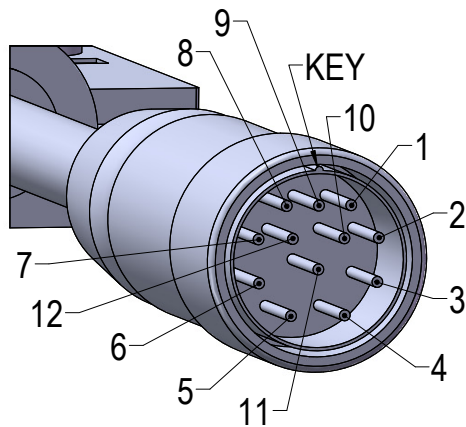
### TO JUNCTION BOX

1. SENSING EDGE (WHITE)
2. INTERLOCK (GREEN)
3. NOT USED
4. PHOTOEYE RECEIVER (GRAY)
5. OPTION 1 (PINK)
6. OPTION 2 (RED)
7. NOT USED
8. NOT USED
9. NOT USED
10. COMMON (0V) (BLUE)
11. POWER (24V) (BROWN)
12. GND (GREEN/YELLOW)

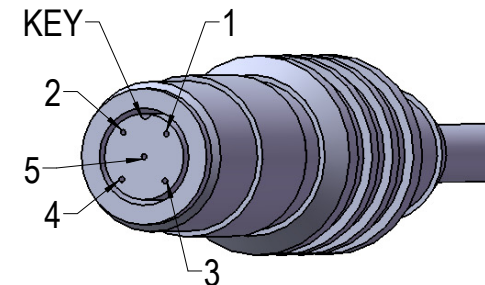


### TO ENCODER

1. 12V (BROWN)
2. A SIGNAL (WHITE)
3. B SIGNAL (BLUE)
4. 0V (BLACK)
5. PULSE (GRAY)



FROM JUNCTION BOX



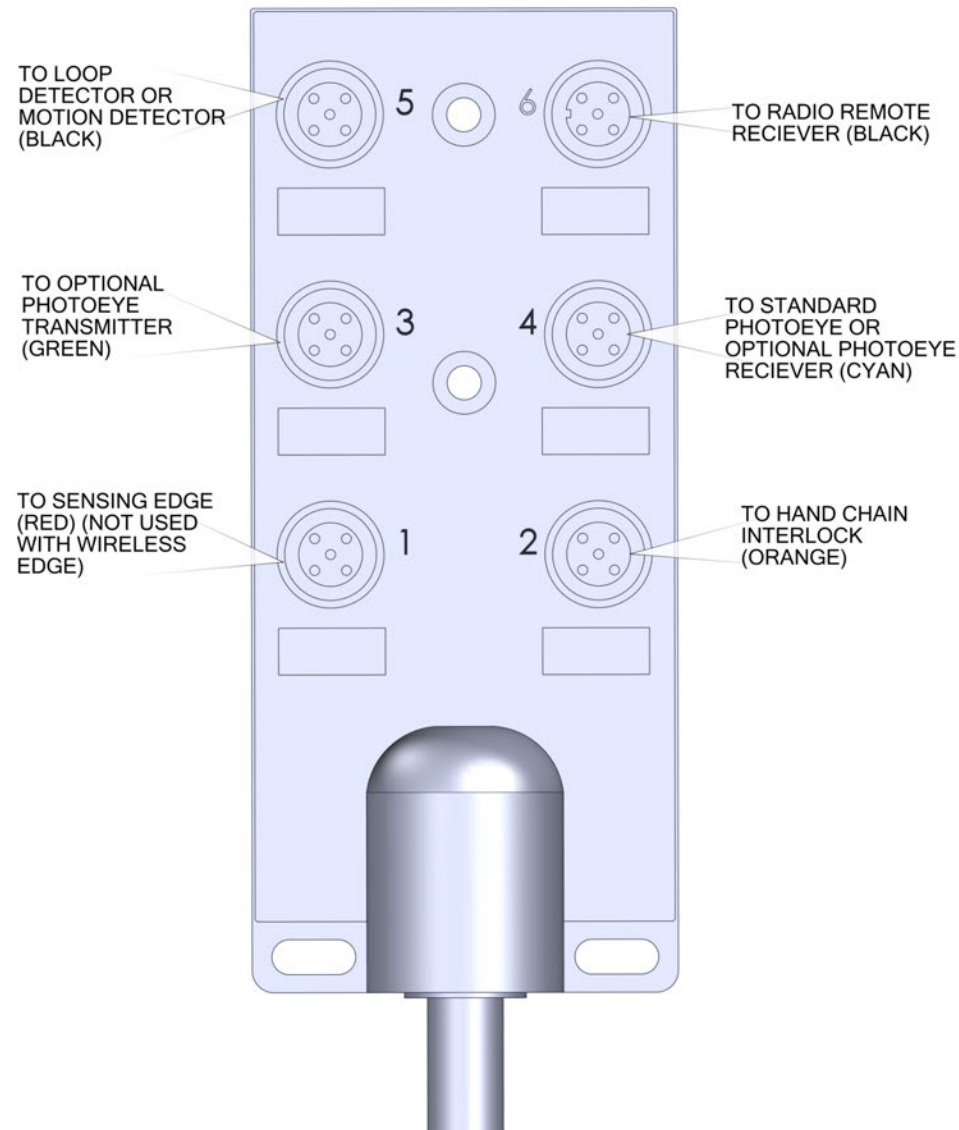
ENCODER CABLE

## Wiring Overview *(continued)*

**Fig. 5-J JUNCTION BOX WIRING**  
Connections for most factory wired external control functions.

**CAUTION**

Ensure all openings into junction box are weather tight to prevent leakage.

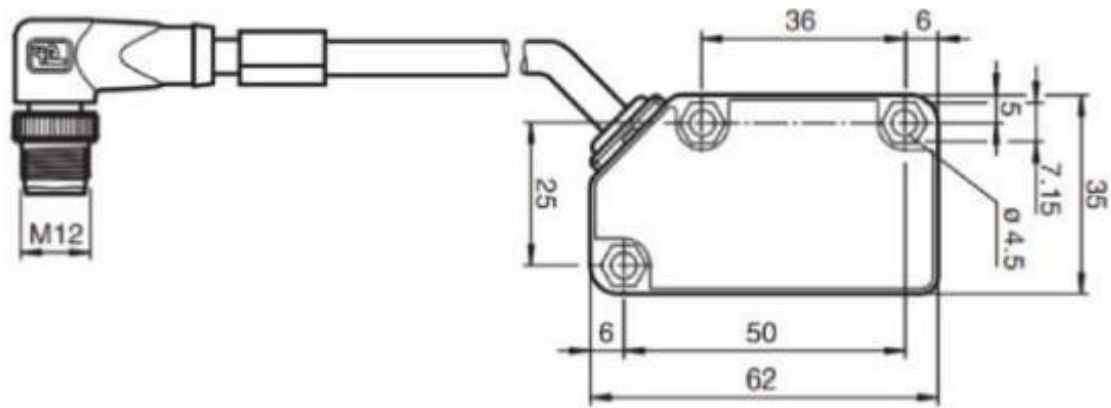


## Wiring Overview *(continued)*

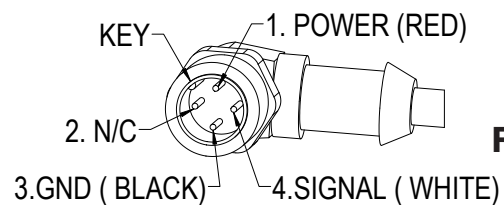
### 2. Photoeye ADJUSTMENT (Retroreflective)

Photoeye wiring connections were completed in a previous step (Mounting Electrical components on page 18).

- Final adjustment of the Photoeyes will be made **after power is supplied to the door system.**
  - Verify the Photoeye green power LED is on, indicates power is on.
  - Loosen the mounting screws on Photoeye receiver and adjust position until the yellow LED on is steadily on. (LED will flash when receiving a weak signal)
  - Lock the mounting screws down, being sure not to move the Photoeyes out of alignment.

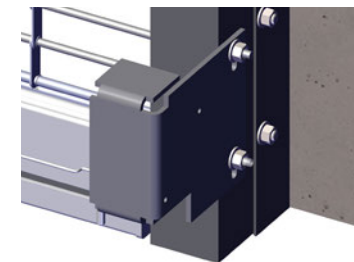


**Fig 5-K**



Photoeye Receiver Cable connects to Junction Box

**Fig 5-L**



**Fig 5-M**

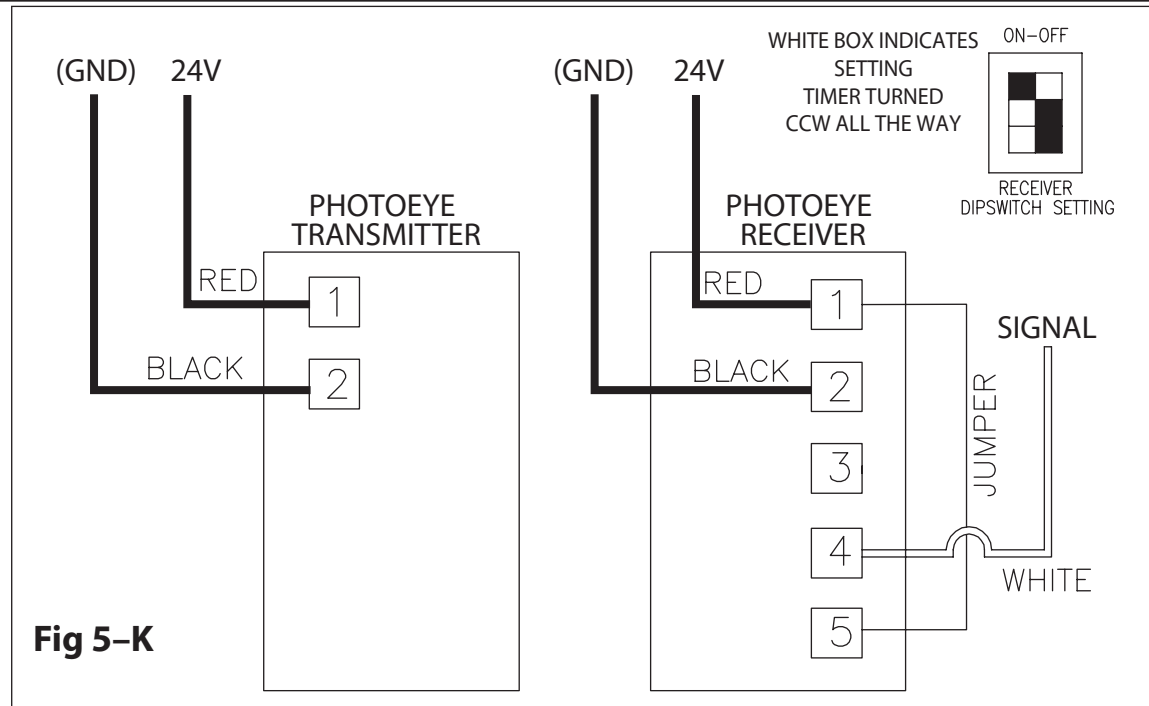
Photoeyes is attached to the protective shield at the factory and must be mounted to the guides using the hardware provided.

## Wiring Overview *(continued)*

### 2. Photoeye ADJUSTMENT (Optional Thrubeam)

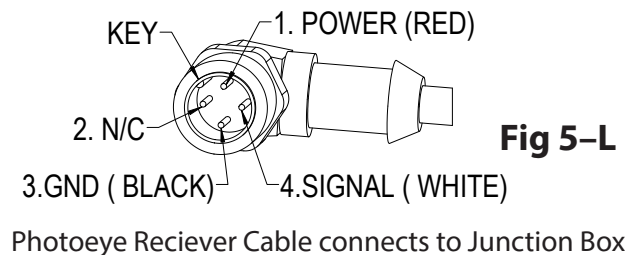
Photoeye wiring connections were completed in a previous step (Mounting Electrical components on page 18).

- Final adjustment of the Photoeyes will be made **after power is supplied to the door system**.
  - Verify the Photoeye transmitter LED is on, indicates power is on.
  - Loosen the mounting screws on both Photoeyes and adjust position until the LED on the receiver is steadily on.
  - Lock the mounting screws down, being sure not to move the Photoeyes out of alignment.

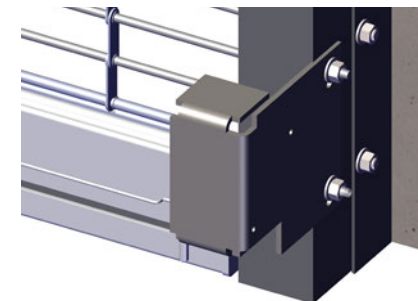


**Fig 5-K**

\* Photoeye cables are wired at the factory with a M12 connector. wire colors are for reference.  
**NO FIELD WIRING REQUIRED.**



**Fig 5-L**



**Fig 5-M**

Photoeyes is attached to the protective shield at the factory and must be mounted to the guides using the hardware provided.

# Wiring *(continued)*

## 4. ENCODER WIRING CONNECTIONS AND SETTINGS

- A) Attach one end of the M12 encoder cable to the encoder.
- B) Attach the other end of the M12 encoder cable to the Control Panel.

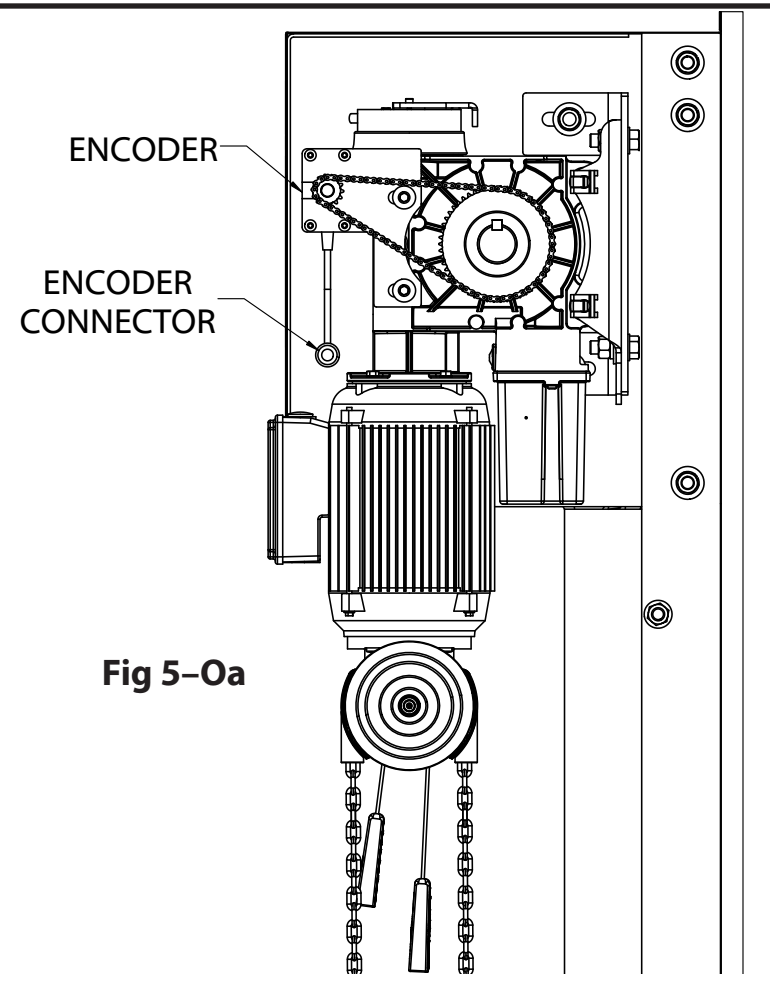


Fig 5-Oa

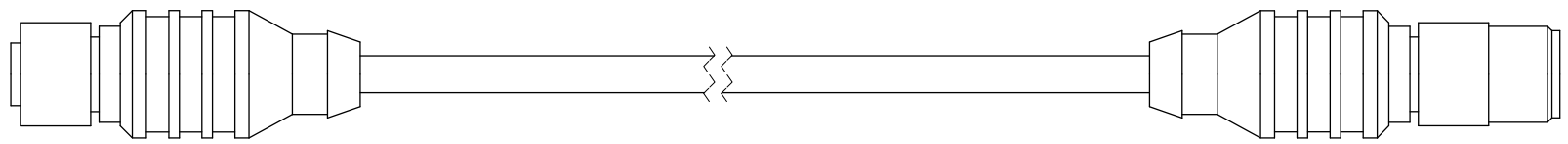
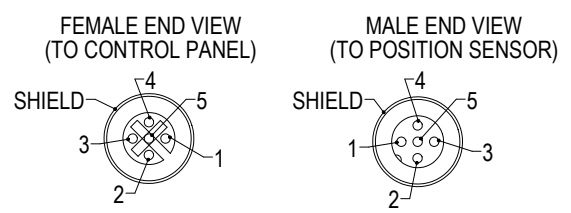
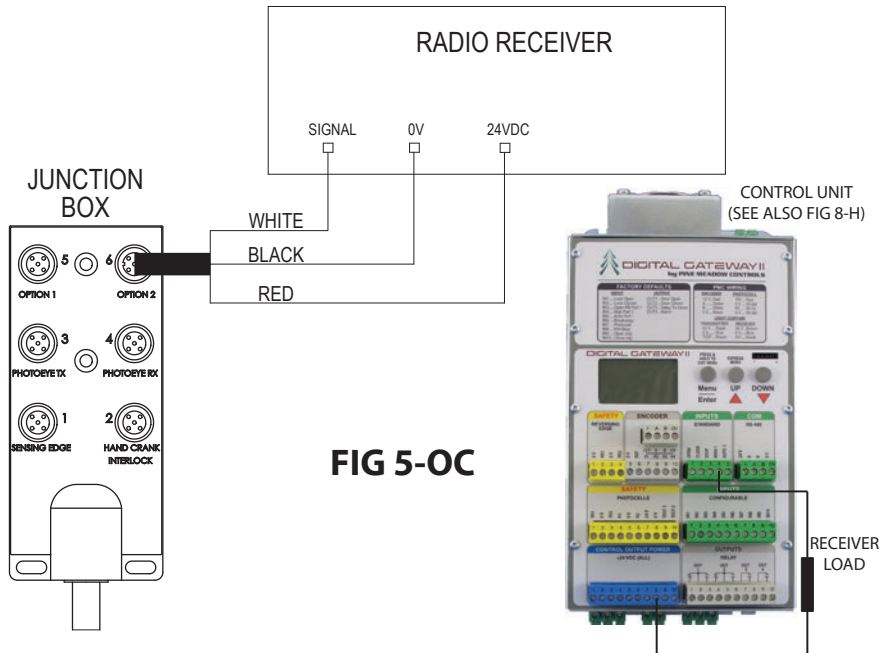


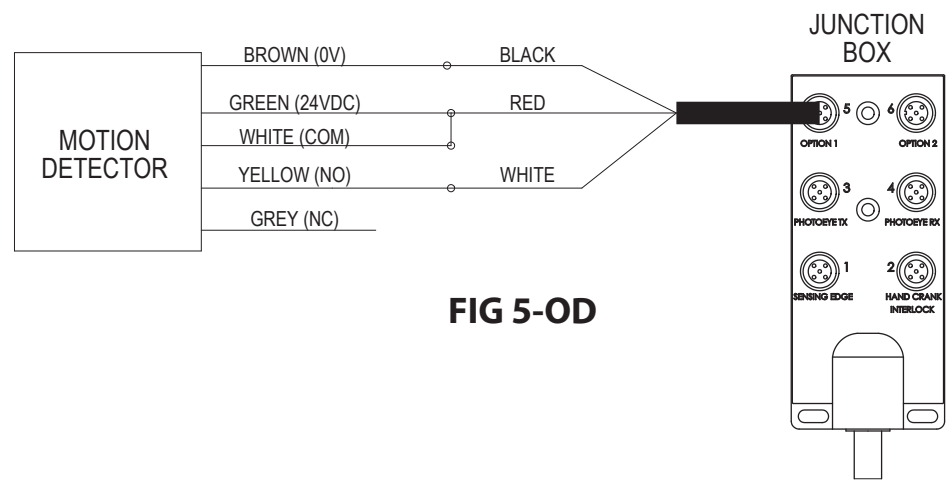
Fig 5-Ob Encoder Cable



# Wiring (continued)

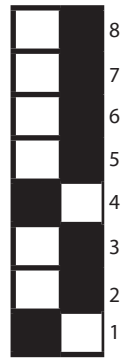


**FIG 5-OC**

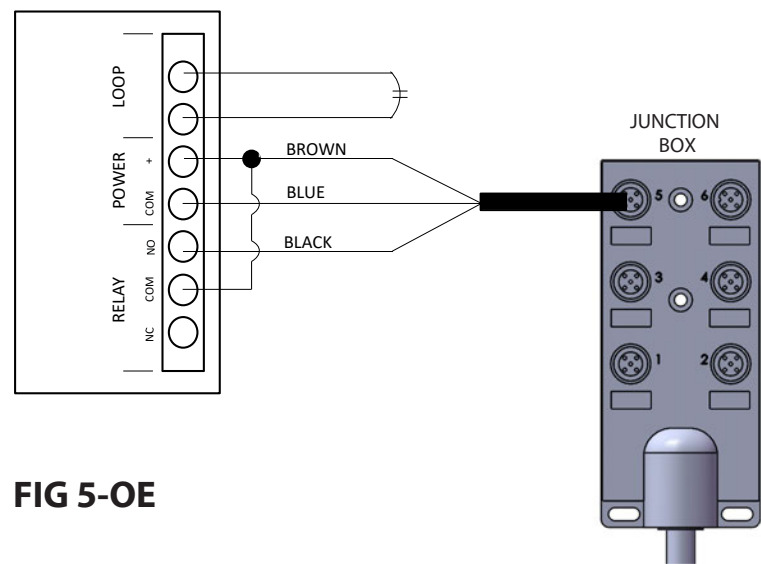


**FIG 5-OD**

## LOOP DETECTOR DEFAULT SETTINGS



WHITE BOX  
INDICATES SETTING



**FIG 5-OE**

## 5. Options wiring and settings

-Wire the supplied cables to the following options as shown in **FIG 5-OC, FIG 5-OD, FIG 5-OE.**

A. For the radio receiver, wire the supplied receiver load into the control unit from MAN1 to 24VDC (blue terminal).

**CAUTION**

Grille will open/close once connected.

1. Access the menu and navigate to system config-> Inputs-> Man1-> Logic.
2. Select NC parameter and exit the menu.

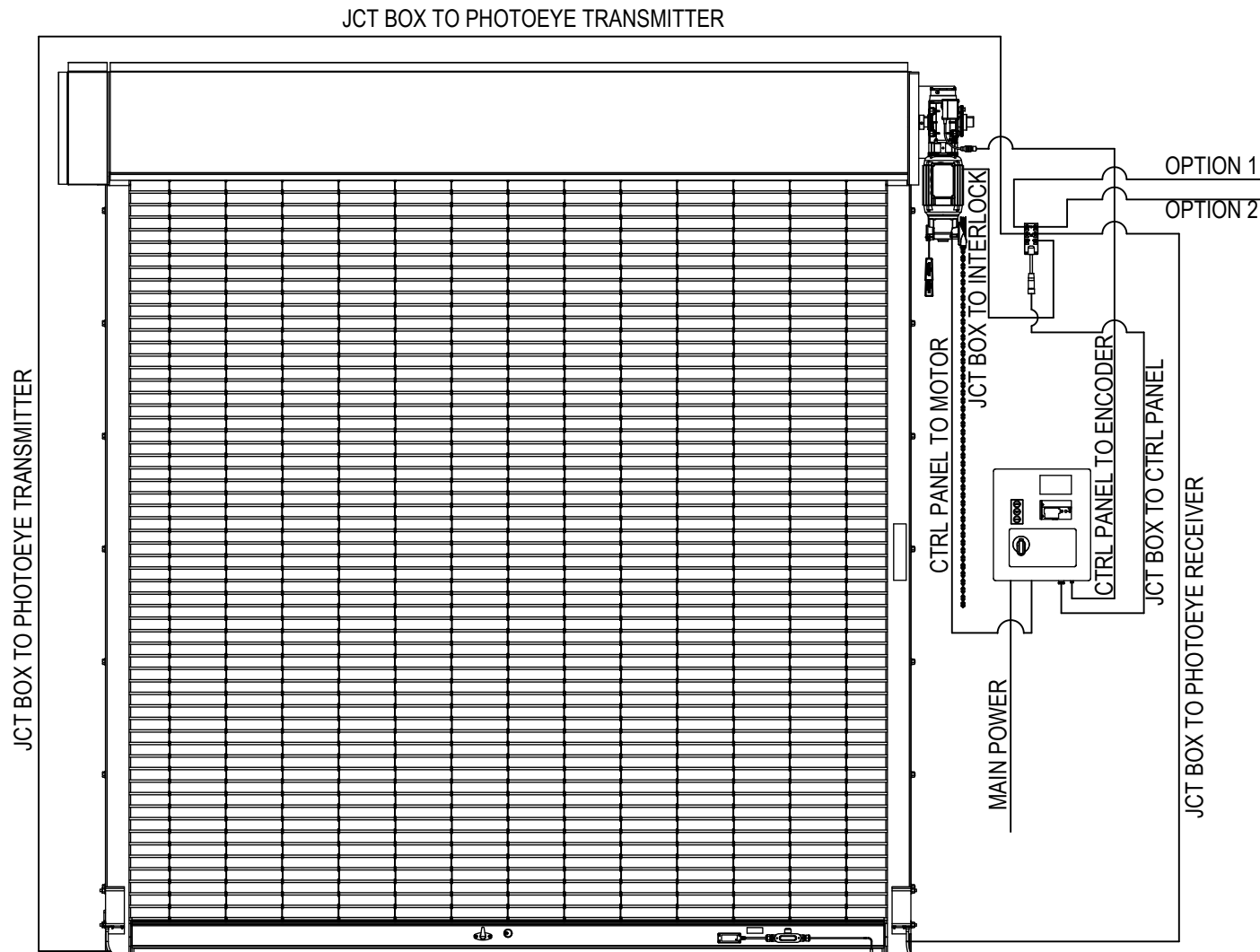
B. The motion detector and loop detector can be operational once wired to the junction box. They are wired for the default configuration.

1. To update the auto close timer, access the express menu->Auto1 Timer.

## Wiring (continued)

### REFERENCE: CONVENTIONAL WIRE ROUTING

**NOTE:** Components/component locations are shown here for reference only. Some parts not shown for clarity. Your unit installation and wire routing may be different.



**Fig 5-P**

Installed wire routing for example only.

## Wiring Check List

After completing the instructions contained in this section, check:

### **WARNING**

Making the checks outlined below will help to ensure that the Model 600 ADV unit is wired properly.

#### **CHECK**

- Double check that all connections are tight.
- Check all cables are secured (not hanging loose where they might become an interference).
- Ensure there are no loose tools or materials inside the Control Panel or Junction Box.

# Section 6

## Grille System

### INITIAL STARTUP PROCEDURE

#### 1. APPLY POWER (LINE VOLTAGE)

Turn the disconnect handle Clockwise to the ON position in order to apply power to the Control Panel. A blue splash screen will pop up displaying the default profile, and controller data (consists of serial number, output capacity, software version, etc). Verify the system motor rating, and power ratings correspond with each other.

NOTE\* The system information can also be accessed in the SYSTEM STATUS > OVERVIEW menu. (see page 35-37)

#### 2. VERIFY PHOTOEYE ALIGNMENT

- A. Verify the RED LED is steady ON, on the Photoeye Transmitter. If the RED LED is **NOT** ON refer to Troubleshooting, Section 8
- B. Verify the RED LED is steady ON, on the Photoeye Receiver. If the RED LED is **NOT** ON, loosen the mounting screws and adjust the Photoeye positions until the RED LED is steady ON. Tighten the mounting screws. If the RED LED does **NOT** come ON review the Photoeye installation steps on page 17. Refer also to Troubleshooting, Section 8.



### ⚠ WARNING

All Entrapment Protection Devices are **OFF** in Emergency Jog and the Limits are **NOT SET**. Devices **OFF** while in Emergency Jog include: Edge Contact, Photoeye, Wall push buttons, Radio Control, Limit Sensors, Loop Detector, or any motion sensor used as either an actuator or an Entrapment Protection Device. Only the Interlock remains active.

Emergency Jog is the manual control for momentary operation of grille via ARROW buttons on the membrane keypad or on the control unit.

**USE CAUTION! WHILE SETTING UP THE Grille IN THIS MODE. Do NOT use Emergency Jog for general grille operation.**

## INITIAL STARTUP PROCEDURE

**3. Initial/Limit Setup** The first time the controller is powered on, you must first set the limits. The LED screen will flash with the error E17, and you must reset the limits. This will also occur whenever the encoder is disconnected from the controller. The encoder, photoeyes, sensing edge, and interlock switch must be connected before the limits can be set. If, for any reason, the limits cannot be set, please refer to troubleshooting section 8.

- A. To enter the Menu, press and hold the OPEN, STOP, CLOSE membrane buttons for 3 seconds. A count down timer on the top left corner of the LED screen will display the remaining time left to hold. Refer to **Fig 6-A** for the complete menu structure.
- B. Holding the Stop button for 1 second will go back up a level in the Menu. Continuing to hold the STOP button will continue to go back up the menu structure until the main screen.
- C. Once in the main screen, a 25 second countdown timer will show on the upper left hand corner. This countdown timer displays how long until the OPEN/STOP/CLOSE buttons will no longer give access to the MENU. Once inside the menu, use the **OPEN button to scroll up, STOP button to enter, and CLOSE to scroll down**. Pressing OPEN/STOP/CLOSE immediately exits the counter.

Note: Instead of using the front panel buttons one can access the menu from the control unit using menu/enter, the ▲, and ▼ buttons.

1. Enter the Menus
2. Scroll down until you reach the LIMIT SETUP and hit enter.
3. Scroll down and enter into Quick Setup. A code request screen will appear. Enter the 3 digit passcode to gain access by scrolling up or down. Your passcode is located on a separate addendum.

NOTE: **Do not** display or freely give out the passcode.

4. Follow the prompts in order to set the open and close limits on the grille. During this time, use the OPEN, CLOSE buttons to move the grille. Again, the STOP button will be used as the ENTER function. If no error has occurred, it will then display QUICK SETUP DONE, otherwise if failed; QUICK SETUP ABORTED and it must be redone. Refer to Trouble shooting section 8 if required.

NOTE: When setting the position, the encoder count will be displayed. Verify the encoder count increases when the grille is moving in the up direction, and does not roll over to the negative position.

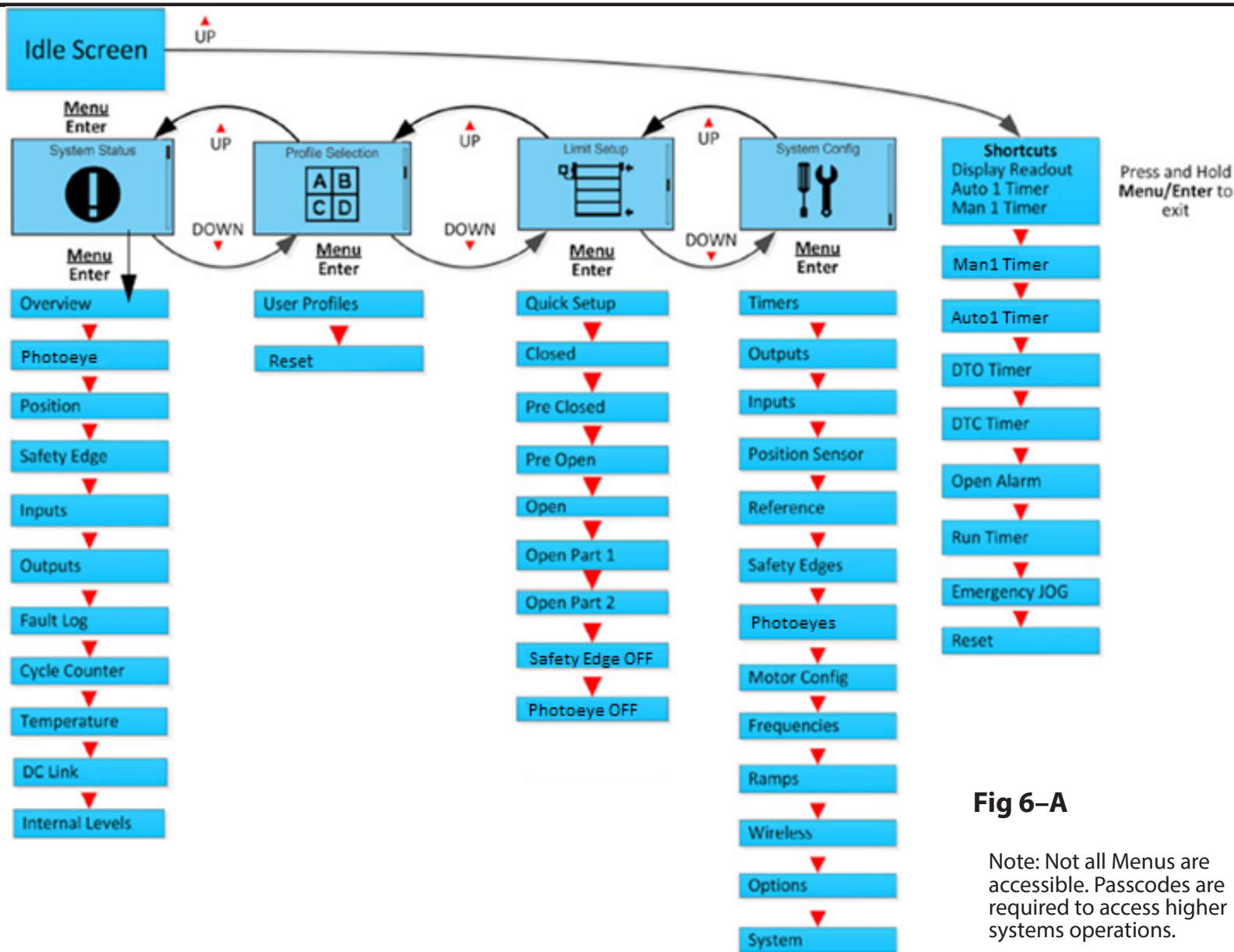
**4. Verification** Test each sensor to make sure the controller recognizes the fault.

- A. Photoeyes -Obstruct the beam with a solid object. Photoeye should reverse grille direction.
- B. Sensing edge -Place a solid object, taller than 12", on the floor and close the grille. Sensing edge should reverse grille direction on contact with object.
- C. Interlock switch - This is a constant activation sensor, pull the hand chain and the grille should not operate and a fault display.

NOTE: all faults and sensor activations are logged into the Fault Log. Access this through the menu SYSTEM STATUS > FAULT LOG in the Controller Menu. To clear faults hold the STOP button for 1 second once the fault has been fixed.

## MENUS

**1. Express Menu** The Express Menu is accessed by scrolling up, when at the idle screen or after exiting the menus. The express menu contains display options, timers, settings reset, and the emergency JOG. The timer functions in the Express Menu are shortcuts to timers in the system configuration menu without the need of a passcode.



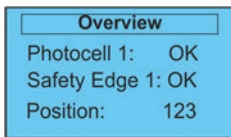
**Fig 6–A**

Note: Not all Menus are accessible. Passcodes are required to access higher systems operations.

## 2. System Status Menu

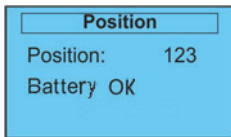
The System Status menu is read-only and provides parameter status displays for use in setup and troubleshooting. The options of the System Status menu are shown and described below. The controller is fully operational within this menu, allowing real-time parameter updates. To use the System Status menu:

- A. Enter the System Status menu
- B. Scroll down and highlight a menu option.
- C. Enter to view the highlighted option.
- D. Press and hold STOP or ENTER when finished to return to the System Status menu.
- E. Repeat to view other parameters if desired.

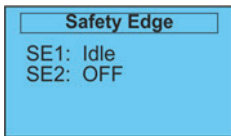


Overview displays status and current position of Photocell and Sensing edge (reversing edge)

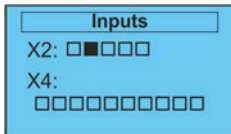
- 1. To view status and current position of photocell
- 2. Sensing edge 2, scroll up.



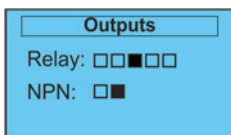
Position shows the internal grille position count. The battery level and status are shown



Safety edge shows the status of the sensing edges (SE).

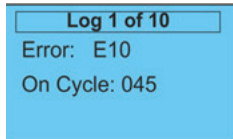


Inputs provides an overview of the controller inputs. Box is marked if the corresponding controller input is active.



Outputs provides an overview of the controller outputs. Box is marked if the corresponding controller output is active.

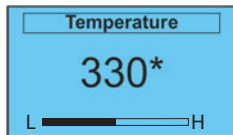
## MENUS *(continued)*



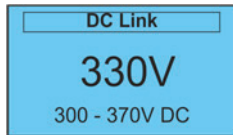
Fault log displays error code and grille operation cycle for the last 10 faults. Scroll up or down to navigate through the fault log.



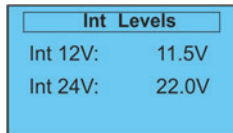
Cycle counter shows the number of operating cycles the grille has completed (open/close = 1 cycle). Note: This is already shown by default at the top left corner in the main screen.



Temperature shows the internal temperature of the DGII Controller. This is a raw analog value and does not represent degrees centigrade or Fahrenheit. A display on the bottom graphically approximates either a Low or High temperature



DC Link shows the internal DC Link voltage along with the acceptable range.



INT Levels shows the control's actual internal supply voltages.

### 3. Profile Selection Menu

The profile selection is done at the factory by default. Profiles can be selected based on the grille the controller is operating. The profile is protected by a passcode, and can only be changed by Wayne Dalton service representative. All settings are lost and reverted back to defaults when the profile is changed. Profiles can be accessed through the main menu under Profile Selection.

### 4. Limit Setup Menu

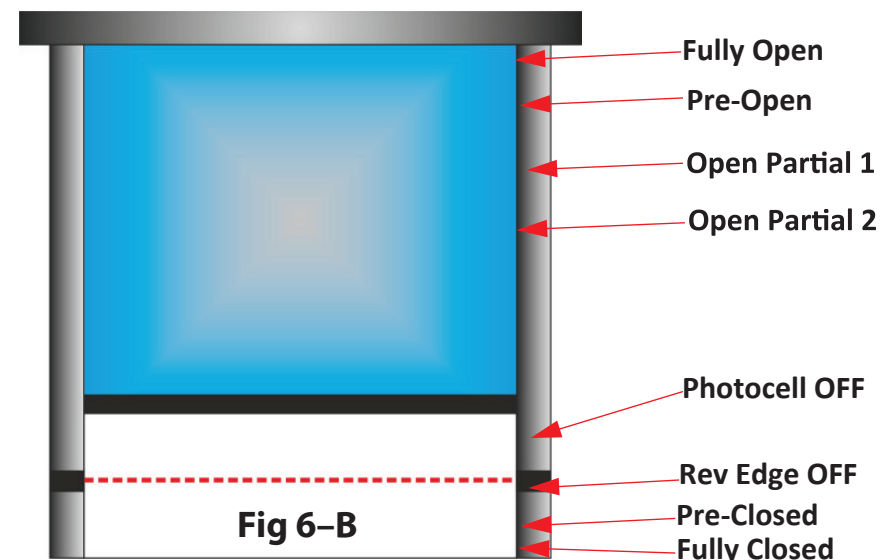
Individual limits can be updated manually, however; the best option is to use the quick setup process as discussed earlier. The grille will not be operational when settings limits. Limit settings are as described:

## ⚠ WARNING

All Entrapment Protection Devices are **OFF** when setting limits. Devices **OFF** while setting Limits include: Edge Contact, Photoeye, Wall push buttons, Radio Control, Limit Sensors, Loop Detector, or any motion sensor used as either an actuator or an Entrapment Protection Device. Only the Interlock remains active. **USE CAUTION! Do NOT use for general grille operation when setting limits.**

To configure the Limit Settings manually after using Quick Setup, select each individual position listed below from the Limit Setup menu, then move the grille to the desired position. Store the position by pressing STOP or ENTER when finished. The display shows Stored and returns to the previous menu.

- Closed: Grille fully closed.
- Pre Closed: Position where grille changes to pre-closing speed during close.
- Pre Open: Position where grille changes to pre-open speed during open.
- Open: Grille fully open.
- Open Part 1: Partially open position 1. Grille opens to this position when a part 1 open input is active. (default: 75% of grille open limit)
- Open Part 2: Partially open position 2. Grille opens to this position when a part 2 open input is active. (default: 50% of grille open limit)
- Rev. Edge OFF: Sets grille position where sensing edge check is turned off: the limit where the reversing sensing edge should be ignored.
- Photocell Off: Sets grille position where photocell should be ignored.





## **5. System Configuration Menu**

This menu contains all editable parameters on the grille system. A passcode is required in order to change the settings. The grille will not operate when inside the menu.

### A. Timers

1. Contains all the same timers in the Express Menu.
2. Setting the timer to 0 disables the timer.

B. Outputs - Configurable relay activation based on custom grille status/events. Table on page 40 lists all available status/events.

C. Inputs - Inputs with configurable actuator functions. Table on page 39 lists all functions available with each input.

D. Position sensor -Do not update/menu is not used

E. Reference -Do not update/menu is not used.

F. Sensing edges -1 or 2 Sensing edge select as well as Sensing edge Type.

G. Photoeyes -Do not update/menu is not used

H. Motor Configuration - Do not update / Engineering use only.

I. Frequencies - Do not update / Tech Services use only.

J. Ramps - Do not update / Tech Services use only.

K. DG-XNET -Do not update / Menu not used.

L. Options -Do not update / Menu not used.

M. System -Do not update / Engineering use only.

## **6. Configuration -Inputs/Outputs**

A. Inputs. There are 3 parameters that can be set. Refer to **FIG 6-C** (close up view of Input relays)

1. Function -A list of functions can be selected to determine how the input should operate the grille.
2. Name -a name can be applied to the specific function
3. Logic -The logic for activation of the grille can be chosen. Either Normally Open (0VDC ->24VDC) or Normally Closed (24VDC ->0VDC).

B. Outputs. Refer to **FIG 6-D** (close up view of Output relays)

- 1 Function -list of functions can be selected to activate the output relay
2. The output is dependent on the input wired into the relay pins 2, 5, 7, 9.
3. Output relays 1 & 2 consist of two relay outputs, a NO and NC. Output Relays 3 &4 contain only NO relay activation.

## MENUS (continued)

INPUT SIGNAL	ACTIVATION DESCRIPTION`
Manual	Momentary activation opens grille unless the grille is already at an open position. In this case, the grille will close. 1) If the Manual timer is set to a value greater than zero, the controller delays closing of the grille until the timer expires.
Open	Opens the grille to fully open position when activated.
Auto 1	Momentary activation opens grille to the fully open position limit. Upon deactivation the controller delays the grille for the duration of the Auto timer. If reactivated during this time delay, the timer will be reset and will begin to decrement when the input is again deactivated. Upon expiration of the timer, the controller closes the grille to fully closed position. If timer is not used, the grille will stay in the open position when activated.
Stop	Momentary activation stops the motion of the grille. This input uses the Stop Deceleration Ramp set under the System Config menu. <b>This input is also used to clear certain error conditions.</b>
Close	Closes the grille to fully open position when activated
Emergency Stop	Activation immediately halts the grille in motion. <b>This input uses the Emergency Deceleration Ramp set under the System Config menu.</b>
Sensing edge	Activation during a closing cycle stops the grille and then reverses the grille motion back to the fully open position limit. An "E10 Sensing edge Activated" error occurs.
Photoeye	Activation during a closing cycle stops the grille and then reverses the grille motion back to the fully open position limit.
Lock Open	Activation causes the controller to hold the grille at the fully open position limit. The input must be continuously activated to maintain the locked open state. Deactivating this input unlocks the grille and allows normal operation.
Lock Close	Activation causes the controller to hold the grille at the fully closed position limit. The input must be continuously activated to maintain the locked open state. Deactivating this input unlocks the grille and allows normal operation.
Open Jog	Activation of this input moves the grille in the direction of the fully open limit at Jog speed. Deactivating this input stops the grille in motion. Activation during closing does not open or stop the grille.
Close Jog	Activation of this input moves the grille in the direction of the fully closed limit at Jog speed. Deactivating this input stops the grille in motion. Activation during opening does not close or stop the grille.
Breakaway	Activation halts grille motion.
Open Position 1	Activation opens the grille to the partial open 1 position limit. If activated during closing, grille will reverse to 1 position limit.
Open Position 2	Activation opens the grille to the partial open 2 position limit. If activated during closing, grille will reverse to 2 position limit.
Open Part 1 Auto	Activation opens the grille to partial open 1 position limit. The controller then delays the grille for the duration of the Auto Timer. Upon expiration of the timer, the grille closes fully.
Open Part 2 Auto	Activation opens the grille to partial open 2 position limit. The controller then delays the grille for the duration of the Auto Timer. Upon expiration of the timer, the grille closes fully.
Flip Flop	Activation reverses the grille operation. If grille is closed, activation opens the grille and vice versa. When grille is closing and activated, the grille reverses and begins opening and vice versa.
Man Part 1	Activation opens the grille to the partial open 1 position limit, if not already at this position. If the grille is already at this position, the grille closes.
Man Part 2	Activation opens the grille to the partial open 2 position limit, if not already at this position. If the grille is already at this position, the grille closes.

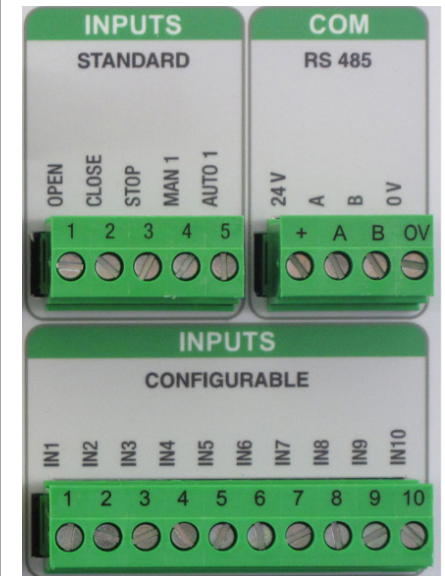
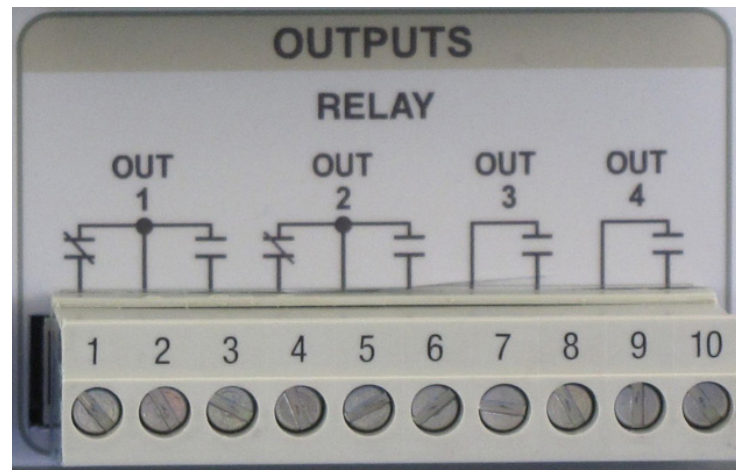


Fig 6-C

## MENUS (continued)

INPUT SIGNAL	ACTIVATION DESCRIPTION
Grille Moving	Output is active when the grille is in motion.
Grille Not Moving	Output is active when the grille is not in motion.
Grille Open	Output is active when the grille is at the fully open position.
Grille Closed	Output is active when the grille is at the fully closed position.
Grille Not Closed	Output is active when the grille is above the fully closed position.
Grille Open Partial	Output is active when the grille is at open part 1 position.
Grille Opening	Output is active when the grille is moving in the open direction.
Grille Closing	Output is active when the grille is moving in the close direction.
Delay to Close	Output is active when the Delay To Close timer is greater than zero and the grille is commanded to close. The output remains active for the duration of the Delay To Close timer.
Delay to Open	Output is active when the Delay To Open timer is greater than zero and the grille is commanded to open. The Open button must remain active until the Delay To Open timer has expired, the output will be active during this time. Upon expiration of the timer, the grille opens and the output is deactivated.
Auto Close Active	Output is active for the duration of the Auto or Man timer during an auto close sequence.
System Error	Output is active when DGII is in any error condition.
Pre Warning Active	Output is active for the duration of the Auto Timer <b>and</b> during any close sequence.
Open Alarm Active	Output is active when Open Alarm Timer is greater then zero.



**Fig 6-D**

# INFORMATION MENU

1. How to use the keypad to retrieve operation events, fault/shutdown messages, and system status

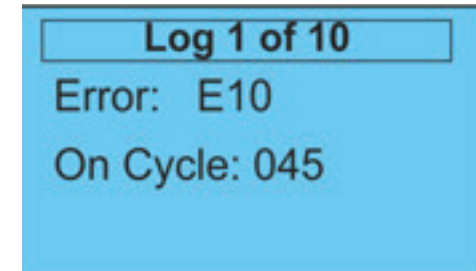
(Also see Section 8—Troubleshooting)

- **With the unit idle**

- Enter the System Status menu.
- Scroll through the list of choices until you reach the Fault Log menu and enter.
- Scroll through the list until you reach the information you're looking for.
- When finished exit the menus and return to the main screen.

**NOTE:** The items in the Fault Log are listed in reverse chronological order with number 1 being the most recent and the highest number being the oldest.

- If NO keys are pressed for 120 seconds, display will exit back to the main menu.
- Motion can occur and panel responds normally to inputs while in the System Status Menus.



## Set Up Check List

### ⚠ CAUTION

Check ALL items below to ensure that the Control Panel is installed and operating properly.

#### CHECK

- The grille operates using all installed control devices.
- The grille runs to its full open and full closed positions.
- The Entrapment Protection Device(s) will reverse a closing grille when activated.
- The proper Actuator selections are made to activate timers.

If the panel is in a location where public access is possible, install a means to limit access to the inside of the panel.

### ⚠ WARNING

To prevent injury, entrapment devices must be tested to insure proper operation.

# Section 7

## Special Grille System Features

### Exterior Hood Installation

**For exterior installations only!**

**NOTE:** If optional Brush Seal was purchased and is not installed at this time, stop and install before continuing.

#### 1. INSTALL EXTERIOR HOOD

- A. Measure locations of motor/gearbox and headplate to ensure Exterior Hood will adequately cover these components.
- B. Attach the motor cover end cap to the hood using rivets. End cap fits **inside** the hood with the mounting flange to the outside, **Fig. 7-A**. Install hood supports (if provided) at this time.
- C. Pre-drill the hood and end cap flanges at 18" spacing for wall mounting screws. Hole diameter is dependant on the size wall fasteners (not provided) used to attach hood to wall.
- D. Place the hood assembly **over** the headplates and motor/gearbox and **against** the wall, **Fig. 7-A**.
- E. Fasten the hood assembly to the wall.
  - Place fasteners using the pre-drilled holes (wall fasteners not included). Hood to wall joint sealant (not provided) is optional.

### CAUTION

Extra care must be taken when installing optional accessories. Optional accessories must be installed in such a way that they do not compromise the weather tightness of electrical components and enclosures.

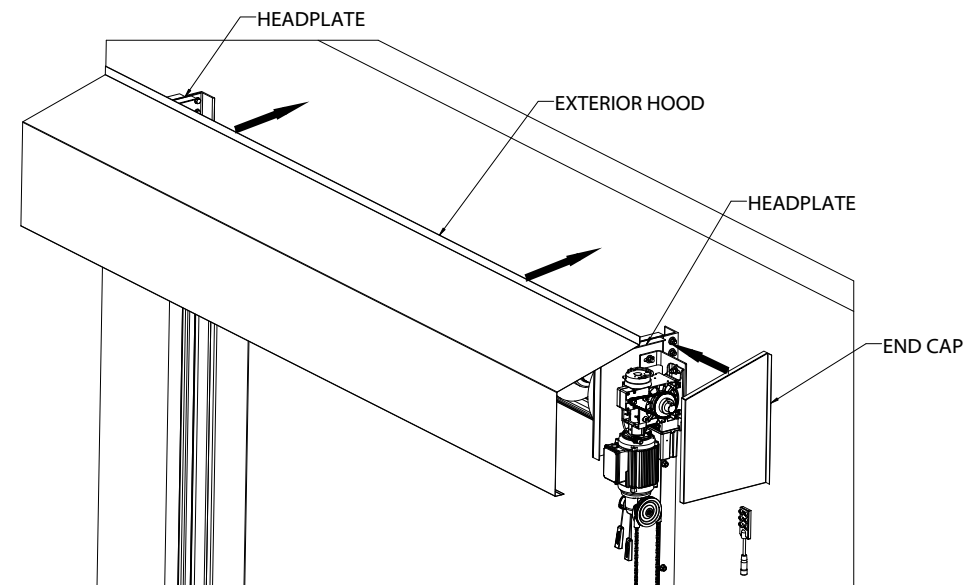


Fig 7-A

#### HOOD SUPPORTS NOT SHOWN

**NOTE:** Install hood supports (if provided) at even intervals across header. Number and placement of hood supports will vary with hood type and width.

# Section 8 (continued)

## Troubleshooting CONTROLLER

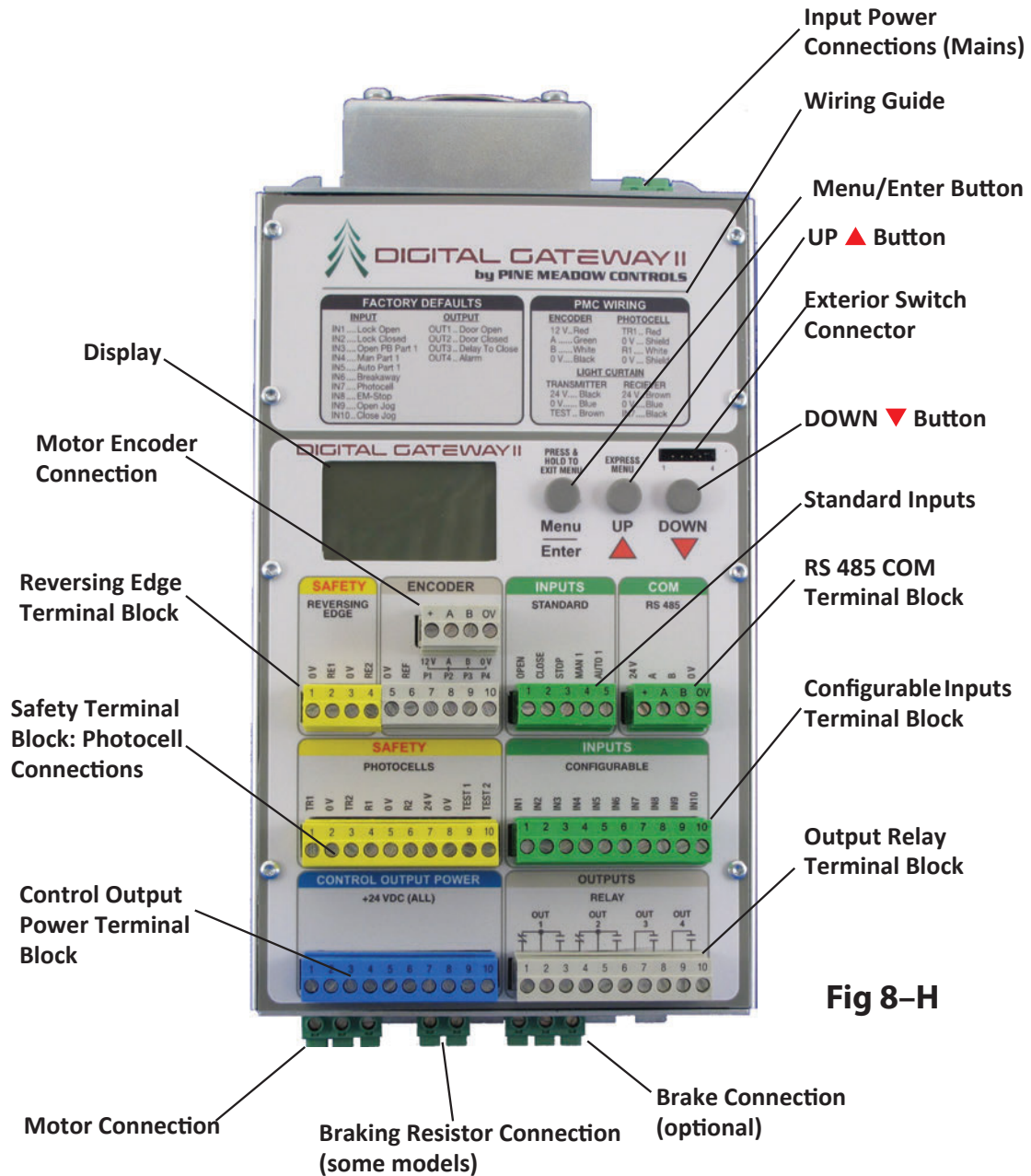


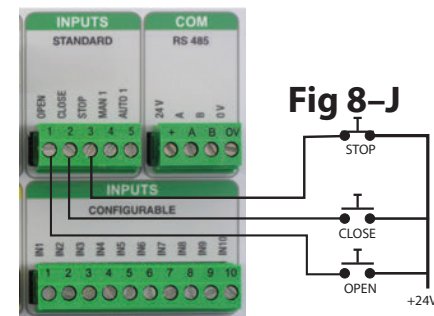
Fig 8-H

# CONTROL PANEL TROUBLESHOOTING

GENERAL		
TROUBLE	POTENTIAL CAUSE	NOTES / CORRECTIVE ACTION
Grille will not move	Grille may be in Shut Down mode. Fix issue.	Press stop key to clear fault.
	No power	Check motor wiring, power line, system rating.
Timed Close not functioning	Timer is set to 0.	Verify or update specific timer in express menu..
	Timer condition not met.	Verify grille is at open close limits, or condition is met.
Auto 1/ Manual 1 Function not working	Wiring or connection loose, signal not reaching controller.	Verify connections.
	Auto 1/Man 1 not selected as function.	Verify chosen input function.
On key release, grille stops or reverses	One of the sensor inputs activated.	Verify sensor inputs.
Timed Close quits after a few reverses	After a factory set number of failed attempts, usually three, the grille will stop attempting to Time Close after a reversal. This is normal grille function.	Grille will reverse a Timed Closed grille without counting the first reversal as a failed attempt. NOTE: If Entrapment Prevention Inputs cause reversals in the meantime, the reversals will continue to count as failed attempts and stop the close timer after three tries.
Wall push button not responding.	Wiring and firmware setting incorrect.	Common should be set to 24V Stop is set to NC in firmware (System config > Inputs) Open is set to NO. Close is set to NO. Refer to <b>Fig 8-J</b> page 46
General service Due: XXXXX	Routine service interval has elapsed.	Contact distributor for required maintenance.
Major service Req'd XXXXX	Required maintenance interval has elapsed.	Contact distributor for required maintenance.
Grille stops for no reason, or acts differently than before - No errors displayed, only shows IDLE at status	A brownout or short has affected the controller	Use the disconnect switch to turn off the power, wait until the unit shuts off, then turn it back on (hard reset). -Contact customer service if it is still an issue.
	Possible overheat	Check fault log
One of the options to the Junction Box does not operate as expected	Connection to the Junction Box is incorrect	Ensure the Junction Box connections are correct (Via Manual) 1. Radio Remote Receiver is wired to OPTION 2 (or to Manual1 input) -A 10 kohm load is also needed to be wired from the Manual1 input to a 24VDC connection (part of the kit when delivered). 2. Loop Detector or Motion Detector is wired to Option 1 (or to an Auto1 input) NOTE* Both can be wired, but one needs to be wired directly to the Control Unit (regular wire can be used)
Quick setup aborted	Fault occurred when setting limits	1. Fix faults in system. 2. Make sure Encoder does not roll over from +32,000 to -32,000 when setting limits. 3. Make sure Position count increases when setting grille to open limit (grille direction incorrect). 4. Restart Quick Setup.

## CONTROL PANEL TROUBLESHOOTING (CONTINUED)

TROUBLE	POTENTIAL CAUSE	NOTES / CORRECTIVE ACTION
Grille limits have shifted	Encoder fault/failure	1. Verify Encoder connections. 2. Verify magnet in encoder has not moved and has not rubbed against the encoder. 3. Reset limits.



## CONTROL PANEL STATUS MESSAGES

MESSAGE DISPLAYED	CAUSE	NOTES / CORRECTIVE ACTION
-----	Displayed if no message code is present in the Event or Error Log.	Contact service representative.
<b>STATUS</b>		
Idle	Grille at rest, not at open, close, mid limits.	Displayed when grille is motionless in Idle and not at open, close, open P1 limits. Grille stopped using the STOP key.
<b>STATUS</b>		
Count down	Grille at rest and counting down to timed close or open.	Time remaining in seconds is displayed.
<b>STATUS - OPENING</b>		
Opening	Grille opening.	Displayed while grille is opening from activation.
<b>STATUS - CLOSING</b>		
Closing	Grille closing.	Displayed while grille is closing from activation.
<b>STATUS - STOP</b>		
Stop	Grille stopping.	Displayed while grille is stopping from activation.
<b>STATUS</b>		
Locked	Incorrect pass code input.	Displayed when the wrong pass code is entered
Closed	Position at close limit.	
Open	Position at open limit.	
Open P1	Position at 75% of open limit.	
Open P2	Position at mid limit.	



## CONTROL PANEL ERROR MESSAGES - INVERTER ERROR CODES

CODE	DESCRIPTION	PROBLEM	POSSIBLE SOLUTION
INV_ERROR_UU	DC Link low (Top Priority)	The incoming mains voltage is too low	View System Status - DC Link to check that the voltage is within the range shown.
INV_ERROR_OU	DC Link high (Medium Priority)	Either the incoming mains voltage is too high or the deceleration rate is too short	View System Status - DC Link to check that the voltage is within the range shown. Decrease the deceleration ramps.
INV_ERROR_OC1	Overcurrent 210% (Low Priority)	The motor current exceeds the inverter rating by 210%	View the Motor Current display to check the current delivered to the motor. Check the motor nameplate data to confirm that the correct controller model is being used. Check for mechanical obstruction or damage.
INV_ERROR_OC2	Overcurrent 150%/30 sec (Low Priority)	The motor current exceeds the inverter rating by 150% for more than 30 seconds	View the Motor Current display to see the current delivered to the motor. Check the motor nameplate data to confirm that the correct controller is being used. Check for mechanical obstruction or damage.
INV_ERROR_OC3	Overcurrent during acceleration	Overcurrent while accelerating	View the Motor Current display to see the current delivered to the motor. Decrease the acceleration ramps
INV_ERROR_OC4	Overcurrent DC/Brake (Medium Priority)	Overcurrent while DC braking	View the Motor Current display to see the current delivered to the motor. Decrease the DC Brake level.
INV_ERROR_OC5	Peak overcurrent (High Priority)	Severe overload	Check for: a short in the motor cable stalled motor mechanically or electrically damaged motor. If equipped with a parking brake, ensure that it is being released. Decrease the Boost parameters.
INV_ERROR_OH	Controller overheat (High Priority)	The inverter is overheated	View System Status - Temperature to check that the reported temperature is within range. Check ventilation and ensure fan, if present, is operating. Reset the controller and confirm that the fan operates for 1 second during the power-up routine. Reduce the duty cycle of the grille.
INV_ERROR_12V	Low internal 12v (Top Priority)	The internal 12V DC power supply voltage is too low	View the System Status - Int Levels to check that the voltage is within range. Check I/O wiring for shorts.
INV_ERROR_24V	Low internal 24v (Top Priority)	The internal 24V DC power supply voltage is too low	View the System Status - Int Levels to check that the voltage is within range. Check I/O wiring for shorts.

## CONTROL PANEL ERROR MESSAGES - GRILLE CONTROL ERROR CODES

CODE	DESCRIPTION	PROBLEM	POSSIBLE SOLUTION
E01	Slip error (Low Priority)	Mechanical overload (Slip Monitoring) or missing signal from encoder.	Check grille for obstruction. Ensure the pulse output from the encoder is connected to terminal P2 on the controller. Verify that the encoder pulse output is set correctly.
E02	Direction Error - occurs during setup only (Low Priority)	The direction of the motor is incorrect. The encoder count must increment positively while the grille is moving in the open direction.	Use the Motor Direction parameter to set the correct direction for the motor and encoder.
E03	No Signal From Pulse Generator - occurs during setup only. (Low Priority)	No pulse input detected from the encoder.	Check grille for obstruction. Ensure the pulse output from the encoder is connected to terminal P2 on the Controller. Verify that the encoder pulse output is set correctly.
E04	Speed Error	Grille moves faster/slower than Expected	Check grille for obstruction.
E05	N/A		
E06	N/A		
E07	Run Timer Exceeded (Low Priority)	The Run Timer has expired.	Check the Run Timer parameter to ensure a correct value.
E08	Sensing edge Test Fail (Medium Priority)	The Sensing Edge test has failed	Check the connections from the reversing edge to the controller. If using the Seywave wireless system, check operation of connected host and remote grille sensor.
E09	Sensing edge Connection (Medium Priority)	The Sensing Edge connection cannot be verified.	Check the connections from the reversing edge to the controller. If using the Seywave wireless system, check operation of connected host and remote grille sensor. Verify Sensing edge is not activated.
E10	Sensing edge 1 Activated (Low Priority)	The Sensing Edge has been activated	Check for obstruction in grille's path.
E11	Sensing edge 2 Activated (Low Priority)	The Sensing Edge has been activated	Check for obstruction in grille's path.
E12	Lifting Force Exceeded (Low Priority)	The torque limit has been exceeded	If the torque limiting feature is being used, adjust the Torque Limit parameter to suit the application.
E13	No Encoder movement	Encoder did not move when expected	Check for obstruction. Check connection from Encoder to Motor.
E14	Absolute Encoder Comm Loss (Top Priority)	Communication with the absolute encoder has been lost.	Check the connections between the encoder and the controller.
E15	Installation Fault (Low Priority)	An error occurred during Quick Setup	Re-perform Quick Setup
E16	Encoder fault	Encoder communication is not correct	Check Encoder. Verify connections.

## CONTROL PANEL ERROR MESSAGES - GRILLE CONTROL ERROR CODES

CODE	DESCRIPTION	PROBLEM	POSSIBLE SOLUTION
E17	Reset Limits (HIGH PRIORITY)	The position limits cannot be verified	Perform a Quick Setup
E18	Wireless Airlock Failed to Authorize Opening (Low Priority)	The controller failed to receive an Airlock request acknowledgement.	Check opposite controller to ensure that it is operational. Check that both controllers have been wirelessly connected together and that each controller has Wireless and Airlock enabled. Disconnect controllers and run a discovery to reconnect controllers.
E19	Wireless No Response	There was no response from the onboard wireless	Ensure that the Wireless is Enabled then power cycle the controller.
E20	Backroll error	Grille movement when at idle state	Verify there are no obstructions, verify motor gear box is functional.
E21	Option - Seywave OCS Remote Timeout	A paired Seywave wireless O/C/S remote has timed out.	Check the remote for operation. Refer to supplied Seywave Wireless manual for troubleshooting.
E22	Option - Seywave DS Remote Timeout	A paired Seywave wireless Grille Sensor remote has timed out.	Check the remote for operation. Refer to supplied Seywave Wireless manual for troubleshooting.
E23	Option - Seywave DS Connection Fault	A paired Seywave wireless Grille Sensor remote has reported a connection fault.	Check the connection and remote for operation. Refer to supplied Seywave Wireless manual for troubleshooting.
E24	N/A		
E25	Manual Crank input active (Medium Priority)	Chain hoist is engaged.	Disengage chain hoist.
E26	Overtravel error (HIGH PRIORITY)	Grille moves beyond limits.	Reset limits
E27	Photoeye connection test fail (Medium Priority)	Monitored Photoeye connection test failed.	Check photoeye connections
E28	Photoeye 1 activation (Low Priority)	Photoeye 1 has detected an obstruction.	Check for obstructions in photoeye path
E29	Photoeye 2 activation (Low Priority)	Photoeye 2 has detected an obstruction	Check for obstructions in photoeye path
E30	Input Timer Exceeded	Input activation lasting longer than 2 minutes.	Verify wall buttons are not stuck. Check connections for a short.

## CONTROL PANEL ERROR MESSAGES - ERROR CODE PRIORITY LEVELS

Priority Level	Reset Condition	Comment
Low	Activation input	Can also be reset by higher priority reset conditions
Medium	Stop, E-Stop or Menu/Enter button pressed	Can also be reset by higher priority reset conditions
High	Menu/Enter button pressed and held for 2 seconds.	Screen Flashes
Priority Reset Limits	Successful Quick Setup	Auto-clears when limits are set
Priority Encoder Connection	Communication restored between encoder and controller	Auto-clears when fault no longer exists
Priority INV_ERROR_UU	Incoming main voltage is within range	Auto-clears when fault no longer exists
Priority INV_ERROR_12VInternal 12V	Internal 12V DC level is within range	Auto-clears when fault no longer exists
Priority INV_ERROR_24V	Internal 24V DC level is within range	Auto-clears when fault no longer exists

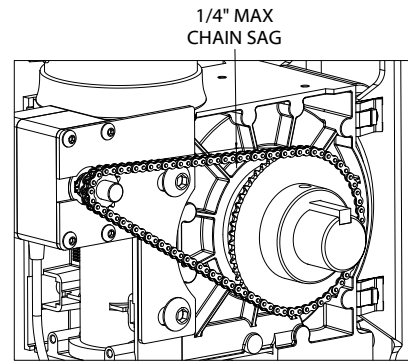
# Section 9

## Service and Maintenance

INSTALLATION DATE: \_\_\_\_\_ INSTALLER INITIAL: \_\_\_\_\_  
 SERVICE ITEM SERVICE INTERVAL (frequency)

SERVICE ITEM	SERVICE INTERVAL (frequency)		
	EVERY DAY	EVERY 6 MOS. OF 50,000 CYCLES	EVERY 12 MOS. OF 100,000 CYCLES
General Inspection		•	
Limit Switch Chain Tension and Alignment		•	
Manual Operation of Door		•	
Sensing Edge & Photo Eye systems	•		
Mounting Bolt Tightness			•
Motor Brake Gap and Motor			•
Check Limit Position		•	
Check Emergency Brake Activation List		•	

**Table 9-A**



**FIG 9-B**

**Table 9-A provides a schedule of Service and Maintenance items.**

Below is a list of service and maintenance highlights.

### CAUTION

Failure to perform specified service and maintenance may result in an unsafe condition, will void limited warranty, and may result in premature failure of the unit. Service and Maintenance are necessary to ensure safe operation of the Model 600 ADV grille.

#### Service Interval Message

- When cycles indicate service is required, the panel will display which service interval has been reached.
- Once service is completed, clear the service message by going into System Configuration ->System -> Clear Service

#### Maintenance Interval Message

- Upon reaching 280,000 grille cycles (580,000 & 880,000, etc.), the panel will display which maintenance interval has been reached.
- Contact your distributor to have required maintenance performed.
- Once service is completed, clear the service message by going into System Configuration ->System -> Clear Service.

#### General Inspection

- Visually inspect wiring conduit and cables.
- Inspect fixtures such as: Bearings, conduit boxes, hood, gear box (for oil leakage), motor.
- Inspect safety labels, placement and condition.
- Lubricate guides with paste wax or silicone spray.

#### Encoder Chain Tension and Alignment

- Check sprocket alignment.
- Check chain tension, max sag is 1/2"; **Fig. 9-B**.
- Lubricate chain.

#### Manual Operation of Grille

- Inspect grille alignment and level.
- Inspect slats and endlocks for damage.
- Inspect guides, Sensing edge and hood for damage.

#### Mounting Bolt Tightness

- Check fasteners anchoring headplates and grille guides to wall.

#### Sensing edge & Photoeye systems

- Test Sensing edge activation daily.
  - Place a solid object, higher than 12", on floor and close grille. Sensing edge should reverse grille direction on contact with object.
- Test Photoeye activation daily.
  - Obstruct the Photoeye beam with a solid object. Photoeye should reverse grille direction.

#### Motor Brake Gap and Motor

- Observe and listen to motor and gearbox in operation.
- Check fasteners anchoring motor bearing, motor, gearbox for tightness.
- See Brake Gap Inspection and Adjustment on next page.

#### Check Limit Position

- Verify the grille stops at correct open position.
- Verify that grille closes fully without excessive "stacking" of curtain in guides.
- Verify approach speeds provide for smooth starts and stops.

#### Check Drop Stop Device

- If the Drop Stop Device has been activated replace the Drop Stop Device.

**Keep records of all service and maintenance.**

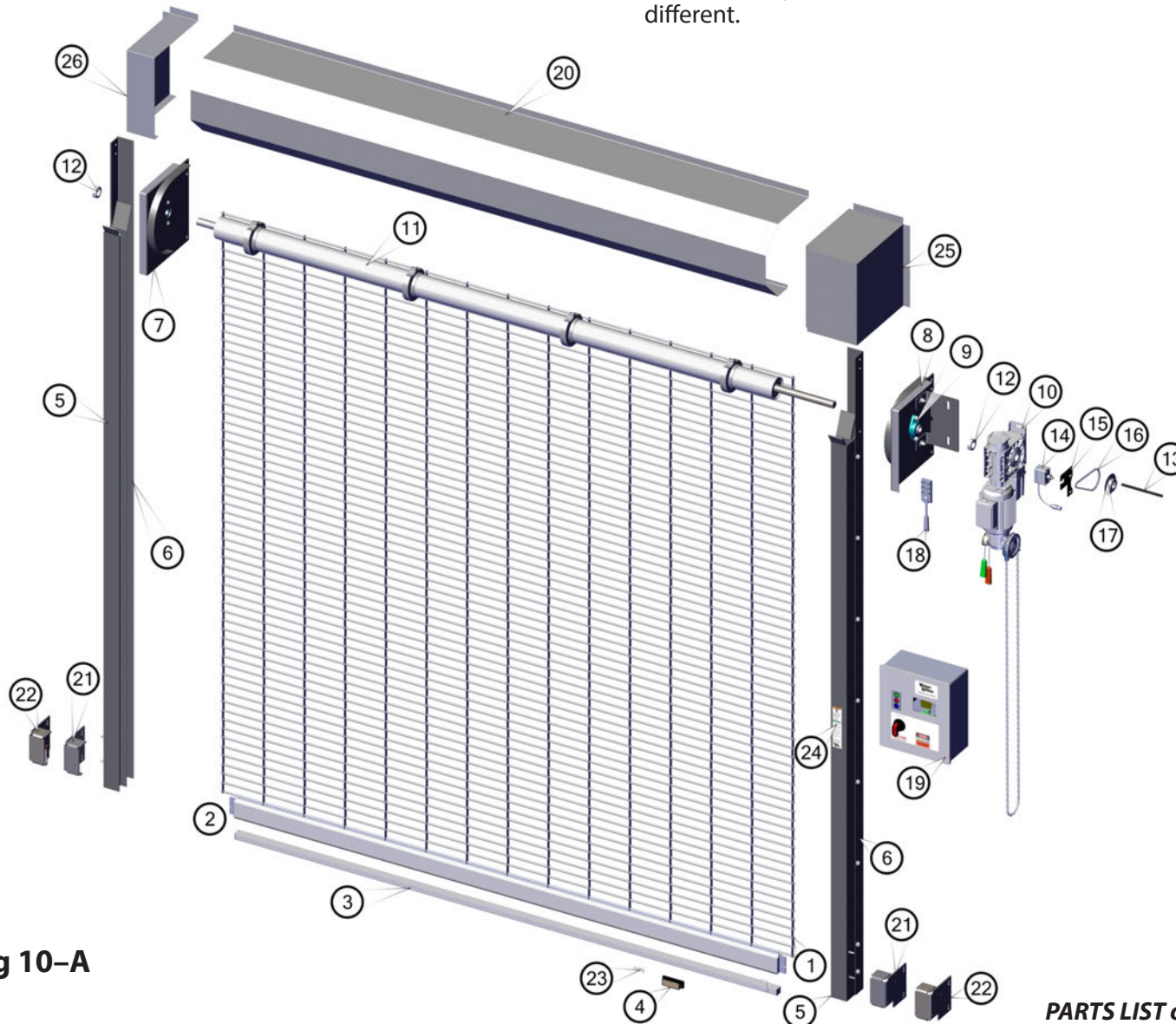
# Section 10

## Illustrated Parts Breakdown

### Parts Drawing

**NOTE:** Fasteners and some parts not shown for clarity.

**NOTE:** Components and component locations are shown here for reference only. Your unit installation and component locations may be different.



**Fig 10-A**

**PARTS LIST on next page**

## Illustrated Parts Breakdown *(continued)*

### Table of Part Numbers

BEFORE ORDERING PARTS LOCATE YOUR ORIGINAL DOOR NUMBER FOUND ON THE NAMEPLATE ATTACHED TO YOUR BOTTOM BAR							
ITEM	DESCRIPTION	PART NUMBER	BUILT TO ORDER	ITEM	DESCRIPTION	PART NUMBER	BUILT TO ORDER
1	COMPLETE GRILLE ASSY.	INQUIRE	YES	18	JUNCTION BOX	308694	NO
2	COMPLETE BOTTOM BAR ASSY.	307678	YES	19	CONTROL PANEL	308695	NO
3	>SENSING EDGE CONDUIT BOX	608268	NO	20	HOOD ASSY.	307582	YES
4	>SENSING EDGE COVER	408256	YES		>HOOD LOGO (NOT SHOWN)		NO
5	GUIDE ASSEMBLY	308156	YES	21	PHOTOEYE ASSY. PAIR (RETROREFLECTIVE)	810187	NO
6	HI-USE POLYURETHANE WEAR STRIP	607116	YES		>REFLECTOR, RETROREFLECTIVE SENSOR	500374	NO
	>GUIDE WEATHERSTRIP, BLADE TYPE (NOT SHOWN)	086695	YES		>BRACKET, SENSOR	500375	NO
	>WEATHERSTRIP RETAINER, ALUMINUM (NOT SHOWN)	086620	YES		>RETROREFLECTIVE SENSOR	500376	NO
7	HEADPLATE ASSY., NON-DRIVE	810264	NO		>BRACKET	810188	NO
8	HEADPLATE ASSY., DRIVE	810264	NO		>PHOTOEYE CABLE (NOT SHOWN)	308697	YES
9	FLANGE BEARING	600261	NO	22	PHOTOEYE ASSY. PAIR (OPTIONAL THRUBEAM)	810187	NO
10	GFA MOTOR UNIT	INQUIRE	NO		>PHOTOEYE TRANSMITTER	107322-0005	NO
11	BARRAL ASSY.	810168	YES		>PHOTOEYE RECEIVER	107322-0005	NO
12	SET COLLAR	604297-1125	NO		>PHOTOEYE CABLE (NOT SHOWN)	308697	YES
13	KEY .375 X .375 X 9"	082090	NO		EXTERIOR HOOD ASSY. (OPTIONAL) (NOT SHOWN)	810213	YES
14	ENCODER ASSY.	810235	NO	23	SENSING EDGE WARNING LABEL	607873	NO
15	ENCODER	824811	NO	24	SAFETY LABEL	800372	NO
16	CHAIN #25	086565	NO	25	MOTOR COVER	810252	NO
	ENCODER CABLE ASSY. (NOT SHOWN)	308696	YES	26	NON-DRIVE END COVER	810212	NO
17	LIMIT DRIVE SPROCKET	810182	NO				

Table 10-B



## Rolling Grille Model 600 ADV Advanced Door System Option Limited Warranty

Wayne Dalton, a division of Overhead Door Corporation ("Seller") warrants to the original purchaser of the Model 600 Rolling Grille with Advanced Door System Option ("Product"), subject to all of the terms and conditions hereof, that the Product and all components thereof will be free from defects in materials and workmanship for the following period(s) of time, measured from the date of installation:

- **MOTOR – Seller warrants the motor for a period of 60 MONTHS.**
- **COMPONENTS – Seller warrants all mechanical door system components and the control panel hardware for a period of 24 MONTHS or 300,000 cycles\*, whichever occurs first.**

Seller's obligation under this warranty is specifically limited to repairing or replacing, at its option, any part which is determined by Seller to be defective during the applicable warranty period. Any labor charges are excluded and will be the responsibility of the purchaser.

This warranty is made to the original purchaser of the Product only, and is not transferable or assignable. This warranty does not apply to any unauthorized alteration or repair of the Product, or to any Product or component which has been damaged or deteriorated due to misuse, neglect, accident, failure to provide necessary maintenance, normal wear and tear, or acts of God or any other cause beyond the reasonable control of Seller. This warranty does not apply to any damage or deterioration caused by door curtain rubbing together as the door rolls up upon itself or caused by exposure to salt water, chemical fumes or other corrosive or aggressive environments, whether naturally occurring or man-made, including, but not limited to, environments with a high degree of humidity, sand, dirt or grease. Wearing away of the painted surfaces of the Product is a common occurrence resulting from the curtain repeatedly coiling upon itself and uncoiling during normal usage (See DASMA #274), and is specifically excluded from this warranty. Seller does not warrant that the Product software will provide error-free operation or be free from defects.

**THIS WARRANTY IS EXCLUSIVE AND IN LIEU OF ANY OTHER WARRANTIES, EITHER EXPRESS OR IMPLIED, INCLUDING BUT NOT LIMITED TO ANY IMPLIED WARRANTY OF MERCHANTABILITY OR FITNESS FOR A PARTICULAR PURPOSE.**

**IN NO EVENT SHALL SELLER BE RESPONSIBLE FOR, OR LIABLE TO ANYONE FOR, SPECIAL, INDIRECT, COLLATERAL, PUNITIVE, INCIDENTAL OR CONSEQUENTIAL DAMAGES, even if Seller has been advised of the possibility of such damages. Such excluded damages include, but are not limited to, loss of use, cost of any substitute product, or other similar indirect financial loss.**

Claims under this warranty must be made promptly after discovery, within the applicable warranty period, and in writing to the authorized dealer or installer whose name and address appear below. The purchaser must allow Seller a reasonable opportunity to inspect any Product claimed to be defective prior to removal or any alteration of its condition. Proof of the purchase and/or installation date, and identification as the original purchaser, may be required.

Door Type: \_\_\_\_\_  
Customer Name (Original Purchaser): \_\_\_\_\_  
Customer Installation Location: \_\_\_\_\_  
Order # \_\_\_\_\_ Date of Installation: \_\_\_\_\_  
Name of Dealer/Installer: \_\_\_\_\_  
Signature of Dealer/Installer: \_\_\_\_\_

Rev. 06.2012