

# INSTALLATION INSTRUCTIONS FOR FIRESTAR® ROLLING STEEL FIRE SHUTTER MODELS 540 AND 550 ROLL-UP DOORS, WITH SIDE MOUNT OPERATOR

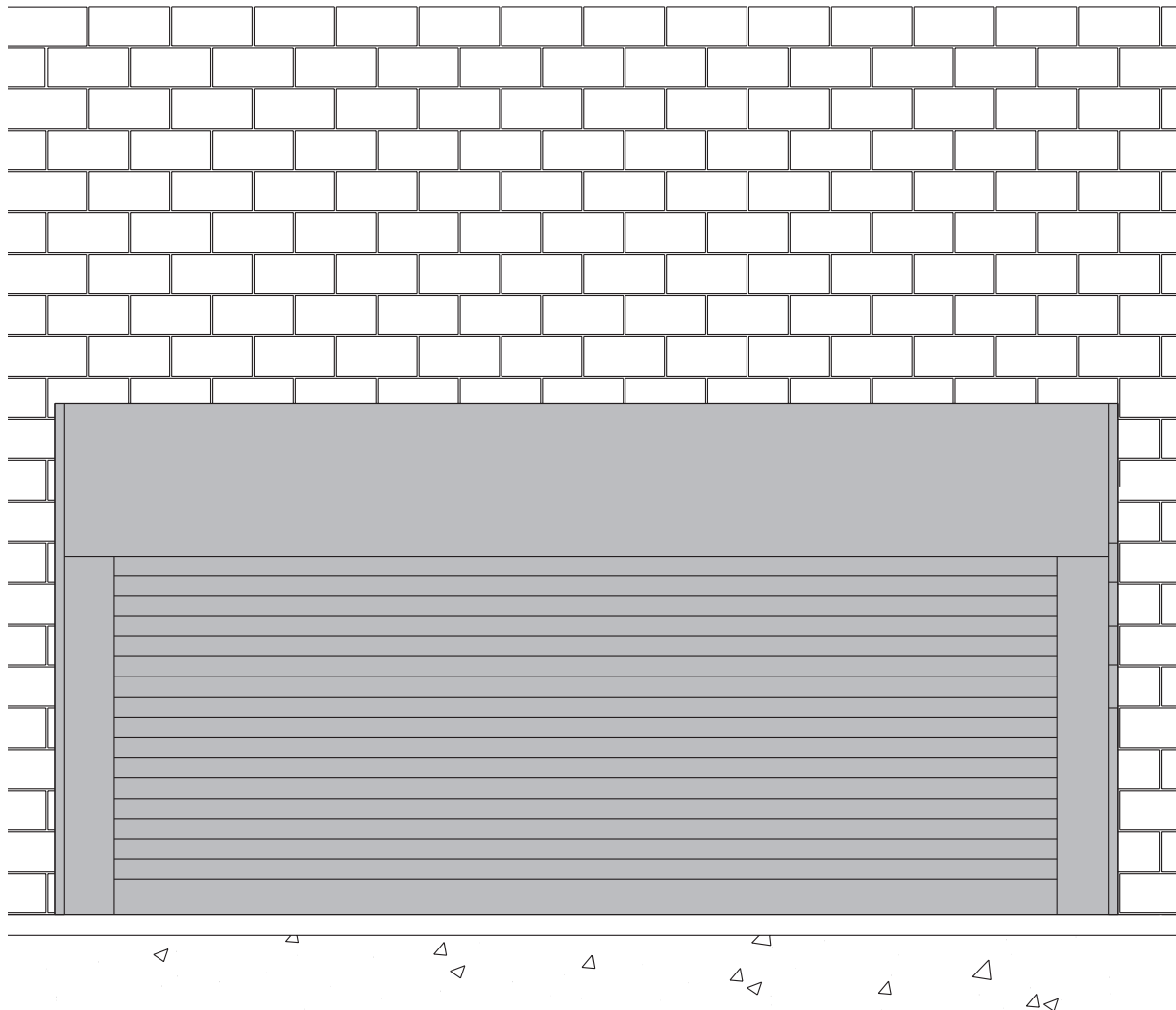


**This installation manual provides the trained door technician information required to install this shutter.**

**READ COMPLETE INSTRUCTIONS CAREFULLY BEFORE ATTEMPTING TO REMOVE EXISTING SHUTTER OR INSTALLING THIS SHUTTER.**  
**PAY CLOSE ATTENTION TO ALL WARNING LABELS AND THE IMPORTANT SAFETY NOTICES ON THE FOLLOWING PAGE.**  
**THIS MANUAL MUST BE ATTACHED TO THE WALL IN CLOSE PROXIMITY TO THE SHUTTER.**

**This manual is intended ONLY for professional use by a trained door systems technician. All others please refer to the end user manual provided to you.**

**Product may be covered by one or more patents. See [www.wayne-dalton.com/patents](http://www.wayne-dalton.com/patents) for details.**





<b>TABLE OF CONTENTS</b>		
<b>SECTION</b>	<b>CONTENTS</b>	<b>PAGES</b>
1	SAFETY INFORMATION	3-4
2	INTRODUCTION	5
3	SUPPLIED PARTS LIST	6-8
4	TYPICAL JAMB TYPES	8
5	DOOR INSTALLATION	9-28
APPENDIX A	APPENDIX A - OPTIONAL COMPONENTS	29
APPENDIX B	SERVICE RECORD	30
APPENDIX C	TROUBLESHOOTING	31
APPENDIX D	ADDITIONAL FUSIBLE LINK CABLING	32-33
APPENDIX E	DROP TESTS AND ANNUAL INSPECTION	34
	WARRANTY	35

# SECTION 1 - SAFETY INFORMATION

## IMPORTANT SAFETY INSTRUCTIONS

### ⚠ WARNING

ROLLING FIRE DOORS ARE LARGE, HEAVY OBJECTS THAT MOVE WITH THE HELP OF ELECTRIC MOTORS. SINCE MOVING OBJECTS AND ELECTRIC MOTORS CAN CAUSE INJURIES, YOUR SAFETY AND THE SAFETY OF OTHERS DEPENDS ON YOU READING THE INFORMATION IN THIS MANUAL. IF YOU HAVE ANY QUESTIONS OR DO NOT UNDERSTAND THE INFORMATION PRESENTED, YOU SHOULD CONSULT A LICENSED PROFESSIONAL OR CALL TECHNICAL SUPPORT AT 1-800-764-1457.

#### DEFINITION OF KEY WORDS USED IN THIS MANUAL:

**⚠ DANGER** INDICATES A HAZARDOUS SITUATION THAT, IF NOT AVOIDED, WILL RESULT IN DEATH OR SERIOUS INJURY.

**⚠ WARNING** INDICATES A HAZARDOUS SITUATION THAT, IF NOT AVOIDED, COULD RESULT IN DEATH OR SERIOUS INJURY.




**⚠ CAUTION** INDICATES A HAZARDOUS SITUATION THAT, IF NOT AVOIDED, COULD RESULT IN MINOR OR MODERATE INJURY.

#### **NOTICE**

INDICATES INFORMATION CONSIDERED IMPORTANT, THAT IT IS NOT RELATED TO INJURY, BUT MAY RESULT IN PROPERTY DAMAGE.

**IMPORTANT:** Required key step for proper door operation.

**NOTE:** Information only.

Potential Hazard	Effect	Prevention
 MOVING DOOR	<b>⚠ WARNING</b> COULD RESULT IN DEATH OR SERIOUS INJURY	Keep people clear of opening while Door is moving. Do <b>NOT</b> allow children to play with the Door Operator. Do <b>NOT</b> operate a Door that jams or one that has a broken spring.
 ELECTRICAL SHOCK	<b>⚠ WARNING</b> COULD RESULT IN DEATH OR SERIOUS INJURY	Turn <b>OFF</b> electrical power before wiring switch and door operator to supply.
 HIGH SPRING TENSION	<b>⚠ WARNING</b> COULD RESULT IN DEATH OR SERIOUS INJURY	Do <b>NOT</b> try to remove, install, repair or adjust springs or anything to which door spring parts are fastened, such as, wood blocks, steel brackets, cables or other like items. Installations, repairs and adjustments must be done by a trained door system technician using proper tools and instructions.

# IMPORTANT SAFETY INSTRUCTIONS CONTINUED...

## 1. READ AND FOLLOW ALL INSTALLATION INSTRUCTIONS.

2. Wear protective gloves during installation to avoid possible cuts from sharp metal edges.

3. Installation MUST comply fully with ALL provisions of NFPA 80 regulations and final approval must be obtained from the authority having jurisdiction. This is the installer's responsibility.

4. Operate the door ONLY when it is properly adjusted and free of all obstructions.

5. The door is constantly under EXTREME SPRING TENSION. DO NOT attempt any adjustments, repairs, alterations or removal of any part of this door, ESPECIALLY TO SPRINGS OR PARTS UNDER SPRING TENSION. Such work must ONLY be performed by a trained rolling fire door systems technician.

6. **DO NOT** allow children to play near the shutter. Children could get caught between the shutter and the floor or counter top, causing severe or fatal injury.

7. To avoid possible severe or fatal injury, **DO NOT** stand in the open doorway or walk through the doorway while the shutter is moving.

8. Should the shutter become difficult to operate or completely inoperative, trained rolling fire door systems technician should be contacted to correct the problem to prevent possible injuries or door damage.

9. Visually check all bolted connections monthly to insure they are secure. Adjustments or repairs must ONLY be performed by a trained rolling fire door systems technician.

10. To prevent injuries, never place hands or fingers between curtain & guides while door is moving.

11. If the building design and door installation create potential pinch points to users, owner is responsible for the installation of appropriate guarding, in compliance with OSHA regulations.

12. This manual is **NOT** intended to provide "take-down" instructions for existing door. Consult your local Wayne Dalton™ dealer if existing door needs to be removed.

13. Thoroughly familiarize yourself with the construction codes in your region before initiating work.

14. Wear proper protective safety gear at all times when installing, repairing and/or adjusting doors.

15. Use a multi-person crew for installing, adjusting and/or repairing larger shutters.

## SECTION 2 - INTRODUCTION

This manual's main function is to assist the installer in correctly mounting shutters with due regard for safety, operation, and sound construction practices. NFPA 80 and local fire and building codes take precedence with regard to any discrepancies among them.

All Wayne Dalton™ FireStar® Rolling Fire Shutters follow the general guidelines set forth herein. Additional installation information for each shutter shipped is found in the packing slip and supplementary drawings. There are also bolt and small parts bags sealed separately with accessory lists describing which parts are to be installed.

### PREPARATION

Read the installation instructions to become familiar with the names of the various components and their relation to each other. It is a necessity for the installer to determine the following:

- The type of mounting (above lintel or under lintel).
- Method of operation (crank, motor, tube motor, or push-up).
- The hand of operation determined from the coil side (right or left).
- Type of jamb on which the shutter guides mount and the fasteners required.
- The dimensions for the opening width, opening height, head room, and side room.

### MATERIAL

Inspect your shutter prior to leaving for job site for possible damage or shortage of parts. Report any claims or shortages to your door supplier immediately.

### CLEARANCES

The installation drawings supplied in the hardware bag contain information on bracket size and head and side room for each shutter. Be sure that the dimensions are correct for the opening you are working on. Take special note of the "C" dimension (**Figure 4, p9**). THIS DIMENSION MUST BE AS SPECIFIED IN ORDER TO PREVENT INTERFERENCE WITH THE PROPER OPERATION OF THE SHUTTER WHILE BEING CLOSED. Measure and verify the required clearances shown on page 8 are available prior to installation.

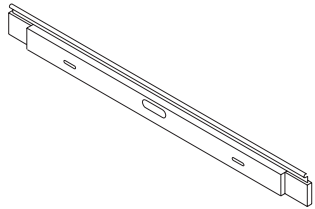
REQUIRED TOOLS		
Electric drill with 3/8" or 1/2" chuck	Cable cutters and diagonal cutters	Level and String level
Masonry drill or impact hammer and bits	Screwdrivers	Chalk line
Chain hoist and sling	Hammer	Plumb line
Ladders and scaffolding	Center punch	Vice grips or C-Clamps
Wrenches	Tape measure	Leather gloves
Two hardened steel bars, 1/2" dia. and approx. 18" long.	Step Ladder	Safety glasses

## WARNING

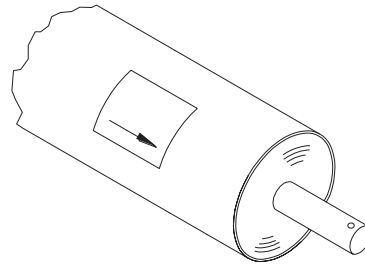
**A POWER SPRING RELEASING ITS ENERGY SUDDENLY, COULD RESULT IN DEATH OR SERIOUS INJURY. TO AVOID INJURY, HAVE A TRAINED DOOR SYSTEMS TECHNICIAN, USING PROPER TOOLS AND INSTRUCTIONS, RELEASE THE SPRING TENSION.**

# SECTION 3 - SUPPLIED PARTS LIST

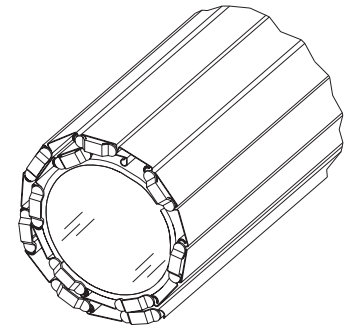
## MAJOR COMPONENTS AND ASSEMBLIES



**BOTTOM BAR ASSEMBLY**



**BARREL ASSEMBLY**



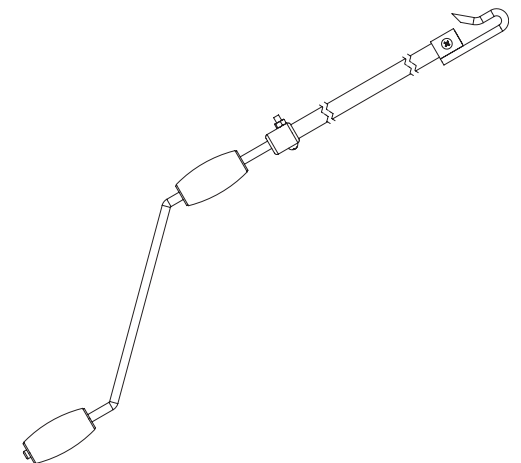
**CURTAIN ASSEMBLY**



**FACE MOUNTED GUIDE**



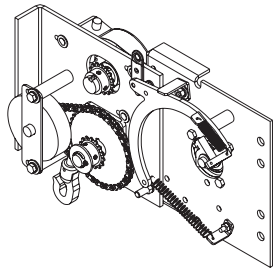
**BETWEEN JAMBS GUIDE**



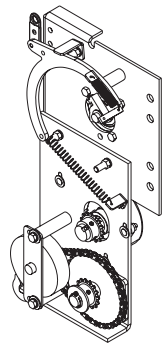
**AWNING CRANK WINDING SHAFT**

# SECTION 3 - SUPPLIED PARTS LIST CONTINUED...

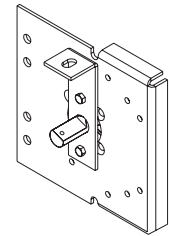
## BRACKET ASSEMBLIES AND COMPONENTS



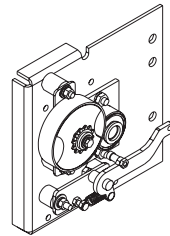
**LIFTUP/CRANK TOP MOUNT OPERATOR BRACKET ASSEMBLY**



**LIFTUP/CRANK BOTTOM MOUNT OPERATOR BRACKET ASSEMBLY**



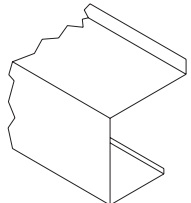
**ADJUSTING BRACKET ASSEMBLY**



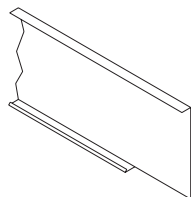
**TUBE MOTOR OPERATOR BRACKET ASSEMBLY**



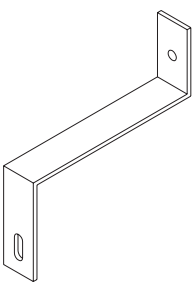
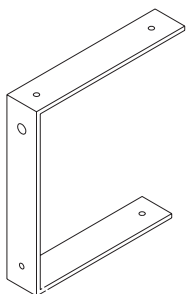
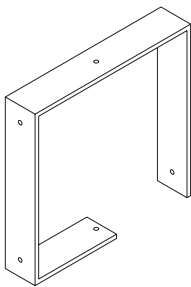
**ADJUSTING WHEEL**



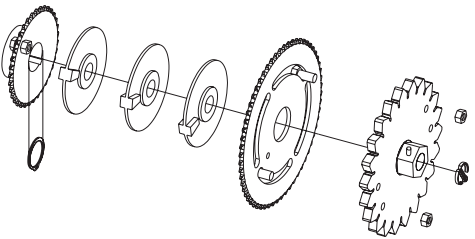
**FRONT HOOD**



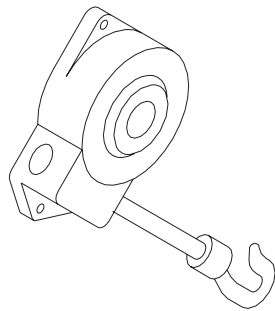
**BACK HOOD**



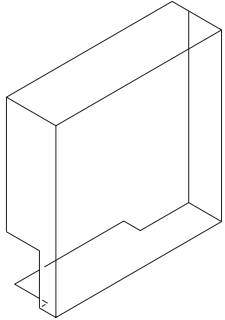
**HOOD STRAPS**



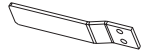
**LIFTUP/CRANK DROP MECHANISM COMPONENTS**



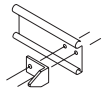
**OPTIONAL AWNING CRANK**



**BRACKET HOUSING**



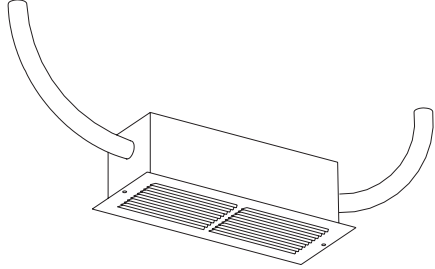
**BOTTOM BAR STOP**



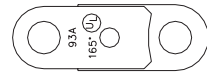
**CURTAIN LOCK**

# SECTION 3 - SUPPLIED PARTS LIST CONTINUED...

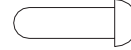
## BRACKET ASSEMBLIES AND COMPONENTS



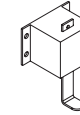
**OPTIONAL FUSE LINK HOUSING**



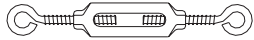
**FUSIBLE LINK**



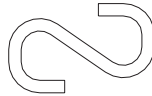
**AW PIN**



**TEST HANDLE**



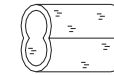
**TURNBUCKLE**



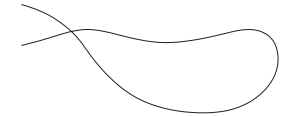
**"S" HOOK**



**COTTER PIN**

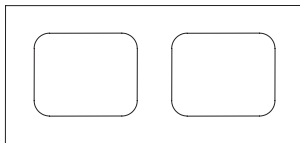


**NICO PRESS FITTING**

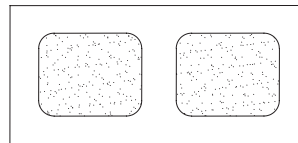


**FUSE CABLE**

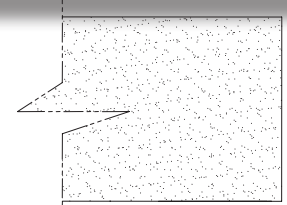
# SECTION 4 - TYPICAL JAMB TYPES



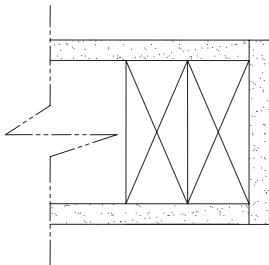
**MASONRY  
(THROUGH BOLTS REQUIRED)**



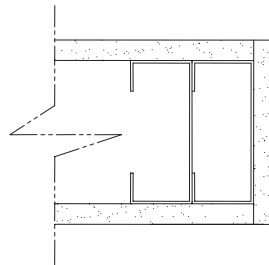
**MASONRY  
(CONCRETE FILLED)**



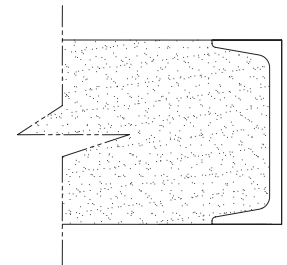
**BRICK OR  
CONCRETE**



**DRYWALL OVER  
WOOD STUD**



**DRYWALL OVER  
STEEL STUD**



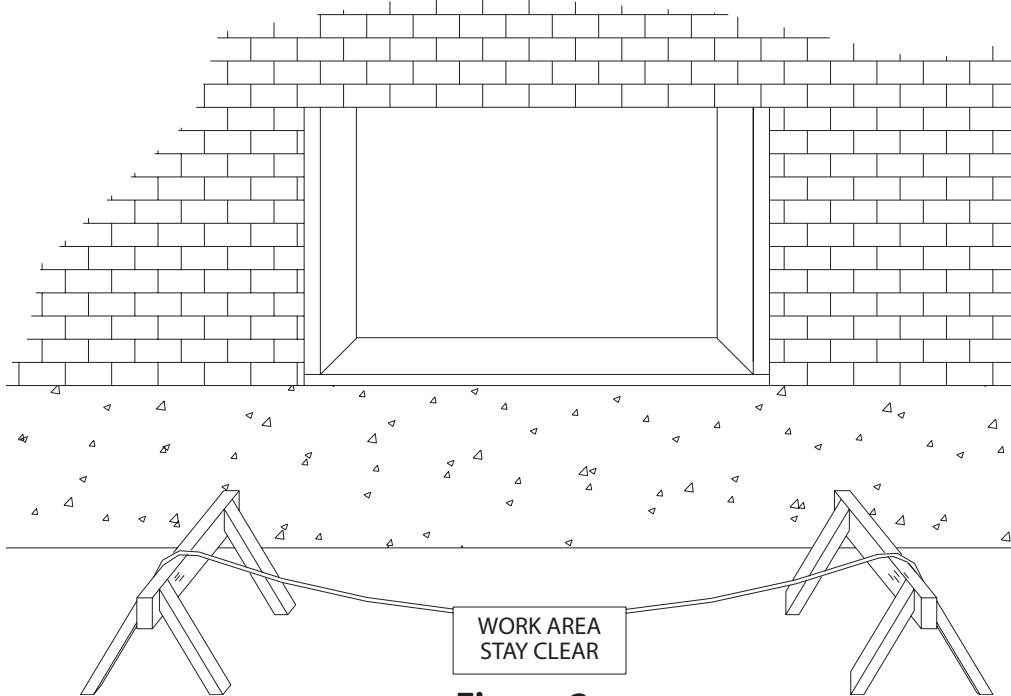
**STEEL  
CHANNEL**

# SECTION 5 - DOOR INSTALLATION

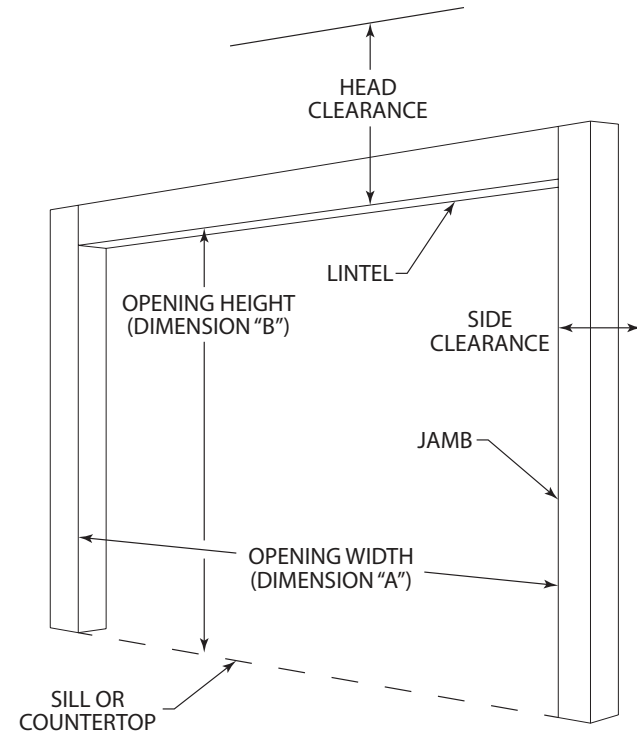
## STEP 1 OPENING CHECKS

Refer to **Figure 1**. Check the opening width "A" and the opening height "B" or "F" and compare with the installation drawing to be sure the opening is the proper size for the shutter. Verify the clearances available meet or exceed those given on the installation drawing.

Rope off the opening prior to beginning work!



**Figure 2**



**Figure 1**

# SECTION 5 - DOOR INSTALLATION CONTINUED...

## STEP 2 GUIDE MOUNTING - FACE MOUNTED (BRACKETS ABOVE LINTEL) SHUTTERS

**IMPORTANT:** If you don't have Face Mounted, the skip to Between Jamb (Brackets Under Lintel) Shutters.

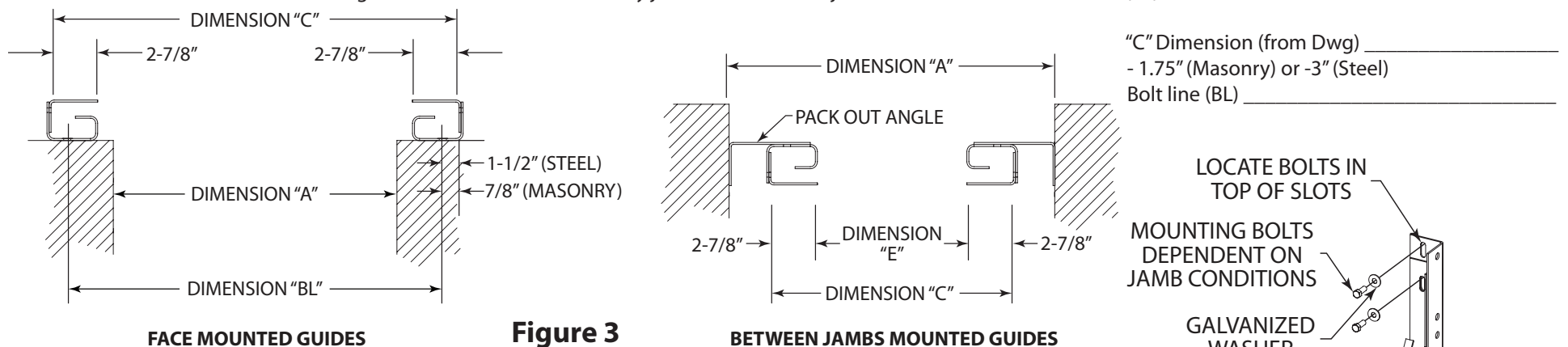
### ⚠ WARNING

**GUIDE ASSEMBLIES ARE EXTREMELY HEAVY. TO AVOID POSSIBLE INJURY, PERSONS WITH LIFTING LIMITATIONS SHOULD NOT PERFORM THIS NEXT STEP.**

#### FACE MOUNTED (BRACKETS ABOVE LINTEL) SHUTTERS:

The inner and outer guides are factory assembled, but must be disassembled in order to be installed (See **Figure 4**). Group the parts of each guide together as they are not interchangeable.

Refer to **Figure 3**. To determine the location of the "bolt line" (BL) for the guide mounting bolts on the wall, first locate and mark the center of the opening. Obtain the "C" dimension from the installation drawing and subtract 1.75" for masonry jambs or 3" for steel jambs to determine the bolt line (BL).



**Figure 3**

Divide BL in half (BL/2) and measure this distance either side of the opening center mark to obtain the bolt line on each jamb. Drop a plumb line down and make a second mark on the wall at the bottom of each jamb. Using a chalk line, snap a vertical line the length of the "F" dimension.

### ⚠ WARNING

**WELDING THE GUIDES TO THE JAMBS IS NOT ALLOWED DUE TO THE VERTICAL EXPANSION REQUIRED FOR THE SHUTTER TO FUNCTION PROPERLY.**

After determining guides are plumb, level and properly spaced, mark the location of the guide mounting slots on each jamb.

**NOTE:** FireStar® Fire Shutters are designed to expand upward. For this reason, mounting bolts must be located at the top of the slots.

**IMPORTANT:** The galvanized washers must be installed to ensure proper guide expansion in event of fire.

**Figure 4**

# SECTION 5 - DOOR INSTALLATION CONTINUED...

## STEP 2 GUIDE MOUNTING - FACE MOUNTED (BRACKETS ABOVE LINTEL) SHUTTERS CONTINUED...

Remove the guides and drill the appropriate size mounting holes for the fasteners provided (listed as "Guides-to-Wall" on hardware shipping list). Locate them in the TOP of the slot. Repeat this process for the remaining holes. Install top and bottom bolts in both guides with hardware provided. Check the Dimension "C" and compare with the installation drawing.

**IMPORTANT:** The guide to guide distance, or Dimension "C" on the installation drawing must be as specified. (See **Figure 3**). Using a string and a level, ensure that the guides are parallel to each other, shimming if necessary to achieve vertical and horizontal leveling. Now install the remaining bolts.

**IMPORTANT:** The fasteners supplied meet all NFPA 80 requirements set forth. Use of any other type fastener must be on the approved substitution list in NFPA 80 and cannot be of a lesser diameter.

### BETWEEN JAMBS (BRACKETS UNDER LINTEL) SHUTTERS:

The inner and outer guides are factory assembled, but must be disassembled in order to be installed.

Note that "PACK-OUT" angles are also required, and are slotted to match the guides.

Group the parts of each guide together since they are handed and not interchangeable.

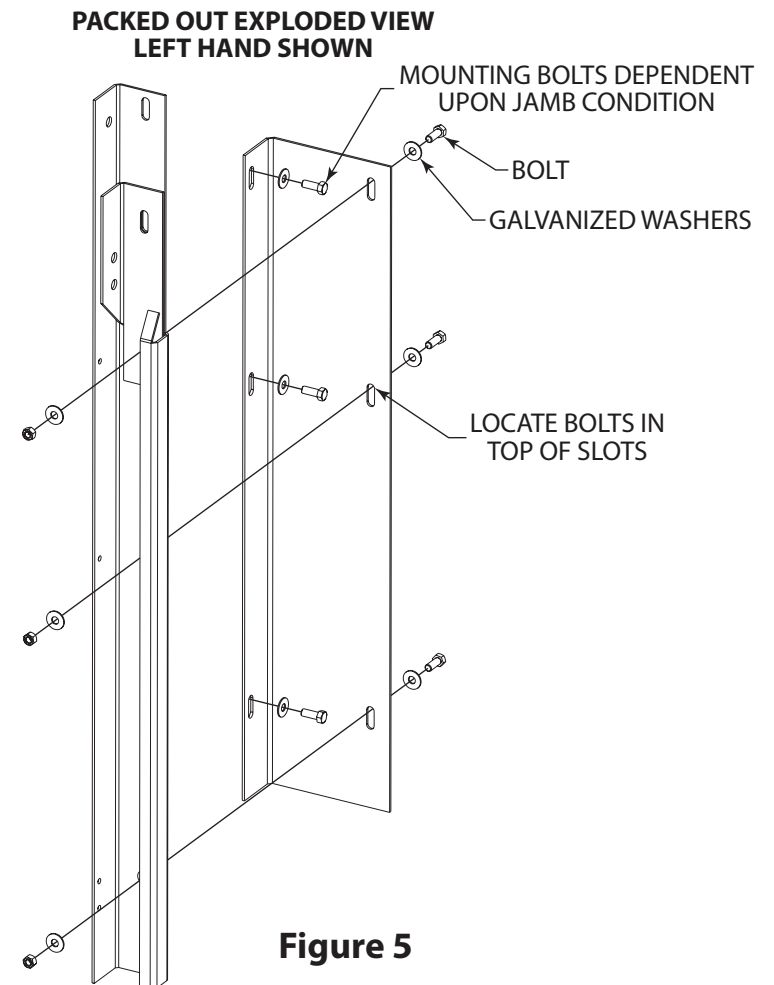
Next, determine the location of the "bolt line" (BL) for the guide mounting bolts on the wall.

(Follow this procedure for either masonry or steel jambs. See **Figure 3**).

Choose one guide/pack-out angle to be used as a template. Temporarily clamp the assembly in the proper jamb (i.e., left assembly in left jamb) at the exact location in the opening the shutter is to be mounted. After determining that the guide outer channel is plumb, level and properly spaced into the opening, carefully scribe the location of each pack-out angle mounting slot on the jamb. Repeat this procedure for the opposite side making sure that the channel is located at exactly the same distance into the opening.

Remove the guide angle assembly and drill the appropriate size mounting holes for the fasteners provided (listed as "Guides-to-Wall" on hardware shipping list). Locate them in the TOP of the slot. Repeat this process for the remaining holes. It is a good practice to align a chalk line with the center of the top and bottom slot, and snap a line to better locate the drill.

Install both the pack-out angle and outer guide angle together on each jamb starting with the top and bottom bolts using the hardware provided. Using a string and a level, ensure that the guides are parallel to each other, shimming if necessary to achieve vertical and horizontal leveling. Now install the remaining bolts.



**Figure 5**

# SECTION 5 - DOOR INSTALLATION CONTINUED...

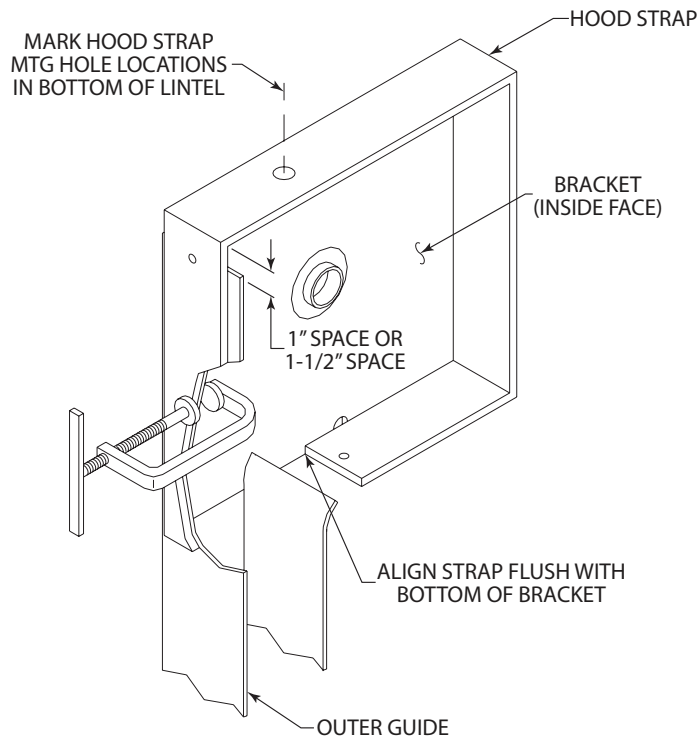
## STEP 3 LOCATE HOOD STRAPS & FLAME BAFFLE

**IMPORTANT:** This Section Applies to Between Jamb (Brackets Under Lintel) Shutters Only. Skip to **STEP 4** if Shutter is “face mounted” i.e., brackets above lintel.

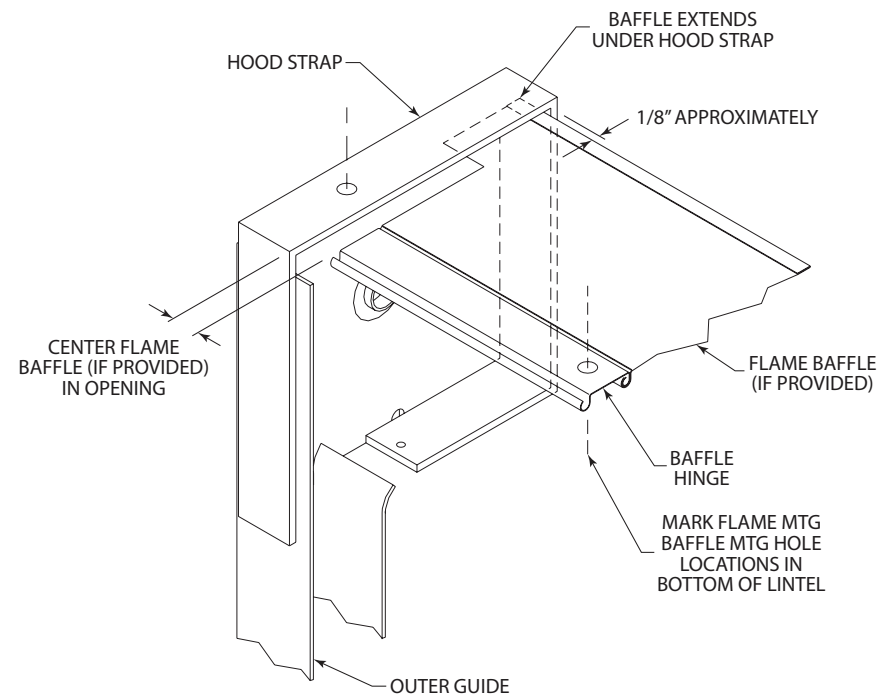
If the brackets are “under lintel”, the mounting holes for the hood straps and flame baffle must be drilled prior to erecting the barrel and curtain assembly. Temporarily attach the brackets to the guides. (Refer to **Figure 6**). Position each hood strap tightly against and flush with the front and bottom of each bracket as shown in **Figure 6**. The back of the hood strap should loop over the top and back side of the guide.

**NOTE:** A 1” to 1-1/2” space exists between the top of the bracket and the bottom of the lintel, since FireStar® shutters are designed to expand Upward (see installation drawing for exact dimension).

Clamp the hood straps to the guides temporarily and use the straps as a template to scribe the location of the mounting holes under the lintel. Position the flame baffle (if provided) under the lintel as shown in **Figure 7** with the hinge to the back and centered between the hood straps. A clearance of 1/8” should be held from edge of the baffle to the inside face of the hood straps (see **Figure 7**). Check to see that the baffle swings down freely and also will catch on the flame baffle fuse (attached to the front hood) which supports it. Mark the position under the lintel for three equidistant holes through the hinge. Remove the flame baffle, hood straps, and brackets and drill the marked holes in the lintel.



**Figure 6**



**Figure 7**

# SECTION 5 - DOOR INSTALLATION CONTINUED...

## STEP 4A BARREL/BACKET ASSEMBLY - MANUAL LIFT-UP AND AWNING CRANK OPERATED

### ⚠ WARNING

SPRINGS ARE CLOSER TO ONE SIDE OF BARREL ASSEMBLY, CAUSING THAT SIDE TO BE HEAVIER. BARREL ASSEMBLY WILL FALL IF LIFTED FROM CENTER. TO AVOID POSSIBLE SEVERE OR FATAL INJURY, CAREFULLY DETERMINE BALANCE POINT, PRIOR TO LIFTING BARREL ASSEMBLY, TO PREVENT BARREL ASSEMBLY FROM FALLING.

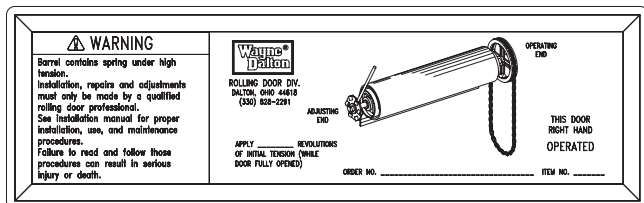
### ⚠ WARNING

BRACKET ASSEMBLIES CAN BE HEAVY. TO AVOID POSSIBLE INJURY, PERSONS WITH LIFTING LIMITATIONS SHOULD NOT PERFORM THIS NEXT STEP.

Lay the barrel assembly in front of the opening. Note the sticker located on the barrel. This sticker will indicate the operated end, the direction the curtain uncoils to close the shutter, and the spring turns required to balance the shutter. Slide the set collar, and then the thrush bearing, onto the push down shaft. Slide the brackets onto the barrel shaft extensions and place the brackets on wood blocks. Install a cotter pin onto the barrel shaft extension (with the flat) (do not install the adjusting wheel at this time). Install the sprocket, 1/4" shaft key, and snap ring onto the shaft. Locate the sprocket so that it contacts the snap ring, and tighten the set screws. Next, move the inner set collar and thrust bearing (between the barrel and inside surface of the bracket) against the inside bearing race on the bracket, and tighten the set screws (prevents lateral barrel shaft movement).

**IMPORTANT:** Determine proper orientation of barrel as indicated by sticker on barrel (examples below).

### Right Hand Sticker



### Left Hand Sticker

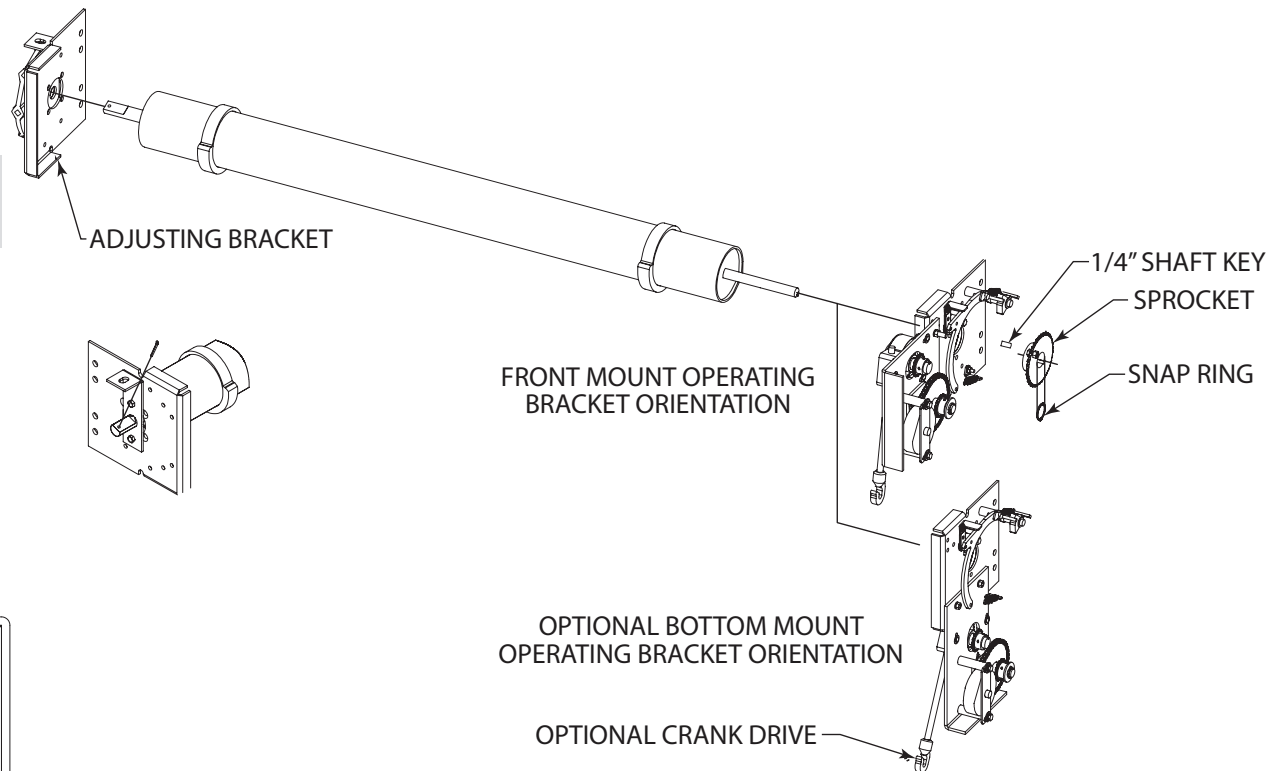
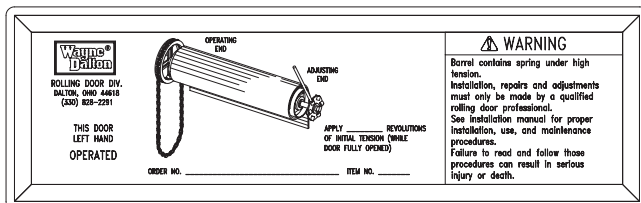


Figure 8

# SECTION 5 - DOOR INSTALLATION CONTINUED...

## STEP 4A BARREL/BRACKET ASSEMBLY - MANUAL LIFT-UP AND AWNING CRANK OPERATED CONTINUED...

### ⚠ WARNING

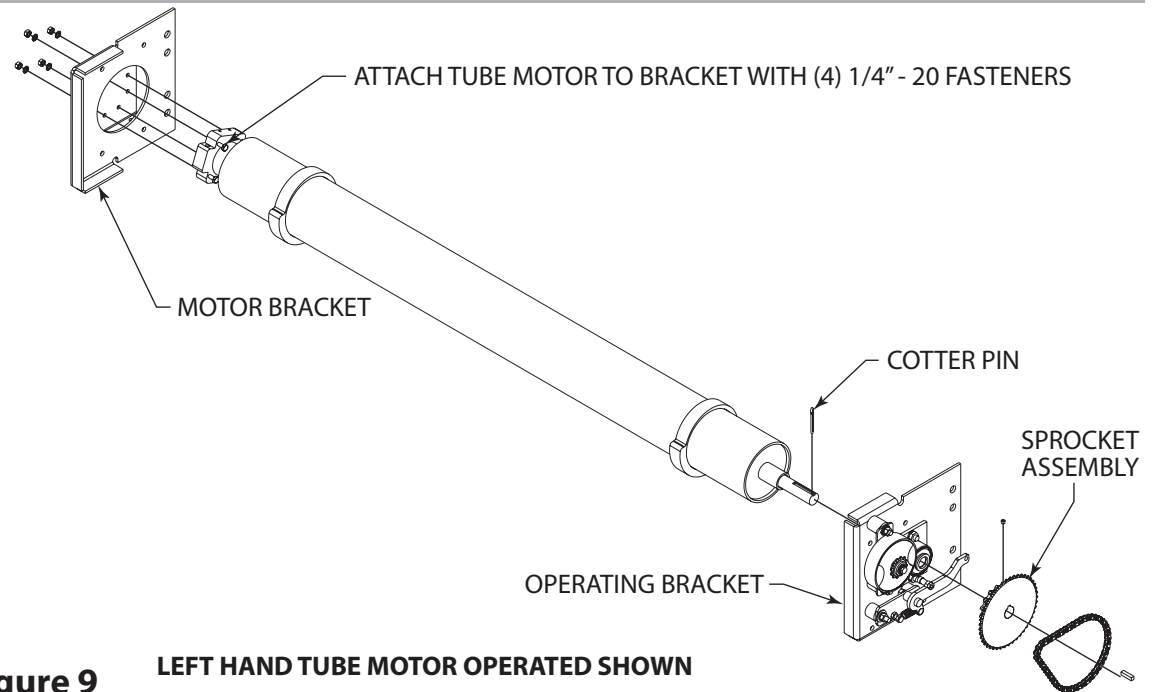
SECURE BRACKET TO BARREL ASSEMBLY USING SUPPLIED COTTER PIN, OR VISE GRIPS, TO PREVENT IT FROM SLIDING OFF DURING LIFTING. FAILURE TO SECURE BRACKET TO BARREL ASSEMBLY COULD RESULT IN SEVERE OR FATAL INJURY.

### ⚠ CAUTION

ALL PARTS (EXCEPT KEYS) ARE DESIGNED FOR A SLIP FIT. FORCING PARTS TOGETHER MAY RESULT IN DAMAGE LEADING TO MALFUNCTION.

## STEP 4B BARREL/BRACKET ASSEMBLY - TUBE MOTOR OPERATED

Install the operating bracket assembly while the barrel is still resting on the wooden blocks.



## STEP 4C BARREL/BRACKET ASSEMBLY – GCX MOTOR OPERATED

Slide the brackets onto the barrel shaft extensions and place the brackets on wood blocks. The GCX operator will be installed after the barrel and brackets are secured to the guides. (STEP 11C).

# SECTION 5 - DOOR INSTALLATION CONTINUED...

## STEP 5 ATTACHING BRACKETS TO GUIDES

Determine the best method of lifting the barrel and brackets to prevent damage during installation.

### ⚠ WARNING

**BRACKET AND BARREL ASSEMBLY ON LARGER SHUTTERS, PARTICULARLY WITH AN OPERATOR, CAN BE EXTREMELY HEAVY. PERSONS WITH BACK PROBLEMS OR OTHER PHYSICAL CONDITIONS WHICH MAY LIMIT THEM FROM LIFTING HEAVY OBJECTS SHOULD NOT PERFORM THE NEXT STEP. USE A MULTI-PERSON CREW OR LIFTING EQUIPMENT SUCH AS A FORKLIFT WHEN APPROPRIATE.**

### ⚠ WARNING

**SECURE BRACKETS TO BARREL ASSEMBLY TO PREVENT IT FROM SLIDING OFF DURING LIFTING, POSSIBLY CAUSING SEVERE OR FATAL INJURY.**

Lift the barrel and brackets to the bracket mounting holes provided on the channel shaped outer guide. Bolt the bracket and guides together, making sure the bracket is positioned inside the guide.

**IMPORTANT:** The bolt heads must be on the inside (threaded section out) to prevent interference with the operation of the coil.

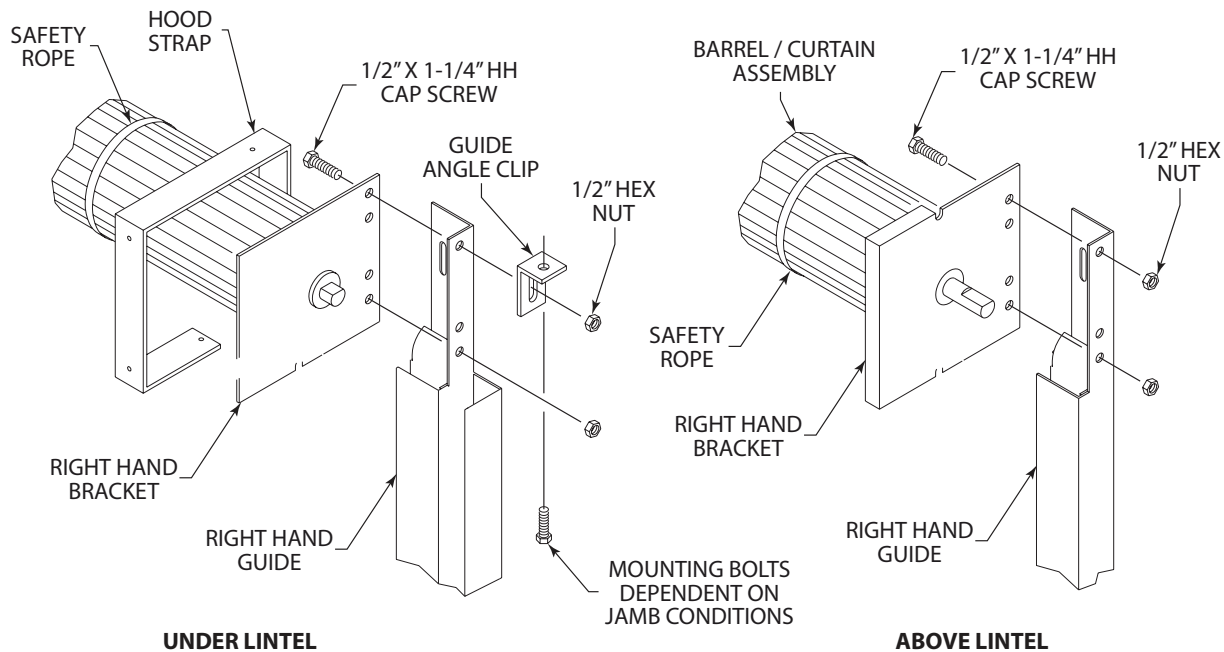


Figure 10

# SECTION 5 - DOOR INSTALLATION CONTINUED...

## STEP 6 ATTACHING CURTAIN

### ⚠ WARNING

**CURTAIN MUST BE SECURELY ATTACHED TO LIFTING MECHANISM. OTHERWISE, CURTAIN COULD FALL CAUSING POSSIBLE SEVERE OR FATAL INJURY.**

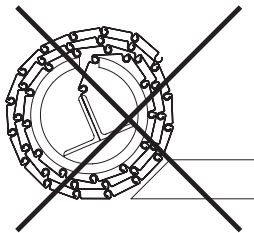
### ⚠ WARNING

**BANDING IS UNDER TENSION. TO AVOID POSSIBLE INJURY, WEAR EYE PROTECTION AND DO NOT STAND IN FRONT OF BANDING WHEN CUTTING IT.**

### ⚠ CAUTION

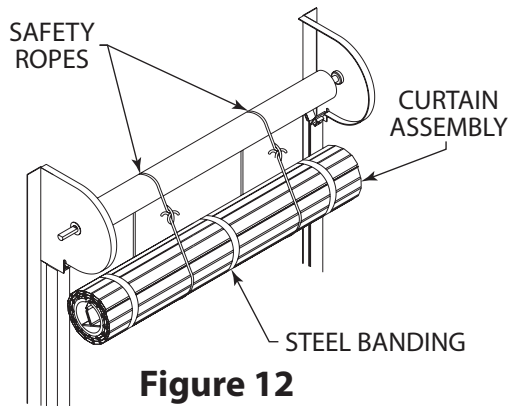
**DO NOT ATTEMPT TO SLIDE FORKS OF LIFT TRUCK DIRECTLY BETWEEN FLOOR AND CURTAIN. PERMANENT DOOR DAMAGE MAY RESULT.**

Position the curtain assembly parallel with the door opening so that the top attachment slat is in front of the rest of the curtain (the hinged part away from the opening).



**Figure 11**

Lift curtain assembly (centered between guide assemblies) and suspend approximately one foot below the barrel assembly, using ropes or straps of adequate strength to safely support curtain assembly weight. Remove steel banding from around curtain assembly.



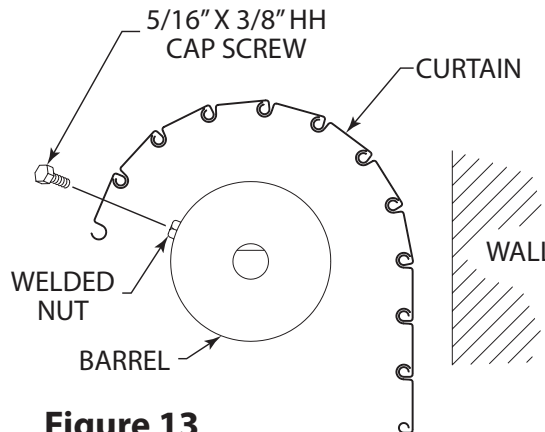
**Figure 12**

### ⚠ WARNING

**NO TENSION HAS YET BEEN APPLIED TO DOOR. IF CURTAIN IS ALLOWED TO ROTATE AND FREE FALL, SEVERE OR FATAL INJURY COULD RESULT. KEEP THE CURTAIN SECURE AND PREVENT FROM ROTATING.**

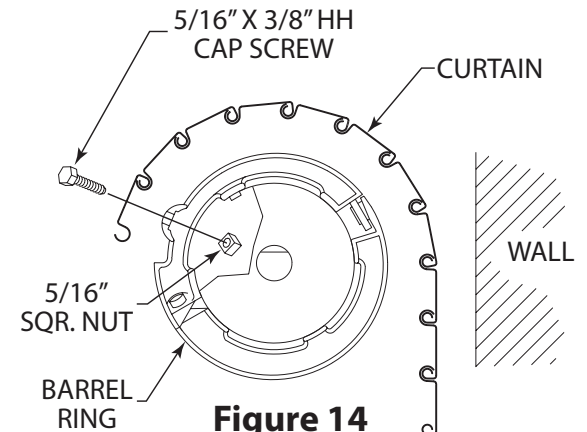
Rotate barrel assembly until top slat attachment point is accessible. Feed top slat around back side of barrel assembly until top slat is out in front of barrel assembly. Install the top slat attachment bolts and nuts, verifying that the curtain is centered between the brackets.

Continue rolling the curtain up around the barrel assembly until the entire curtain is coiled onto the barrel assembly. Clamp or block the guide assembly approximately 6" down from the top of the guides. Loosen the safety ropes enough to let the curtain feed into the guide grooves.



**Figure 13**

**BARE PIPE**



**Figure 14**

**WITH RINGS**

# SECTION 5 - DOOR INSTALLATION CONTINUED...

## STEP 7 INSTALLING INNER GUIDE ASSEMBLY

With the curtain and barrel assembly (not shown for clarity) now mounted to the guides and secured to prevent curtain from dropping, proceed to install the inner guide assembly. Position the bottom bar inside the channel shaped outer guides approximately 3"-4" below the top of the guide opening.

Install the bottom bar stops to the inner guides as shown in **Detail "B"**.

Position the correct inner guide into the outer guide so that the inner angle holes line up with the outer guide slots. Attach the inner guide using the truss head bolts and acorn nuts that were shipped installed in the guide assembly.

Repeat this procedure with the opposite guide assembly.

Install the slide lock strike tabs (if ordered with locks).

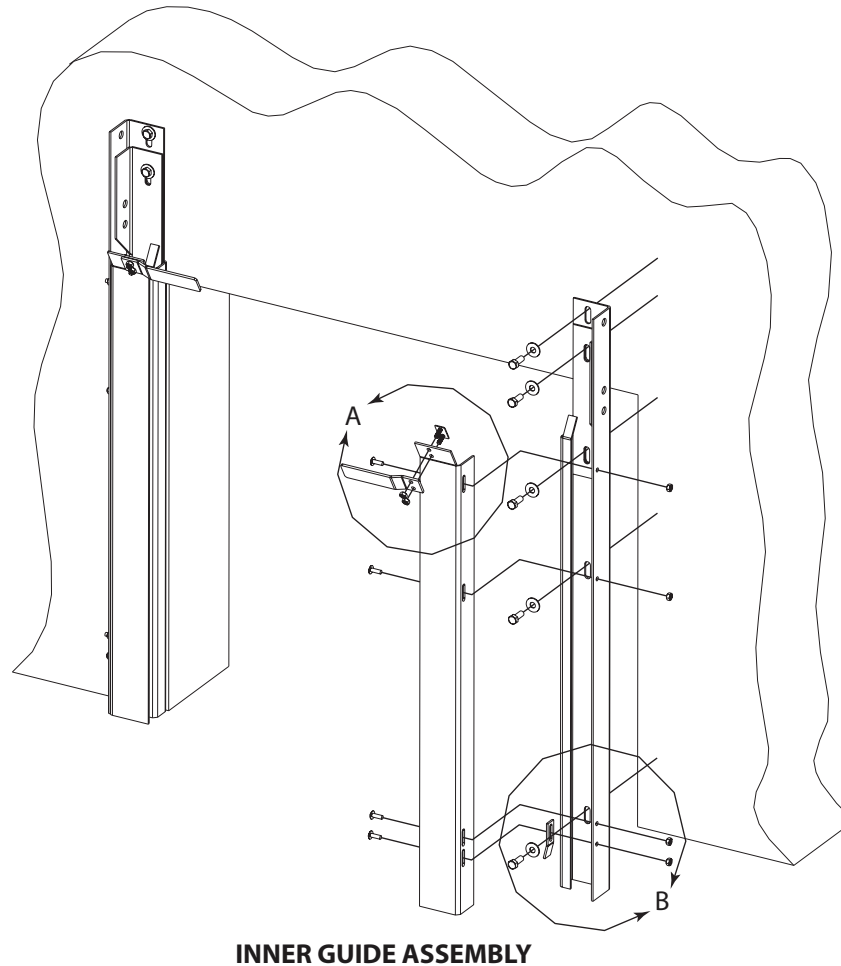
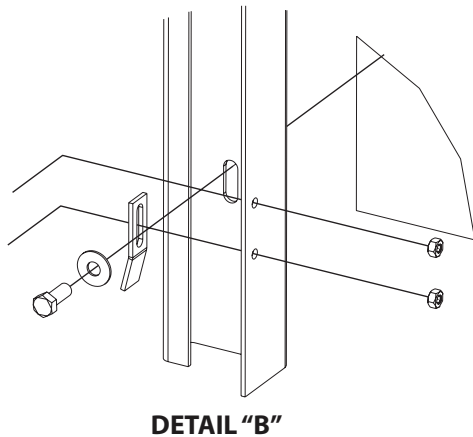
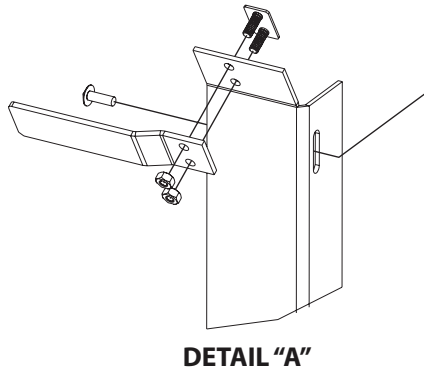


Figure 15

# SECTION 5 - DOOR INSTALLATION CONTINUED...

## STEP 8 APPLYING COUNTERBALANCE SPRING TENSION (MANUAL LIFT-UP, CRANK, AND GCX MOTOR OPERATION ONLY)

### CAUTION

**ALWAYS WIND COUNTERBALANCE SPRING TENSION WHEN THE SHUTTER IS IN THE UP POSITION. THE SPRINGS ARE UNDER THE LEAST AMOUNT OF TENSION AT THIS POINT.**

**IMPORTANT:** The amount of initial revolutions (IR's) as indicated on the installation drawing and on the barrel "rev tag" is the THEORETICAL STARTING POINT for the required spring tension. In most cases this figure is correct, but due to variations in steel, springs, friction, etc., slight adjustments may be required.

Install the adjusting wheel and cotter pin as shown. Using approved winding bar, rotate the adjusting wheel (AW) slightly in both directions to determine the neutral point of the tension shaft. Insert the two winding bars securely into the holes in the AW.

### WARNING

**VERIFY THAT AT THIS POINT, THE ADJUSTING WHEEL IS FREE AND THERE IS NO SPRING TENSION.**

**IMPORTANT:** Tension is applied in the direction as the shutter would turn as it coils upward (opposite the direction of the arrow on the "rev tag").

**NOTE:** If conditions permit, use wall as brace for winding bar for a safe procedure of installing the AW pin as shown.

### WARNING

**EXERCISE CAUTION WHEN APPLYING OR ADJUSTING SPRING TENSION. CONTACT WITH RAPIDLY ROTATING ADJUSTING WHEEL OR EXPELLED WINDING BAR CAN CAUSE SERIOUS INJURY OR DEATH. USE TWO (NOT PROVIDED) WINDING BARS 1/2" DIAMETER STEEL ROD, MINIMUM 18 INCHES LONG.**

**NOTE:** Apply the initial revolutions (IR's) marked on the rev tag and installation drawing. The IR's are the required number of turns (of the spring) to hold the curtain in the open position.

While holding the winding bar firmly in one hand, insert the AW pin with the other hand through the lug in the bracket and into the hole in the AW to lock the AW at the specified number of revs. Remove winding bars.

**IMPORTANT:** Apply only enough tension to hold the shutter in the up position against the bottom bar stops. This is the optimum setting, as too much tension could prevent the shutter from dropping when the release lever or fusible link is activated.

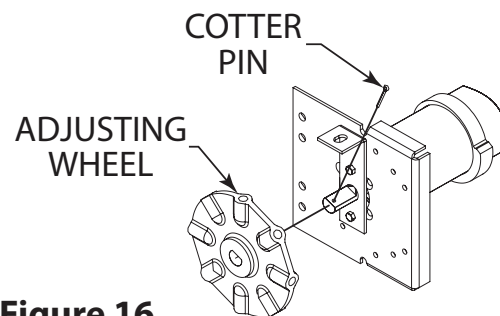


Figure 16

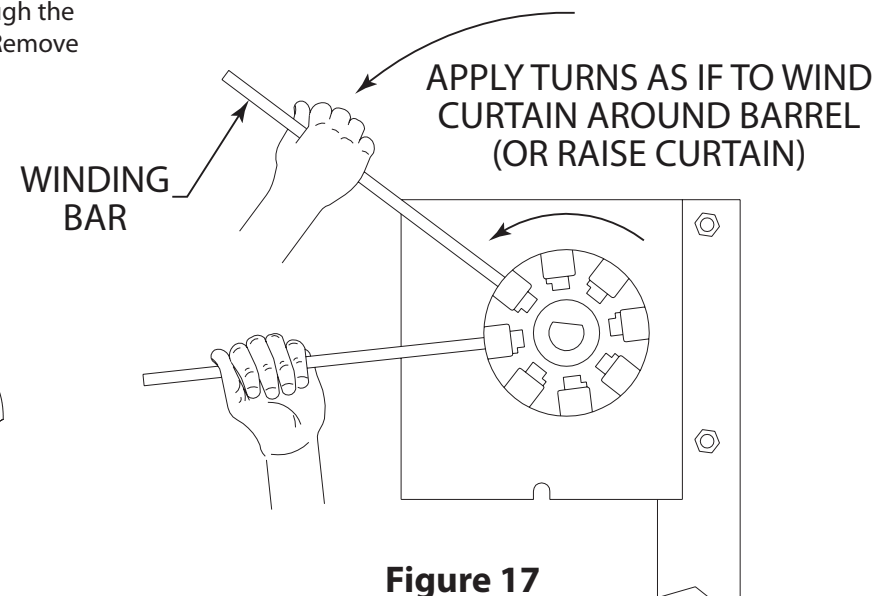


Figure 17

## SECTION 5 - DOOR INSTALLATION CONTINUED...

**STEP 9** TESTING THE SHUTTER BALANCE (MANUAL LIFT-UP, CRANK, GCX MOTOR OPERATOR ONLY)

### CAUTION

**INCREASING THE INITIAL TENSION WILL REDUCE THE LIFT EFFORT BUT CAN PREVENT AUTOMATIC CLOSURE WHEN REQUIRED TO DO SO UNDER ACTUAL FIRE CONDITIONS. DO NOT OVER WIND.**

With the adjusting wheel locked, operate the shutter through several cycles to check shutter balance. If the shutter does not balance properly and requires further spring adjustment, repeat the procedure for "Applying Tension" to add or remove spring tension. Ideally, the shutter should have sufficient spring tension to just allow the shutter to stay up in the open position and no more.

# SECTION 5 - DOOR INSTALLATION CONTINUED...

## STEP 10 LEVEL DOOR (IF NEEDED)

**IMPORTANT:** If during previous step the door rolled up level and straight, skip this step.

- A. Check that guides are plum, square, level, and are properly mounted onto floor and wall.
- B. Check that the pipe is level.
- C. Check that the attachment of the curtain is straight on the pipe.

If all of the above is correct and the door still rolls up out of level, a shim may need to be added, as shown in **Figure 18**.

### SHIM MATERIALS:

- A piece of rubber is the desired material for a shim.
- A piece of cardboard could be used but may deteriorate over time.
- Use a 1/8" x 6" x 6" thick piece of material and increase thickness or pieces depending on the result acquired, as shown in **Figure 19**.

### APPLICATION OF SHIM:

- To determine the side in which the shim will be applied, the door will need to be in the open position.
  - When facing the door, the bottom bar will be unlevel. The lower side of the bottom bar will be the side in which the shim needs to be placed.
  - The hood may need to be loosened or removed for the application of the shim.
- To apply the shim, two laborers might be required.

### INSTALLING THE SHIM:

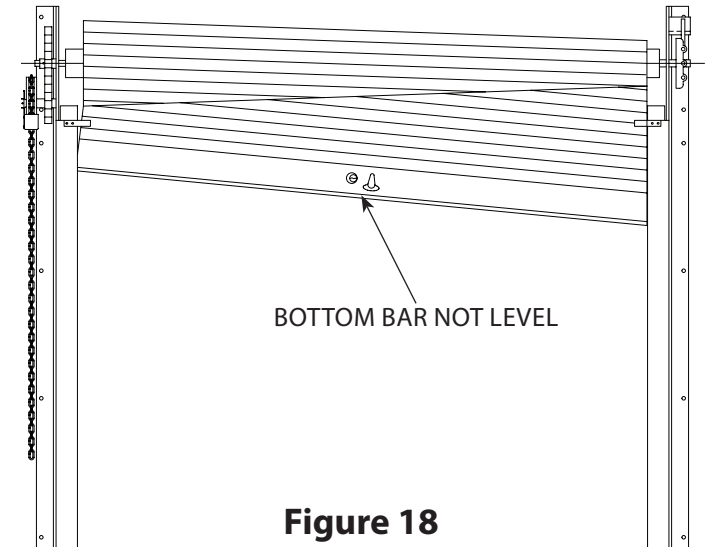
- D. Close the door fully.
- E. When door is at bottom make sure door is in hand chain mode.
- F. Turn off the power to the motor (if applicable) to ensure safe application of the shim.
- G. Back wind the door using the chain. Lock chain in place using chain keeper.

## ⚠ WARNING

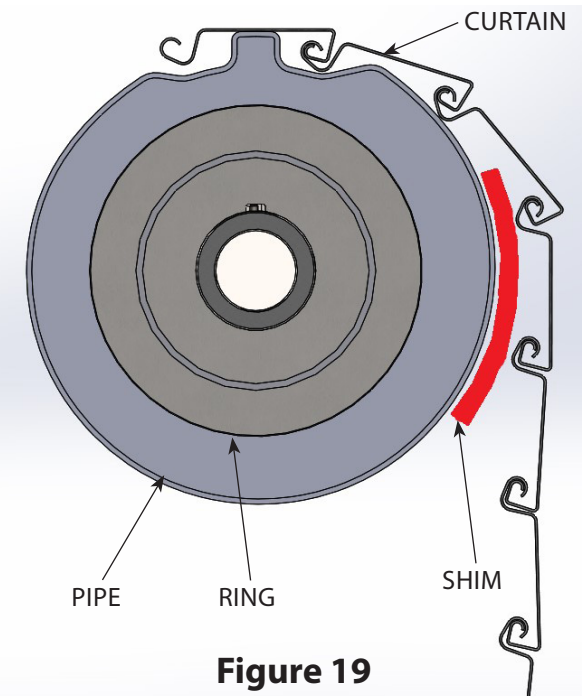
**WHEN THE DOOR IS WOUND BACKWARDS THERE IS A FORCE IN WHICH THE DOOR WILL WANT TO WIND FORWARD. SECURE THE DOOR IN THIS POSITION BY LOCKING HAND CHAIN ONTO CHAIN KEEPER TO PREVENT INJURY.**

- H. As the curtain is wound backwards apply the shim to the lower side between the pipe and slats or on the ring of the low side.
- I. Restore power to the motor (if applicable).
- J. Check the level of the bottom bar while door is in the open position. If it is not level, add a second shim and check again.

**NOTE:** If the door has wind locks there may be some stacking interference in the wind locks as the door is wrapping during operation. This is a normal characteristic. For wind lock applications the doors bottom bar should be level at the open position..



**Figure 18**



**Figure 19**

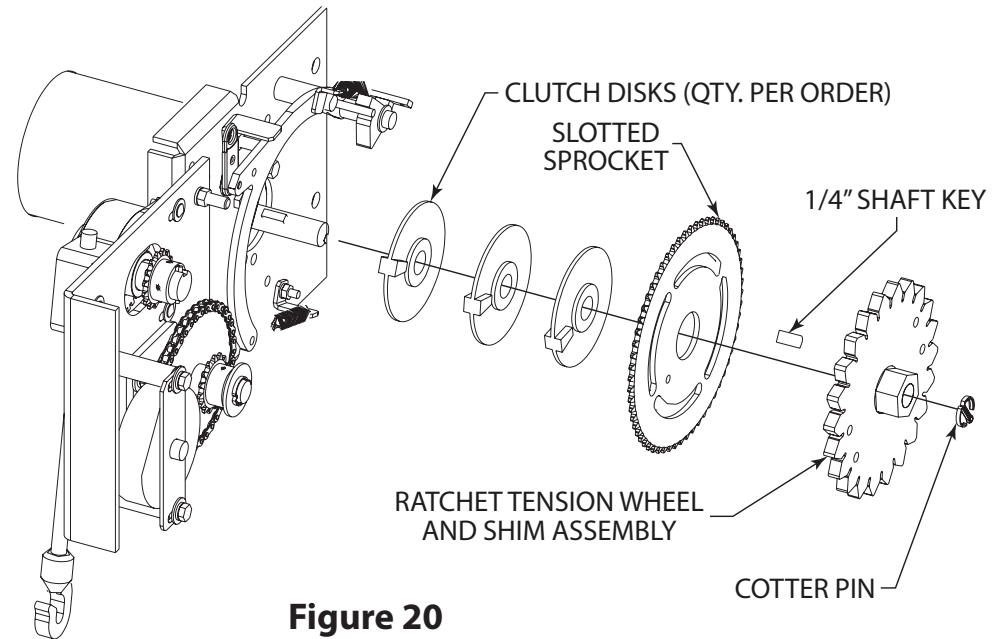
# SECTION 5 - DOOR INSTALLATION CONTINUED...

## STEP 11A MANUAL LIFT-UP AND CRANK OPERATION

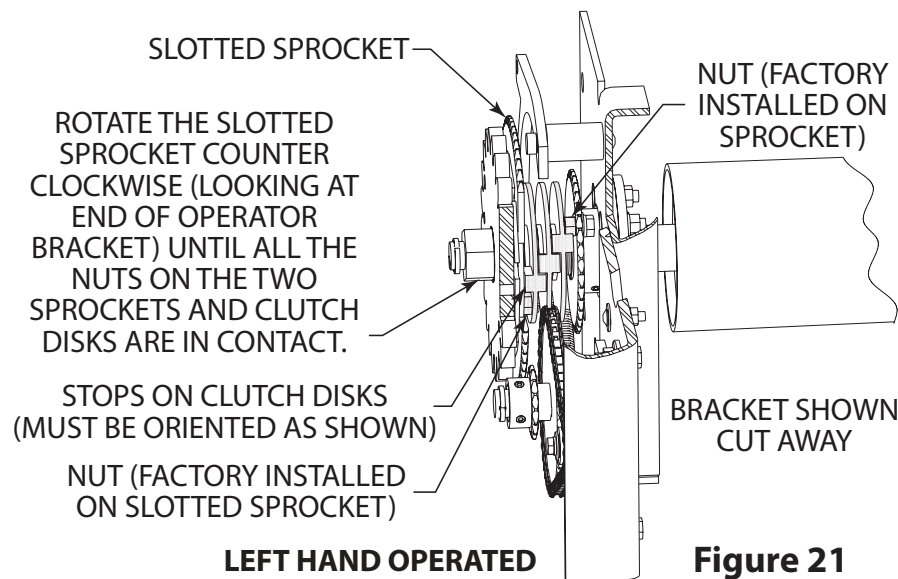
**IMPORTANT:** Winding the counterbalance spring (**STEP 8**), must be completed prior to performing these next steps. Door must be in fully **CLOSED** position.

### INSTALLING THE DROP MECHANISM COMPONENTS:

Install the clutch disks onto the 3/4" diameter shaft. Install the slotted sprocket, spacer, 1/4" shaft key and ratchet tension wheel as shown. Fasten the cotter pin in the end of the 3/4" shaft, to secure the components from moving laterally. Tighten all set screws on the door sprocket and inner set collar. Verify that the clutch disks rotate freely. Orient the clutch disks and slotted sprocket as shown below:

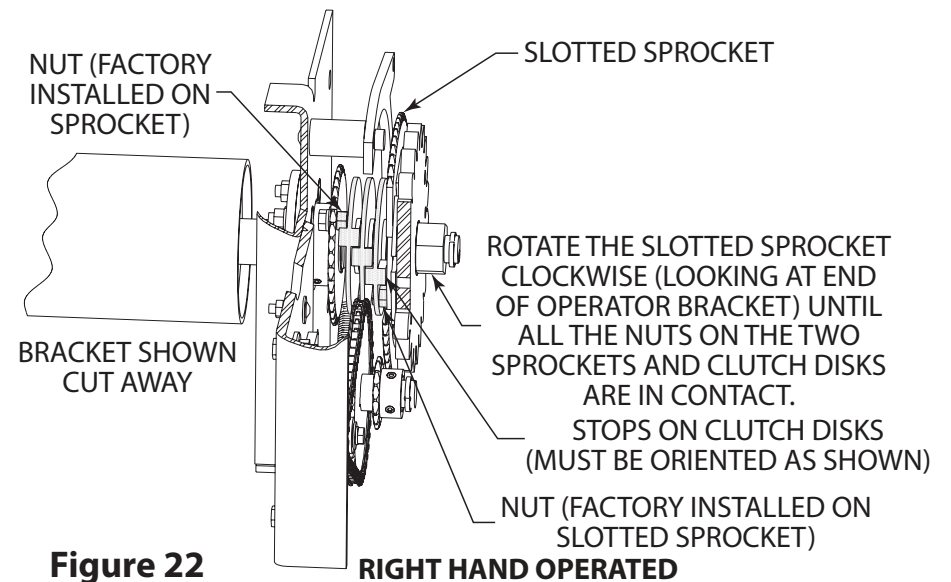


**Figure 20**



**LEFT HAND OPERATED**

**Figure 21**



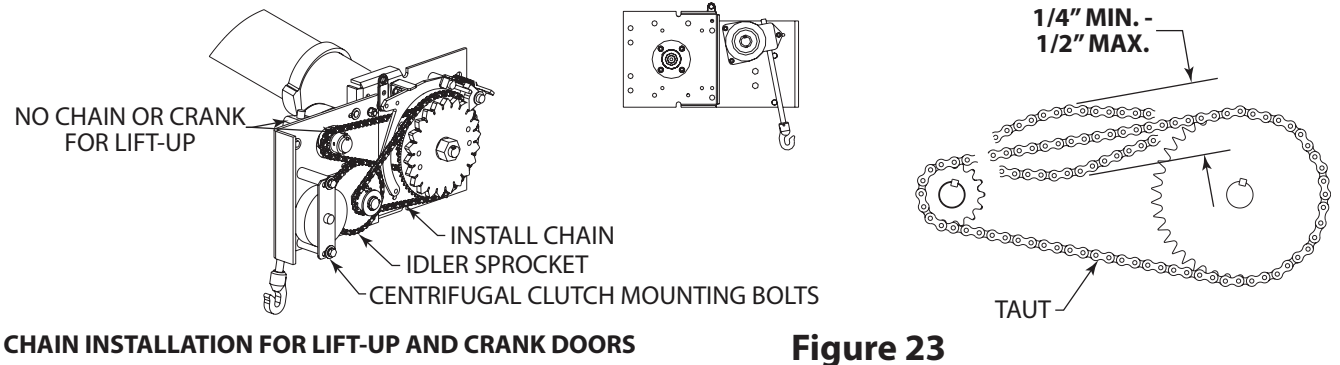
**RIGHT HAND OPERATED**

**Figure 22**

# SECTION 5 - DOOR INSTALLATION CONTINUED...

## STEP 11A MANUAL LIFT-UP AND CRANK OPERATION CONTINUED...

Install the chain from the slotted sprocket to the idler sprocket, and if crank operated, install the chain from the drive sprocket on the awning crank to the door sprocket. Adjust each chain so that there is 1/4" to 1/2" of slack as shown for proper operation and automatic closure functionality. The idler sprocket and chain tension is adjustable by loosening the mounting bolts on the opposite side. (If the idler sprocket location is adjusted, the centrifugal clutch chain tension will also require adjustment). Re-tighten all bolts and nuts.



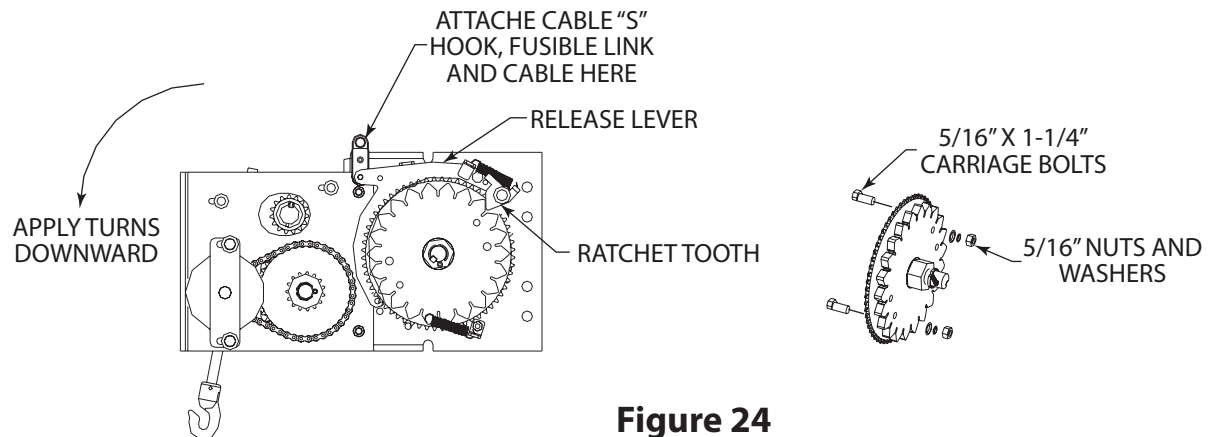
### **WARNING**

**EXERCISE CAUTION WHEN APPLYING, ADJUSTING, AND SECURING SPRING TENSION. CONTACT WITH RAPIDLY ROTATING TENSION WHEEL OR EXPELLED WRENCH CAN CAUSE SERIOUS INJURY OR DEATH.**

### **WARNING**

**ACTIVATING THE TEST HANDLE WILL RELEASE SPRING FORCES, CAUSING THESE PARTS TO SPIN RAPIDLY AND CAN POTENTIALLY CAUSE SEVERE INJURY TO ANY PERSON IN CONTACT. ENSURE RELEASE LEVER AND TEST HANDLE ARE IN THE LOCKED POSITION AND SECURED BEFORE AND DURING THE TIME YOU PERFORM THIS STEP.**

Now, the push-down spring (connected to the 3/4" diameter shaft) must be wound. The shutter must be in the **CLOSED** position. Install the test handle, fusible links, turnbuckles and cable and attach to the release lever (per **Figure 24**). Rotate the release lever upwards and secure it so that the ratchet tooth engages the tension wheel teeth. Using a pipe wrench, rotate the tension wheel downwards (towards the floor) and apply 1-1/2 to 1-3/4 full turns of tension on the push-down spring. Install the (2) 5/16"-18 x 1-1/4" carriage head bolts through the slotted sprocket, spacer, and ratchet tension wheel and tighten them securely with the washers, lock washers, and 5/16" nut.



**Figure 24**

# SECTION 5 - DOOR INSTALLATION CONTINUED...

## STEP 11B TUBE MOTOR OPERATION

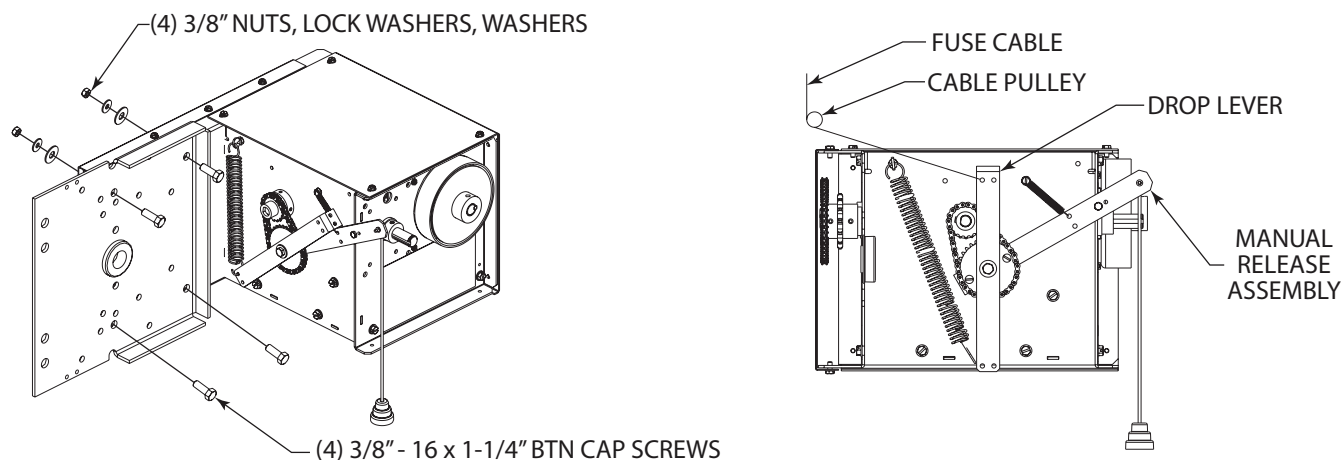
Install the tube motor, wiring, and push button, and set the door limits per the tube motor supplied instructions.

**NOTE:** The test handle must be engaged to operate the shutter.

## STEP 11C GCX MOTOR OPERATION

Install the GCX operator to the bracket with (4) 3/8" - 16 x 1-1/4" button cap screws, nuts, and washers as shown. Install the door sprocket, roller chain, operator wiring, and push button, and set the door limits per the GCX operator supplied instruction manual. The drop lever must be installed so that it is perpendicular to the floor, when the fuse cable is routed and the test handle is engaged. The fuse cable should be routed so that it forms a 90° angle (approximate) to the drop lever (see **Figure 25**).

**NOTE:** The test handle must be engaged to operate the shutter.



**Figure 25**

# SECTION 5 - DOOR INSTALLATION CONTINUED...

## STEP 12 FUSIBLE LINKS AND CABLE ROUTING

Fusible links are designed to melt in the event of a fire and are shipped in a package with the door. The links must be located in such a way that they will be exposed to any fire that may be inside the building. If shutters are installed on both sides of the opening, it is recommended that the cables and fusible links should be interconnected so that both shutters close during a test or detector activation. The Authority Having Jurisdiction may require this, and Factory Mutual (FM) requires this.

### CAUTION

**PER NFPA 80 FUSIBLE LINKS MUST BE LOCATED NO MORE THAN 18 INCHES BELOW THE CEILING ON BOTH SIDES OF THE SHUTTER OPENING, AND NEAR THE SHUTTER OPENING ON THE SIDE THE SHUTTER IS MOUNTED. PLEASE NOTE THAT WAYNE DALTON'S WARRANTY WILL NOT COVER DAMAGE CAUSED BY FAILURE OF THE MOTOR, CONTROL PANEL OR OTHER ELECTRICAL COMPONENTS DUE TO THE USE OF AN INADEQUATELY GROUNDED SYSTEM.**

**IMPORTANT:** The release lever must drop regardless of which connection in the cable separates.

In addition to fusible links, some codes and construction will require the door to be integrated into the building's fire alarm system. This can be done with electro-mechanical devices such as the Waynegard . For such devices, see the installation instructions included with them.

Generally any fusible link must be at least 6" away from any fixed point (ex: turnbuckle, pulleys etc.) or sufficient enough that the drop out mechanism and tension release arm can swing down (see **APPENDIX D** for additional information).

**IMPORTANT:** A fuse link housing is required if a drop ceiling exists above the shutter opening in order to comply with the provisions of NFPA 80 and in order to keep the fuse link exposed to the heat of a potential fire, rather than being located above the drop or false ceiling.

Install the test handle as shown. Adjust cable tension using turnbuckles.

## STEP 13 TEST DROP PROCEDURE

### PREPARE TO TEST DROP:

**IMPORTANT:** Prior to dropping the shutter, ensure the shutter operates freely and properly in normal operation.

### WARNING

**REMOVE THE AWNING CRANK WINDING SHAFT PRIOR TO TEST DROPPING THE SHUTTER! THE AWNING CRANK ROTATES RAPIDLY DURING TEST PROCEDURE, AND COULD CAUSE SEVERE INJURY.**

### WARNING

**ROPE OFF THE OPENING TO KEEP PERSONS FROM ENTERING AREA DURING TEST DROP. ENSURE ALL PERSONS ARE KEPT CLEAR OF THE OPENING AND THE OPENING IS FREE OF OBJECTS AND DEBRIS. THE SHUTTER DESCENDS RAPIDLY DURING TEST PROCEDURE AND COULD CAUSE SEVERE INJURY.**

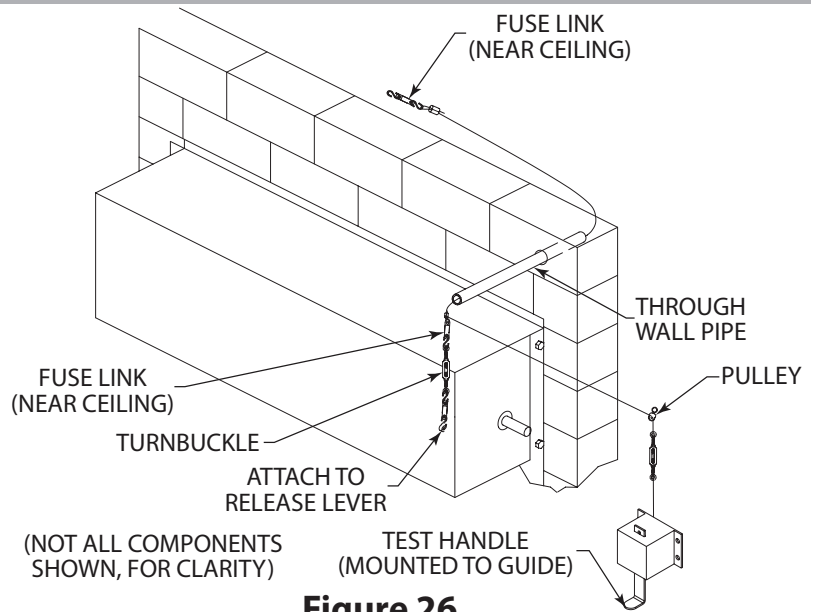


Figure 26

# SECTION 5 - DOOR INSTALLATION CONTINUED...

## STEP 13 TEST DROP PROCEDURE CONTINUED...

### TEST DROP THE SHUTTER AS FOLLOWS:

Activate the test handle. Record the amount of time the shutter takes to close and verify it closes between 6 to 24 inches per second. To reset the shutter, insert the pin into the test handle. For tube motor or GCX motor operated shutters, the shutter is ready to be operated.

**NOTE:** For GCX operators, verify that the manual release arm travels fully upward, to re-engage the operator, as shown in **Figure 25**.

For manual lift-up and crank operated shutters, the push-down spring must be reset. This is accomplished by raising the shutter to the fully open position. At this point the shutter is ready for normal operation, no tools are required. Repeat procedure to verify it is working correctly. Complete the release form in the back of this manual and return it to the factory.

## STEP 14 VERIFY DROP SPEED

For manual lift-up operated or crank operated shutters: if drop speed is less than 6" per second, increase the push-down spring tension. If the drop speed is more than 24" per second, reduce the push-down spring tension. (per **STEP 11A**). If the drop speed cannot be adjusted to within 6" and 24" per second, contact Wayne Dalton™.

## STEP 15 HOODS, SUPPORTS AND HOUSINGS (UNDER LINTEL)

**NOTE:** Skip to next section for brackets mounted above lintel.

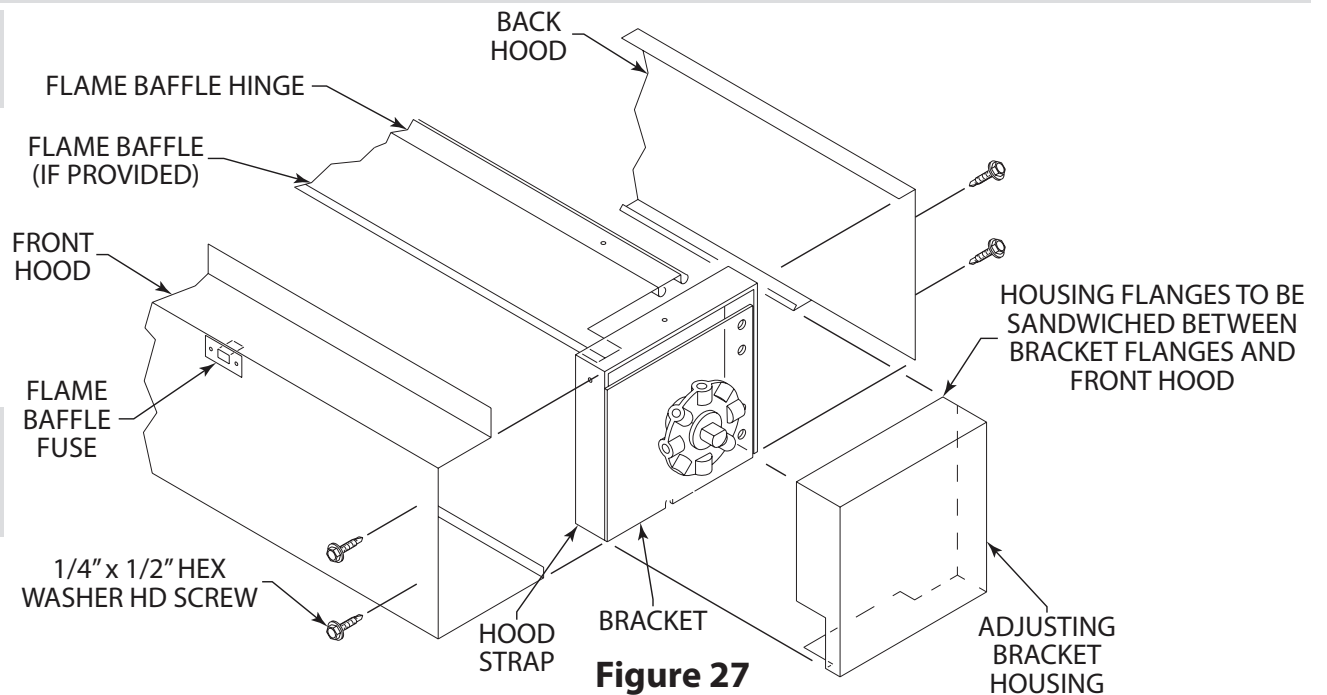
**NOTE:** Lower the shutter to offer the maximum clearance between the coil and the lintel. Refer to **Figures 27 and 28**. Install the flame baffle and hood straps in the lintel holes prepared earlier. Test the flame baffle for freedom of movement. It should have the ability to swing down and rest on the barrel/coil assembly without restricting door operation.

**IMPORTANT:** The front hood may contain a flame baffle fusible tab located inside. The flame baffle (if provided) must rest above this tab and be contained by it (see **Figure 28**).

**NOTE:** NFPA 80 does not approve the use of lead anchors on rolling fire shutter installations; do not use lead anchors.

Temporarily prop the flame baffle in its upper-most position before attaching the front hood. This will insure it is guided into this position. Remember to remove the props later. Position the front hood on the hood straps. Align and punch all holes in the hood at the hole locations in the hood straps. Attach the front hood with the self-tapping screws provided, but **DO NOT** tighten the screws at this time, since the housings must slide under the front hood.

**NOTE:** If the shutter is mounted totally under the lintel and the fascia side is accessible, it may be easier to install the front hood first, then slide in the flame baffle (if required) from the fascia side.



## SECTION 5 - DOOR INSTALLATION CONTINUED...

### STEP 15 HOODS, SUPPORTS AND HOUSINGS (UNDER LINTEL) CONTINUED...

Attach the A.W. bracket housing and sandwich the flanges between the hood straps and the front hood (see **Figure 29**). Check to insure the cutouts, as provided, are large enough so as not to interfere with the drop arm throughout its travel. Trim if necessary. Now tighten all screws in the vicinity of AW bracket locking hood/housings in place. Attach the governor bracket housing in similar manner, and proceed to tighten all remaining hood screws. Remove the temporary flame baffle props, making sure only the fusible tab holds the baffle in its upper position.

Proceed to attach the back hood to the hood straps. Align and punch all holes in the back hood at the points where holes are provided in the hood straps.

#### HOODS, SUPPORTS & HOUSINGS (ABOVE LINTEL):

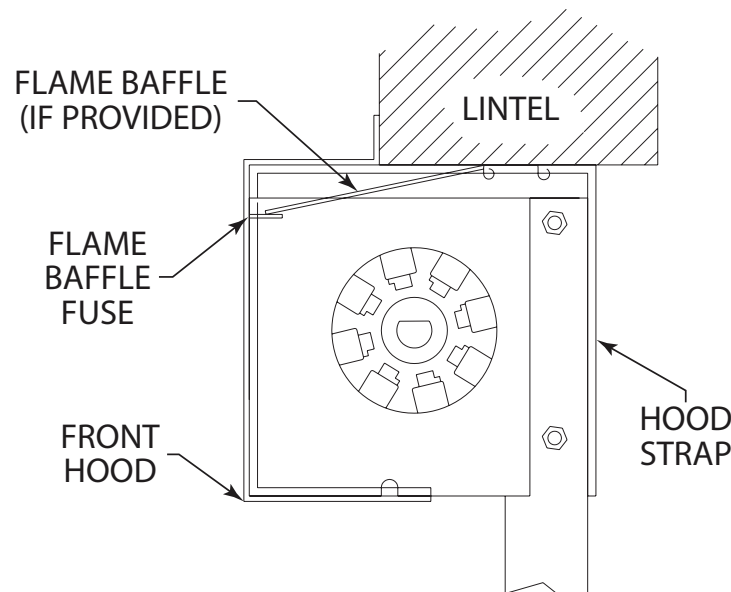
**NOTE:** Lower the shutter to offer the maximum clearance between the coil and the lintel.

**IMPORTANT:** The front hood may contain a flame baffle fusible tab located inside. The flame baffle (if provided) must reset above this tab and be contained by it (see **Figure 29**).

Fasten the hood to the existing holes in the bracket flanges using the self-tapping screws provided. DO NOT tighten screws at this time, since the housings must slide under the front hood.

Refer to **Figure 30**. Depending on the width of the hood, extra supports may be required. If hood straps are provided, erect them now. To allow for thermal expansion, locate the connecting screws in the bottom of the slots.

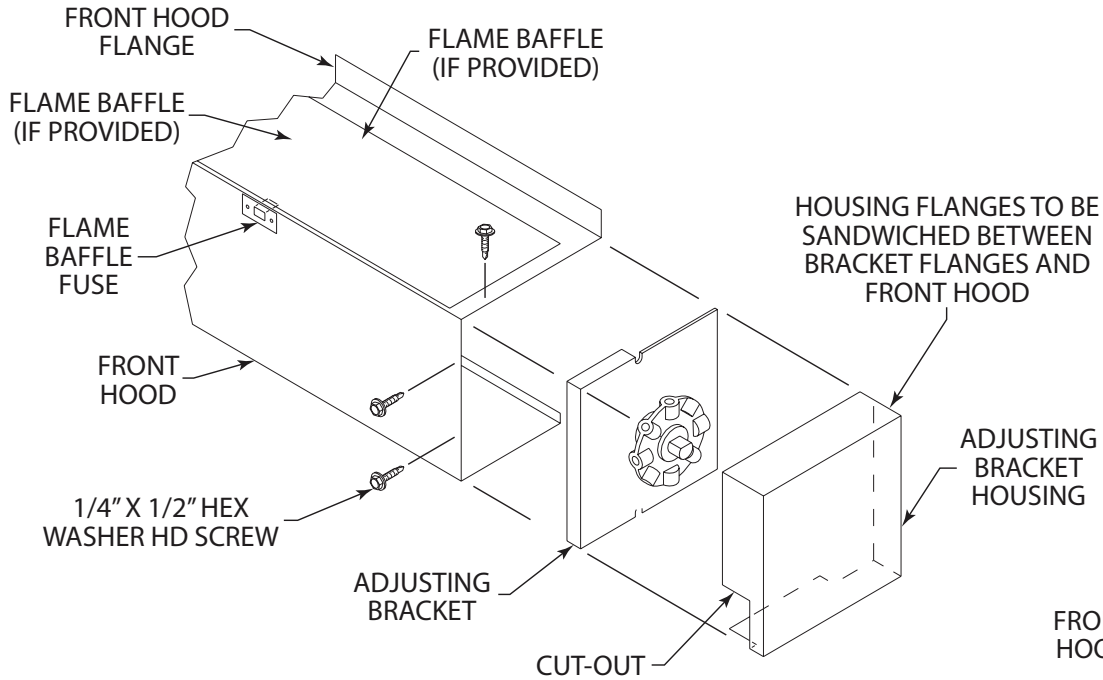
Attach the A.W. bracket housing and sandwich housing flange between bracket flange and front hood (see **Figure 29**). Check to insure the cut-outs, as provided, are large enough so as not to interfere with either drop arm throughout its travel. Trim if necessary. Now tighten all screws in the vicinity of A.W. bracket. Attach the governor bracket housing in similar manner and proceed to tighten all remaining hood screws.



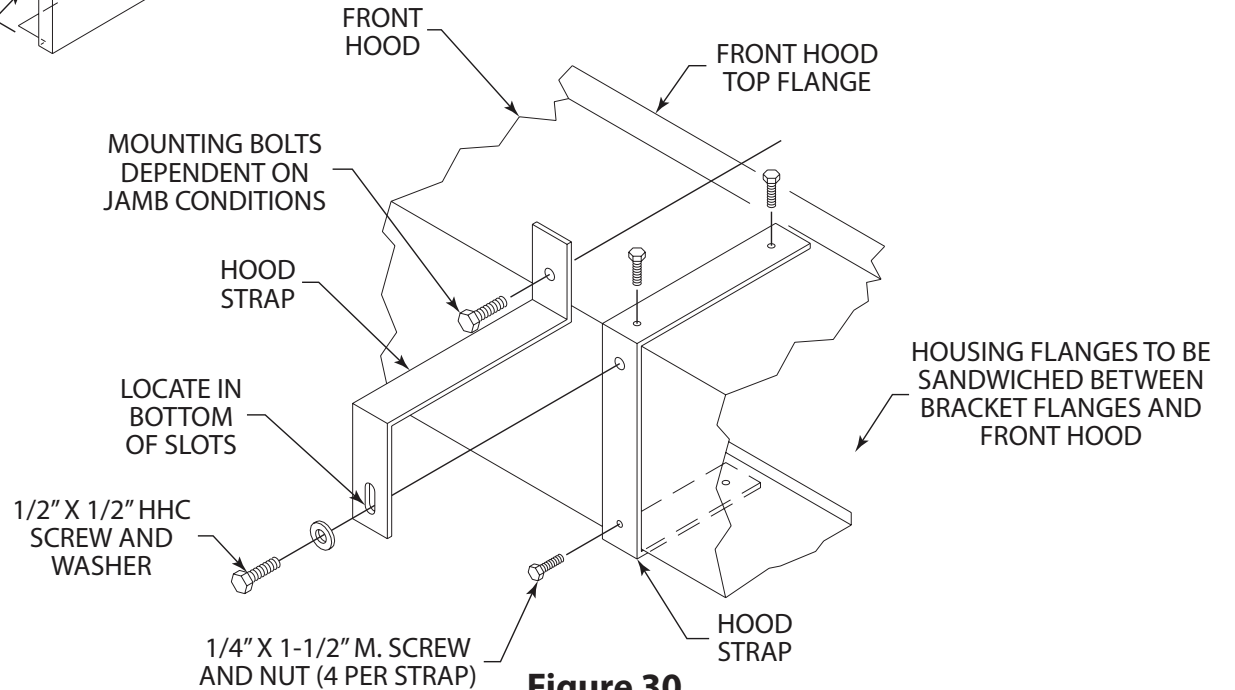
**Figure 28**

# SECTION 5 - DOOR INSTALLATION CONTINUED...

## STEP 15 HOODS, SUPPORTS AND HOUSINGS (UNDER LINTEL) CONTINUED...



**Figure 29**



**Figure 30**

# SECTION 5 - DOOR INSTALLATION CONTINUED...

## STEP 16 MISCELLANEOUS FINAL CHECKLIST

Check the area for any extra parts, and be sure these were not omitted in the installation process.

Recheck all bolted connections to verify all are securely tightened.

Clean up the area and make sure it is secure, with the handle engaged with the pin provided.

If the building owner or facility manager is unfamiliar with the product, demonstrate the operation of the door and any optional equipment before leaving the job site. Be sure to demonstrate how to safely drop test the door and point out the importance of Pad-Locking the release handle to avoid possible tampering. Have the customer or his representative sign off on the installation using the "Rolling Fire Door Test Drop Release Form" provided in the hardware bag and also fill out the "Test Drop Release Form" in the back of this manual. Return a copy of form in the hardware bag to Wayne Dalton™ and keep a copy in your maintenance files. Exchange all documentation and keys to locks at this time. Be sure the customer receives a copy of this manual and of the installation drawing.

Be sure to report (in writing) to the factory any complaints or recommendations the customer may register at the completion of the installation that may have a bearing on future designs.

**IMPORTANT:** Warning label must be applied to operated side of the rolling door, on the guide, at eye level.


<b>WARNING</b>
Fire Door May Close Rapidly at ANY TIME and cause serious injury or death. Do NOT stand doorway in doorway.
<b>SAFETY INSTRUCTIONS</b>
<ol style="list-style-type: none"><li>1. Do not block opening or wedge door open. • Conditions that prevent normal or emergency operation must be corrected immediately. • Repair parts must be obtained from doors manufacturer per NFPA80.</li><li>2. Door is under extreme spring tension. Adjustments must be made while door is fully open. Repairs and adjustments must be made by an experienced door professional using proper tools and instructions.</li><li>3. Inspect and drop test door periodically, as shown below (See Testing).</li></ol>
<b>AKBAR 89™ / ALTER® MAINTENANCE</b>
DETAILED MAINTENANCE INSTRUCTIONS MAY BE FOUND IN THE INSTALLATION INSTRUCTIONS PROVIDED WITH EACH ORDER.
<b>INSPECTION:</b> Visually inspect door every two weeks for cleanliness and ease of operation. Check for damage and wear. Damage to the hood or guide may prevent door closing during fire. Tighten bolts wherever needed. <b>CLEANING:</b> Clean as needed in accordance with good housekeeping practices. <b>PAINTING:</b> Clean thoroughly with commercial solvents before painting. <b>CAUTION:</b> Allow paint to dry thoroughly with door in the closed position. <b>LUBRICATION:</b> Necessary only when accumulated dirt and grime are removed. Re-grease lightly. Gear and hoist shafts should be lubricated with machine oil. <b>TESTING:</b> Drop test and rest release mechanism annually as required by NFPA80 and building codes. Drop test must be made while fire door is fully open. Damage may occur if fire door is closed when automatic mechanism is released. Follow installation instructions for drop testing and resetting release mechanism. Testing and resetting of release mechanism must be performed by qualified personnel.
Place label at a readable height on door drive side guide or jamb. Do NOT remove, cover, or paint over label. This label should be inspected periodically for legibility, and a replacement label should be ordered from the door manufacturer as needed.
 273490 REV1 05/11/2026

Wayne Dalton™  
Rolling Door Division  
14512 Lincolnway St E  
Dalton, Ohio 44618

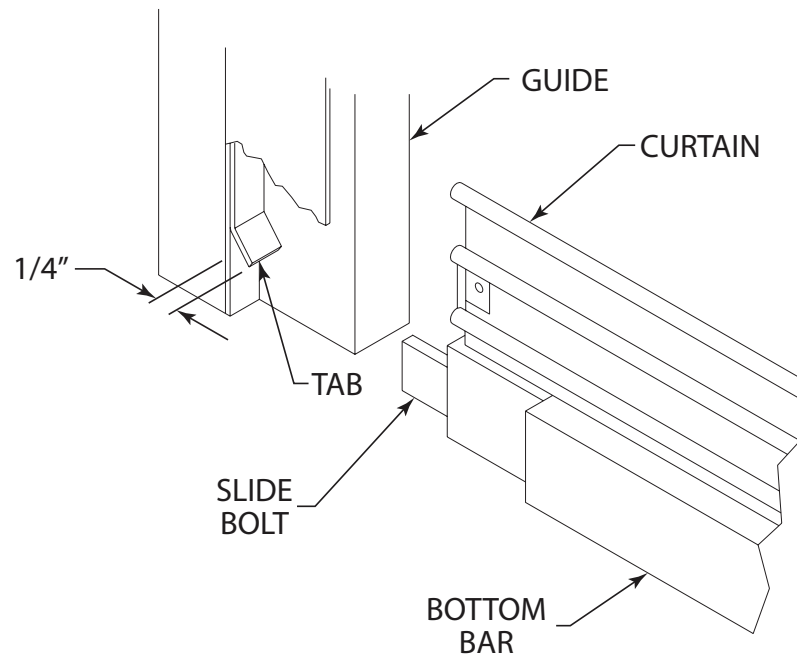
# APPENDIX A - OPTIONAL COMPONENTS

## MISCELLANEOUS FINAL CHECKLIST

The following are some examples of common options and adjustments for fire shutters:

### SLIDE BOLTS OR CYLINDER LOCKS

Raise the shutter to the open position. Bend the tab on the inside of the guides so that it sticks out about 1/4". Lower the shutter and try to engage the locks. If the bottom bar contacts the tab before the door is completely closed, or the locks still do not engage the tab, bend the tab back in so that the casting just clears.



**Figure 31**



# APPENDIX C - TROUBLESHOOTING

## WARNING

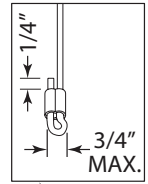
**ALL REPAIRS, ADJUSTMENTS AND MAINTENANCE MUST BE DONE BY A TRAINED ROLLING FIRE DOOR SYSTEMS TECHNICIAN.**

The chart below is a list of possible problems with the operation of the fire shutter. The probable causes listed are the most common, and are not meant to include ALL possibilities. With the variety of the product and the field conditions, other factors may be involved.

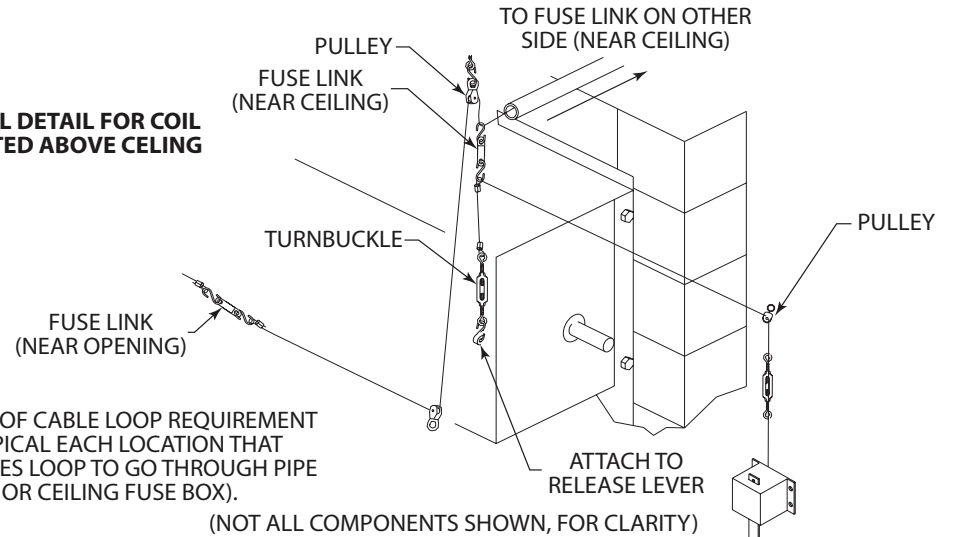
# APPENDIX D - ADDITIONAL FUSIBLE LINK CABLING

Below are additional details for fire shutters with the coil mounted above ceiling, or a typical modification for electro-mechanical release devices. These are provided as a sample and may not be right for every installation. The actual field condition at the job site will determine the best cable routings. If you need help determining a cable routing for your installation contact Wayne Dalton™ Technical Service for assistance.

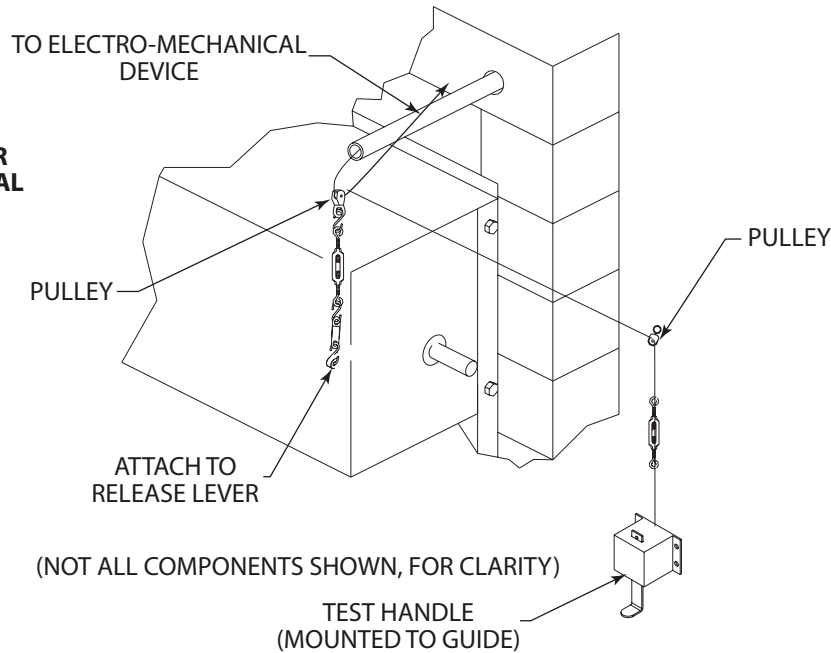
**TYPICAL DETAIL FOR COIL MOUNTED ABOVE CEILING**



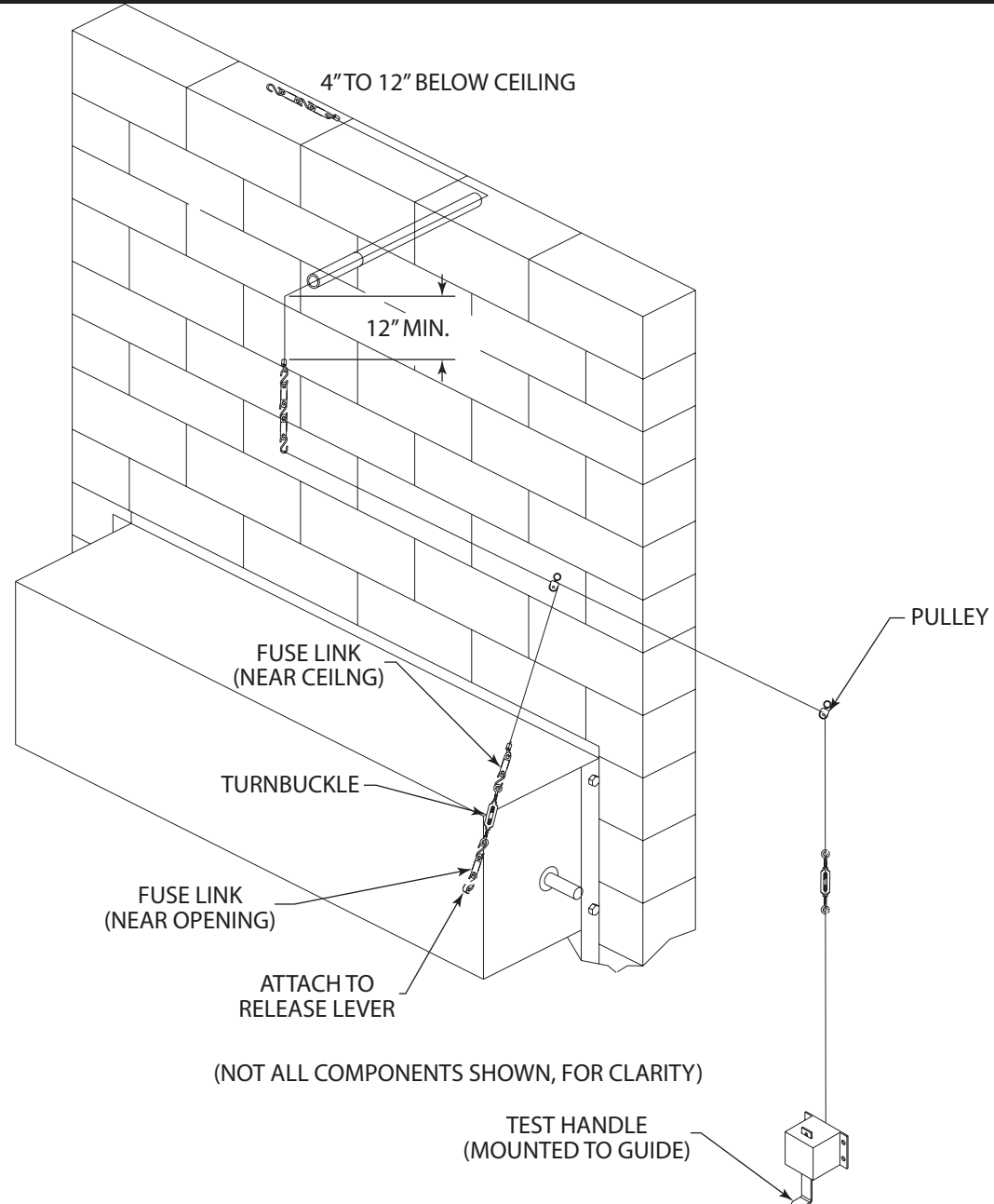
DETAIL OF CABLE LOOP REQUIREMENT  
(TYPICAL EACH LOCATION THAT  
REQUIRES LOOP TO GO THROUGH PIPE  
OR CEILING FUSE BOX).



**TYPICAL DETAIL FOR ELECTRO-MECHANICAL DEVICES**



# APPENDIX D - ADDITIONAL FUSIBLE LINK CABLING CONTINUED...



# APPENDIX E - DROP TESTS AND ANNUAL INSPECTION

## Appendix E: Drop Tests and Annual Inspection.

Wayne Dalton Provides a 3 part form titled Rolling Door Drop Test Form and Annual Inspection. This form provides guidelines for inspecting and testing fire products. The form also provides space to record each test and inspection that occurs. The guidelines provided may be incomplete for some installations. A sample of the form is provided. If you did not receive a form or need more forms contact your Wayne-Dalton Customer Service Representative. The part number of this form is 101-0079-04.

WAYNE-DALTON  
ROLLING FIRE DOOR DROP TEST FORM  
AND ANNUAL INSPECTION

NOTE TO OWNER: NFPA-80 requires the annual testing of rolling fire doors to demonstrate proper and full closure. Resetting of the release mechanism must be done in accordance with the manufacturer's instructions. A written record must be maintained and made available to the authority having jurisdiction. NFPA-80 also requires that when damage impairs the door's proper emergency function, that it be repaired with parts obtained from the original door's manufacturer and upon completion of repairs that the door be tested to assure emergency operation and closing.

**WARNING: SEVERE INJURY OR DEATH MAY RESULT THROUGH IMPROPER ATTEMPTS AT DROP TESTING, REPAIR AND/OR MAINTENANCE.**

Drop testing, repair and/or maintenance should be performed by qualified personnel with a complete knowledge and understanding of this type of door. Before drop testing, conduct a visual inspection for damaged or missing parts that may create a hazard during testing or affect proper operation or resetting. Verify proper installation. Open and close the door to check for correct spring tension. **ADDITIONAL INFORMATION ON DROP TESTING IS PROVIDED ON THE REVERSE SIDE OF THIS FORM. IN THE MANUFACTURER'S INSTALLATION/RESET INSTRUCTIONS, AND IN NFPA-80.**

PROJECT \_\_\_\_\_ CONTACT PERSON \_\_\_\_\_  
 ADDRESS \_\_\_\_\_ PHONE \_\_\_\_\_  
 \_\_\_\_\_ DATE \_\_\_\_\_

Door # Location	Door Size	Door Serial No.	U.L. Tag No.	Visual Check		Operation Check		Visual check	
				Pass	Fail	Pass	Fail	Pass	Fail
1.									
2.									
3.									
4.									

New Installation \_\_\_\_\_ Annual Check \_\_\_\_\_

COMMENTS AND RECOMMENDED WORK (new form needed when work is completed)

Door #1 \_\_\_\_\_  
 Door #2 \_\_\_\_\_  
 Door #3 \_\_\_\_\_  
 Door #4 \_\_\_\_\_

The doors listed above (noted as "passed" for the drop test) have been installed in accordance with the manufacturer's installation instructions. The automatic release device has been tested to demonstrate proper operation and full closure. They have been reset in accordance with the manufacturer's reset instructions and left in proper working condition, unless otherwise noted above.

TESTED BY \_\_\_\_\_ WITNESSED BY \_\_\_\_\_  
 COMPANY \_\_\_\_\_ REPRESENTING \_\_\_\_\_  
 ADDRESS \_\_\_\_\_ SIGNATURE \_\_\_\_\_  
 \_\_\_\_\_ RECOMMENDED WORK IS: Authorized \_\_\_\_\_ Declined \_\_\_\_\_  
 SIGNATURE \_\_\_\_\_ DATE \_\_\_\_\_  
 BY \_\_\_\_\_

SUGGESTED INSPECTION AND DROP TEST GUIDELINE ON REVERSE SIDE

# APPENDIX E - DROP TESTS AND ANNUAL INSPECTION CONTINUED...

## INSPECTION AND DROP TEST GUIDELINES

Refer to the manufacturer's installation/reset instructions and NFPA-80.

### VISUAL INSPECTION:

## ⚠ CAUTION

**EVERY COMPONENT OF A DOOR AND ITS INSTALLATION MUST BE CHECKED FOR DETERMINATION OF FACTORS THAT MAY AFFECT A DOOR'S INTENDED OPERATION AND PERFORMANCE. THE LIST BELOW MAY BE INCOMPLETE AND IS PROVIDED AS A GUIDELINE ONLY.**

### A. PROPER INSTALLATION REQUIREMENTS

1. Curtain, barrel and guides must be aligned level, plumb, and true.
2. Attachment to jambs must be with proper bolts, expansion anchors, or as otherwise required by the listing.
3. Maintain expansion clearance (top of guides for FireStar® Fire Shutter)
4. Fusible links must be located at top of door and within 1 foot of ceiling on both sides of wall.

### B. CHECK AND REPAIR DAMAGED, INCORRECT OR MISSING PARTS, SUCH AS:

1. Slats - bent slats, cracked beads, torn ends.
2. Endlocks - missing, broken, bent, loose.
3. Bottom bar - bent angles, loose bolts, missing washers on bolts (when required).
4. Guide assembly - bent angles, loose bolts, missing galvanized washers or bolts (when required) Curtain entry or debris in guide.
5. Hood and flame baffle (when baffle required) - bent, rubbing curtain in open position, holes, tears. Attachment to brackets and wall (when required), intermediate supports (when required).
6. Brackets and operating mechanisms - worn, misaligned or badly meshed gears, sprockets or chains, broken parts, and bent shafts.
7. Automatic closing and governor mechanisms - missing or broken parts, drop or release arms tied, blocked, or wedged.
8. Fusible links, cable, S-hooks, eyes, pulleys, etc. - links painted or coated with dust or grease, kinked or pinched cable, twisted or not flexible, obstructed eyes or raceways.
9. Mounting and assembly bolts - missing or loose
10. Guide mounting bolts must all be in top of slot for upward expanding FireStar® fire shutters.
11. Past replacement of parts not from the original door manufacturer - "homemade" or mismatched parts are not approved and must be replaced.

12. Check balance and spring tension of door

13. If chain operated, check hand chain for damaged links. Replace or repair if necessary.

14. If motor operated, check door operating jamb sprocket and chain, adjust and lubricate as necessary. Readjust limits as necessary.

### C. ANCILLARY EQUIPMENT

1. Smoke detectors/release devices - check continuity (all release devices must be tested).
2. Control panels - check function.
3. Miscellaneous other equipment should be checked for proper function and operation.

## ⚠ WARNING

**SERVICING OF MOTOR OPERATOR SHOULD BE DONE BY A QUALIFIED ELECTRICIAN WITH THE NECESSARY SCHEMATICS AND PROPER KNOWLEDGE OF THE OPERATOR.**

### OPERATIONAL INSPECTION

Roll door up and down in normal operation to check for spring tension and free movement of curtain in guides.

### DROP TEST

If the shutter does not roll up and down properly in normal operation, or if there are damaged or missing parts that will create a hazard or prevent proper operation or reset, THESE CONDITIONS MUST BE CORRECTED BEFORE CONDUCTING A DROP TEST.

Drop test per manufacturer's instructions. Drop test should provide for automatic closing of the curtain at an average speed not less than 6 inches per second, nor more than 24 inches per second, and full closure of the curtain with the bottom bar closing evenly across the sill/floor.

Reset per manufacturer's instruction. Complete drop test forms and forward copies to Wayne Dalton™ dealer and customers.

ULTIMATE ACCEPTABILITY OF A FIRE DOOR IS THE DECISION OF THE AUTHORITY HAVING JURISDICTION, AS DEFINED BY NFPA-80.



# FireStar® Fire-Rated Counter Shutter Limited Warranty

Wayne Dalton, a division of Overhead Door Corporation ("Seller") warrants to the original purchaser of the FireStar® Fire-Rate Counter Shutter ("Product"), subject to all of the terms and conditions hereof, that the Product and all components thereof will be free from defects in materials and workmanship for the following period(s) of time, measured from the date of installation:

- **24 MONTHS** against defects in materials and workmanship

Seller's obligation under this warranty is specifically limited to repairing or replacing, at its option, any part which is determined by Seller to be defective during the applicable warranty period. Any labor charges are excluded and will be the responsibility of the purchaser.

This warranty is made to the original purchaser of the Product only, and is not transferable or assignable. This warranty does not apply to any unauthorized alteration or repair of the Product, or to any Product or component which has been damaged or deteriorated due to misuse, neglect, accident, failure to provide necessary maintenance, normal wear and tear, acts of God, or any other cause beyond the reasonable control of Seller or as a result of having been exposed to toxic or abrasive environments, including blowing sand, salt water, salt spray and toxic chemicals and fumes.

**THIS WARRANTY IS EXCLUSIVE AND IN LIEU OF ANY OTHER WARRANTIES, EITHER EXPRESS OR IMPLIED, INCLUDING BUT NOT LIMITED TO ANY IMPLIED WARRANTY OF MERCHANTABILITY OR FITNESS FOR A PARTICULAR PURPOSE.**

**IN NO EVENT SHALL SELLER BE RESPONSIBLE FOR, OR LIABLE TO ANYONE FOR, SPECIAL, INDIRECT, COLLATERAL, PUNITIVE, INCIDENTAL OR CONSEQUENTIAL DAMAGES, even if Seller has been advised of the possibility of such damages. Such excluded damages include, but are not limited to, loss of use, cost of any substitute product, or other similar indirect financial loss.**

Claims under this warranty must be made promptly after discovery, within the applicable warranty period, and in writing to the authorized dealer or installer whose name and address appear below. The purchaser must allow Seller a reasonable opportunity to inspect any Product claimed to be defective prior to removal or any alteration of its condition. Proof of the purchase and/or installation date, and identification as the original purchaser, may be required.

SELLER: \_\_\_\_\_

SELLER'S ADDRESS: \_\_\_\_\_

\_\_\_\_\_