

INSTALLATION INSTRUCTIONS AND OWNER'S MANUAL

FireStar[®], Models 700, 700C

ROLLING FIRE DOOR

**PLEASE DO NOT RETURN THIS PRODUCT TO
THE STORE**

If you need assistance, please call 1-866-569-3799 (Press Option 1) and follow the prompts to contact a customer service representative. They will be happy to handle any questions that you may have.

IMPORTANT NOTICES!

To avoid possible injury, read and fully understand the enclosed instructions carefully before installing and operating the garage door. Pay close attention to all warnings and notes. After installation is complete, fasten this manual near garage door for easy reference.

This Installation document is available at no charge from:

- Your local Wayne Dalton Sales Center, or
- Online at **www.Wayne-Dalton.com**, or
- By mailing to: Wayne Dalton, a division of Overhead Door Corporation, P.O. Box 67, Mt. Hope, OH., 44660

Table Of Contents

PRE-INSTALLATION	3
Important Safety Instructions	3
Tools Required	3
Package Contents	4
Introduction	4
Preparations	4
Material	4
Clearances	4
Removing an Existing Door	5
PARTS BREAKDOWN	6
INSTALLATION	7
WARRANTY	21

Important Safety Instructions

DEFINITION OF KEY WORDS USED IN THIS MANUAL:



INDICATES A POTENTIALLY HAZARDOUS SITUATION WHICH; IF NOT AVOIDED, COULD RESULT IN SEVERE OR FATAL INJURY.



INDICATES A HAZARDOUS SITUATION

IMPORTANT: Required key step for proper door operation.

NOTE: Information assuring proper installation of the door.

HINT: Indicates a suggested step to simplify installation based on experience.

READ THESE INSTRUCTIONS CAREFULLY BEFORE ATTEMPTING INSTALLATION. IF IN QUESTION ABOUT ANY OF THE PROCEDURES, DO NOT PERFORM THE WORK. INSTEAD, HAVE A TRAINED DOOR SYSTEMS TECHNICIAN DO THE INSTALLATION OR REPAIRS.

1. **READ AND FOLLOW ALL INSTALLATION INSTRUCTIONS.**
2. Wear protective gloves during installation to avoid possible cuts from sharp metal edges.
3. It is always recommended to wear eye protection when using tools, otherwise eye injury could result.
4. Installation MUST comply fully with ALL provisions of NFPA 80 regulations and final approval must be obtained from the authority having jurisdiction. This is the installer's responsibility.
5. These doors are under-balanced. Removing the roller chain from a motor operated door or tampering with the chain hoist unit on a manually operated door while the door is partially or fully open, will cause the door to freefall. This may result in severe or fatal injury.
6. Avoid installing your new door on windy days. Door could fall during the installation causing severe or fatal injury.
7. Doors 12'-0" wide and over should be installed by two persons, to avoid possible injury.
8. Operate door only when it is properly adjusted and free from obstructions.
9. If a door becomes hard to operate, inoperative or is damaged, immediately have necessary adjustments and/ or repairs made by a trained door system technician using proper tools and instructions.
10. DO NOT stand or walk under a moving door, or permit anybody to stand or walk under an electrically operated door.
11. DO NOT place fingers or hands in between curtain & guides while door is moving.
12. DO NOT permit children to operate garage door or door controls. Severe or fatal injury could result should the child become entrapped between the door and the floor.
13. Due to constant extreme spring tension, do not attempt any adjustment, repair or alteration to any part of the door, especially to springs, spring brackets, bottom corner brackets, fasteners, counterbalance lift cables or supports. To avoid possible severe or fatal injury, have any such work performed by a trained door systems technician using proper tools and instructions.
14. On electrically operated doors, pull down ropes must be removed and locks must be removed or made inoperative in the open (unlocked) position.
15. Top section of door may need to be reinforced when attaching an electric opener. Check door and/ or opener manufacturer's instructions.

16. Visually inspect door and hardware monthly for worn and or broken parts. Check to ensure door operates freely. Also check to ensure all bolted connections to insure they are secure.
17. Test electric opener's safety features monthly, following opener manufacturer's instructions.
18. This door may not meet the building code wind load requirements in your area. For your safety, you will need to check with your local building official for wind load code requirements and building permit information.
19. This manual is NOT intended to provide "take-down" instructions for existing door. Consult your local Wayne-Dalton dealer if existing door needs to be removed.
20. Thoroughly familiarize yourself with the construction codes in your region before initiating work.
21. If the building design and door installation create potential pinch points to users, owner is responsible for the installation of appropriate guarding, in compliance with OSHA regulations.
22. Consider using a multi-person crew for installing, adjusting and/or repairing larger doors.

After installation is complete, fasten this manual near the garage door.

IMPORTANT: Right hand and left hand is always determined from inside the building looking out.



PRIOR TO WINDING OR MAKING ADJUSTMENTS TO THE SPRINGS, ENSURE YOU'RE WINDING IN THE PROPER DIRECTION AS STATED IN THE INSTALLATION INSTRUCTIONS. OTHERWISE, THE SPRING FITTINGS MAY RELEASE FROM SPRING IF NOT WOUND IN THE PROPER DIRECTION AND COULD RESULT IN SEVERE OR FATAL INJURY.

IMPORTANT: Right and left hand is always determined from inside the building looking out.

Tools Required

Power drill w/3/8" or 1/2" chuck	Two hardened steel bars w/knurled ends, 1/2" diameter and approximately 18" long, or 3/4" diameter x 24", or 7/8" diameter x 24" (dependent upon door size)	Step Ladder
Masonry drill or impact hammer and bits	Wrenches	Level and String level
Chain hoist	Screwdrivers	Chalk line
Ladders and/or scaffolding	Drills	Plumb line
Two 3/4" diameter steel rods 24" long for checking and correcting guide openings.	Center punch	Vice grips or C-clamps
Electric impact drill with 1/2" chuck.	Water-level hose	Leather gloves
Cable cutters and diagonal cutters	Hammer	Safety glasses
	Tape measure	

Package Contents

NOTE: Depending on the door model, some parts listed will not be supplied if not required. Rear Back Hangs may not be included with your door.

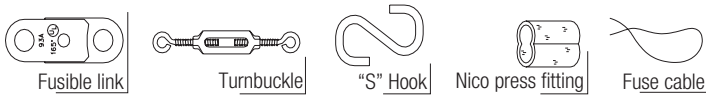
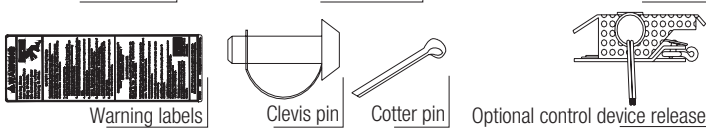
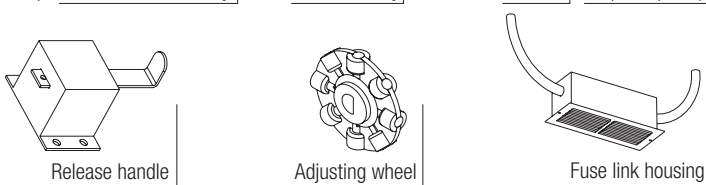
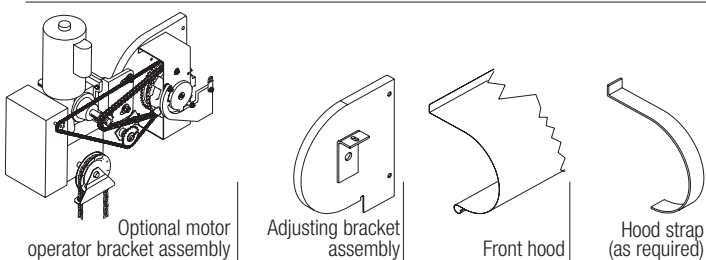
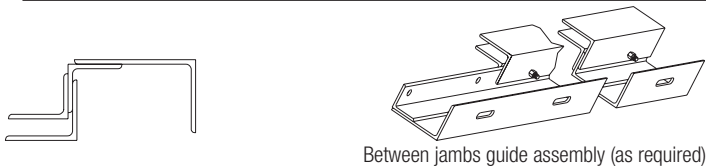
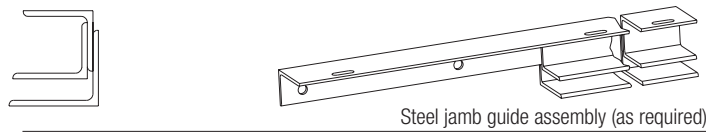
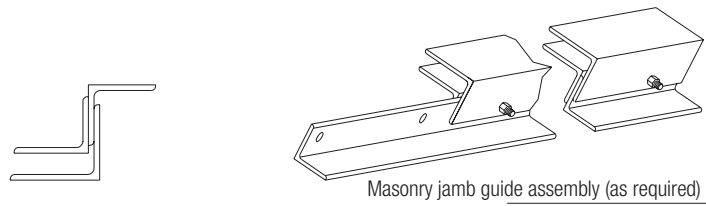
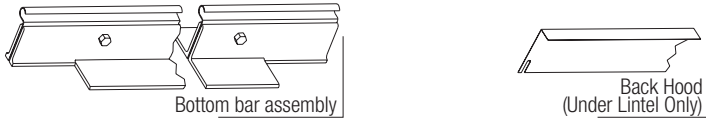
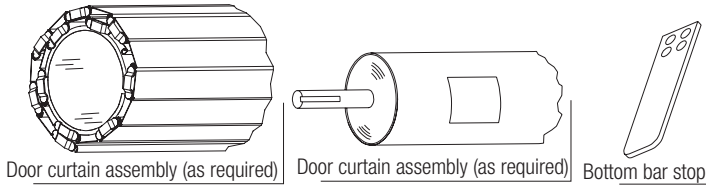

Quantity	Part #	Description	Where Used
2	807-0171-04	Cotter pins - 3/16" x 1-1/2"	AW and drive side
6	801-0350-05	1/2" - 13 x 1-1/2" HH Cap screws	Brackets to guides

Quantity	Part #	Description	Where Used
6	802-0004-05	1/2" - 13 Hex nuts	Brackets to guides
18	805-0100-04	3/8" x 3-3/4" Stud anchors	Guides to wall
5	801-1070-05	1/4" - 20 x 1-1/2" RHMS	Hood to wall
5	805-0129-04	1/4" x 1" Expansion shields	Hood to wall
5	804-0002-05	1/4" Flat washers	Hood to wall
10	803-1807-05	1/4" x 1/2" Self-tapping screws	Hood to brackets / straps
4	801-2808-05	3/8" - 16 x 3/4" Hex HD Grade 5	4
10	801-0274-05	5/16" - 18 x 1" HHCS	Top slat to ring
10	802-0031-05	5/16" - 18 Square nuts	Top slat to ring
10	804-0025-05	5/16" Flat washers	Top slat to ring
1	806-0071-05	Rivet, Rnd Hd, 1/2" x 1-3/4"	AW to bracket

Introduction

The main function of this manual is to assist the installer in correctly installing FireStar® Rolling Steel Fire Doors with due regard for safety, operation, and sound construction practices. NFPA 80 and local fire and building codes take precedence over any discrepancies with these installation instructions.

All Wayne Dalton FireStar® Rolling Steel Fire Doors follow the general installation instructions outlined in this manual. Additional installation information for each specific door shipped is found on drawings and parts lists in the hardware bag.

Preparations

READ THE INSTALLATION INSTRUCTIONS CAREFULLY TO BECOME FAMILIAR WITH THE NAMES OF THE VARIOUS COMPONENTS AND THEIR RELATIONSHIP TO EACH OTHER. IT IS ESSENTIAL FOR THE INSTALLER TO DETERMINE THE FOLLOWING:

- The type of mounting to be employed (face of wall or between jambs)
- Right or left hand operation as determined from the coil side.
- Type of jamb material on site and the proper fasteners for that material.
- The opening width, opening height, head room, and side room dimensions.

Material

Inspect all doors and components for possible damage or shortage of parts, prior to leaving for the job site. Immediately report any shortages to your Wayne Dalton customer service representatives and any shipping related damage to the shipping company.

Clearances

The installation drawings, supplied in the hardware bag, contain dimensional information regarding bracket size, head room, and side room requirements for each specific door. Be sure that the opening you are working on matches those dimensions. Take special note of the "C" dimension. **THE "C" DIMENSION MUST BE HELD** to ensure proper door operation. Prior to starting the installation, be sure the required clearances are available.

Removing an Existing Door

IMPORTANT: Counterbalance spring tension must always be released before any attempt is made to start removing an existing door.



A POWERFUL SPRING RELEASING ITS ENERGY SUDDENLY CAN CAUSE SEVERE OR FATAL INJURY. TO AVOID INJURY, HAVE A TRAINED DOOR SYSTEMS TECHNICIAN, USING PROPER TOOLS AND INSTRUCTIONS, RELEASE THE SPRING TENSION.

PARTS BREAKDOWN

NOTE: The illustrations shown on this page are general representations of the door parts. Each specific door model may have unique variations.

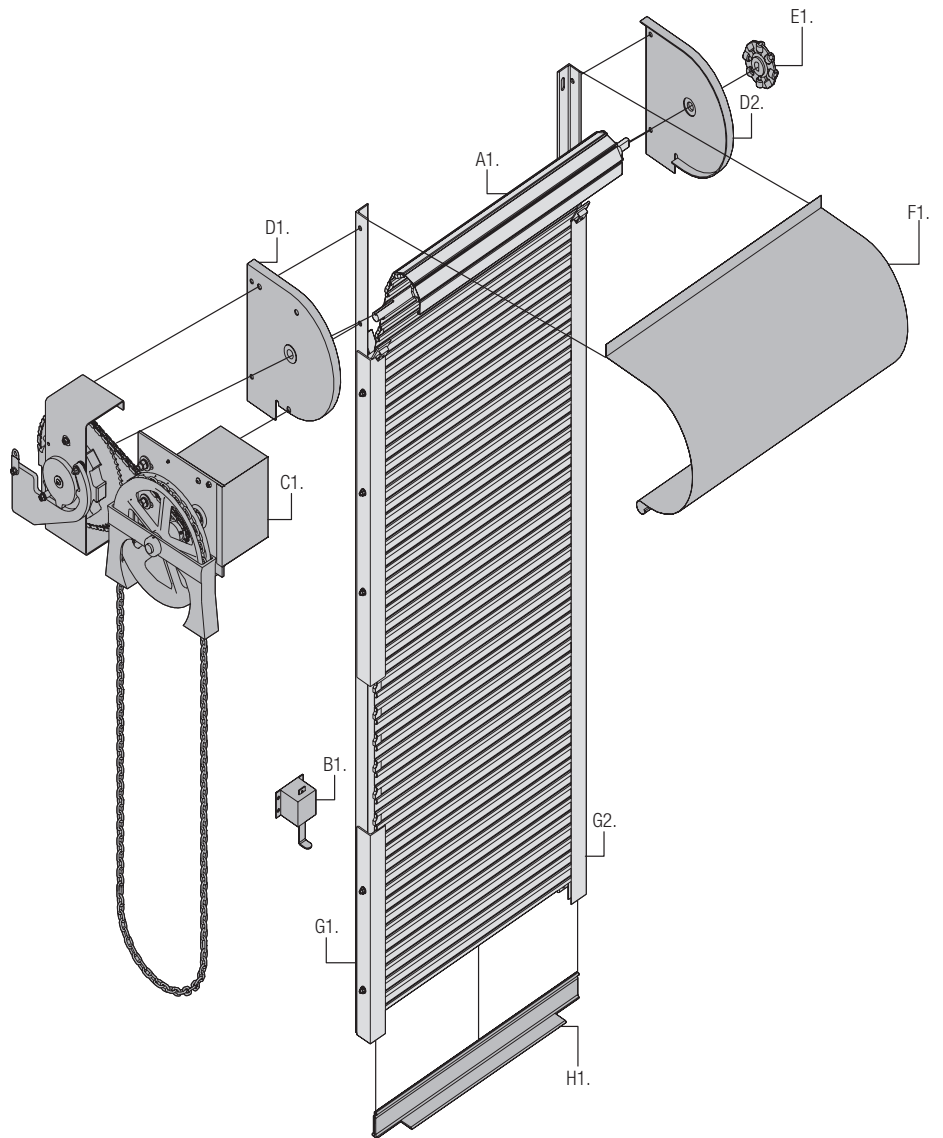

A. CURTAIN:

A1. Curtain Assembly

B. RELEASE HANDLE:

B1. Release Handle

C. CHAIN HOIST:

C1. Standard Chain Hoist Mechanism

D. BRACKETS:

D1. Left Hand Bracket

D2. Right Hand Bracket

E. ADJUSTING WHEEL:

E1. Adjusting Wheel

F. FRONT HOOD:

F1. Hood

G. GUIDES:

G1. Left Hand Guide Assembly

G2. Right Hand Guide Assembly

H. BOTTOM BAR:

H1. Bottom Bar Assembly

INSTALLATION

Before installing your door, be certain that you have read and followed all of the instructions covered in the pre-installation section of this manual. Failure to do so may result in an improperly installed door.

NOTE: Reference TDS 160 for general garage door terminology at www.dasma.com.

1 OPENING CHECKS

Check the opening width "A" and the opening height "B" or "F" and compare with the installation drawing to be sure the opening is the proper size for the door. Any variation in the actual opening width or height, or plumb of the jambs is to be disregarded when installing the guides. Verify the clearances available meet or exceed those given on the installation drawing.

Unpack and lay out all door components (prior to leaving for the job site, if possible) and review the following:

1. Does barrel hand of operation match the required hand on the drawings?
2. Do guide mounting angles match the required arrangement for masonry or steel?
3. Are all "extras" included such as safety edge, weather stripping, etc.

If **no** is the answer to any of these questions, stop and check with the factory for clarification before proceeding.

NOTE: Rope off the opening prior to beginning work!

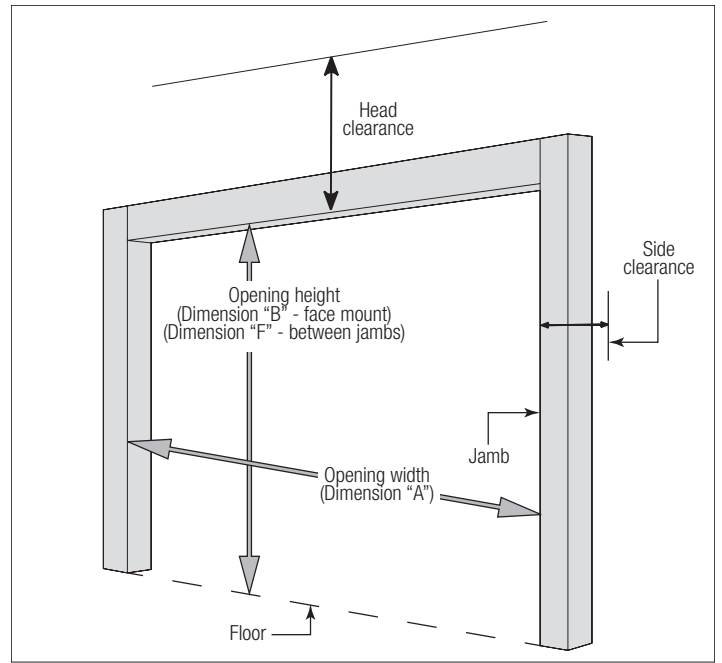
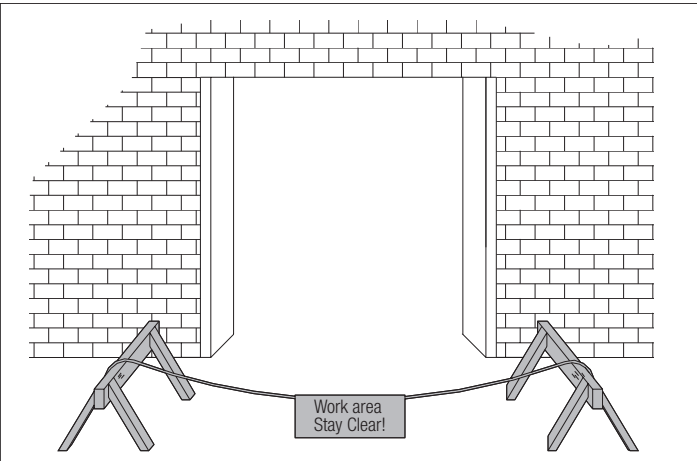

2 GUIDE MOUNTING

FACE MOUNTED DOORS:

Record the "C" dimension from the installation drawing on the line provided below. Measure the distance from the inside of the left guide to the centerline of the slots on the wall angle ("M") and record. Repeat for the right guide. On masonry jambs (with mounting leg out as shown, or "Z" guides), add the "C" dimension and the recorded dimensions ("M") to obtain a "bolt line" dimension (for steel jambs, or "E" guides, subtract).

"C" Dimension (from Dwg.) _____

"M" (Left Guide) _____

"M" (Right Guide) _____

(+ Masonry jamb; - Steel jamb)

Bolt Line _____

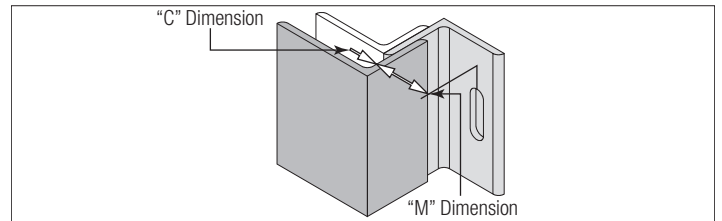

Center the bolt line dimension in the opening and make a mark on one jamb at the top. Drop a plumb line down and make a second mark on the wall at the bottom. Using a chalk line, make a vertical line the length of the "F" dimension, passing through both marks. Measure "BL" horizontally onto the other jamb and repeat the process.

Measure from the bottom of the mounting angle to the bolt centerline at the bottom of the first slot. Add the expansion clearance (found on the installation drawing) to this dimension and mark that point on the wall.

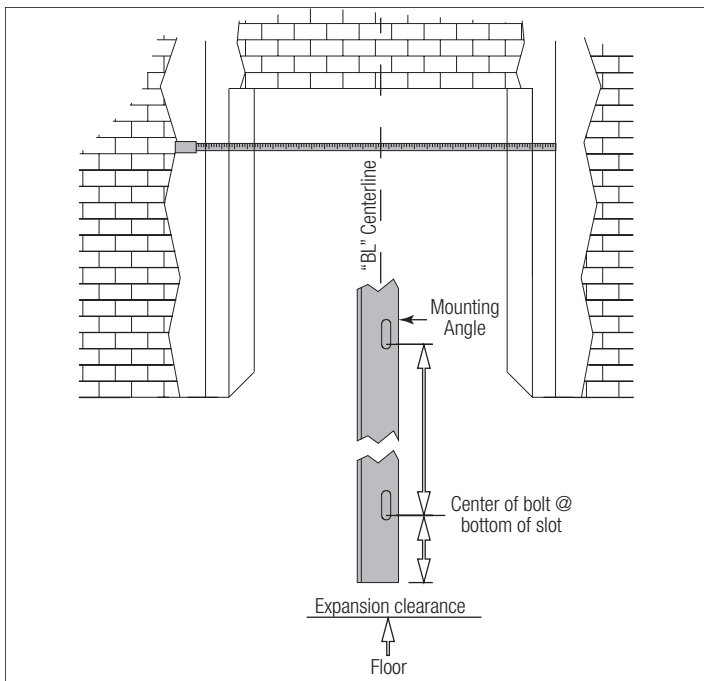

NOTE: If floor is not level, make a mark on the jamb where floor is highest.

Using a string level, mark the other jamb at the same height. Measure from this point to the bolt centerline at the bottom of the next slot up on the mounting angle. Repeat this process for the remaining holes.

NOTE: If any fasteners, other than the ones supplied are used, they must be on the approved substitution list in NFPA 80 and cannot be of a lesser grade or diameter.

WARNING

GUIDE ASSEMBLIES ARE EXTREMELY HEAVY. TO AVOID POSSIBLE INJURY, PERSONS WITH LIFTING LIMITATIONS SHOULD NOT PERFORM THIS NEXT STEP.

Stand up the guide assembly against the wall and install the top and bottom bolts in the slots provided. **Bolts must be installed at the bottom of all slots.** Repeat for other jamb.

IMPORTANT: The galvanized washers must be installed to ensure proper guide expansion in event of fire.

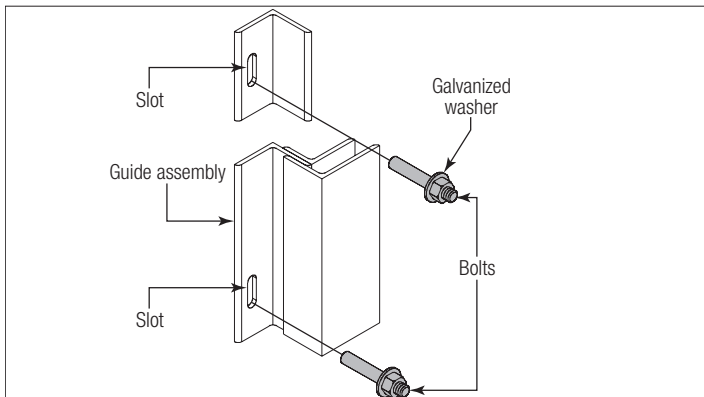

IMPORTANT: Fire doors will tend to expand downward. It is necessary to set the guides off the floor the required expansion clearance per the installation drawing provided and install the guide bolts at the bottom of slots.

Using a string and a level, ensure that the guides are parallel to each other. Shim at the wall as required. Place the level on both guides. Now install the remaining bolts (for welding of guides see Alternate Welding of Guides to Steel section). Install the back bottom bar stops now (see Bottom Bar Stop Installation Section)

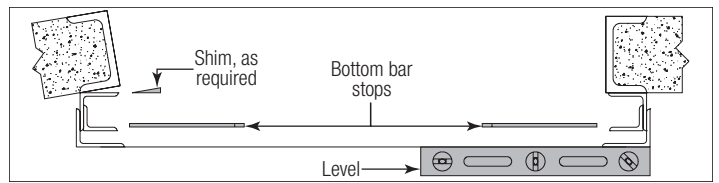

IMPORTANT: Wind load rated doors must use the applicable fastener/weld schedules specified in the wind load approval drawings. The fastener/weld schedule shown in this manual is only for non wind load rated doors.

APPLICABLE JAMBS

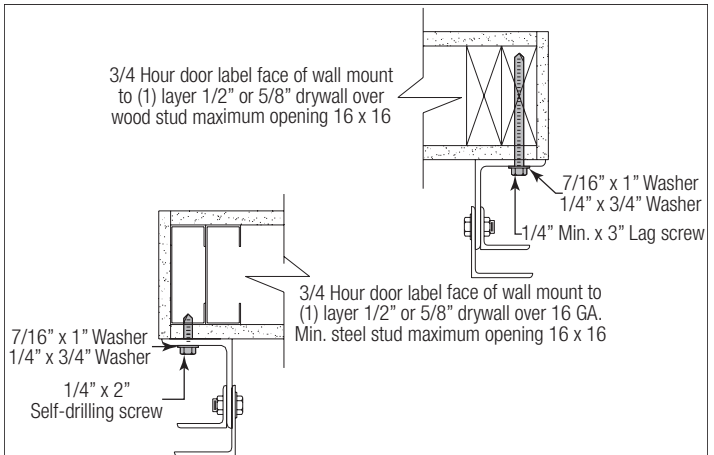
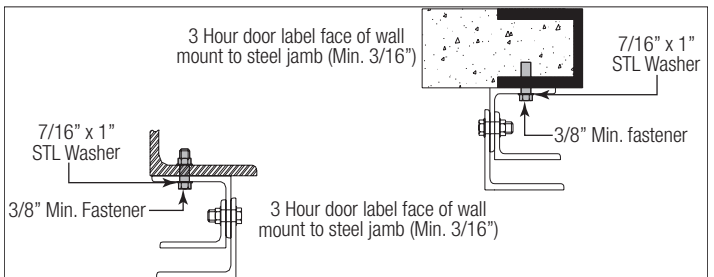
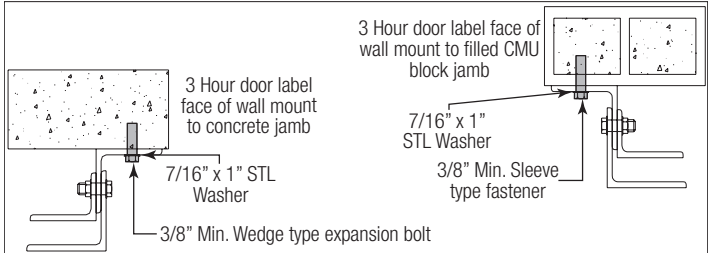
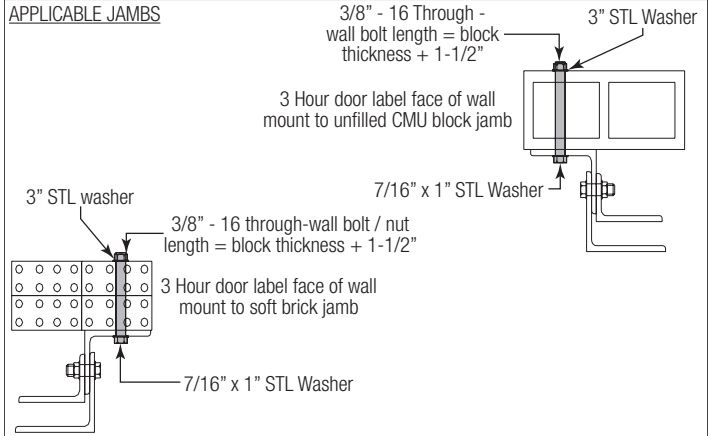

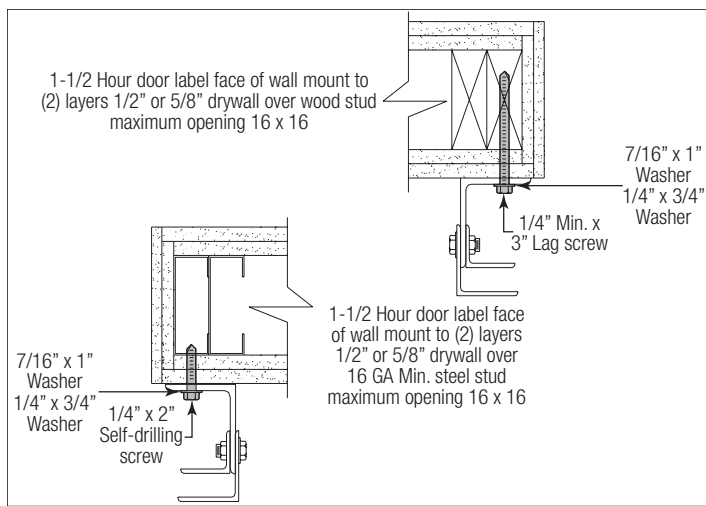

ALTERNATE WELDING OF GUIDES TO STEEL:

Welding the guides to steel jambs is an approved method of installation, providing it is done according to the following instructions.

NOTE: Welding of guides is approved for UL rated fire doors only. Welding of guides is NOT approved for FM rated fire doors.

IMPORTANT: The instructions below must be followed closely. Failure to do so may cause door to be inoperative or fail in event of a fire.

IMPORTANT: Wind load rated doors must use the applicable fastener/weld schedules specified in the wind load approval drawings. The fastener/weld schedule shown in this manual is only for non wind load rated doors.

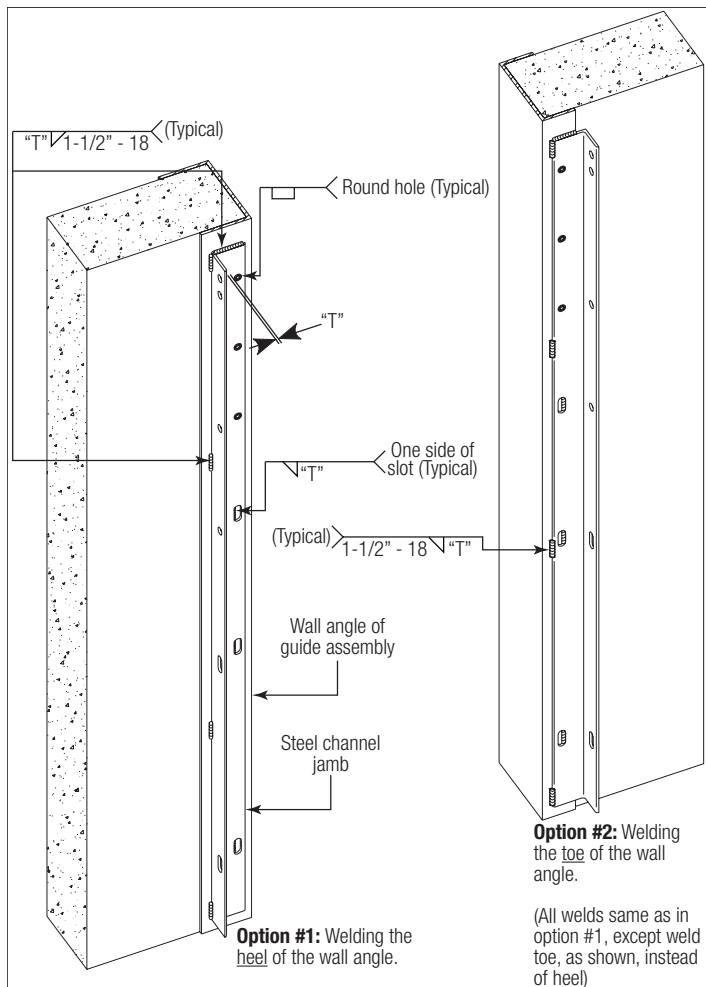

Use E6010 / E6011 electrodes or electrodes of equivalent strength. All welding must be done "vertical up" (i.e. starting the individual weld bead and welding upwards). Use fillet welds based on the information provided above.

IMPORTANT: Wind load rated doors must use the applicable fastener/weld schedules specified in the wind load approval drawings. The fastener/weld schedule shown in this manual is only for non wind load rated doors.

BETWEEN JAMB MOUNTED DOORS:

Unbolt the fourth angle (sometimes called the "packout" angle) from the three angle guide assembly (if supplied by factory).

NOTE: Extra angles are seldom the same size (right and left). After being unbolted, they must be re-attached to the correct side. Mark the angle "L" or "R" on the angle leg that mounts to the wall.

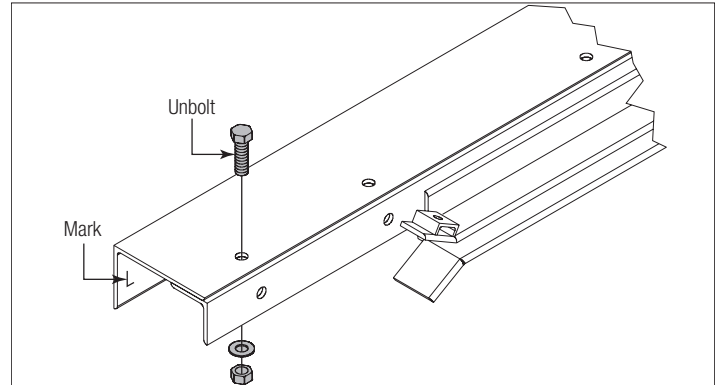

IMPORTANT: Hardware and bolt spacing requirements are determined by door size. Specific information on proper hardware is located on the hardware bill in hardware bag. Make sure each hole is filled with proper bolts supplied with door.

Guides that mount between the jambs install very similarly to face mounted doors. Follow the steps for face mounted doors except the "wall angle" is now the fourth or "packout" angle. Now reattach the guide assemblies to the packout angles. Next install the back bottom bar stops (see step #9).

NOTE: Openings are often not square. Hold the "C" dimension and shim packout angle from wall with metal shims as required. Any resulting gaps > 1/4" must be covered with sheet metal.

IMPORTANT: The galvanized washers must be installed to ensure proper guide expansion in event of fire.

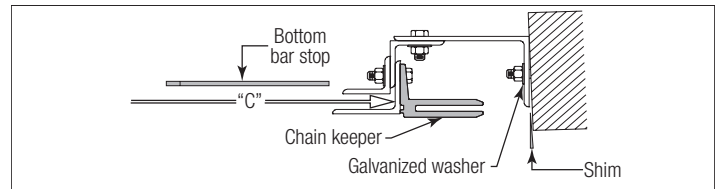

CHAIN KEEPER MOUNTING:

Once guides are completely installed, mount chain keeper on operator side of the door, 3' to 5' above finished floor, using guide assembly bolt. Chain keeper may vary from the one shown.

3 BRACKET TO SPRING BARREL INSTALLATION

! WARNING

SPRINGS ARE CLOSER TO ONE SIDE OF BARREL ASSEMBLY, CAUSING THAT SIDE TO BE HEAVIER. BARREL ASSEMBLY WILL FALL IF LIFTED FROM CENTER. TO AVOID POSSIBLE SEVERE OR FATAL INJURY, CAREFULLY DETERMINE BALANCE POINT, PRIOR TO LIFTING BARREL ASSEMBLY, TO PREVENT BARREL ASSEMBLY FROM FALLING.

⚠️ WARNING

BRACKET ASSEMBLIES CAN BE HEAVY. TO AVOID POSSIBLE INJURY, PERSONS WITH LIFTING LIMITATIONS SHOULD NOT PERFORM THIS NEXT STEP.

3A ADJUSTER SIDE BRACKET: Be sure to remove the adjusting wheel and any other items temporarily attached to the adjuster side bracket (this is the bracket with the adjusting wheel wired to it) to prevent them from falling. Lift the adjuster side bracket assembly into place, sliding the adjuster side shaft (this is the shaft with the flat on it) into the hole in the bracket assembly. Slide the adjusting wheel onto the flat of the barrel assembly shaft. Install the cotter pin in the shaft outside of the adjusting wheel, or tightly clamp with vice grips.

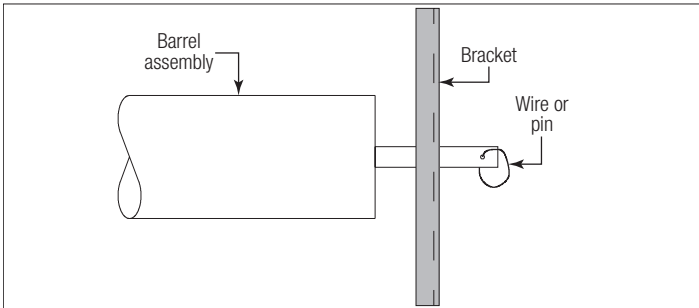

⚠️ WARNING

SECURE BRACKET TO BARREL ASSEMBLY USING SUPPLIED COTTER PIN, OR VISE GRIPS, TO PREVENT IT FROM SLIDING OFF DURING LIFTING. FAILURE TO SECURE BRACKET TO BARREL ASSEMBLY COULD RESULT IN SEVERE OR FATAL INJURY.

3B OPERATOR SIDE BRACKET: First remove the stub shaft temporarily attached to the operator side bracket (this will be the one with the drive assembly bolted to it) by loosening the set screws on the drive assembly hub. Discard the stub shaft.

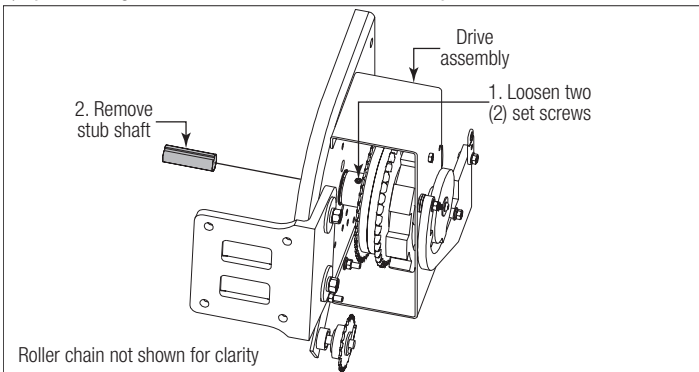

After removing the stub shaft check to make sure that a square key is still visibly in place in the key way of the drive assembly hub. This is not to be removed. Lift the operator side bracket assembly into place, sliding the door drive side shaft (this is the shaft with the keyway on it) into the hole in the bracket assembly and carefully align the drive shaft with the key in the drive assembly hub. (Helpful hint: loosen the 3 attaching bolts from the drive assembly to the end bracket.) Slide the bracket assembly on to the door drive shaft until it stops. **BACK THE BRACKET ASSEMBLY OUT ABOUT 1/4". RE-TIGHTEN THE TWO SET SCREWS LOOSENED EARLIER.**

Center the barrel assembly between the two bracket assemblies.

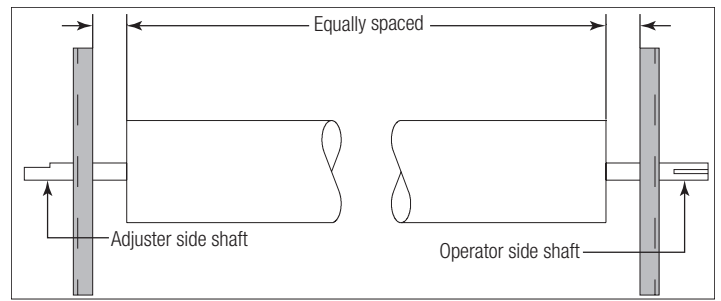

HINT: Drive assembly can be removed from bracket if necessary. Loosening the fastening bolts from the drive assembly to the end bracket may ease the installation of the assembly to the drive shaft. Re-tighten after assembly.

4 BARREL ASSEMBLY INSTALLATION

⚠️ WARNING

SECURE BRACKETS TO BARREL ASSEMBLY TO PREVENT IT FROM SLIDING OFF DURING LIFTING, POSSIBLY CAUSING SEVERE OR FATAL INJURY.

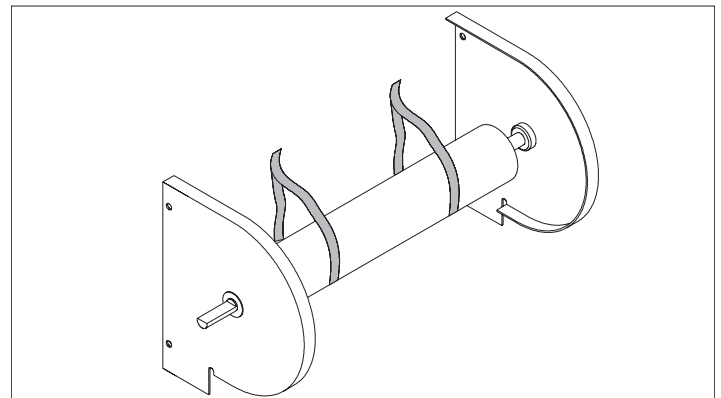

Using a chain hoist, fork lift, sling or some means of lifting, determine the balance point of the barrel assembly with the brackets mounted on it.

⚠️ WARNING

SPRINGS ARE CLOSER TO ONE SIDE OF BARREL ASSEMBLY, CAUSING THAT SIDE TO BE HEAVIER. BARREL ASSEMBLY WILL FALL IF LIFTED FROM CENTER. TO AVOID POSSIBLE SEVERE OR FATAL INJURY, CAREFULLY DETERMINE BALANCE POINT, PRIOR TO LIFTING BARREL ASSEMBLY, TO PREVENT BARREL ASSEMBLY FROM FALLING.

Lift the assembly into place and secure the brackets to the guide wall angles as described below.

NOTE: Brackets install on side of wall angle away from clear opening.

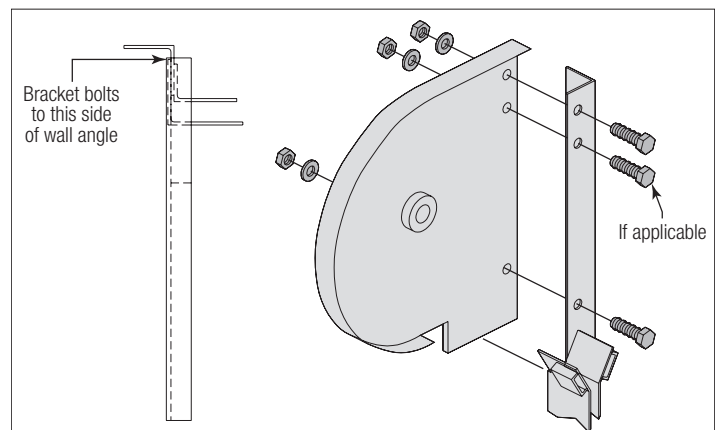

IMPORTANT: Install bracket bolts from inside so that nuts are on outside of wall angle to keep bolts from interfering with curtain.

Some brackets are symmetrical and therefore have more holes in them than the wall angle.

Doors using the 14" bracket assembly that are less than 13'6" wide and 12' high only require 2 bracket mounting bolts. Refer to your hardware list for fastener quantity.

WARNING

SUPPORT BARREL ASSEMBLY UNTIL ALL BRACKET BOLTS ARE INSTALLED AND SECURED, OTHERWISE ASSEMBLY COULD FALL AND POSSIBLY CAUSE SEVERE OR FATAL INJURY.

5 OPERATOR MECHANISM INSTALLATION

5A BARREL / BRACKET ASSEMBLY – MANUAL LIFT - UP AND AWNING CRANK OPERATED:

WARNING

SPRINGS ARE CLOSER TO ONE SIDE OF BARREL ASSEMBLY, CAUSING THAT SIDE TO BE HEAVIER. BARREL ASSEMBLY WILL FALL IF LIFTED FROM CENTER. TO AVOID POSSIBLE SEVERE OR FATAL INJURY, CAREFULLY DETERMINE BALANCE POINT, PRIOR TO LIFTING BARREL ASSEMBLY, TO PREVENT BARREL ASSEMBLY FROM FALLING.

WARNING

BRACKET ASSEMBLIES CAN BE HEAVY. TO AVOID POSSIBLE INJURY, PERSONS WITH LIFTING LIMITATIONS SHOULD NOT PERFORM THIS NEXT STEP.

Lay the barrel assembly in front of the opening.

NOTE: The sticker located on the barrel. This sticker will indicate the operated end, the direction the curtain uncoils to close the shutter and the spring turns required to balance the shutter.

Slide the brackets onto the barrel shaft extensions and place the brackets on wood blocks. Install a cotter pin onto the barrel shaft extension (with the flat) (do not install the adjusting wheel at this time). Install the sprocket, 1/4" shaft key, and snap ring onto the shaft. Locate the sprocket so that it contacts the snap ring, and tighten the set screws. Next, move the inner set collar and thrust bearing (between the barrel and inside surface of the bracket) against the inside bearing race on the bracket, and tighten the set screws (prevents lateral barrel / shaft movement).

IMPORTANT: Determine proper orientation of barrel as indicated by sticker on barrel (examples below).

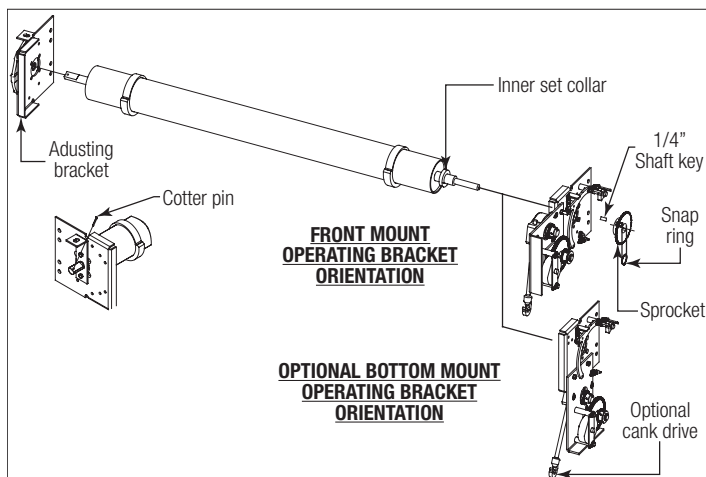

5B CHAIN HOIST OPERATOR: Loosen the two (2) bolts fastening the chain hoist support to the bracket. Slide the chain hoist towards the front of the bracket to increase the tension on the roller chain.

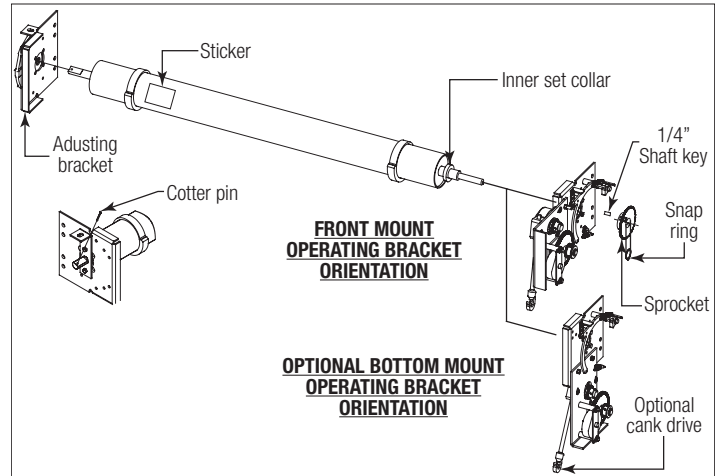

Adjust chain until slack is between 1/4" and 1/2", as shown in the illustration below. If the chain slack exceeds 1/2", re-cut roller chain.

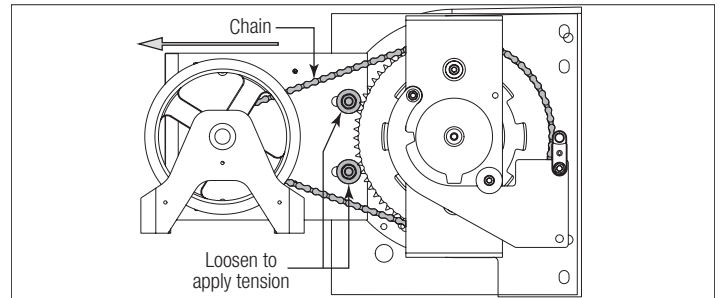

WARNING

PROPER INSTALLATION WILL RESULT IN DOOR BEING UNDER BALANCED. ROLLER CHAIN SLACK MUST BE LESS THAN 1/2" TO PREVENT CHAIN FROM COMING OFF, ALLOWING DOOR TO FREE FALL, POSSIBLY CAUSING SEVERE OR FATAL INJURY.

IMPORTANT: Excessively tight roller chain can prevent door from dropping properly during drop test or in case of actual fire.

Be sure to re-tighten the bolts that were loosened earlier.

5C MOTOR OPERATOR: Lift and fasten motor operator to support bracket using supplied hardware. Loosen the limit roller chain tension idler sprocket assembly. **DO NOT REMOVE THE ASSEMBLY.**

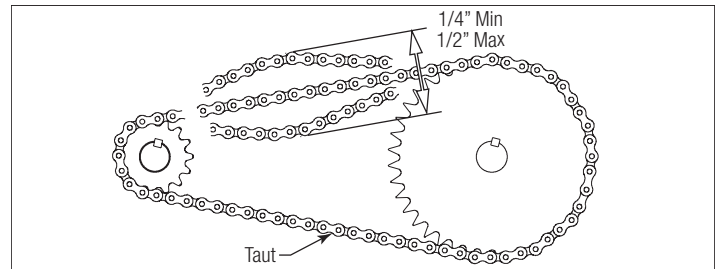

Loop limit roller chain around limit switch sprocket on motor operator and tension idler sprocket on bracket. Do not pull limit roller chain taut at this time. Loop the drive chain around drive sprocket on motor operator.

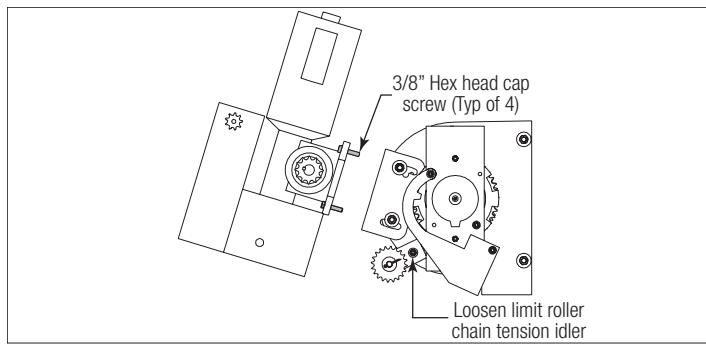

Loosen top bolt fastening the support to the bracket. Rotate the motor operator and support to tension the drive chain. Tighten the top bolt to fasten support in place. Adjust tension idler assembly to tension the limit roller chain and tighten in place.

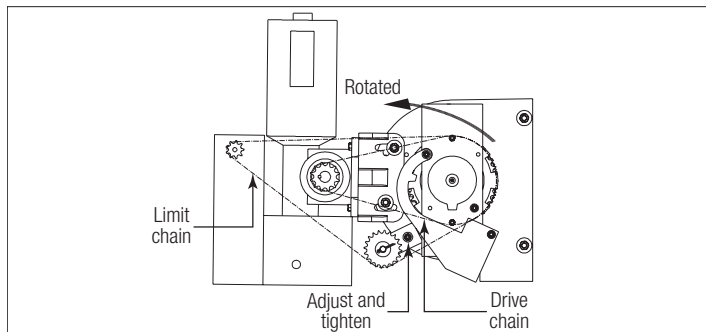
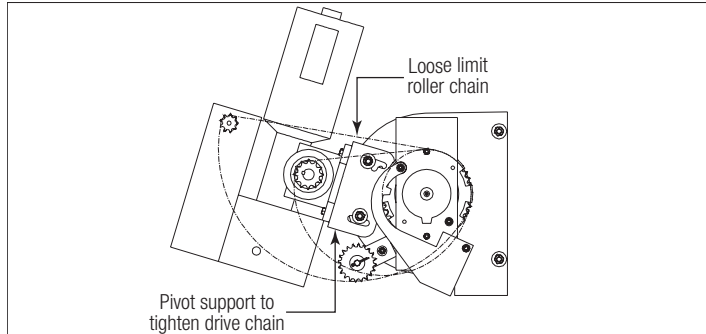

WARNING

PROPER INSTALLATION WILL RESULT IN DOOR BEING UNDER BALANCED. ROLLER CHAIN SLACK MUST BE LESS THAN 1/2" TO PREVENT CHAIN FROM COMING OFF, ALLOWING DOOR TO FREE FALL, POSSIBLY CAUSING SEVERE OR FATAL INJURY.

IMPORTANT: Excessively tight roller chain can prevent door from dropping properly during drop test or in case of actual fire.

6 CURTAIN ASSEMBLY INSTALLATION

Position the curtain assembly parallel with the door opening so that the top attachment slat is in front of the rest of the curtain (the hinged part away from the opening).

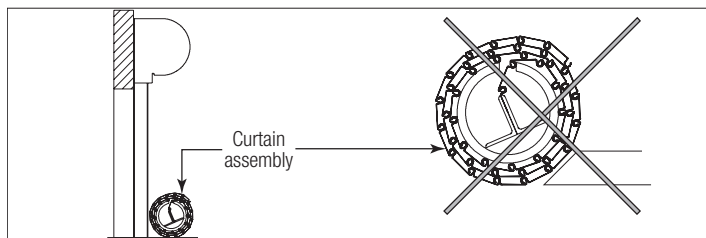

CAUTION

DO NOT ATTEMPT TO SLIDE FORKS OF LIFT TRUCK DIRECTLY BETWEEN FLOOR AND CURTAIN. PERMANENT DOOR DAMAGE MAY RESULT.

WARNING

CURTAIN MUST BE SECURELY ATTACHED TO LIFTING MECHANISM. OTHERWISE, CURTAIN COULD FALL CAUSING POSSIBLE SEVERE OR FATAL INJURY.

Lift curtain assembly (centered between guide assemblies) to approximately one foot below the barrel assembly, using ropes or straps of adequate strength to safely support curtain assembly weight. Remove steel banding from around curtain assembly.

WARNING

BANDING IS UNDER TENSION. TO AVOID POSSIBLE INJURY, WEAR EYE PROTECTION AND DO NOT STAND IN FRONT OF BANDING WHEN CUTTING IT.

Temporarily engage the drop arm by tying the arm in the engaged position. Using a chain hoist, rotate barrel assembly until top slat attachment point is accessible. Feed top slat around back side of barrel assembly until top slat is out in front of barrel assembly. Install the top slat attachment bolts and nuts, verifying that the curtain is centered between the brackets.

Continue rolling the curtain up around the barrel assembly until the entire curtain is coiled onto the barrel assembly. Clamp or block the guide assembly approximately 6" down from the top of the guides. Loosen the safety ropes enough to let the curtain feed into the guide grooves.

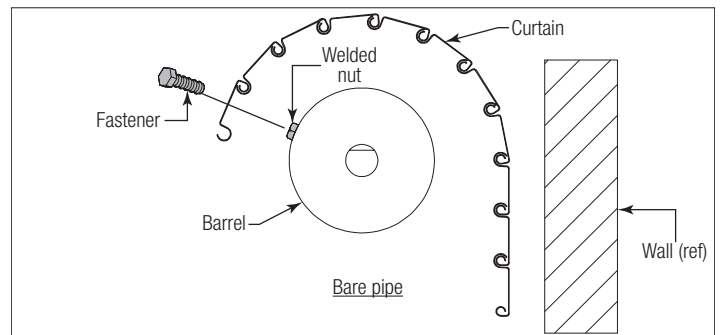
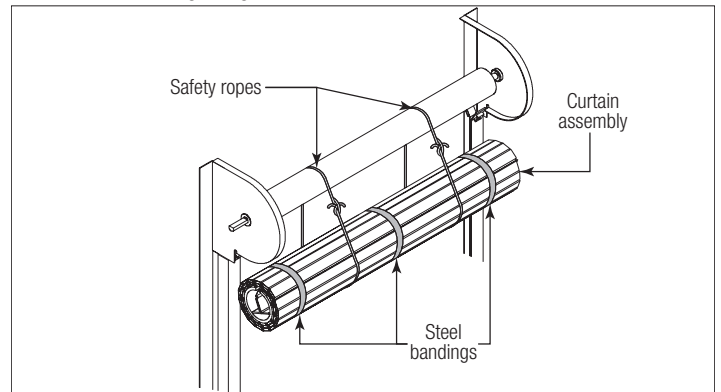

WARNING

NO TENSION HAS YET BEEN APPLIED TO DOOR. IF CURTAIN IS ALLOWED TO ROTATE AND FREE FALL, SEVERE OR FATAL INJURY COULD RESULT. KEEP THE CURTAIN SECURE AND PREVENT FROM ROTATING.

7

RELEASE HANDLE MOUNTING

Carefully read the instructions packaged with the release handle assembly. The release handle assembly is designed to be mounted to the wall on the operator side of the door. It is desired to position the release handle assembly in a location that is easily accessible, yet sufficiently out of the way to prevent interference with chain hoist operation.

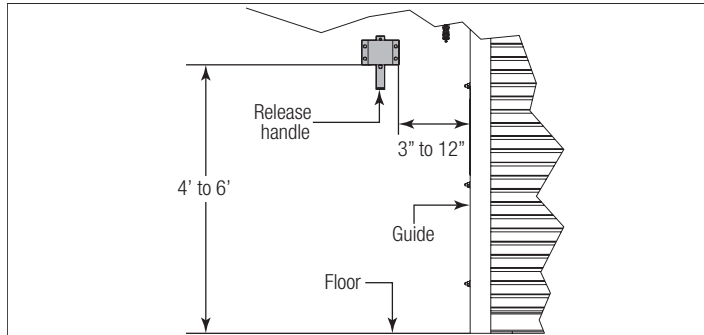

While individual installation locations may vary depending on site conditions, there commended location is shown in the illustration. Determine where the release handle assembly will be installed and attach it to the wall using the fasteners provided. Again, be sure to choose a location that is convenient to operate and will avoid interference with the chain hoist operation and any obstacles that may be in the path of the cable routing.

8

ADJUST WHEEL INSTALLATION AND TENSION APP.

8A OUTSIDE AW:



WARNING

VERIFY THAT AT THIS POINT, THE ADJUSTING WHEEL IS FREE AND THERE IS NO SPRING TENSION.



WARNING

ADJUSTING WHEEL HOLDS SPRING TENSION. FAILURE TO PIN SHAFT COULD ALLOW ADJUSTING WHEEL TO FALL OR DOOR TO FREEFALL CAUSING SEVERE INJURY OR DEATH. VERIFY THAT COTTER PIN IS INSTALLED TO RETAIN THE ADJUSTING WHEEL.

Locate the door in the full up position such that the bottom bar is against the bottom bar stops and place a clamp on each guide no more than 6" below the bottom bar. Make certain that the clamping force will be sufficient to stop the door when it rests on the clamps. Carefully lower the curtain so that the bottom bar rest on the clamps. By hand, rotate the adjusting wheel (AW) slightly both directions to determine the neutral point of the spring counterbalance. Mark the hole in the AW that is nearest to the retaining lug on the bracket.

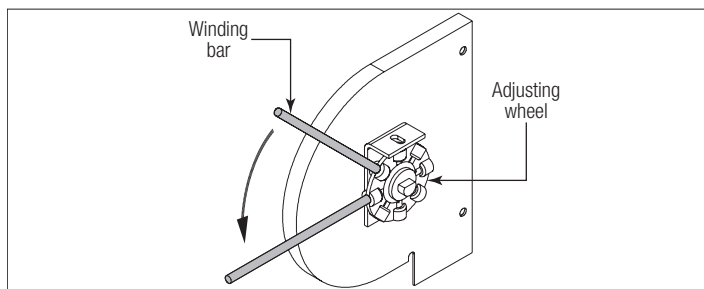

NOTE: Tension is applied in the direction the coil would turn as the door moves upward.



WARNING

WINDING BAR MUST FIT SNUGLY INTO HOLES IN ADJUSTING WHEEL. DO NOT USE LOOSE FITTING BAR OR SCREWDRIVER WHICH COULD DISLodge RESULTING IN POSSIBLE SERIOUS INJURY OR DEATH.

Using approved winding bar (per tool list in front of manual), insert the two rods securely into the holes in the AW as shown. Add tension so that the door slowly rises off the clamps and stops at the bottom bar stops.

HINT: If conditions permit, use wall as brace for winding rod for a safe procedure of installing the AW pin as shown.

NOTE: FireStar® doors have approximately ZERO spring tension when completely open, after being fully installed and adjusted. In some cases, negative backwinds (winding the spring backwards) a small amount may be necessary for the door to operate and drop test correctly.

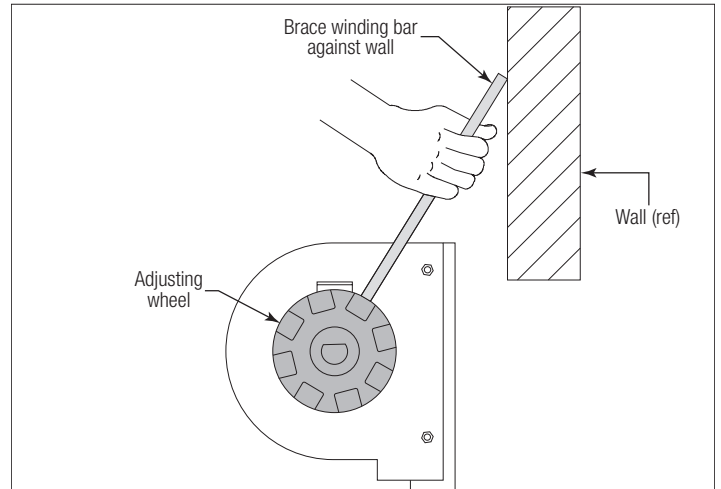

WARNING

EXERCISE CAUTION WHEN APPLYING OR ADJUSTING SPRING TENSION. CONTACT WITH RAPIDLY ROTATING ADJUSTING WHEEL OR EXPELLED WINDING ROD CAN CAUSE SERIOUS INJURY OR DEATH.

While holding the winding bar firmly in one hand, insert the AW pin with the other hand through the lug in the bracket and into the hole in the AW to lock the AW at the desired number of revs. Remove winding rods.

IMPORTANT: Door will not function properly if tension is not further adjusted per step #13. Failure to perform step #13 will void the fire rating of this door.

8B MANUAL LIFT-UP AND CRANK OPERATION: Installing the drop mechanism components.

IMPORTANT: Winding the counterbalance spring, must be completed prior to performing these next steps. Door must be in fully CLOSED position for step 10A.

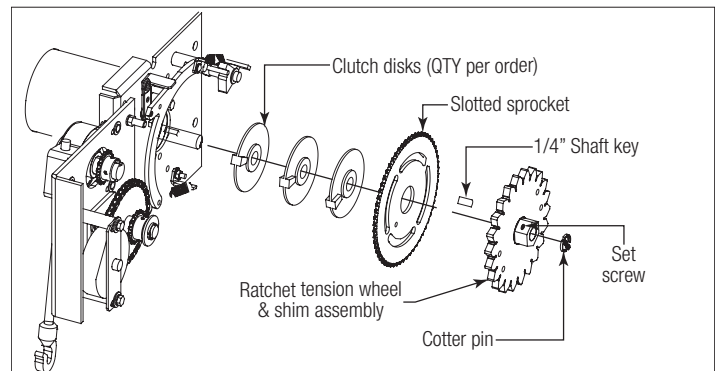

Install the clutch disks onto the 3/4" diameter shaft. Install the slotted sprocket, spacer, 1/4" shaft key and ratchet tension wheel as shown. Fasten the cotter pin in the end of the 3/4" shaft, to secure the components from moving laterally. Tighten all set screws on the door sprocket and inner set collar. Verify that the clutch disks rotate freely. Orient the clutch disks and slotted sprocket as shown below:

RIGHT HAND OPERATED

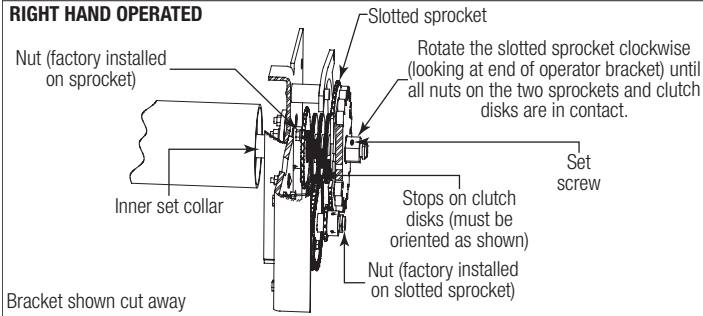

LEFT HAND OPERATED

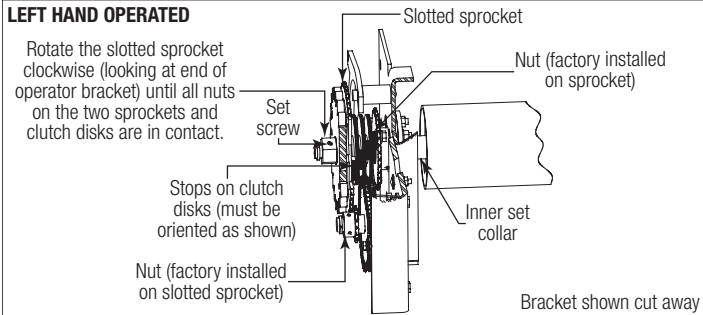

Install the chain from the slotted sprocket to the idler sprocket, and if crank operated, install the chain from the drive sprocket on the awning crank to the door sprocket. Adjust each chain so that there is 1/4" to 1/2" of slack as shown for proper operation and automatic closure functionality. The idler sprocket and chain tension is adjustable by loosening the mounting bolts on the opposite side. (If the idler sprocket location is adjusted, the centrifugal clutch chain tension will also require adjustment). Re-tighten all bolts & nuts.

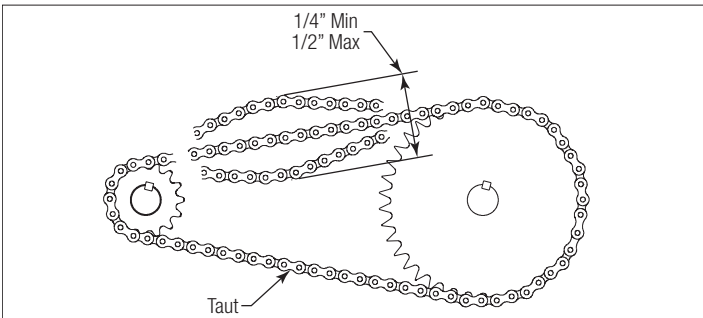
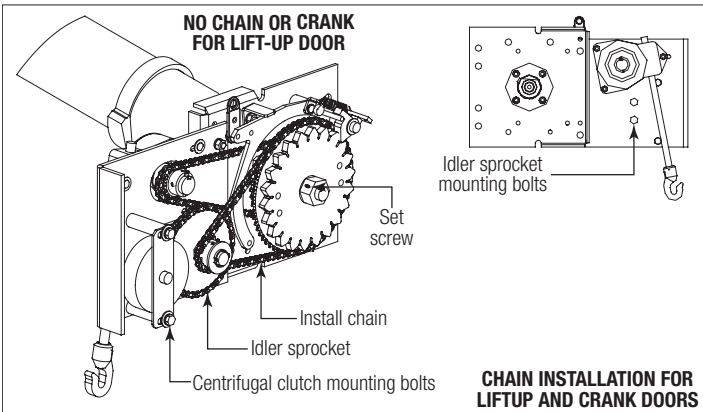

WARNING

EXERCISE CAUTION WHEN APPLYING, ADJUSTING, AND SECURING SPRING TENSION. CONTACT WITH RAPIDLY ROTATING TENSION WHEEL OR EXPELLED WRENCH CAN CAUSE SERIOUS INJURY OR DEATH.

WARNING

ACTIVATING THE TEST HANDLE WILL RELEASE SPRING FORCES, CAUSING THESE PARTS TO SPIN RAPIDLY AND CAN POTENTIALLY CAUSE SEVERE INJURY TO ANY PERSON IN CONTACT. ENSURE RELEASE LEVER AND TEST HANDLE IS IN THE LOCKED POSITION AND SECURED BEFORE AND DURING THE TIME YOU PERFORM THIS STEP.

Now, the push-down spring (connected to the 3/4" diameter shaft) must be wound. The shutter must be in the closed position. Install the test handle, fusible links, turnbuckles and cable and attach to the release lever (per Step 11). Rotate the release lever upwards and secure it so that the ratchet tooth engages the tension wheel teeth. Using a pipe wrench, rotate the tension wheel downwards (towards the floor) and apply 1-1/2 to 1-3/4 full turns of tension on the push-down spring. Install the (2) 5/16" - 18 x 1-1/4" carriage head bolts through the slotted sprocket, spacer, and ratchet tension wheel and tighten them securely with the washers, lock washers, and 5/16" nut.

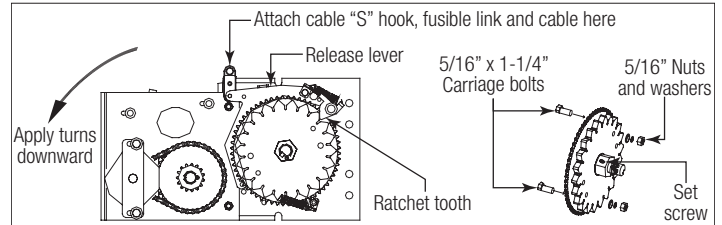

8C COMPOUND AW (SPROCKET REDUCTION): See Appendix D, "Compound Tension Adjuster Assembly", for instructions to wind a compound AW. With the curtain up, wind the initial revs with 3/4" winding bars approximately 36" long by counting the revs of the large sprocket.

9 BOTTOM BAR STOP INSTALLATION

Place two 1/4" - 20 stud plates through the holes in the flare at the top of the guide as shown. Line up the holes in the bottom bar stop with the studs and assemble using four 1/4" - 20 flange nuts. Adjust bottom bar stops to obtain maximum contact with bottom bar ensuring bottom bar cannot come out of guides. Tighten flange nuts until secure. **Do not over-tighten.** Repeat for both flares of both guides.

Prior to Step #10, remove the safety ropes and clamps or blocks at the top of the guides.

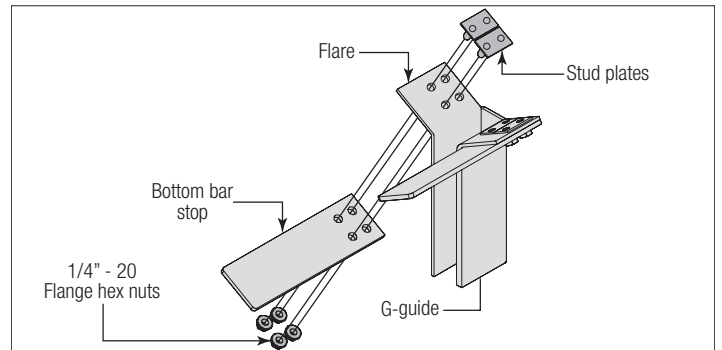

10 FUSIBLE LINKS AND CABLE ROUTING

IMPORTANT: Secure the door from moving until the fusible link cable routing is complete.

NOTE: Fuse cables must be routed and fusible links installed per NFPA 80 requirements. Refer to NFPA 80 manual as required and install cables and fusible links per applicable building conditions.

The fuse cable should route from the end of the Firestar® drop arm.

Fusible links are designed to melt in the event of a fire and are shipped in the hardware bag. The links must be located in such a way that they will be exposed to any fire that may be inside the building.

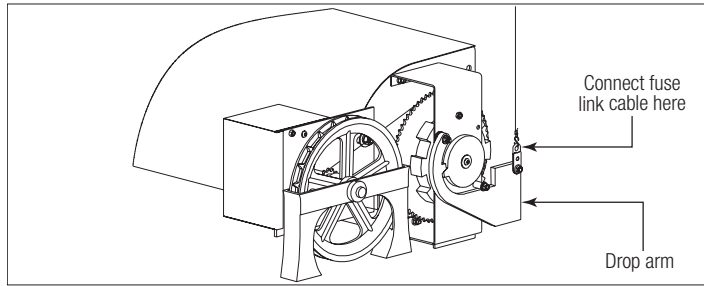

IMPORTANT: The drop arm on the Firestar® drive assembly must disengage regardless of which connection in the cable separates.

IMPORTANT: Per NFPA 80, fusible links must be located 4" to 12" below ceiling on both sides of door opening and near door opening on the side door is mounted. Standard fuse links are rated 165°F, make sure other fire systems are compatible with this temperature.

Fuse cable routing is to accomplish two tasks. First, the cable routing must position fuse links in the locations specified in NFPA 80. Second, fuse cable must go to the release handle with length such that pulling the release handle down engages the drop arm. The release handle can be kept in down position by using the pin supplied in the hardware bag.

All fusible links must be at least 6" away from any fixed point (ex: pulleys, thru-wall pipe, etc.) or sufficient enough that the drop arm of the drive unit can pivot if any fuse link were to melt. Fuse links are required on coil side of door opening both near the opening and 4" to 12" away from the ceiling. A fuse link is also required on opposite coil side 4" to 12" away from the ceiling. It is recommended that fuse links be located near the opening on both the operator and non-operator sides for doors wider than 15'. Plan cable routing to avoid interference with hood and/or fascia installation described in step #11. If a drive housing and/or adjusting wheel housing has been provided, see Appendix A and plan cable routing to avoid interference with these as well.

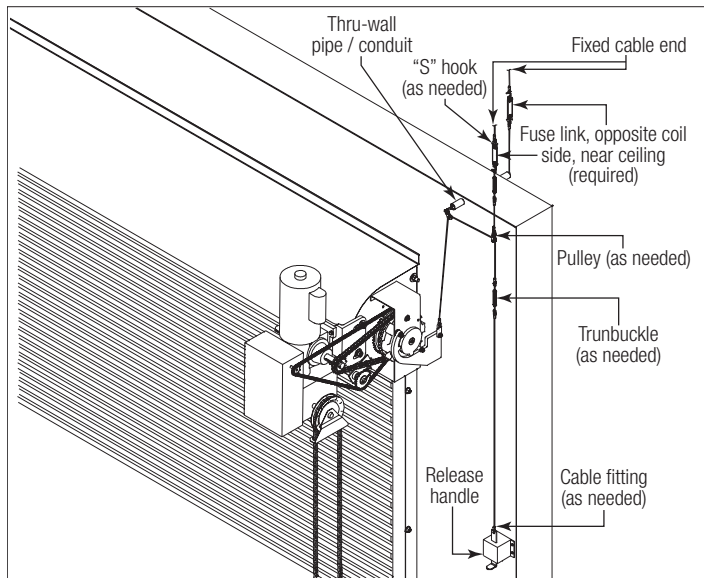

Turnbuckles should be used so that cable tension can be fine tuned for operation of the release handle. All turnbuckles should be located high enough that they are out of reach to avoid tampering.

Fuse cable must be vertical when it attaches to the release handle to avoid possible complications with engaging the drive drop arm. Cable routing requires a great deal of planning and is influenced heavily by field conditions. The illustration represents one possible fuse cable routing approach that meets NFPA 80 requirements. A drawing with additional fuse cable routing illustrations can be found in the hardware bag.

IMPORTANT: NFPA 80 regulations require a fuse link housing to keep the fuse link exposed to the heat of a potential fire, if a drop or false ceiling is installed above the door opening.

In addition to fusible links, some construction codes require that the door(s) be integrated into the building's fire alarm system. This can be accomplished with electro-mechanical release devices such as WayneGuard™. For such devices, see Wayne Dalton dealer.

11 HOOD INSTALLATION

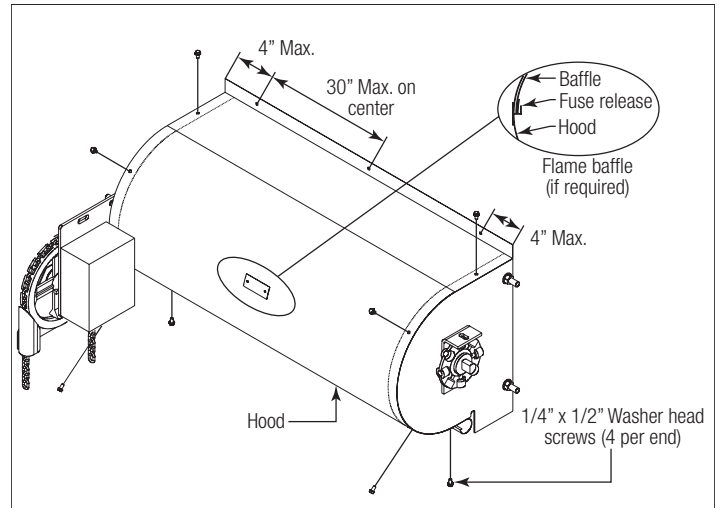

Hoods over 14' long require the use of intermediate support(s). For hoods equipped with a flame baffle, the supports go outside the hood. These are bolted to the hood using screws from the inside of the hood. Raise the front hood and set over the flanges on the bracket assemblies. Fasten hood to brackets using the 1/4" diameter self-tapping washer head screws provided. Fasten hood securely to the wall using the fasteners listed on the hardware bill.

IMPORTANT: NFPA 80 does not approve the use of lead anchors on rolling fire door installations.

FASCIA / BACK HOOD INSTALLATION:

Between jamb doors and some face mounted doors often require the use of a fascia on the back of the coil to cover the curtain assembly. Install the fascia onto the outermost angle on between jambs mounted doors and between the wall angle and the wall on face mounted doors. It may be necessary to cut a notch where the top one or two guide bolts are installed.

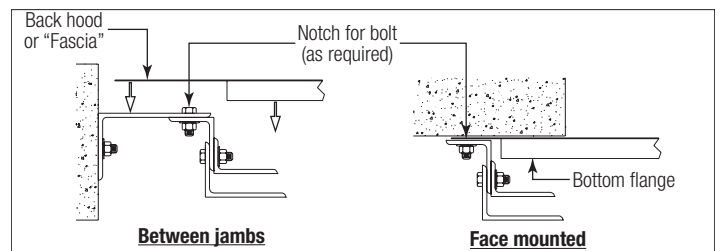

12 APPLYING CHAIN HOIST BRAKE FORCE

NOTE: This is a preliminary brake force and should be adjusted per step #13.

The brake lock nut is factory set for a preliminary compression. If the door drifts at any point through the door's travel, tighten the brake lock nut (to compress the brake springs). In some cases, large doors require more compression. Open and close the door making sure the door does not drift at any point through the door's travel. Replace the brake housing after final adjustments are made per step #13.

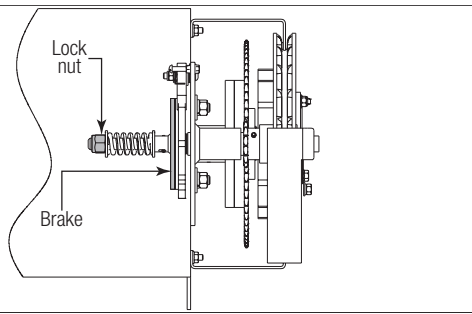

13 LEVEL DOOR (IF NEEDED)

If during previous step the door rolled up level and straight, skip this step.

- A. Check that guides are plum, square, level, and are properly mounted onto floor and wall.
- B. Check that the pipe is level.
- C. Check that the attachment of the curtain is straight on the pipe.

If all of the above is correct and the door still rolls up out of level, a shim may need to be added, as shown below.

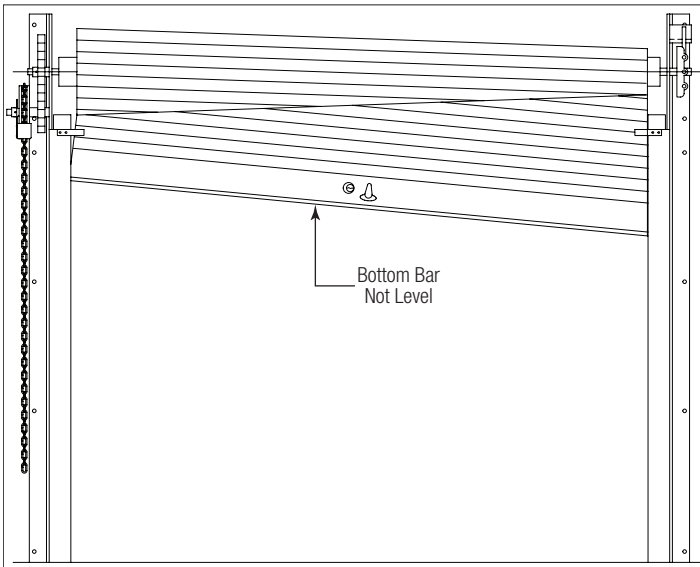

SHIM MATERIALS:

- A piece of rubber is the desired material for a shim.
- A piece of cardboard could be used but may deteriorate over time.
- Use a 1/8" x 6" x 6" thick piece of material and increase thickness or pieces depending on the result acquired, as shown below.

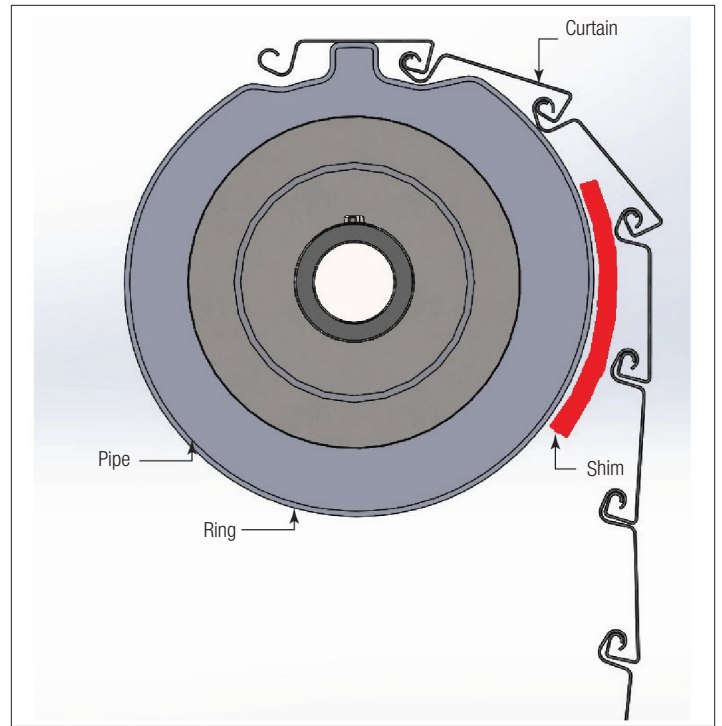

APPLICATION OF SHIM:

To determine the side in which the shim will be applied, the door will need to be in the open position.

When facing the door, the bottom bar will be unlevel. The lower side of the bottom bar will be the side in which the shim needs to be placed.

The hood may need to be loosened or removed for the application of the shim.

To apply the shim, two laborers might be required.

INSTALLING THE SHIM:

- D. Close the door fully.
- E. When door is at bottom make sure door is in hand chain mode.
- F. Turn off the power to the motor (if applicable) to ensure safe application of the shim.
- G. Backwind the door using the chain. Lock chain in place using chain keeper.



WHEN THE DOOR IS WOUND BACKWARDS THERE IS A FORCE IN WHICH THE DOOR WILL WANT TO WIND FORWARD. SECURE THE DOOR IN THIS POSITION BY LOCKING HAND CHAIN ONTO CHAIN KEEPER TO PREVENT INJURY.

H. As the curtain is wound backwards apply the shim to the lower side between the pipe and slats or on the ring of the low side.

I. Restore power to the motor (if applicable).

J. Check the level of the bottom bar while door is in the open position. If it is not level, add a second shim and check again.

NOTE: If the door has wind locks there may be some stacking interference in the wind locks as the door is wrapping during operation. This is a normal characteristic. For wind lock applications the doors bottom bar should be level at the open position.

14

TENSION REMOVAL AND TEST DROP PROCEDURE

IMPORTANT: Failure to perform this step properly and in its entirety will void the fire rating of this door

IMPORTANT: Secure the hand chain in the chain keeper before all drop tests in case the brake nut is not sufficiently tightened. Failure to perform this step properly and in its entirety can result in rapid descent of door when operated causing possible serious injury or death.

Locate the door in the full up position such that the bottom bar is resting on the bottom bar stops and place a clamp on each guide no more than 6" below the bottom bar. Make certain that the clamping force will be sufficient to stop the door when it begins to fall. Position the release handle to the "test", or up, position releasing drop arm and disengaging chain hoist. Move the chain of the chain hoist to make sure it is disengaged. Using the tensioning method described in step #8, gradually remove spring tension until door falls to the clamps. Lock tension to the bracket lug using the nearest hole in the adjusting wheel.

WARNING

ADJUSTING WHEEL MUST BE PINNED TO BRACKET LUG REGARDLESS OF TENSION AMOUNT. FAILURE TO PIN ADJUSTING WHEEL TO BRACKET LUG WILL RESULT IN RAPID DESCENT OF DOOR WHEN OPERATED CAUSING POSSIBLE SERIOUS INJURY OR DEATH.

To re-engage the release handle, gently apply pressure to the handle in the downward direction until the hole in the handle is visible on the bottom side of the handle box. It may be necessary to rotate the hand chain slightly to allow the handle to descend far enough. Insert pad lock or pin through the hole to secure the handle in the operate, or down position.

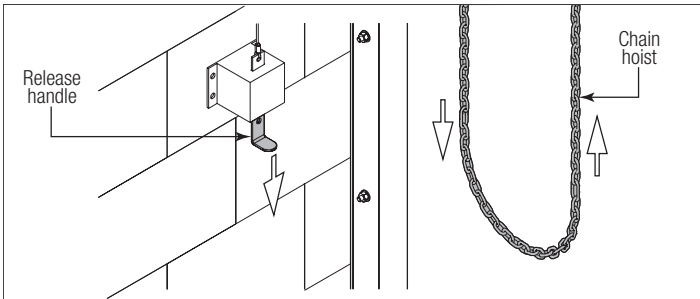

Rotate hand chain to ensure that the drive unit is engaged and that the door is not resting on the clamps. Remove the clamps installed on the guides. Hoist door down and once back up to make certain that door is operating properly.

IMPORTANT: PRIOR TO DROPPING, ENSURE DOOR OPERATES FREELY AND PROPERLY IN NORMAL OPERATION.

WARNING

DOOR DESCENDS RAPIDLY DURING TEST PROCEDURE. ROPE OFF OPENING AND KEEP PERSONS FROM ENTERING AREA DURING TEST DROP. KEEP ALL PERSONS CLEAR OF OPENING OR SERIOUS INJURY OR DEATH COULD OCCUR. SECURE THE HAND CHAIN IN THE CHAIN KEEPER BEFORE ALL DROP TESTS.

CAUTION

KEEP OPENING FREE OF OBJECTS AND DEBRIS. DOOR COULD STRIKE SUCH OBJECTS CAUSING INJURY OR PROPERTY DAMAGE.

With door resting on bottom bar stops, stand clear of the door opening and move the release handle to the test, or up position. If tension is adjusted properly, the door should fall from the bottom bar stops and descend to the closed position. If door does not fall, repeat tension removal procedure. If door falls, re-engage release handle as instructed above and hoist the door to the open position. If door is difficult to hoist, add small amounts of tension and test to make certain that door falls every time.

Once all tension adjustments have been made, hoist door to open position. Release the handle and record the amount of time the door takes to close and verify it falls between 6 and 24 inches per second. If door falls slower than 6 inches per second, remove spring tension per step 8, and recheck descent speed. If door falls faster than 24 inches per second, add spring tension per step 8, and recheck descent speed. Raise door to fully open position several times and repeat drop procedure to verify it is working correctly and consistently. Reengage the release handle and complete the release form provided in the hardware bag and return a copy to the factory.

Once the door has been properly drop tested, the hoist brake should be adjusted so it just barely stops the door at the maximum out of balance to avoid adding excessive effort to close the door. If the door drifts excessively from this position, tighten the brake lock nut a small amount. Retest door operation. If door continues to drift excessively from any location, tighten the nut more. If door does not drift excessively at any location, make sure the nut has not been tightened too much as this will make the door difficult to operate.

15

MISCELLANEOUS FINAL CHECKLIST

Apply all warning labels in the appropriate locations before leaving the installation site.

Check the area for any extra parts, and be sure these were not omitted in the installation process.

NOTE: Re-check all bolted connections to verify all are securely tightened.

Clean up the area and make sure it is secure, with the handle engaged with the pin provided.

If the building owner or facility manager is unfamiliar with the product, demonstrate the operation of the door and any optional equipment before leaving the job site. Be sure to demonstrate how to safely drop test the door and point out the importance of Pad-Locking the release handle to avoid possible tampering.

Have the customer or his representative sign off on the installation using the "Rolling Fire Door Test Drop Release Form" provided in the hardware bag and also fill out the "Test Drop Release Form" in the back of this manual. Return a copy of form in the hardware bag to Wayne-Dalton and keep a copy in your maintenance files. Exchange all documentation and keys to locks at this time. Be sure the customer receives a copy of this manual and of the installation drawing.

Be sure to report (in writing) to the factory any complaints or recommendations the customer may register at the completion of the installation that may have a bearing on future designs.

IMPORTANT: WARNING LABEL MUST BE APPLIED TO OPERATED SIDE OF THE ROLLING DOOR, ON THE GUIDE, 5 FEET ABOVE THE FLOOR.

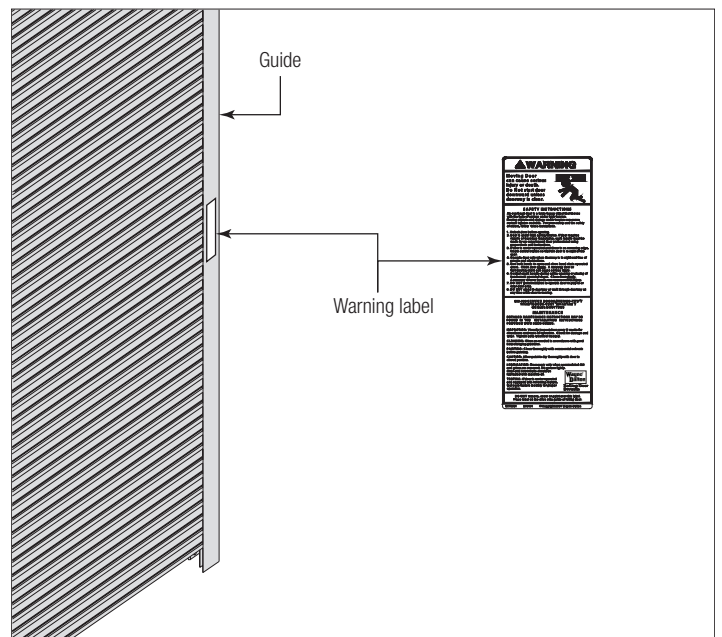

18

APPENDIX C: TROUBLESHOOTING

The chart below is a list of possible problems with the operation of the fire door. The possible causes listed are the most common, and are not meant to include all possibilities. With the variety of the product and the field conditions, other factors may be involved. If assistance beyond this troubleshooting chart is needed, please contact your Wayne Dalton dealer. Factory support is available to them, should it be necessary, in order to resolve your problem.

Trouble	Possible Cause	Remedy
Door stops very slow during test	*Roller chain too tight *Too much spring tension *Binding of door	*Verify roller chain is slack within limits defined in step #5. *Remove spring tension as instructed in step #13. *Check for binding / interference and correct.
Door stops too fast during test	*Too little spring tension	*Add spring tension per step #13 and #8.
Door does not drop during test	*Too little spring tension	*Remove spring tension as instructed in step #13.
Curtain runs to one side	*Broken endlocks *Barrel not level	*Check and replace. *Check and level barrel.
Door sticks when closing	*Bent guide angle(s)	*Inspect for bent or kinked guides. *Straighten guides and check width of groove.
Door coil makes cracking sound	*Bent slats	*Inspect, remove and straighten or replace.
Door squeaks when operating	*Tight guides *Dirty guides	*Check alignment and distance between guides. *Inspect and clean inside of guide. Do not lubricate with grease. Use WD-40 or silicone spray.
Door is difficult to raise, will not stay open	*Insufficient counterbalance *Broken spring	*Increase spring tension and repeat drop test procedure. *Remove barrel and replace.
Hand chain moves, door does not operate	*Release arm is disengaged	*Verify release handle is locked down. *Increase release cable tension.
Motor runs, Shutter does not operate	*Curtain jammed	*Inspect and remove obstruction.
Door won't drop	*Insufficient push-down spring tension, excessive counterbalance spring tension, release lever not activating, curtain jammed *Excessively tight chain	*Review Steps 5 thru 9. Adjust chain tension per Step 10A.

Trouble	Possible Cause	Remedy
Upon test, shutter does not close fully (Manual Lift-up and Crank)	*Clutch disks and sprockets not aligned correctly.	*Review orientation of clutch disks and sprockets per Step 10A.
Shutter will not close fully after successive drop tests	*Excessively loose chain (skipping sprocket teeth).	*Adjust chain tension per Step 10A.

19

APPENDIX D: COMPOUND TENSION ADJ. ASSEMBLY

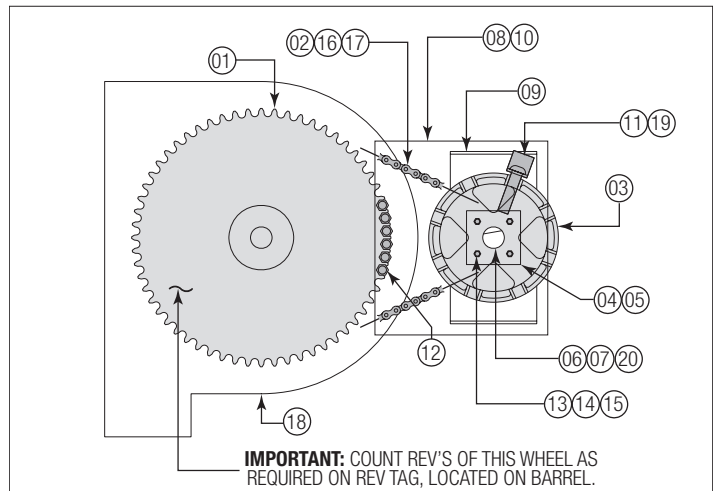

Item	QTY	Item	QTY		
01	1	Large Sprocket, (Size Varies)	11	1	Clip Angle, 4" x 2" x 1/4" x 2" Long
02	1	Small Sprocket, 13T, 1-1/2" Bore	12	6	Tap bolt, 1/2" - 13 x 2-1/2"
03	1	Adjuster: AW745 1-1/2" Bore	13	8	3/8" - 16 x 1-1/4" HHCS
04	2	Bearing retainer	14	8	Washer, Flat, 3/8"
05	2	Bearing, 1-1/2" ID	15	8	Hex Nut 3/8" - 16
06	1	Shaft, 9-1/2" x 1-1/2" Dia. (C1045)	16	1	Key, 3/8" x 3/8" x 1-1/4"
07	2	Shaft Collar, 1-1/2" ID	17	AR	Roller Chain, (Series and Length Vary)
08	1	Mounting Plate, 16" x 16" x 3/8", Steel	18	1	Adjusting Bracket

Item	QTY		Item	QTY	
09	1	Shaft Support Plate	19	1	Rivet, 3/4" x 3-1/2"
10	1	Tension Holder, 2" x 10" x 1/2" Bar	20	1	Pin, Cotter, 1/4" x 2-1/4", Steel

Use bolts (item #12) to lock large sprocket (item #01) into place after applying tension. The amount of initial tension is determined by the revolutions of the large sprocket.



BOLTS MUST BE IN PLACE BEFORE DOOR IS OPERATED. ROLLER CHAIN WILL NOT HOLD WEIGHT OF DOOR. FAILURE TO INSTALL ALL BOLTS WILL RESULT IN CHAIN BREAKING, ALLOWING DOOR TO FALL, CAUSING POSSIBLE SERIOUS INJURY OR DEATH.

ROLLING FIRE DOOR TEST DROP RELEASE FORM

Job Name: _____ Date: _____

WAYNE DALTON

CONTRACT NO :

The rolling fire door(s) installed on the above project by _____

_____ have been properly tested in my presence and in accordance with the Wayne Dalton installation instructions set forth in this manual. The door(s) release automatically and come down to a fully closed position.

Quantity of Firestar™ Fire Doors on this job: _____

Door Mark(s): _____

Tests Performed By: _____ Tests Witnessed By: _____

Title: _____

Company: _____

Date: _____

NOTE: This page is supplemental to the main form, included in the hardware bag. Copies of the main form should be forwarded to the specified locations .

**NOTICE
FIRE DOOR PERIODIC TEST REQUIREMENT**

This door has been installed and tested for proper operation according to procedures set forth in this manual to ensure that it performs as designed at the time of installation.

Date: _____
 _____ Installer

 _____ Phone

To Possessor of the Premises

The installer has certified that this door has been properly installed, that it has been tested, and that it performs as designed at time of installation. From now on, you should have it inspected regularly and tested periodically for any subsequent damage or wear which might preclude it from closing properly in event of a fire.

Date: _____ Tested By: _____

Fire Marshal

Be aware that the local Fire Marshal is the final authority on the installation and operation of a fire door. He may require steps not listed in NFPA 80 or these instructions.



FireStar® Rolling Steel Door and Operator System

Limited Warranty

Wayne Dalton, a division of Overhead Door Corporation ("Seller") warrants to the original purchaser of the FireStar® Rolling Steel Fire Door Models 700, 700C ("Door") and Genie commercial GCL-GH (for FireStar® doors) or GCL-H Fire Door Operator ("Operator") (Door and Operator purchased and installed together collectively referred to as the "System"), subject to all of the terms and conditions hereof, that the System and all components thereof will be free from defects in materials and workmanship for the following period(s) of time, measured from the date of installation:

- Seller warrants all parts and components of the System, except the counterbalance spring and finish, to be free from defects in materials and workmanship for three (3) years from the date of installation or 20,000 cycles¹, whichever occurs first.

Seller's obligation under this warranty is specifically limited to repairing or replacing, at its option, any part which is determined by Seller to be defective during the applicable warranty period. Repair or replacement labor for any defective System component is excluded and will be the responsibility of the purchaser.

This warranty is made to the original purchaser of the System only and is not transferable or assignable. This Product is intended for commercial and industrial applications only. Use in a non-approved application will void this warranty. This warranty does not apply to any unauthorized alteration or repair of the System, or to any System or component which has been damaged or deteriorated due to misuse, neglect, accident, failure to provide necessary maintenance, normal wear and tear, acts of God, or any other cause beyond the reasonable control of Seller. This warranty does not cover replacement batteries or apply to any damage or deterioration caused by door slats rubbing together as the door rolls up upon itself or caused by exposure to salt water, chemical fumes or other corrosive or aggressive environments, whether naturally occurring or man-made, including, but not limited to, environments with a high degree of humidity, sand, dirt or grease. This warranty applies only to Systems (a Door and Operator purchased and installed together simultaneously) and not to any Door or Operator purchased independently from the other, regardless of whether subsequently paired together.

THIS WARRANTY IS EXCLUSIVE AND IN LIEU OF ANY OTHER WARRANTIES, EITHER EXPRESS OR IMPLIED, INCLUDING BUT NOT LIMITED TO ANY IMPLIED WARRANTY OF MERCHANTABILITY OR FITNESS FOR A PARTICULAR PURPOSE.

IN NO EVENT SHALL SELLER BE RESPONSIBLE FOR, OR LIABLE TO ANYONE FOR, SPECIAL, INDIRECT, COLLATERAL, PUNITIVE, INCIDENTAL OR CONSEQUENTIAL DAMAGES, even if Seller has been advised of the possibility of such damages. Such excluded damages include, but are not limited to, loss of goodwill, loss of profits, loss of use, cost of any substitute product, interruption of business, or other similar indirect financial loss.

Claims under this warranty must be made promptly after discovery, within the applicable warranty period, and in writing to the authorized dealer or installer whose name and address appear below. The purchaser must allow Seller a reasonable opportunity to inspect any System claimed to be defective prior to removal or any alteration of its condition. Proof of the purchase and/or installation date, and identification as the original purchaser, may be required. This Warranty is not valid unless the fields below are completed by the installer at the time of installation.

¹The number of cycles referred to herein shall be measured by an integrated cycle counter contained in or attached to the Operator. If the cycle counter is rendered inoperable, Seller shall use other reasonable means to determine the cycle count.

Door Type: _____

Operator Type: _____

Customer Name (Original Purchaser): _____

Customer Installation Location: _____

Order # _____ Date of Installation: _____

Name of Dealer/Installer: _____

Signature of Dealer/Installer: _____

Thank you for your purchase.

PLEASE DO NOT RETURN THIS PRODUCT TO THE STORE

Please Do Not Return This Product To The Store. Please call 1-866-569-3799 (Press Option 1) and follow the prompts to contact the appropriate customer service representative. They will be happy to handle any questions that you may have.

After installation is complete, fasten this manual near garage door for easy reference.

Product may be covered by one or more patents.
See **www.wayne-dalton.com/patents** for details.