

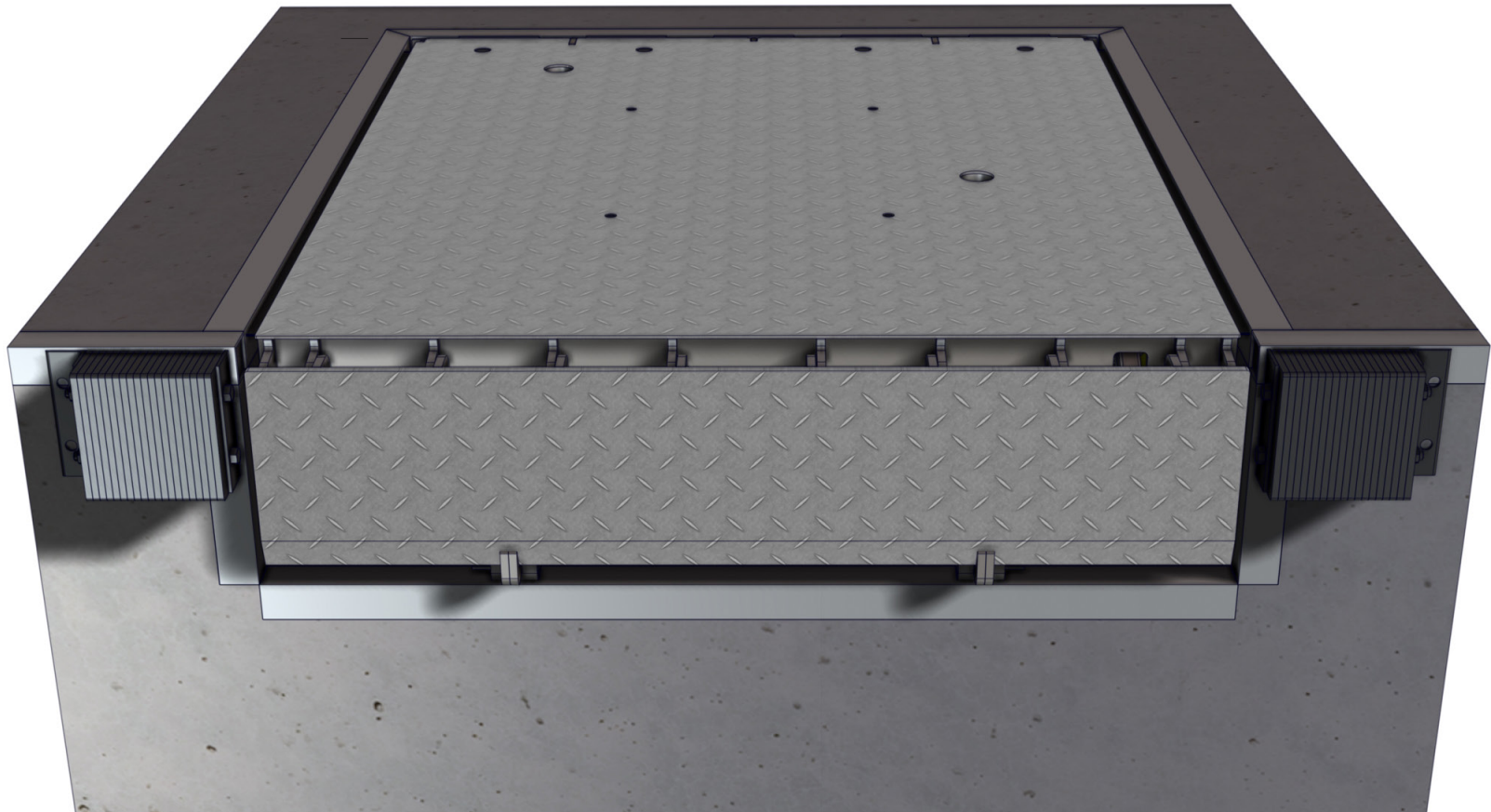

Dalton Dock™



**OPERATION MANUAL AND INSTALLATION INSTRUCTIONS
MECHANICAL PIT LEVELER MODEL M68WD AND M78WD**

READ COMPLETE INSTRUCTIONS BEFORE INSTALLING DOCK LEVELERS

TABLE OF CONTENTS

| | |
|---|--------------|
| Safety Information | 3-5 |
| Terminology And Definitions | 3 |
| Precautions | 4-5 |
| Operation | 6-11 |
| Operating Instructions | 6-7 |
| Owner / User Responsibilities | 8-11 |
| Pit Leveler Dimensions | 12-13 |
| Installation Instructions | 14-22 |
| Installation Precautions | 14 |
| Installation Instructions | 15-22 |
| Testing And Spring Adjustments | 23-25 |
| Troubleshooting | 26-28 |
| Maintenance | 29-31 |
| Replacement Parts | 32-48 |
| Warranty | 49 |

TERMINOLOGY AND DEFINITIONS

Important Safety Instructions

DEFINITION OF KEY WORDS USED IN THIS MANUAL:



INDICATES A HAZARDOUS SITUATION THAT, IF NOT AVOIDED, WILL RESULT IN DEATH OR SERIOUS INJURY.



INDICATES A HAZARDOUS SITUATION THAT, IF NOT AVOIDED, COULD RESULT IN DEATH OR SERIOUS INJURY.



INDICATES A HAZARDOUS SITUATION THAT, IF NOT AVOIDED, COULD RESULT IN MINOR OR MODERATE INJURY.



INDICATES INFORMATION CONSIDERED IMPORTANT, THAT IT IS NOT RELATED TO INJURY, BUT MAY RESULT IN PROPERTY DAMAGE.

IMPORTANT: Required key step for proper dock operation.

NOTE: Information only.

PRECAUTIONS

Operational Precautions

Read and understand these instructions to ensure safe installation and operation of the equipment.

DANGER

DO NOT STAND BETWEEN TRANSPORT VEHICLE AND DOCK LEVELING DEVICE WHEN TRANSPORT VEHICLE IS ENTERING OR LEAVING THE AREA. GETTING PINNED BETWEEN THE TRANSPORT VEHICLE AND THE LEVELER WILL CAUSE DEATH OR SERIOUS INJURY.

DANGER

DOCK LEVELER SWINGS WITH CONSIDERABLE FORCE. ACTUATING THE DOCK LEVELING DEVICE WITH ANYONE UNDER OR IN FRONT OF IT WILL CAUSE DEATH OR SERIOUS INJURY.

DANGER

KEEP HANDS, FEET AND OTHER APPENDAGES CLEAR OF HINGES AND OTHER PINCH POINTS WHEN MOVING, INSTALLING, OPERATING, SERVICING, OR OTHERWISE MANIPULATING THE DOCK LEVELING DEVICE. THIS DEVICE IS HEAVY AND MOVES WITH CONSIDERABLE FORCE, CAPABLE OF SEVERING APPENDAGES AND CAUSING SERIOUS INJURY OR DEATH.

DANGER

TOTAL WEIGHT OF LOADING VEHICLE AND LOAD SHOULD NEVER EXCEED THE DYNAMIC LOAD CAPACITY LISTED ON THE SERIAL # & MODEL TAG. OVERLOADING A DOCK LEVELING DEVICE BEYOND ITS MANUFACTURER RATED DYNAMIC CAPACITY WILL DAMAGE IT OR CAUSE IT TO COLLAPSE, WHICH MAY RESULT IN DEATH, SERIOUS INJURY AND/OR DAMAGE TO EQUIPMENT.

WARNING

CHOCK/RESTRAIN ALL TRANSPORT VEHICLES. NEVER REMOVE THE WHEEL CHOCKS OR RELEASE THE RESTRAINING DEVICE UNTIL LOADING OR UNLOADING IS FINISHED, AND THE TRANSPORT VEHICLE DRIVER HAS BEEN ALERTED. DEATH OR SERIOUS INJURY MAY OCCUR IF THE TRANSPORT VEHICLE INADVERTENTLY SLIPS AWAY FROM THE DOCK DURING LOADING/ UNLOADING.

WARNING

DO NOT USE A BROKEN OR DAMAGED DOCK LEVELING DEVICE OR RESTRAINING DEVICE. ENSURE ATTACHMENT WELDS ARE NOT CRACKED AND PROPER SERVICE AND MAINTENANCE PROCEDURES HAVE BEEN PERFORMED BEFORE USING. A DAMAGED OR DETACHED DOCK LEVELING DEVICE MAY COLLAPSE, CAUSING DEATH OR SERIOUS INJURY.

WARNING

ENSURE THE LIP HORIZONTALLY OVERLAPS THE TRANSPORT VEHICLE BY AT LEAST 4 INCHES (102 MM) BEFORE DRIVING ONTO THE DOCK LEVELING DEVICE. USING A LEVELER WITHOUT SUFFICIENT OVERLAP MAY RESULT IN THE LIP SLIPPING OFF OF THE TRANSPORT VEHICLE AND COLLAPSING, WHICH MAY CAUSE DEATH OR SERIOUS INJURY.

WARNING

MAINTAIN A SAFE DISTANCE FROM BOTH SIDE EDGES WHEN DRIVING ONTO A DOCK LEVELING DEVICE. FALLING OFF THE DOCK LEVELING DEVICE MAY RESULT IN DEATH OR SERIOUS INJURY.

WARNING

USING A DOCK LEVELING DEVICE ABOVE OR BELOW THE ALLOWABLE VERTICAL WORKING RANGE MAY CAUSE IT TO COLLAPSE, CREATE PINCH POINTS, OR CAUSE DANGEROUS LIP RISE, WHICH MAY CAUSE DEATH OR OTHER SERIOUS INJURY.

WARNING

OPERATING MATERIAL HANDLING OR DOCK EQUIPMENT WHILE UNDER THE INFLUENCE OF DRUGS OR ALCOHOL MAY RESULT IN DEATH OR SERIOUS INJURY.

WARNING

DO NOT EXCEED 5 MPH WHEN DRIVING ON OR ACROSS A DOCK LEVELING DEVICE. DO NOT STOP OR ACCELERATE ABRUPTLY WHEN LOADING VEHICLE WHEELS ARE ON THE LIP OR PLATFORM. DRIVE SLOW AND STEADY ACROSS THE DOCK LEVELING DEVICE. FAILURE TO COMPLY COULD CAUSE THE DOCK LEVELING DEVICE TO COLLAPSE, RESULTING IN DEATH OR SERIOUS INJURY.

CAUTION

NEVER LEAVE UNATTENDED EQUIPMENT, VEHICLES, OR MATERIALS ON DOCK LEVELING DEVICE.

PRECAUTIONS CONTINUED...

Operational Precautions Continued...

⚠ DANGER

KEEP HANDS, FEET AND OTHER APPENDAGES CLEAR OF HINGES AND OTHER PINCH POINTS WHEN MOVING, INSTALLING, OPERATING, SERVICING, OR OTHERWISE MANIPULATING THE DOCK LEVELING DEVICE. THIS DEVICE IS HEAVY AND MOVES WITH CONSIDERABLE FORCE, CAPABLE OF SEVERING APPENDAGES AND CAUSING SERIOUS INJURY OR DEATH.

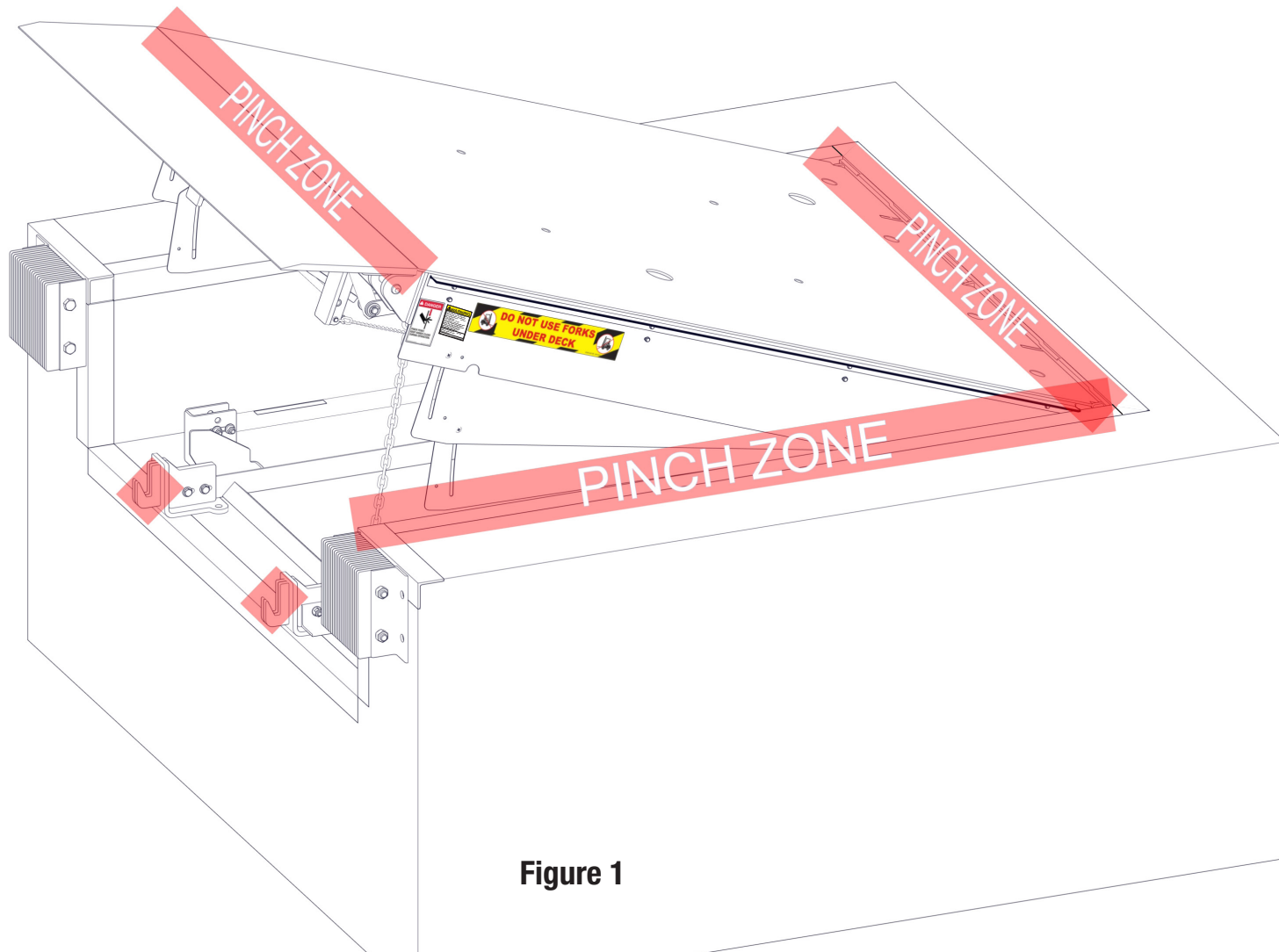

Figure 1

OPERATING INSTRUCTIONS

NOTE: Model M68WD 35K shown in all figures for reference.

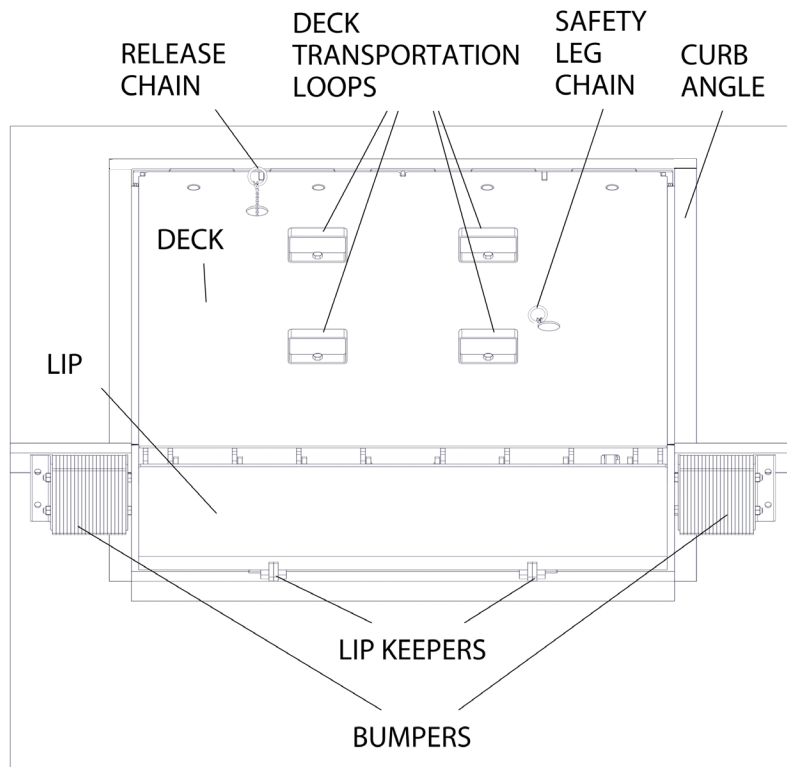

Figure 2

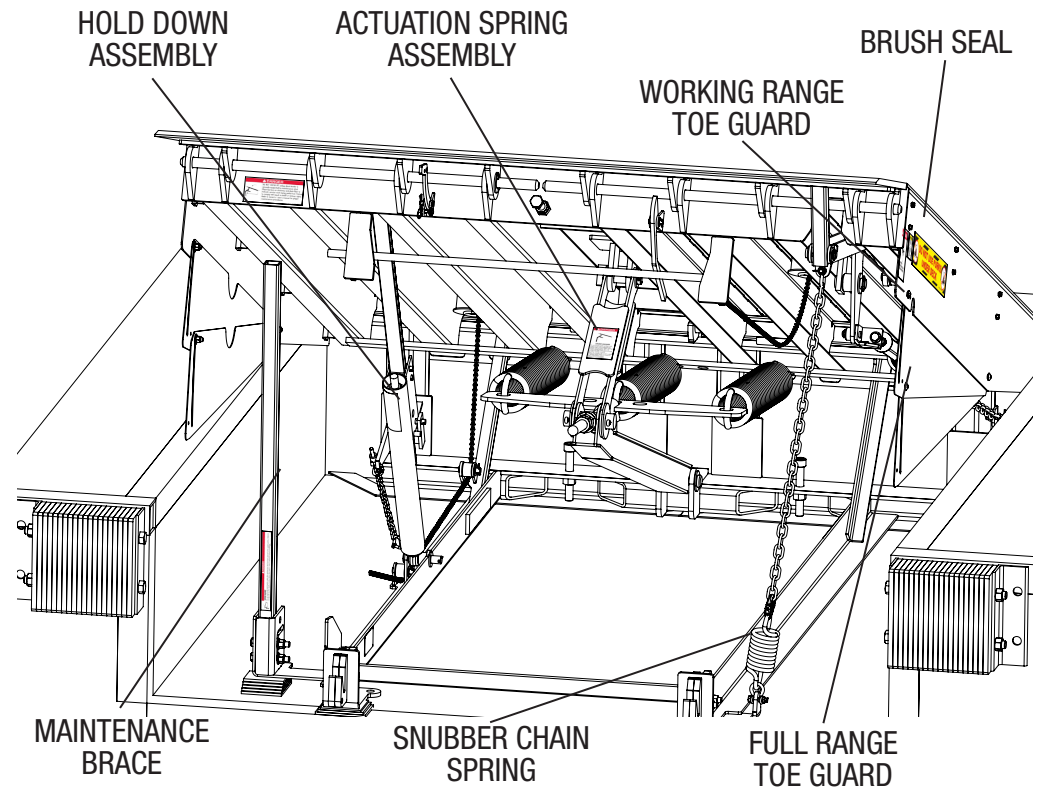

Figure 3

OPERATING INSTRUCTIONS CONTINUED...

DANGER

Read and follow all instructions, warnings and maintenance schedules in the manual.

- Always chock trailer wheels or engage trailer restraint before operating dock leveler or beginning to load or unload.
- Never use hands or equipment to move ramp or lip. Using material handling equipment to lower ramp will cause premature wear or damage to the dock leveling device.
- Ensure truck bed supports extended lip or leveler frame supports the ramp before driving on ramp.
- Stay clear of hinges and front and sides of moving dock leveler.
- Never use damaged or malfunctioning dock leveler. Report problems immediately to supervisor.
- DO NOT ENTER THE PIT unless dock leveler is securely supported by maintenance brace and a second means of bracing.

FAILURE TO FOLLOW THESE INSTRUCTIONS WILL RESULT IN DEATH OR SERIOUS INJURY.

WARNING

- Operation and servicing of dock leveler is restricted to authorized personnel.
- Before activating dock leveler:
 - Ensure trailer is backed up against bumpers.
 - Remove any end load, if required.
 - Check trailer alignment to avoid lip interference. If lip does not lower to trailer bed, reposition vehicle.
- Before allowing vehicle to leave the dock always:
 - Ensure no equipment, material or people are on dock leveler.
 - Return dock leveler to its stored position at dock level.

FAILURE TO FOLLOW THESE INSTRUCTIONS COULD RESULT IN DEATH OR SERIOUS INJURY.

EXTENDING THE LEVELER ONTO BED OF TRANSPORT VEHICLE

1. Standing on the warehouse door, grasp the ring connected to the release chain and pull, holding the ring and chain taut while the platform reaches the fully raised position. Release the ring.
2. Carefully, walk out onto the platform of dock leveler. This will allow the dock to lower, resting its lip onto the transport vehicle.

IMPORTANT: The permitted total gross weight (Load + Loading Equipment [eg: forklift, pallet mover, etc.]) traversing the leveler should not exceed the Dynamic Capacity of the leveler. The Dynamic Capacity is listed as ##K DYN on the SERIAL # & MODEL TAG under "CAPACITY", where ## is the total gross weight in thousands of pounds.

BELOW DOCK ENDLOADING

1. Standing on the warehouse floor, grasp the ring connected to the release chain and pull, holding the ring and chain taut while the platform reaches the fully raised position. Release the ring.
2. Walk onto the platform, not allowing the lip to fold down. Pull and hold the safety leg chain ring which is located towards the lip-end of the dock leveler. Keep this chain taut until the leveler descends into the below-dock position. Release the safety leg pull chain ring when the dock leveler lip is resting between the building and the transport vehicle.

RETURNING LEVELER TO STOWED POSITION

1. Grasp the ring connected to the release chain and pull, holding the ring and chain taut while the platform reaches the fully raised position. Release the ring.
2. Slowly walk the platform down, allowing the lip to fold down and clear the transport vehicle. Continue to walk toward the end of the platform, until the lip is resting inside the lip keepers and the platform is parallel with the warehouse door.

OWNER / USER RESPONSIBILITIES

GENERAL

Like other industrial devices, misuse and improper maintenance of dock leveling devices can result in injury or death.

APPLICATION CONSTRAINTS

Use of a dock leveling device shall take application constraints into consideration; including, but not limited to:

- a) Site Considerations:
 1. Driveway grades.
 2. Pit and bumper projections.
 3. Loading dock height.
- b) Transport Vehicle Considerations.
 1. Tractor operations.
 2. Shunt truck or yard jockey operations.
- c) Material Handling Equipment Considerations:
 1. The heaviest material handling equipment and load.
 2. The distribution of weight between the material handling equipment's front and rear axles.
 3. Gross vehicle weight (GVW) being driven across the dock leveler.
 4. The number of cycles driven across the dock leveler.
 5. The speed of material handling equipment moving across the dock leveler.
 6. The use of three-wheel vs. four-wheel fork trucks.
 7. Attachments on the front end of the material handling equipment.
 8. The direction of material handling equipment travel.
- d) Dock Leveler Considerations:
 1. The life expectancy of the dock leveler.
 2. The loading slope above or below dock leveler.
 3. The lip length.

In selecting dock leveling devices, it is important to consider present requirements, future plans and adverse environmental conditions.

The owner/user shall provide application information to the manufacturer to receive recommendations on appropriate equipment specifications and capacity.

INSTALLATION

PLACARDS AND WARNINGS

The owner/user shall ensure that the following are in place, legible, and available to operators:

- Nameplates
- Instruction Placards
- Safety Signs Or Labels
- Operating And Maintenance Manuals

The owner/user shall obtain replacement nameplates, instruction placards, safety signs or labels, and manuals from the manufacturer, if needed. Placards, markings, and labels should not be obscured from the view of operating or maintenance personnel for whom Such information are intended.

FIXED LEVELING DEVICES

If the dock leveling device is recessed in a concrete pit, the top three sides of the recess and driveway end of pit floor shall have steel angles or channels anchored into the concrete as recommended by the dock leveling device manufacturer.

FIXED TYPE

A fixed type is a structure designed for stationary mounting to the dock, located at either the dock face or recessed into a pit. Placement of the bridging structure into a working or stored position will usually be aided by a mechanism incorporated into the design.

MODIFICATIONS TO DOCK LEVELING DEVICES

Dock leveling devices can become hazardous if the manufacturer's instructions regarding modifications or adjustments are not followed.

Modifications or alterations of dock leveling devices shall be made only with written permission of the original manufacturer. These changes shall be in conformance with all applicable provisions of the latest ANSI MH30.1 standard and shall also satisfy all safety recommendations of the original equipment manufacturer for the particular application.

Modifications or additions that affect capacity and appropriate dock leveling device operation shall not be performed without manufacturer's prior written approval.

OWNER / USER RESPONSIBILITIES CONTINUED...

INFORMATION FOR USE

The owner/user shall verify that the material listed in this manual have been received, and that the information contained herein is made available for the instruction and training of personnel entrusted with the installation, operation or maintenance of the dock leveling device.

LOADING DOCK OPERATING PERSONNEL TRAINING

The owner/user should recognize the inherent danger of the interface between dock and transport vehicle. The owner should, therefore, train and instruct loading dock operating personnel in the proper use of dock leveling devices in accordance with information provided by the manufacturer.

An effective loading dock operating personnel training program should focus on the user company's policies, operating conditions, and the manufacturer's specific instructions that were provided with the dock leveling device. The complete training program should be presented to all new operators and not condensed or eliminated for those claiming previous experience.

The loading dock operating personnel training program should consist of, but not necessarily be limited to, the following:

- a) Select the operator carefully. Consider physical qualifications, job attitude and aptitude.
- b) Assure that the operator reads and fully understand the complete manufacturer's instruction manual.
- c) Emphasize the impact of proper operation upon the operator, other personnel, material being handled, and equipment. Cite all rules and why they are formulated.
- d) Describe the basic fundamentals of dock leveling device and component design as related to safety, e.g., mechanical limitations, stability, etc.
- e) Introduce the equipment. Show control locations and demonstrate functions. Explain how they work when used properly and problems when they are used improperly.
- f) Assure that the operator understands the capacity rating and other nameplate data, including the operator instructions and all precautionary information appearing on the dock leveling device.
- g) Supervise operator practice of equipment operation.
- h) Develop and administer written and practical performance tests. Evaluate progress during and at completion of the course.
- i) Administer periodic refresher courses. These may be condensed versions of the primary course and include on-the-job operator evaluation.

OPERATIONS

This clause contains broad operation standards applicable to dock leveling devices. Only operators trained to strictly adhere to the operating instructions stated in this clause shall be permitted to operate dock leveling devices. Unusual operating conditions may require additional precautions and special instructions.

The dock leveling device shall not be used outside its vertical working range or outside the manufacturer's labeled rated capacity. It shall also be compatible with the loading equipment and other conditions relating to dock activities.

The owner/user should recognize the inherent danger of the interface between the dock and the transport vehicle. The owner/user shall ensure that operators fully understand that proper operation is the operator's responsibility. The owner/user shall also ensure that operators are fully knowledgeable of, and observe, the operation rules and practices in this clause.

Proper operation of dock leveling devices is the responsibility of the operator. The operator shall have an ability to assess the working conditions and environment around the loading dock and an aptitude for identifying possible issues related to the process and use of the equipment.

Only authorized personnel shall be permitted to operate a dock leveling device. Operators shall be qualified as to visual, auditory, physical, and mental ability to operate the device safely in accordance with the manufacturer's instructions. The operator shall know, understand, and follow the manufacturer's operating instructions and all precautionary labeling on the dock leveling device. The operator shall develop working habits and the awareness of hazardous conditions that help to protect the operator, other personnel, the dock leveling device and other material associated with the task. The operator shall also know, understand, and follow the operation and function of all controls before undertaking operation of the dock leveling device.

OWNER / USER RESPONSIBILITIES CONTINUED...

TRANSPORT VEHICLE REQUIREMENTS

TRANSPORT VEHICLE POSITION

A dock leveling device shall be designed and installed so that when a transport vehicle is positioned as close as practicable to the loading dock, there shall be an overlap of at least 4 in. (102 mm) between the front edge of the lip of the dock leveler and the edge of the door or sill of the transport vehicle.

The loading dock area shall be designed so that the transport vehicle can be parked in a position relatively perpendicular to the dock face, centered with, and as close as practical to, the dock leveling device.

USE OF POSITIVE RESTRAINTS

When goods are transferred between the loading dock and the transport vehicle, the brakes on the transport vehicle shall be applied and wheel chocks or positive restraints that provide the equivalent protection of wheel chocks shall be engaged. Also, whenever possible, air-ride suspension systems should have the air exhausted prior to performing loading or unloading operations.

Refer to the latest ANSI MH30.3, Vehicle Restraining Devices: Performance and Testing for additional information on restraining the vehicle.

INSPECTION

Dock leveling devices may become hazardous if the manufacturer's instructions regarding maintenance, repairs, or adjustments are not followed.

All dock levelers shall be regularly inspected and maintained in conformance with good practice and the manufacturer instructions.

Dock leveling devices shall be kept in a clean condition to minimize fire hazards and facilitate detection of loose, worn, damaged or defective parts.

At the beginning of each shift and before operation of the dock leveling device, the operator shall inspect the condition of the dock leveling device, giving special attention to the following:

- a) Free of debris or obstruction
- b) Precautionary labeling intact and legible
- c) Guards or safety devices present and functional
- d) Controls fully operational
- e) Free of structural defect or damage
- f) All other items specified by the manufacturer.

Actuators (including springs, hydraulic cylinders, pneumatic cylinders, and air bags), valves, hoses, fittings, safety devices and other components shall be checked to ensure that nothing has developed to the extent that it would create a hazard or interfere with safe operation.

Special care should be taken on the inspection of pressure containing systems, including hoses.

Control mechanisms, fastening and warning devices, dock leveling device overload devices, guards and safety devices, deck, lip, and frame members shall be carefully and regularly inspected and maintained in accordance with the manufacturer's recommendations.

All electrical components including motors, switches, limit switches, indicator lights, protective devices, conductors, and connections shall be regularly inspected and maintained in conformance with good practices and the manufacturer's instructions. Special attention shall be paid to the condition of electrical insulation.

Manufacturer's recommended periodic maintenance and inspection procedures in effect at date of shipment shall be followed, and written records of the performance of these procedures should be maintained.

MAINTENANCE

Maintenance and inspection of all dock leveling devices shall be performed in conformance with the following practices. In addition, maintenance and inspection shall be performed in accordance with the manufacturer's recommendations.

- a) A scheduled planned maintenance program shall be followed.
- b) Only trained and authorized personnel shall be permitted to maintain, repair, adjust, and inspect dock leveling devices.
- c) Use only original equipment manufacturer parts, manuals, maintenance instructions and labels; or their equivalent.

DAMAGE

Dock leveling devices that are structurally damaged or have experienced a sudden loss of support while under load, such as might occur when a transport vehicle is pulled out from under the dock leveling device, shall be removed from service, inspected by the manufacturer's authorized representative, and repaired as recommended by the manufacturer before being placed back in service.

OWNER / USER RESPONSIBILITIES CONTINUED...

REPAIR

If the dock leveling device is found to require repair or cannot be used in its intended operating condition, the matter shall be reported immediately to the owner/user's designated authority. The dock leveler shall be taken out of service until it has been restored to an acceptable operating condition.

The operator shall not make repairs or adjustments unless specifically authorized and qualified to do so.

Before starting repair or inspection of a dock leveler device:

- a) Secure and restrict access in and around the dock position (dock and driveway)
- b) Read, understand, and follow all maintenance instructions provided by the dock leveling device manufacturer
- c) Follow all dock leveling device maintenance safety instructions
- d) Remove the load from the platform
- e) Disconnect power and follow established lockout/tag-out policies as required.

Avoid fire hazards and have fire protection equipment present in the work area. Do not use an open flame to check the level or to check for leakage of any fluid. Do not use open pans of fuel or flammable cleaning fluids for cleaning parts. Properly ventilate work area and keep it clean and dry. Care shall be taken to ensure that all replacement parts meet or exceed original equipment manufacturer's specifications.

CONFINED SPACE

If a confined space entry associated with operations or maintenance of a dock leveling device is required, the confined space procedures shall comply with ANSI/ASSP Z117.1.

PIT LEVELER DIMENSIONS

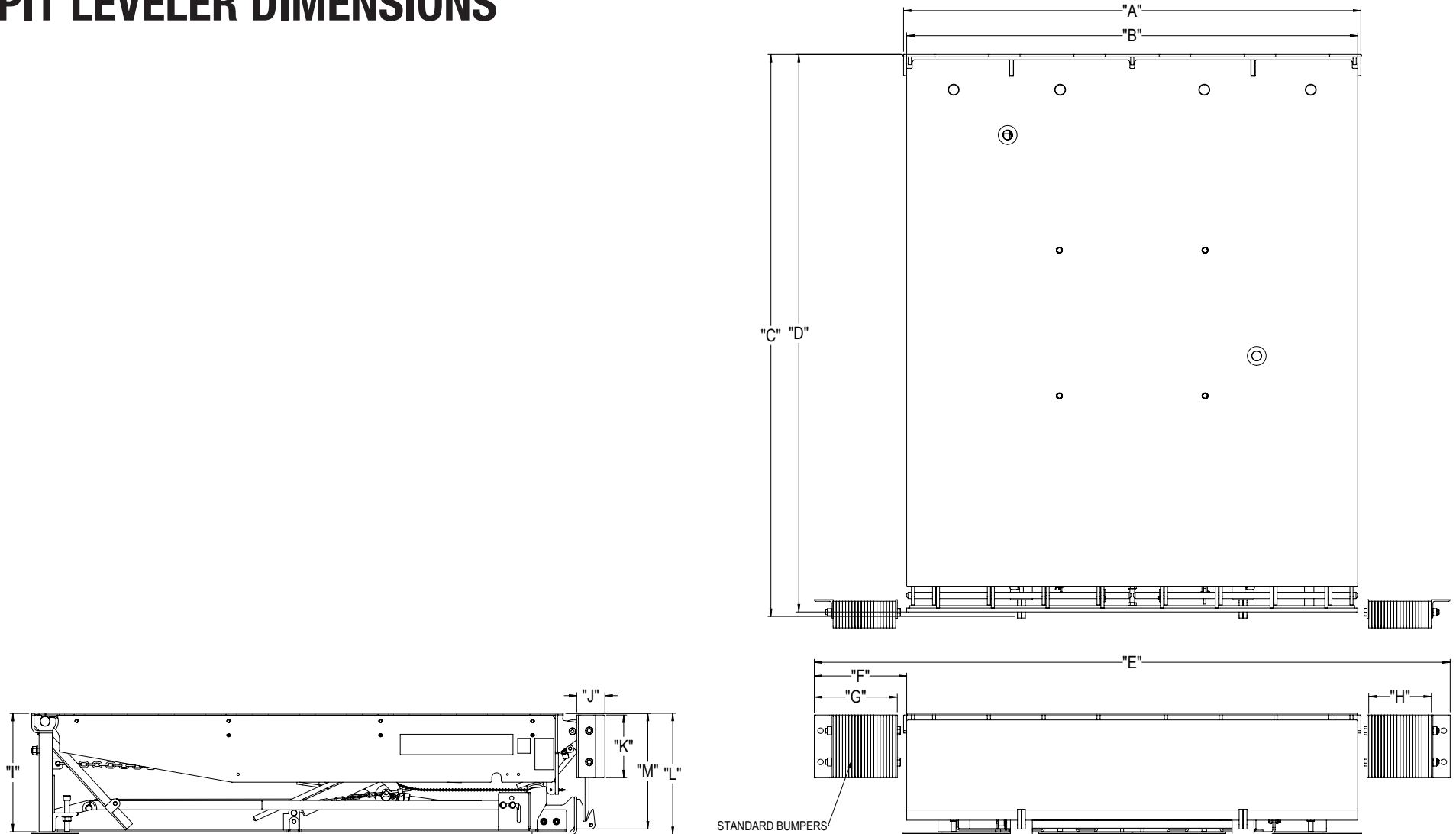

Figure 4

| DOCK LEVELER DIMENSIONS | | | | | | | | | | | | | |
|-------------------------|-------|-------|-------|-------|--------|-------|-------|-------|-------|------|-------|-------|--|
| MODEL # | "A" | "B" | "C" | "D" | "E" | "F" | "G" | "H" | "I" | "J" | "K" | "L" | |
| M68WD | 73.0" | 72.0" | 89.7" | 89.1" | 101.5" | 14.8" | 13.3" | 10.0" | 19.0" | 4.5" | 10.0" | 19.3" | |
| M78WD | 84.0" | 83.0" | 89.7" | 89.1" | 112.5" | 14.8" | 13.3" | 10.0" | 19.0" | 4.5" | 10.0" | 19.3" | |

| MODELS M68WD AND M78WD | |
|------------------------|-------|
| LIP SIZE (IN.) | "M" |
| 16" | 18.5" |
| 18" | 20.5" |
| 20" | 22.5" |

PIT LEVELER DIMENSIONS CONTINUED...

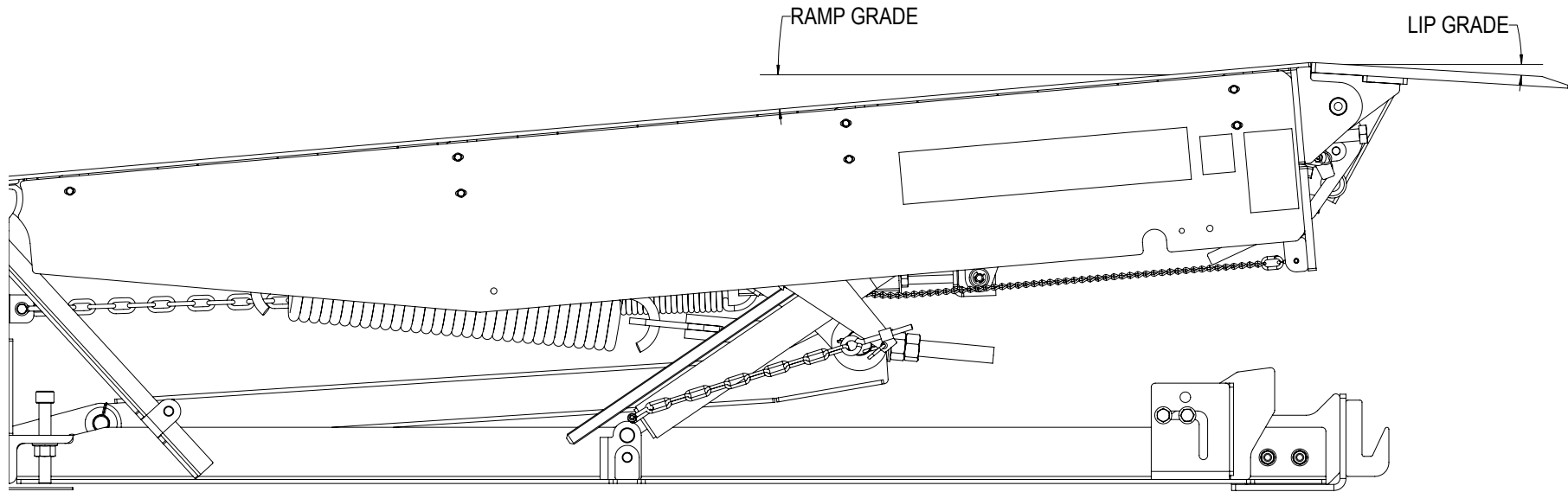

Figure 5

| RAMP AND LIP GRADES | | | |
|---------------------------------------|------------------------|-------|--------|
| LOADING VEHICLE HEIGHT FROM DOCK (IN) | RAMP AND LIP GRADE (%) | | |
| | | RAMP | LIP |
| ABOVE DOCK | 12 | 15.37 | 0.42 |
| | 10 | 13.25 | -1.66 |
| | 8 | 11.18 | -3.70 |
| | 6 | 9.14 | -5.73 |
| | 4 | 7.08 | -7.78 |
| | 2 | 5.05 | -9.82 |
| LEVEL | 0 | 3.00 | -11.89 |
| BELOW DOCK | -2 | 0.98 | -13.95 |
| | -4 | -1.05 | -16.02 |
| | -6 | -3.09 | -18.12 |
| | -8 | -5.12 | -20.22 |
| | -10 | -7.17 | -22.35 |
| | -12 | -9.22 | -24.51 |

INSTALLATION INSTRUCTIONS

Installation Precautions

DANGER

READ THESE INSTRUCTIONS CAREFULLY BEFORE ATTEMPTING INSTALLATION. IF YOU ARE IN QUESTION ABOUT ANY OF THE PROCEDURES, DO NOT PERFORM THE WORK. INSTALLATION OR REPAIRS SHOULD ONLY BE PERFORMED BY A TRAINED DOCK LEVELER SYSTEMS TECHNICIAN. FAILURE TO FOLLOW SAFETY INSTRUCTIONS WILL RESULT IN DEATH OR SERIOUS INJURY.

DANGER

KEEP HANDS, FEET AND OTHER APPENDAGES CLEAR OF HINGES AND OTHER PINCH POINTS WHEN MOVING, INSTALLING, OPERATING, SERVICING, OR OTHERWISE MANIPULATING THE DOCK LEVELING DEVICE. THIS DEVICE IS HEAVY AND MOVES WITH CONSIDERABLE FORCE, CAPABLE OF SEVERING APPENDAGES AND CAUSING SERIOUS INJURY OR DEATH.

WARNING

PROPER INSTALLATION OF THIS DEVICE REQUIRES THE USE OF SPECIAL TOOLS AND TECHNIQUES. ALWAYS USE THE CORRECT TOOLS OR TECHNIQUES WHEN PERFORMING INSTALLATION. FAILURE TO USE PROPER TOOLS OR TECHNIQUES OR ADHERE TO SAFETY MESSAGES, COULD RESULT IN DEATH OR SERIOUS INJURY.

WARNING

APPROPRIATE PERSONAL PROTECTIVE EQUIPMENT (PPE) SHOULD ALWAYS BE USED. THIS INCLUDES BUT IS NOT LIMITED TO A HARD HAT WHEN WORKING BELOW LEVELER DECK, APPROPRIATE EYE PROTECTION, GLOVES, AND HARD-CAPPED SLIP-RESISTANT FOOTWEAR WHEN WORKING ON OR NEAR THE DOCK AREA. APPROPRIATE PPE MAY PROTECT YOU FROM DEATH OR SERIOUS INJURY.

NOTICE

INSTALLATION OF THIS DOCK LEVELING DEVICE REQUIRES A MINIMUM OF TWO PEOPLE.

Required Tools And Materials List

- Lifting equipment
- Tape measure
- Welder with welding electrode or filler metal (minimum 70,000 PSI tensile strength)
- Wire brush (for cleaning weld slag and concrete splatter)
- Grinder (for removing powder coat before welding)
- Hammer drill with drill bit suitable for concrete. (Be sure to follow anchor manufacturer recommendation for hole diameter)
- Vacuum or compressed air (for concrete anchor hole clean out)
- Prybar
- Hammer or mallet (for driving concrete anchors)
- Drill driver with socket adapters (for installing anchors)
- 15" socket extension and a 5/8" hex bit socket (for leveling bolts)
- Calcium sulfonate complex grease
- Touch up paint (please see Replacement Parts on page 44.)
- 3/4" Wrench

INSTALLATION INSTRUCTIONS CONTINUED...

PRE-INSTALLATION TASKS

1. Ensure a site survey was completed prior to installation.
2. Verify embedded curb angles are present.
3. Check quality and condition of concrete and steel angles.
4. Check size, squareness, and plumbness of the pit. Be sure the pit conforms to the dimensions shown in **Figure 6**.
5. Prepare curb angle so it is smooth and clean of all slag and concrete.
6. Carefully clean out the pit of all dust and debris.

ATTACH LEVELING PLATES

1. Locate the two leveling plates in your package.
2. Place the leveling plates in the back of the pit, as shown in **Figure 7**.

NOTE: To prevent the leveling plates from shifting during installation of the leveler, the leveling plates are to be fastened to the pit floor with an appropriate adhesive.

NOTICE

INSTALLATION OF THIS DOCK LEVELING DEVICE REQUIRES A MINIMUM OF TWO PEOPLE.

WARNING

PLACE WARNING BARRICADES AROUND THE OUTSIDE OF THE EMPTY PIT, INSIDE AND OUTSIDE THE BUILDING, TO PREVENT INTRUSION DURING INSTALLATION.

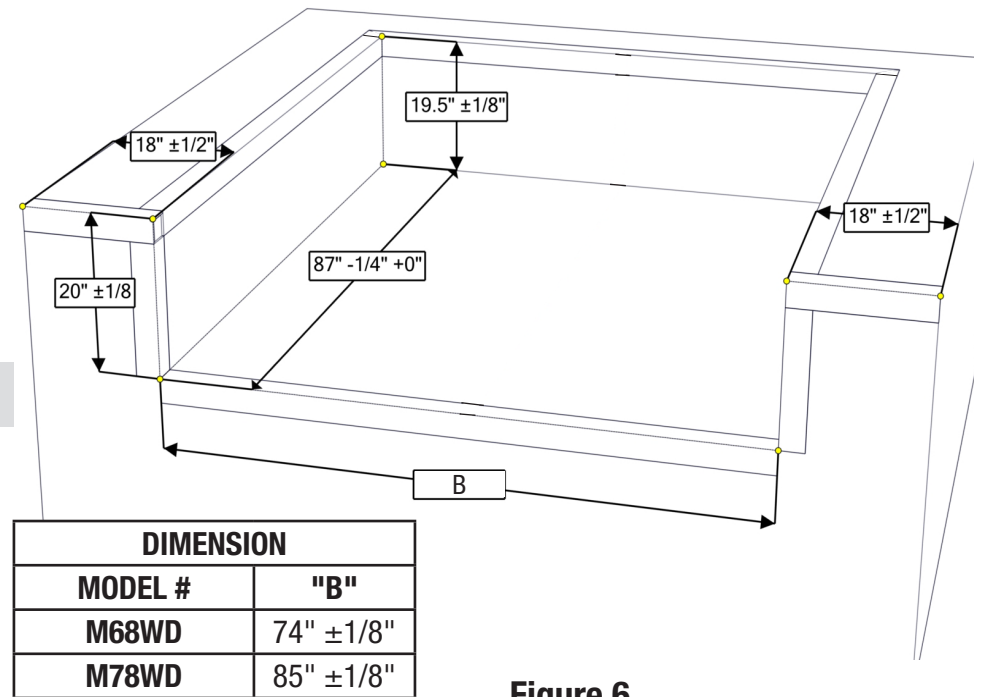

Figure 6

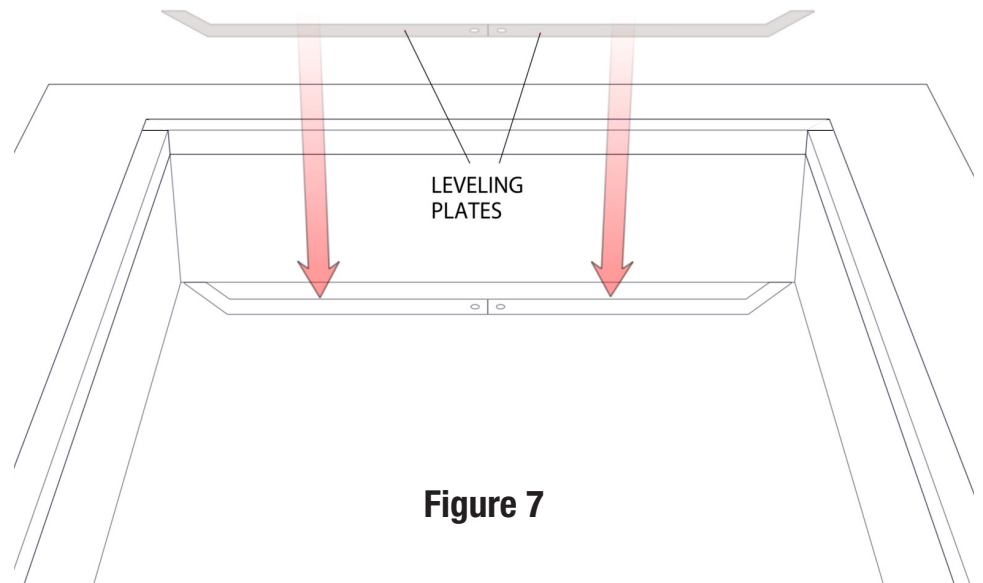

Figure 7

INSTALLATION INSTRUCTIONS CONTINUED...

LEVELER INSPECTION AND PREPARATION

1. Inspect leveler for damage before unloading.

IMPORTANT: Do not remove shipping clamps until instructed to do so.

2. Ensure the four deck transportation loops are installed and secure before lifting the leveler from the truck. See **Figure 8**.

NOTICE

DO NOT OVER-TIGHTEN DECK LOOPS, AS THIS WILL SCRAPE THE POWDER COAT OFF OF THE DOCK LEVELER AND RESTRICT THEIR MOVEMENT WHILE TRANSPORTING THE DOCK.

NOTICE

LIFTING THE LEVELER FROM UNDER THE DECK CAN RESULT IN SERIOUS DAMAGE TO THE LEVELER. ONLY LIFT THE LEVELER USING THE PROVIDED DECK TRANSPORTATION LOOPS.

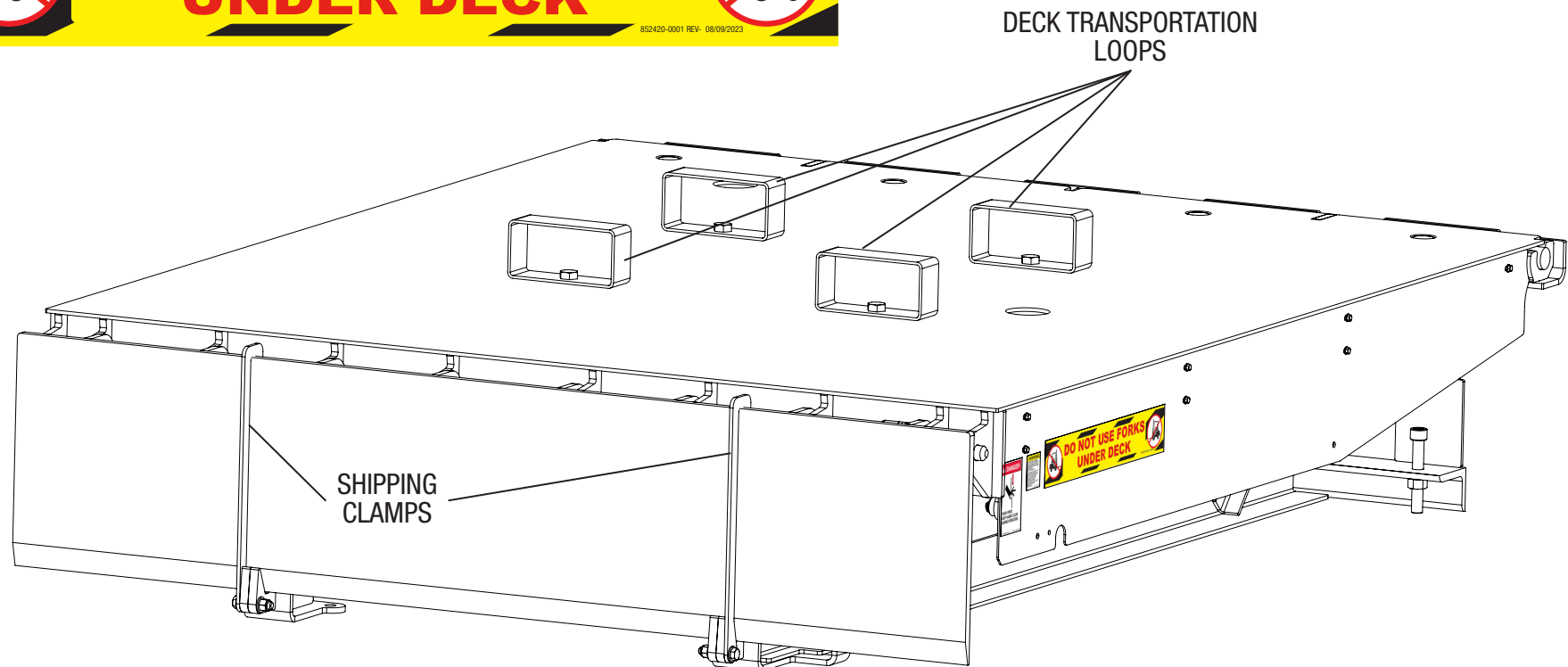

Figure 8

INSTALLATION INSTRUCTIONS CONTINUED...

⚠ DANGER

DO NOT ATTEMPT TO MOVE THE LEVELER BY HAND. USE CAUTION WHEN MOVING THE LEVELER INTO PLACE. NEVER WORK UNDER A LIFTED LEVELER. BE SURE ALL PERSONNEL ARE CLEAR OF THE INSTALLATION PATH BEFORE YOU BEGIN. ENSURE YOUR LIFTING EQUIPMENT IS RATED TO HANDLE AT LEAST 4000 POUND LOAD WEIGHT AND COMPLIES WITH ALL LIFTING REGULATIONS. FAILURE IN THESE POINTS WILL RESULT IN DEATH OR SERIOUS INJURY.

LEVELER INSTALLATION

1. Using properly rated lifting equipment lift the leveler using the deck transportation loops and lower it into the pit. See **Figure 9**.
2. Square the leveler in the pit and ensure the gap on each side is equal.

LEVELING THE REAR

1. Leveling bolts have been provided in the rear to help adjust the vertical position without shimming. Adjust the leveling bolts until the rear deck of the leveler is even with the warehouse floor. See **Figure 10**.

NOTE: Use a rotary power tool with at least a 15" socket extension and a 5/8" hex bit socket for the leveling bolts. It may be helpful to use tape to attach the socket to the end of the extension to prevent losing the socket under the deck.

NOTE: If a gap is observed between the rear embedded curb angle and the top of the leveler frame, first ensure the leveler is pushed all the way rearward, contacting the rear pit wall. Then, carefully lift the front (lip side) of the leveler to close the gap.

2. Tack weld the rear of the leveler to the rear curb angle to hold it in place.
3. Remove the shipping clamps and discard.
4. Recheck the gap on each side and ensure it is equal. The deck may have shifted to one side when the shipping clamps were removed. Adjust as needed.
5. If the pit is not square it may be necessary to add shims between the rear of the leveler and the rear pit curb angle. If this is needed, fill all gaps with weld.

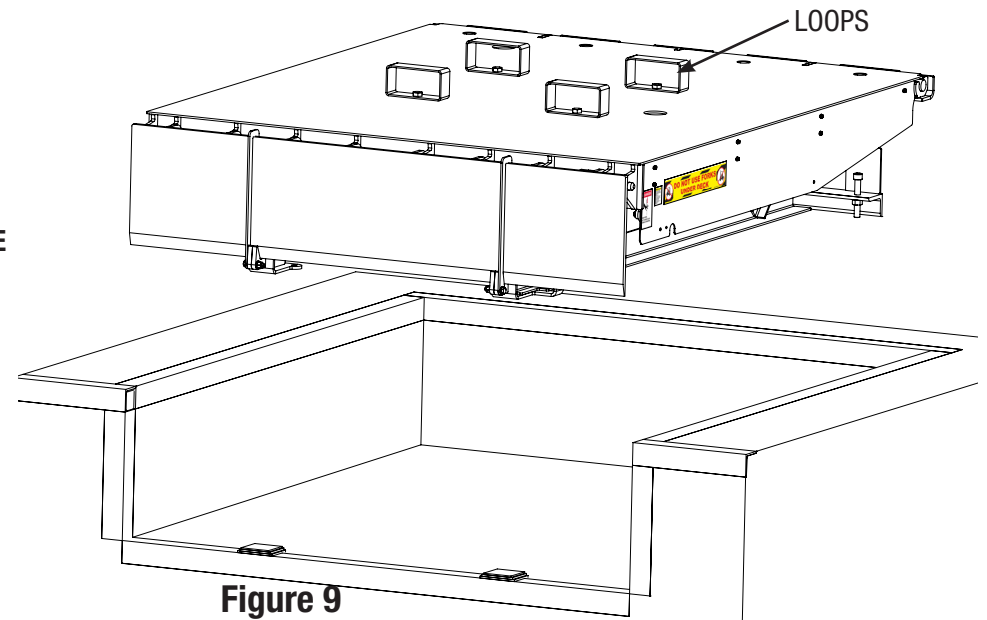

Figure 9

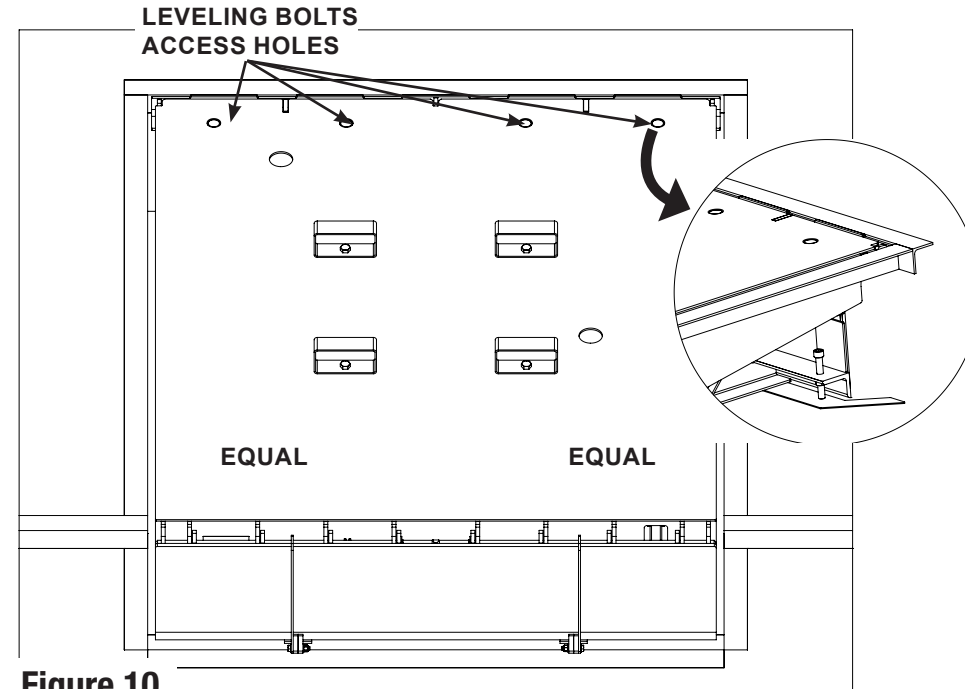

Figure 10

INSTALLATION INSTRUCTIONS CONTINUED...

WELD REAR OF LEVELER IN PLACE

1. Remove the paint from the rear of the leveler at the factory cut slots and from the curb angle with an angle grinder or equivalent.

IMPORTANT: If applicable, ensure that the Rear Seal (Brush) is removed from leveler prior to welding. Re-install the Rear Seal (Brush) after the welds have cooled.

2. Weld leveler to the rear curb angle using the factory cut welding slots, as shown in **Figure 11** and **Figure 12**.

3. Set the leveling bolts by turning them clockwise and torque to 40-60 ft. lbs.

IMPORTANT: Ensure all leveling bolts are contacting the leveling plates and equally torqued down.

OPEN THE LEVELER

1. Pull the release chain and allow the leveler to rise to the fully open position.

! DANGER

DOCK LEVELER SWINGS WITH CONSIDERABLE FORCE. ACTUATING THE DOCK LEVELING DEVICE WITH ANYONE UNDER OR IN FRONT OF IT WILL CAUSE DEATH OR SERIOUS INJURY.

! DANGER

KEEP HANDS, FEET AND OTHER APPENDAGES CLEAR OF HINGES AND OTHER PINCH POINTS WHEN MOVING, INSTALLING, OPERATING, SERVICING, OR OTHERWISE MANIPULATING THE DOCK LEVELING DEVICE. THIS DEVICE IS HEAVY AND MOVES WITH CONSIDERABLE FORCE, CAPABLE OF SEVERING APPENDAGES AND CAUSING SERIOUS INJURY OR DEATH.

2. Raise the lip brace and maintenance brace to their vertical and locked positions, as shown in **Figure 13**.

Secure it with an 5/8-inch diameter OSHA approved locking device. A secondary means of supporting the deck should be used.

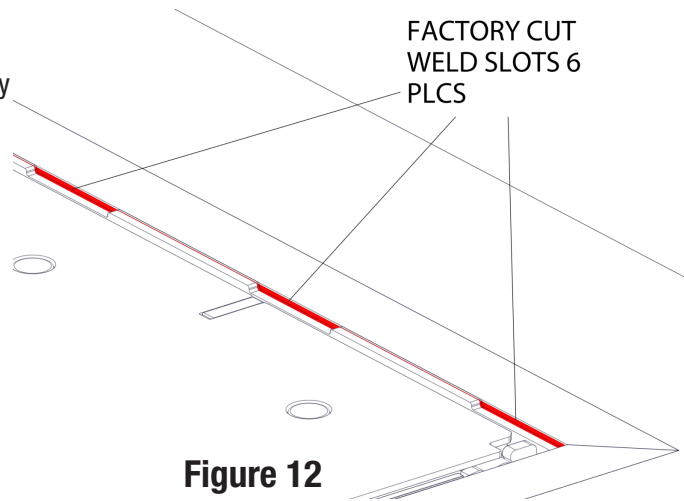

Figure 12

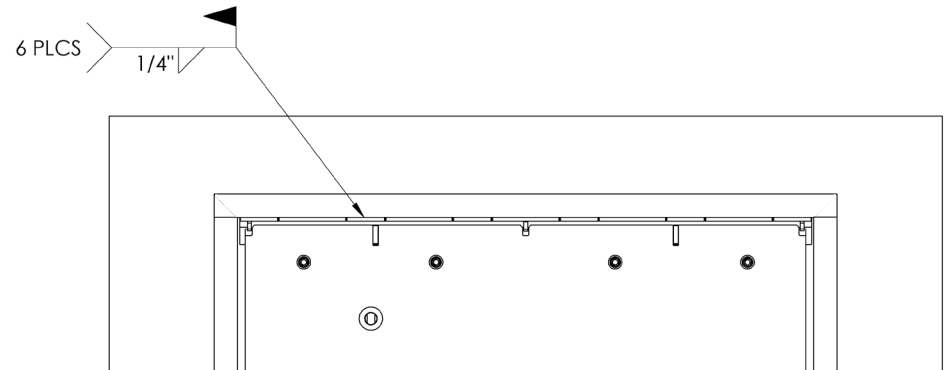

Figure 11

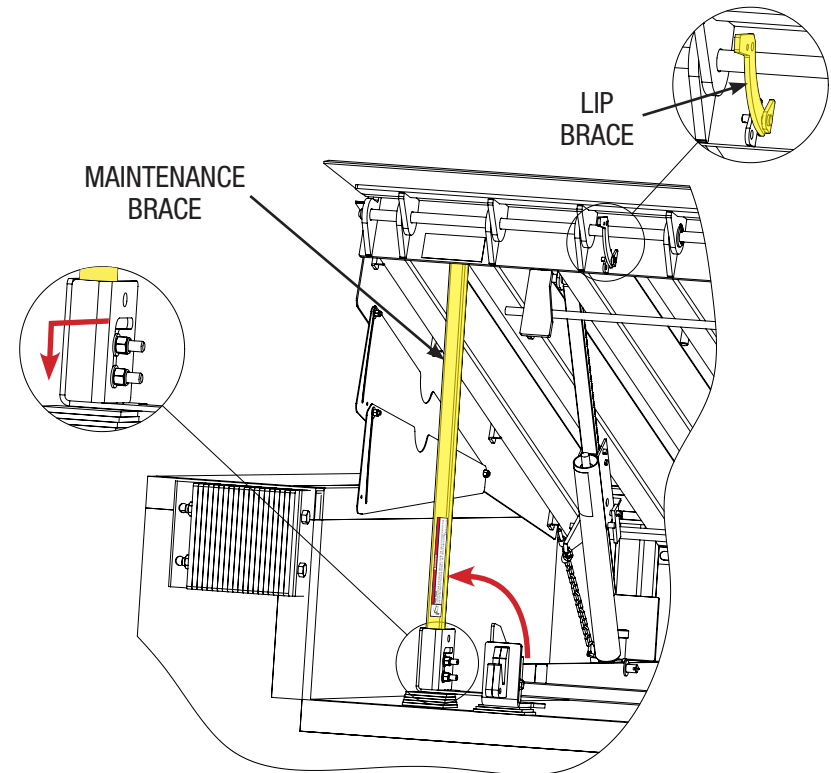

Figure 13

INSTALLATION INSTRUCTIONS CONTINUED...

⚠ DANGER

TO AVOID GETTING IMPACTED BY OR CRUSHED BELOW A FALLING DOCK LEVELER DEVICE, DO NOT WORK UNDERNEATH THE DECK OR LIP UNLESS MAINTENANCE BRACE HAS BEEN SECURED IN THE UPRIGHT POSITION. A SECONDARY MEANS OF SUPPORTING THE DECK SHOULD BE USED. FAILURE TO COMPLY WILL RESULT IN DEATH OR SERIOUS INJURY.

WELD FRONT OF LEVELER

1. Shim below lip keepers and maintenance brace, using a prybar to lift the front of the leveler up to insert the shims, as shown in **Figure 14**. The leveler must be shimmed until the front of the deck is level with or just below dock height when the leveler is stowed.

NOTE: With standard length lips, the shims beneath the lip keepers may be inserted with the leveler in the stowed position. With extended lips, the leveler must be raised to insert the shims.

⚠ DANGER

DO NOT ATTEMPT TO LIFT THE FRONT OF THE LEVELER BY HAND WHEN INSERTING SHIMS BELOW THE LIP KEEPERS AND MAINTENANCE BRACE. LEVELER WEIGHT IS CONSIDERABLE, AND THE LEVELER COULD SHIFT UNEXPECTEDLY. USE A SUFFICIENTLY LONG PRYBAR TO AVOID SEVERING FINGERS.

2. Ensure lip keeper bolts are fully torqued down.
3. Weld front frame angle, curb angle, and shims together, as shown in **Figure 14**.
4. Lower the maintenance brace and walk the leveler down to the closed position.

NOTICE

TO PROMOTE WELD PENETRATION, USE AS FEW AND AS THICK OF SHIMS AS POSSIBLE TO ACHIEVE DESIRED HEIGHT. DO NOT STACK MULTIPLE LAYERS OF THIN GAUGE SHIM. THE TOP SHIM IN THE STACK MUST BE AT LEAST 4" X 4" TO FULLY SUPPORT THE FRAME RAIL.

| Shim Stacking Methods | Lip Keepers | Maintenance Brace |
|-----------------------|----------------|-------------------|
| Straight | Not Acceptable | Not Acceptable |
| Stepped | Not Acceptable | Acceptable |
| Pyramid | Acceptable | Acceptable |
| Offset | Not Acceptable | Acceptable* |

* Acceptable only when load is supported by shims directly beneath it. Do not use overhanging shims to support a load.

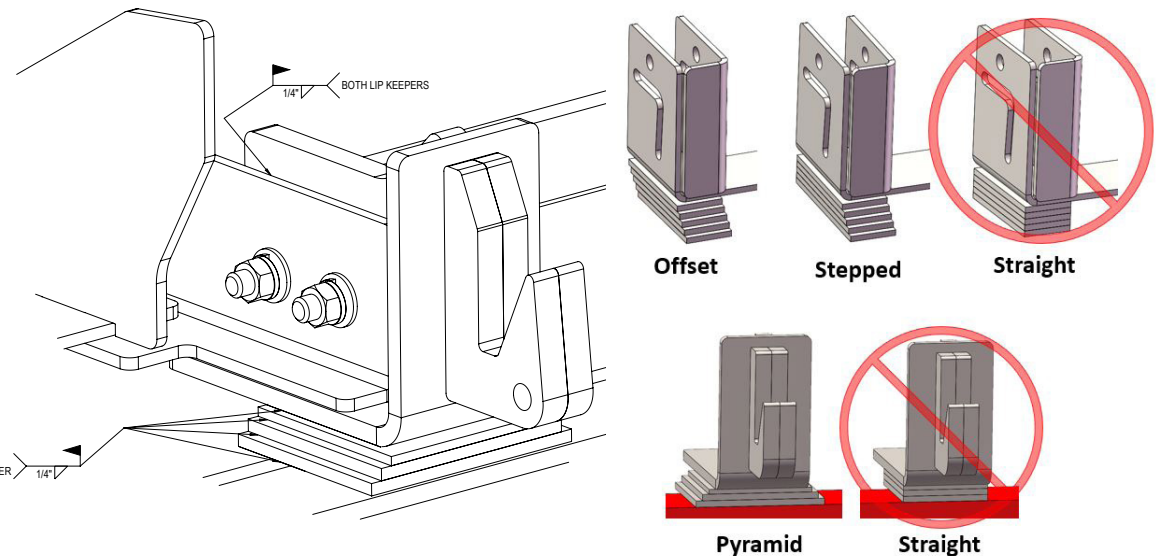

Figure 14

INSTALLATION INSTRUCTIONS CONTINUED...

INSTALL LAMINATED BUMPERS

1. Bumpers should be installed 46" - 52" from the top of the bumper to the ground.
2. Installation will be accomplished by a combination of welding and concrete anchors, as shown in **Figure 15** and **Figure 16**.
3. Follow concrete anchor manufacturer's instructions for proper use.

NOTICE

DO NOT USE A DOCK LEVELER WITHOUT BUMPERS INSTALLED. TO DO SO COULD RESULT IN DAMAGE TO THE LEVELER OR THE BUILDING.

FINISHING

1. Clean up welds and the surrounding area.
2. Apply rust inhibiting touch up paint to all welds and shims as necessary.

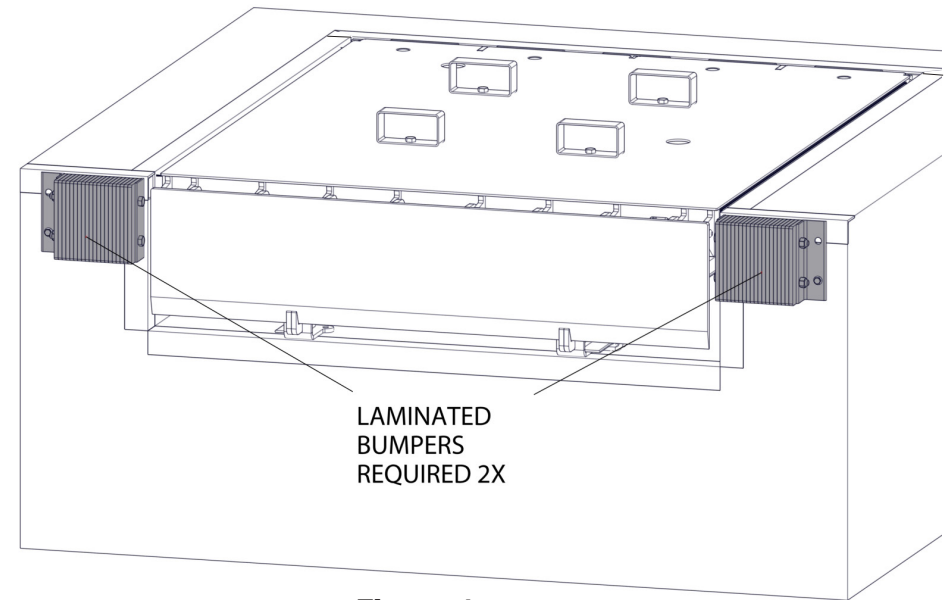

Figure 15

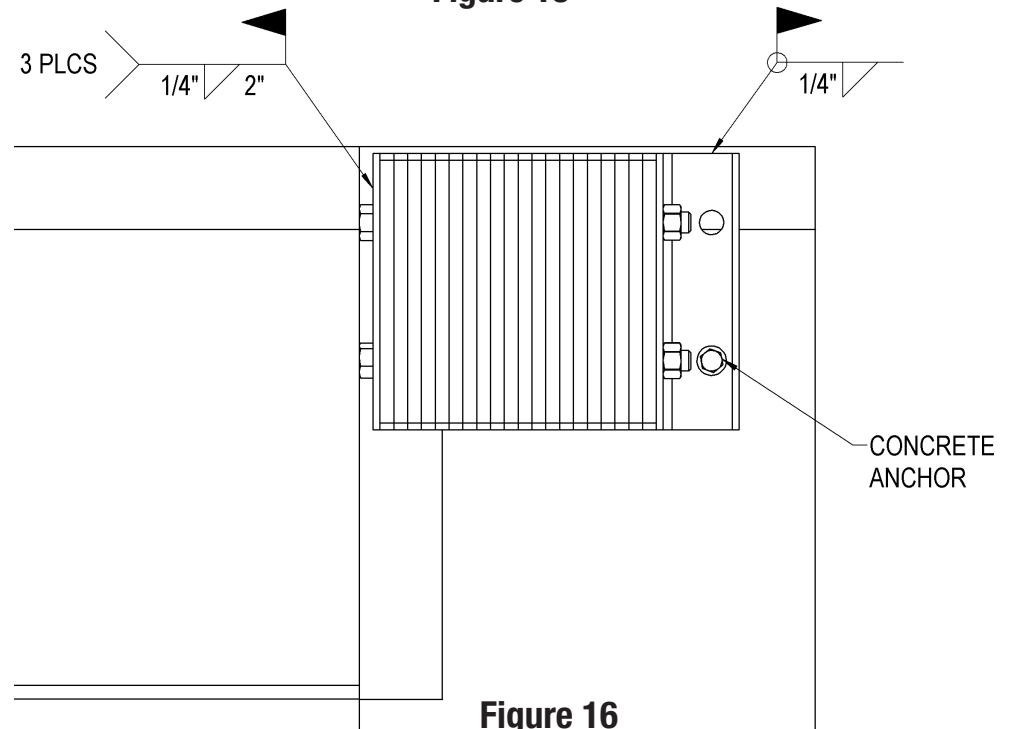

Figure 16

INSTALLATION INSTRUCTIONS CONTINUED...

3. Remove the four deck transportation loops, as shown in **Figure 17**.
4. Locate the eight deck plugs in the hardware bag. Insert them in the four holes where the deck transportation loops were bolted and the four holes for accessing the rear leveling bolts, as shown in **Figure 18**.
5. Be sure all tools and debris are removed from the leveler and the surrounding area.

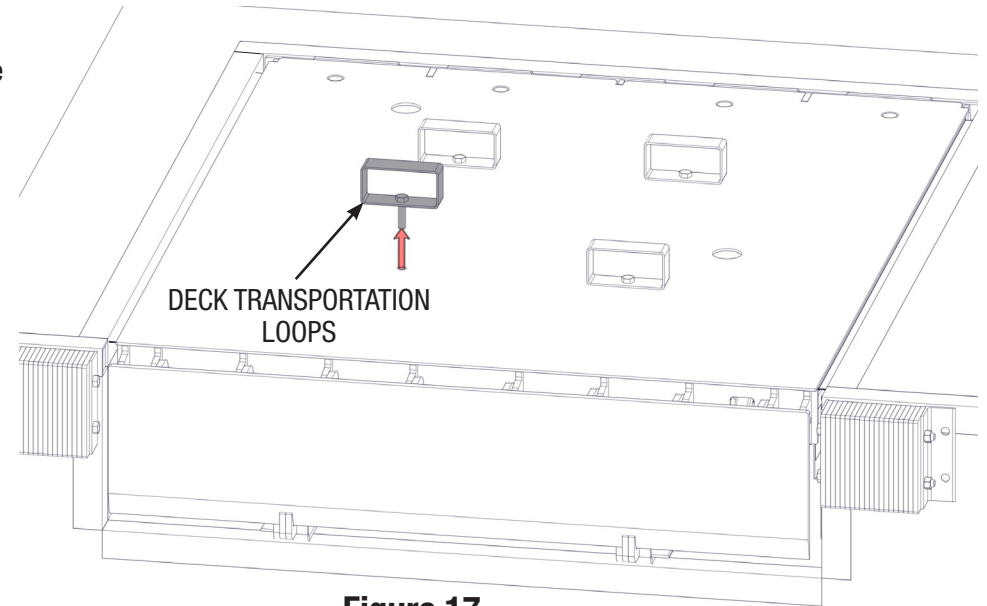

Figure 17

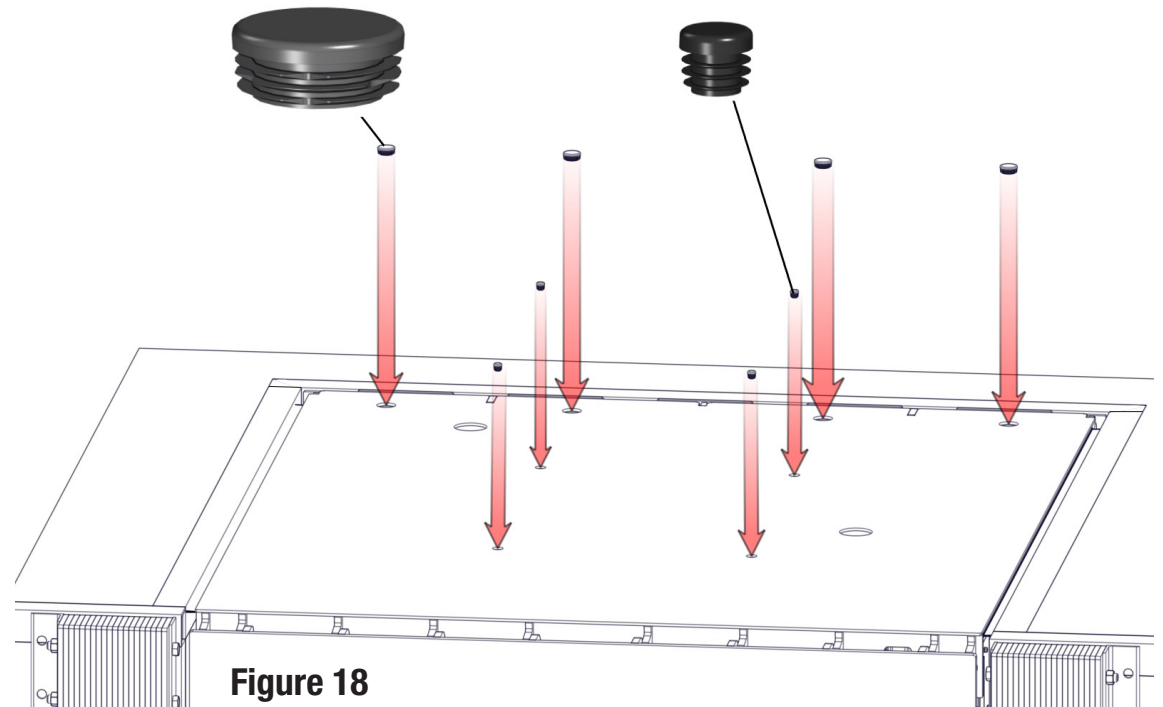

Figure 18

INSTALLATION INSTRUCTIONS CONTINUED...

INSTALL OPERATION PLACARD

1. Install operation placard on the wall near the opening in plain view of the dock leveler with an appropriate adhesive or fasteners. See **Figure 19**.



|  DANGER | OPERATING INSTRUCTIONS |
|--|---|
| <ul style="list-style-type: none"> • Read and follow all instructions, warnings and maintenance schedules in the manual. • Operation and servicing of dock leveler is restricted to authorized personnel. • Always chock trailer wheels or engage trailer restraint before operating dock leveler or beginning to load or unload. • Never use hands or equipment to move ramp or lip. • Before activating dock leveler: <ul style="list-style-type: none"> • Ensure trailer is backed up against bumpers. • Remove any end load, if required. • Check trailer alignment to avoid lip interference. If lip does not lower to trailer bed, reposition vehicle. • Ensure truck bed supports extended lip or leveler frame supports the ramp before driving on ramp. • Stay clear of hinges and front and sides of moving dock leveler. • Never use damaged or malfunctioning dock leveler. Report problems immediately to supervisor. • Before allowing vehicle to leave the dock always: <ul style="list-style-type: none"> • Ensure no equipment, material or people are on dock leveler. • Return dock leveler to its stored position at dock level. • DO NOT ENTER THE PIT unless dock leveler is securely supported by maintenance strut. <p>FAILURE TO FOLLOW THESE INSTRUCTIONS WILL RESULT IN DEATH OR SERIOUS INJURY.</p> <p><small>If you need assistance, scan the QR Code, or contact your local Wayne Dalton Dealer. To find your local Wayne Dalton Dealer, go online to www.Wayne-Dalton.com.</small></p>  | <div style="background-color: black; color: white; text-align: center; padding: 5px;">Mechanical Pit Levelers</div> <div style="background-color: #e0e0e0; padding: 5px;">EXTENDING THE LEVELER ONTO BED OF TRANSPORT VEHICLE</div> <ol style="list-style-type: none"> 1. Standing on the warehouse floor, grasp the ring connected to the release chain and pull, holding the ring and chain taut while the platform reaches the fully raised position. Release the ring. 2. Carefully, walk out onto the platform of dock leveler. This will allow the dock to lower, resting its lip onto the transport vehicle. <div style="background-color: #e0e0e0; padding: 5px;">RETURNING LEVELER TO STOWED POSITION</div> <ol style="list-style-type: none"> 1. Grasp the ring connected to the release chain and pull, holding the ring and chain taut while the platform reaches the fully raised position. Release the ring. 2. Slowly walk the platform down, allowing the lip to fold down and clear the transport vehicle. Continue to walk toward the end of the platform, until the lip is resting inside the lip keepers and the platform is parallel with the warehouse floor. <div style="background-color: #e0e0e0; padding: 5px;">BELOW DOCK ENDLOADING</div> <ol style="list-style-type: none"> 1. Standing on the warehouse floor, grasp the ring connected to the release chain and pull, holding the ring and chain taut while the platform reaches the fully raised position. Release the ring. 2. Walk onto the platform, not allowing the lip to fold down. Pull and hold the safety leg pull chain ring taut, located towards the front of the dock leveler, as the leveler continues to descend into the below-dock position. Release the safety leg pull chain ring, when the dock leveler is resting on the transport vehicle. |

Figure 19

TESTING AND SPRING ADJUSTMENTS

⚠ DANGER

DOCK LEVELER SWINGS WITH CONSIDERABLE FORCE. ACTUATING THE DOCK LEVELING DEVICE WITH ANYONE UNDER OR IN FRONT OF IT WILL CAUSE DEATH OR SERIOUS INJURY.

⚠ DANGER

KEEP HANDS, FEET AND OTHER APPENDAGES CLEAR OF HINGES AND OTHER PINCH POINTS WHEN MOVING, INSTALLING, OPERATING, SERVICING, OR OTHERWISE MANIPULATING THE DOCK LEVELING DEVICE. THIS DEVICE IS HEAVY AND MOVES WITH CONSIDERABLE FORCE, CAPABLE OF SEVERING APPENDAGES AND CAUSING SERIOUS INJURY OR DEATH.

⚠ DANGER

DO NOT WORK UNDER DOCK LEVELER UNLESS MAINTENANCE BRACE HAS BEEN SECURED IN THE UPRIGHT POSITION. FAILURE TO COMPLY WILL RESULT IN DEATH OR SERIOUS INJURY.

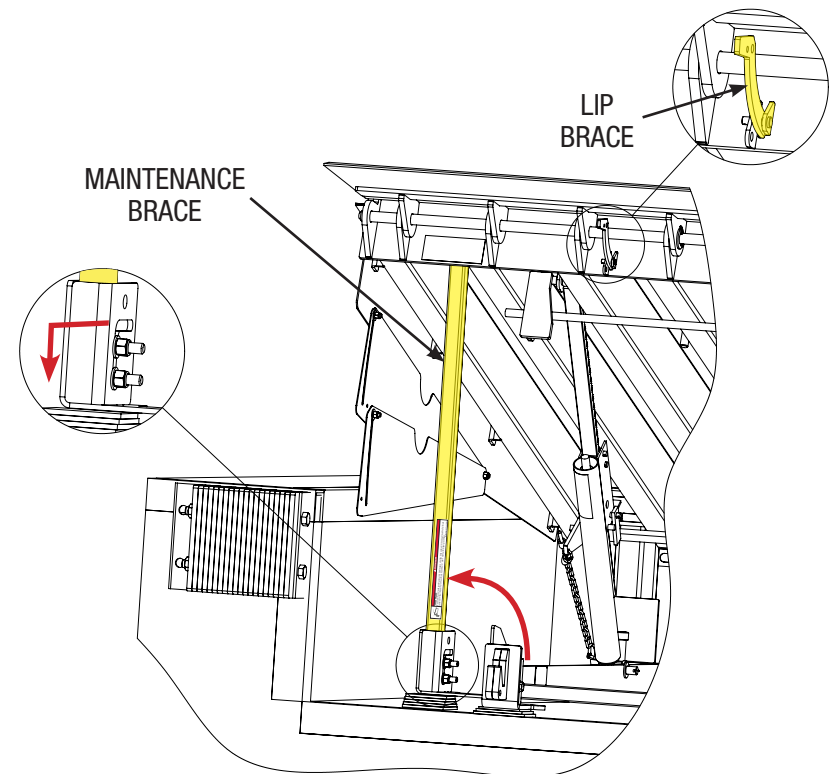

Figure 20

TESTING AND SPRING ADJUSTMENTS CONTINUED...

DANGER

THE ADJUSTMENT OF PIT LEVELER SPRINGS SHALL BE PERFORMED BY TRAINED DOCK SYSTEM TECHNICIANS ONLY. DO NOT ATTEMPT TO REMOVE SPRINGS UNTIL THE TENSION IS COMPLETELY AND PROPERLY REMOVED. SPRINGS CAN UNEXPECTEDLY RELEASE HIGH POTENTIAL ENERGY WHICH COULD CAUSE DEATH OR SERIOUS INJURY.

WARNING

PRIOR TO SERVICING, ALWAYS BARRICADE OR PLACE TRAFFIC CONES ON ALL SIDES OF THE LEVELER TO ALERT FORK VEHICLE OPERATORS AND PEDESTRIANS THAT A SERVICE TECHNICIAN MAY BE WORKING BELOW THE DOCK. NOTIFY A SUPERVISOR/FOREMAN PRIOR TO BEGINNING WORK. COMPLY WITH ALL OSHA STANDARDS AND REGULATIONS.

DANGER

SECURELY SUPPORT RAMP AND LIP WHILE WORKING BELOW THE LEVELER PLATFORM. FAILURE TO USE PROPER BRACING WILL RESULT IN DEATH OR SERIOUS INJURY DUE TO RAMP DROPPING. A SECONDARY MEANS OF SUPPORTING THE RAMP AND LIP SHOULD BE USED. FAILURE TO FOLLOW THESE PRECAUTIONS MAY RESULT IN DEATH OR SERIOUS INJURY.

WARNING

APPROPRIATE PERSONAL PROTECTIVE EQUIPMENT (PPE) SHOULD ALWAYS BE USED. THIS INCLUDES BUT IS NOT LIMITED TO A HARD HAT WHEN WORKING BELOW LEVELER DECK, APPROPRIATE EYE PROTECTION, GLOVES, AND HARD-CAPPED SLIP-RESISTANT FOOTWEAR WHEN WORKING ON OR NEAR THE DOCK AREA.

After the mechanical pit leveler is welded in place, the springs should be adjusted to ensure optimal functionality. The following procedure is designed to minimize the time required to achieve the ideal spring settings.

1. Cycle the unit a few times to check operations and functions of the unit.
2. Raise the deck and lip to their highest position and engage the deck and lip maintenance braces. Verify all hinge and pivot points are properly lubricated per the Preventative Maintenance section.
3. Disengage and stow both maintenance braces.
4. Bring the unit to six (6) inches above dock level. Extend the lip fully. Time the lip as it falls to pendant position. The fall time should be between 12 to 18 seconds. If the time is achieved go to STEP 6. If not continue to next step.

TESTING AND SPRING ADJUSTMENTS CONTINUED...

5. Brace the deck in its uppermost position and adjust the lip actuation spring: loosen up the jam-nut and firmly grasp the square adjustment tube by hand or with a wrench and turn the lip spring adjustment bolt (see **Figure 21**). Clockwise to tighten, counterclockwise to remove tension. Tighten the jam-nut once proper setting is achieved. Retest STEP 4.
6. Once the lip is properly adjusted, adjust the main spring tension so that the lip fully extends when pulling the hold down release chain from the leveler stowed position. The lip should have a “snap” to it when the unit fully opens. This will require several attempts, alternating between adjusting the main spring tension and checking if the lip is deploying, and is more easily achieved with two people.
 - a) To adjust the main spring tension, loosen up the jam-nut and turn the adjustment nut on the scissor mechanism as shown in **Figure 22**. Clockwise to tighten, counterclockwise to remove tension. Tighten the jam-nut once proper setting is achieved.

⚠ DANGER

ENSURE THE SPRINGS ARE NOT OVERTIGHTENED. ATTEMPTING TO FORCE THE LEVELER DOWN WHEN SPRINGS ARE OVERTIGHTENED COULD CAUSE THE SPRINGS TO BREAK, CAUSING UNCONTROLLED RAPID DESCENT. FAILURE TO ENSURE PROPER SPRING ADJUSTMENT WILL RESULT IN DEATH OR SERIOUS INJURY.

⚠ DANGER

ENSURE THE SPRINGS ARE NOT UNDERTIGHTENED. DECK COULD DROP UNCONTROLLABLY WITH INSUFFICIENT SPRING TENSION. ENSURE THE UNDERSIDE OF THE LEVELER DECK IS NOT CONTACTING THE MAINTENANCE BRACE BEFORE REMOVING BRACING. REMOVING THE BRACING WHEN IT IS CONTACTING THE UNDERSIDE OF THE DECK WILL RESULT IN DEATH OR SERIOUS INJURY.

IMPORTANT: Excessive tension on the main springs will make the leveler difficult to walk down. Too little tension may prevent the lip from deploying properly. A quarter turn of the adjustment nut can make a substantial difference.

NOTE: Spring adjustment may be required with new springs due to potential spring settling.

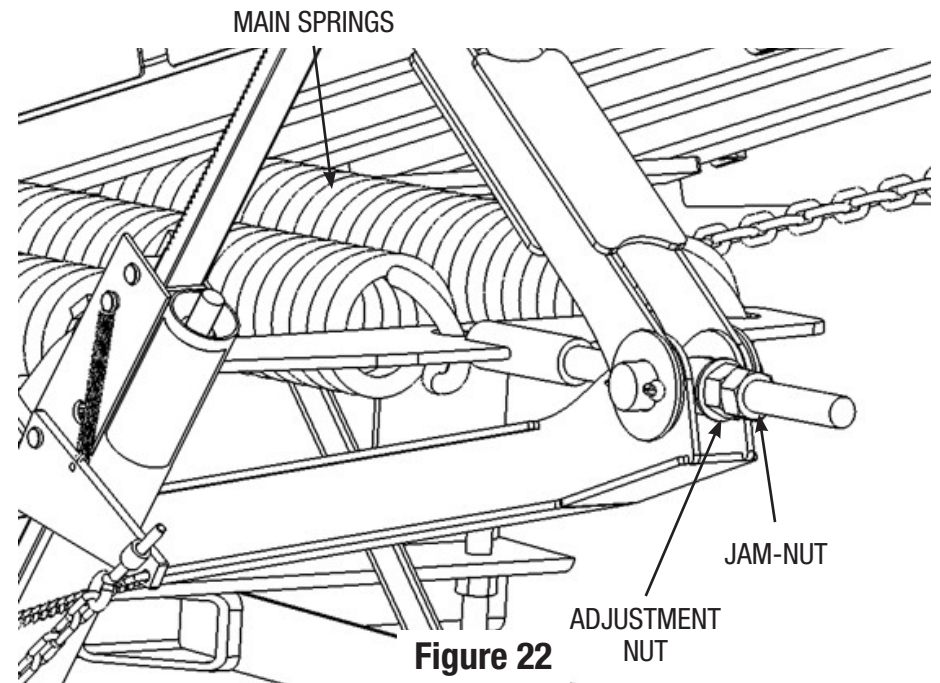
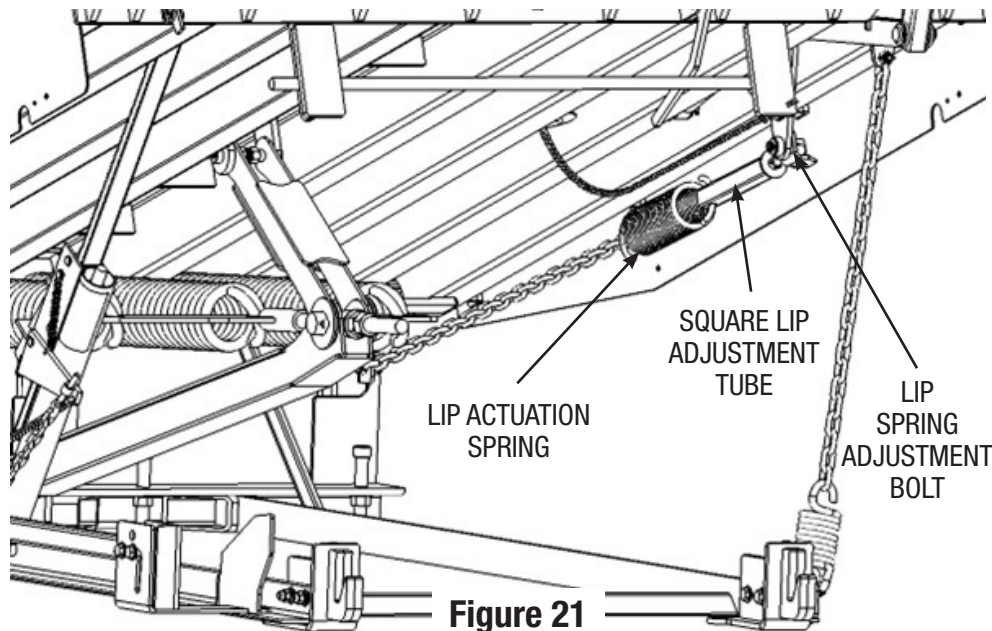

TROUBLESHOOTING



PIT LEVELER INSPECTION AND TROUBLESHOOTING SHALL BE PERFORMED BY TRAINED DOCK SYSTEM TECHNICIANS ONLY.

TROUBLESHOOTING: SYMPTOMS, CAUSES AND SOLUTIONS

| SYMPTOM | POTENTIAL CAUSE | SOLUTION |
|--|---|--|
| Dock leveler rubs vertical pit walls | Pit is not square | Use vertical shims along the rear curb angle to square off the rear pit wall |
| | Leveler not welded flush to rear curb angle | Remove leveler, clean rear curb angle from slag/debris, verify squareness of pit, then reinstall leveler |
| | Toe guard loose | Fasten toe guards securely |
| | Pit too small for leveler | Contact factory |
| Dock leveler deck does not rise properly | Shipping bands not removed | Remove shipping materials |
| | Weight on deck surface | Remove weight from deck. Do not stand on deck when pulling hold down release chain |
| | Debris in rear hinge | Clean out rear hinge using broom and/or compressed air |
| | Dock leveler obstructed by pit walls | Refer to symptom, "Dock leveler rubs vertical pit walls" |
| | Transport vehicle obstructs pit leveler | Move transport vehicle. Check bumpers for excessive wear. If bumpers are not worn, consult factory |
| | Snubber chain snagged | Unsnag snubber chain from obstruction, including the snubber spring |
| | Main spring(s) is/are broken or worn | Replace damaged spring(s) |
| | Springs have too little tension | Adjust springs per Mechanical Pit Leveler Adjustments section |
| | Scissor mechanism seized/broken | Lubricate per Periodic Maintenance, repair and/or replace scissor mechanism, as needed |
| | Rear hinge seized | Lubricate rear hinge shaft per Periodic Maintenance |
| | Hold down chain stuck/broken | Unsnag hold down chain or replace, as needed |
| | Hold down pawl stuck | Lubricate pawl pins or replace, as needed. DO NOT LUBRICATE RATCHET TEETH |
| | Snubber chain is too short | Verify snubber chain length per replacement part table and replace if needed |
| Deck is obstructed | Remove all foreign obstructions | |

TROUBLESHOOTING CONTINUED...

| TROUBLESHOOTING: SYMPTOMS, CAUSES AND SOLUTIONS | | |
|---|---|---|
| SYMPTOM | POTENTIAL CAUSE | SOLUTION |
| Deck does not stow properly | Debris in rear hinge | Clean out rear hinge using broom and/or compressed air |
| | Maintenance brace is deployed | Stow maintenance brace |
| | Main springs have too much tension | Adjust springs per Mechanical Pit Leveler Adjustments section |
| | Obstruction under deck | Remove all foreign obstructions from below deck |
| | Scissor mechanism seized/broken | Lubricate per Periodic Maintenance, repair and/or replace scissor mechanism, as needed |
| | Lip keepers are out of place, missing, or damaged | Verify lip keepers are and welded in the correctly position |
| | Hold down is broken/seized | Replace hold down |
| Lip does not deploy or drop properly | Springs improperly set | Adjust springs per Mechanical Pit Leveler Adjustments section |
| | Lip actuation linkage is corroded or seized | Lubricate, repair, and replace as needed |
| | Lip damper damaged/broken | Remove damper and ensure it can be compressed manually. Replace damper if it does not compress manually |
| | Transport vehicle obstructs pit leveler lip | Move transport vehicle. Check bumpers for excessive wear. If bumpers are not worn, consult factory |
| | Lip is damaged/bowed | Consult factory |
| | lip hinge shafts are worn through or seized | Replace shafts, as needed |
| | Lip spring is damaged or broken | Replace lip spring |
| | Lip actuation chain is snagged | Ensure lip chain is not caught |
| | Lip actuation chain | Verify lip actuation chain length per replacement part table and fix/replace, as needed |
| | Lip maintenance brace is deployed | Stow lip maintenance brace |
| | Lip actuation linkage is bent/damaged | Replace linkage parts, as needed |

TROUBLESHOOTING CONTINUED...

| TROUBLESHOOTING: SYMPTOMS, CAUSES AND SOLUTIONS | | |
|---|---|---|
| SYMPTOM | POTENTIAL CAUSE | SOLUTION |
| Safety legs not retracting/deploying | Safety leg chain is snagged/broken | Free safety leg chain or replace as needed |
| | Safety leg spring is broken | Replace safety leg spring |
| | Safety leg parts missing or broken | Replace/repair, as needed |
| | Lip keepers set incorrectly | Ensure lip keepers are aligned below safety legs |
| Weld to rear curb angle is broken/cracked | Leveling bolts are not contacting the pit floor | Extend all leveling bolts per installation instructions. Repair weld |
| Leveler is broken/cracked | Load exceeded manufacturer factored load limit | Document with installer and repair/replace per manufacturer instruction |
| | Driving too fast over leveler | |
| Painted areas flaking/wearing | Harsh chemicals used | Clean surface and reapply touchup paint |
| | Too thin of a touchup paint coat applied | |
| | Dirty surface prior to field paint | |
| Chipped or cracked powder coating | Bent or broken equipment | Inspect and replace/touch up, as needed |
| Lip does not clear transport vehicle | Bumpers are worn | Replace worn bumpers |
| | Drive grade is incompatible with bumper projection and lip length | Replace with compatible bumper projection |
| Pallet jack or loading vehicle scrapes against leveler platform | Pallet jack is too low | Raise pallet jack to max height |
| | Transport vehicle is too high or dock is too low | Consult factory |

MAINTENANCE

DANGER

READ THESE INSTRUCTIONS CAREFULLY BEFORE ATTEMPTING MAINTENANCE. IF YOU ARE IN QUESTION ABOUT ANY OF THE PROCEDURES, DO NOT PERFORM THE WORK. REPAIRS SHOULD ONLY BE PERFORMED BY A TRAINED DOCK LEVELER SYSTEMS TECHNICIAN. FAILURE TO FOLLOW SAFETY INSTRUCTIONS WILL RESULT IN DEATH OR SERIOUS INJURY.

DANGER

DO NOT WORK UNDER DOCK LEVELER UNLESS MAINTENANCE BRACE HAS BEEN SECURED IN THE RAISED SERVICE POSITION. SECURELY SUPPORT RAMP AND LIP WITH MAINTENANCE BRACES WHEN RAMP IS IN RAISED SERVICE POSITION. A SECONDARY MEANS OF SUPPORTING THE RAMP AND LIP SHOULD BE USED. FAILURE TO USE PROPER BRACING WILL RESULT IN DEATH OR SERIOUS INJURY.

DANGER

NEVER ATTEMPT TO ADJUST THE ENCLOSED COMPRESSION SPRING IN THE HOLD DOWN MECHANISM. THIS SPRINGS CAN UNEXPECTEDLY RELEASE HIGH POTENTIAL ENERGY WHICH COULD CAUSE DEATH OR SERIOUS INJURY.

DANGER

PRIOR TO SERVICING, ALWAYS BARRICADE OR PLACE TRAFFIC CONES ON ALL SIDES OF THE LEVELER TO ALERT FORK VEHICLE OPERATORS AND PEDESTRIANS THAT A SERVICE TECHNICIAN MAY BE WORKING BELOW THE DOCK. NOTIFY A SUPERVISOR/FOREMAN PRIOR TO BEGINNING WORK. COMPLY WITH ALL OSHA STANDARDS AND REGULATIONS.

WARNING

APPROPRIATE PERSONAL PROTECTIVE EQUIPMENT (PPE) SHOULD ALWAYS BE USED. THIS INCLUDES BUT IS NOT LIMITED TO: A HARD HAT WHEN WORKING BELOW LEVELER DECK, EYE PROTECTION, GLOVES, AND HARD-CAPPED SLIP-RESISTANT FOOTWEAR WHEN WORKING ON OR NEAR THE DOCK AREA. FAILURE TO USE APPROPRIATE PPE COULD RESULT IN SEVERE OR FATAL INJURY.

Before starting repair or inspection of a dock leveler device:

- a) Secure and restrict access in and around the dock position (dock and driveway) with physical barriers and visible signage.
- b) Read, understand, and follow all maintenance instructions and precautions provided.
- c) Remove all loads from the platform; and
- d) Disconnect power and follow established OSHA-approved lockout / tag-out policies as required.

Maintenance and inspection of all dock leveling devices shall be performed in conformance with the following practices:

- a) Scheduled, planned maintenance program shall be followed and logged.
- b) Only trained and authorized personnel shall be permitted to maintain, repair, adjust, and inspect dock leveling devices.
- c) Use only original equipment manufacturer parts, manuals, maintenance instructions and labels.

MAINTENANCE CONTINUED...

Daily Maintenance

At the beginning of each shift and before operation of the dock leveling device, the operator shall inspect the condition of the dock leveling device, giving special attention to the following:

1. Ensure hinges and surfaces are free of debris, ice, dirt, or obstruction.
2. Verify all precautionary labeling and operation placards are intact, visible, and legible.
3. If leveler has guards or safety devices, ensure they are present and functional.
4. Perform a function check to ensure controls are fully operational.
5. Inspect that unit is free of visible structural defect or damage.

Weekly Maintenance

1. Cycle the dock leveler through at least one complete operating cycle to maintain lubrication.
 - a) Observe for imbalance. If leveler is sluggish, heavy or binds, the lip does not deploy with a snap, or cannot be walked down, call authorized, trained personnel to adjust the springs and inspect the unit.
2. Check bumpers for wear. If the leveler begins to interfere with the transport vehicle during deployment or stowing, it is time to replace the bumpers.
3. Clean dock leveler with warm soapy water.

NOTE: Sodium hydroxide cleaning solution may be used if it is diluted to <5% and completely rinsed clean within 3 minutes. Ensure lubrication is not washed off.

Quarterly Maintenance

1. Lubricate the following areas with calcium sulfonate complex grease or other long-lasting, weather & pressure resistant, anti-seize, penetrating, lubricating oil/grease. See **Figure 23**:

- | | |
|-------------------------------------|--------------------------------|
| a) All lip actuation linkage joints | b) Lug hinge contact surfaces. |
| c) Scissor mechanism pins. | d) Rear hinge shaft |

NOTICE

NEVER LUBRICATE THE RATCHET OR PAWL TEETH ON THE HOLD DOWN SYSTEM. THE FLAT BACKSIDE OF THE RATCHET BAR MAY BE LUBRICATED WITH A NON-RUNNING GREASE.

2. Clean out rear hinge with broom or compressed air.
3. Inspect welds and structure for cracks, separation or other damage. Repair field welds and replace damaged components, as appropriate.
 - a) Inspect welds between the leveler and the rear pit curb angle.
 - b) Inspect structural welds below leveler lip.
 - c) Inspect welds of bumpers to dock structure.
 - d) Inspect hinge and pivot pins for wear.
4. Perform Weekly Maintenance
5. Tune the spring for easy, smooth operation
6. Check wall anchors/anchor nuts for tightness.

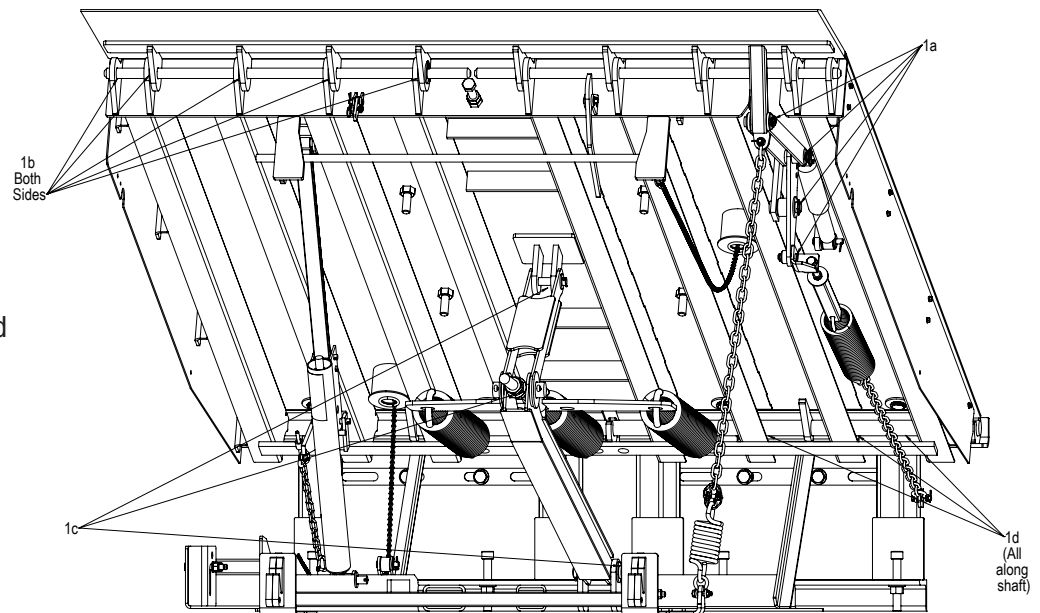

Figure 23

MAINTENANCE CONTINUED...

LOCKOUT/TAGOUT

Occupational Safety and Health Administration (OSHA) rules and regulations require all affected employees be notified when equipment is shut down/locked out for repair and/or maintenance work.

- a) Utilize OSHA-approved lockout devices.
- b) The tagout tags indicating that work is being done on equipment should be prominently visible and clearly bear the name of the authorized person responsible for the lockout.
- c) Tagout notices shall not be susceptible to deterioration or become illegible due to environmental conditions or chemical exposure.
- d) Always follow local, state, and federal codes.
- e) Always lockout and tagout power sources prior to beginning work on electrical devices/controls.

CONFINED SPACE

If a confined space entry associated with operations or maintenance of a dock leveling device is required, the confined space procedures shall comply with ANSI/ASSP Z117.1.

REPLACEMENT PARTS

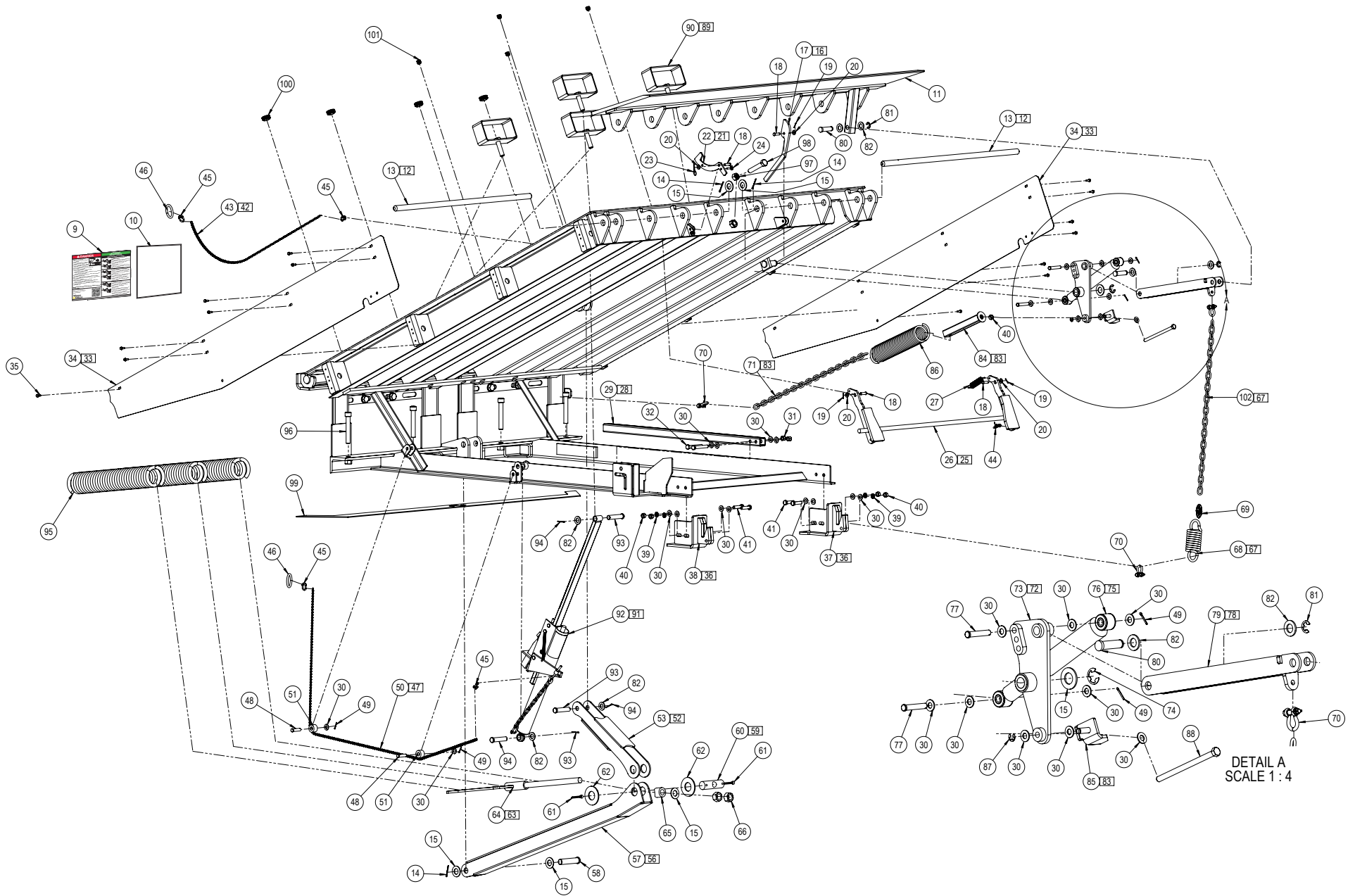

Figure 24

REPLACEMENT PARTS CONTINUED...

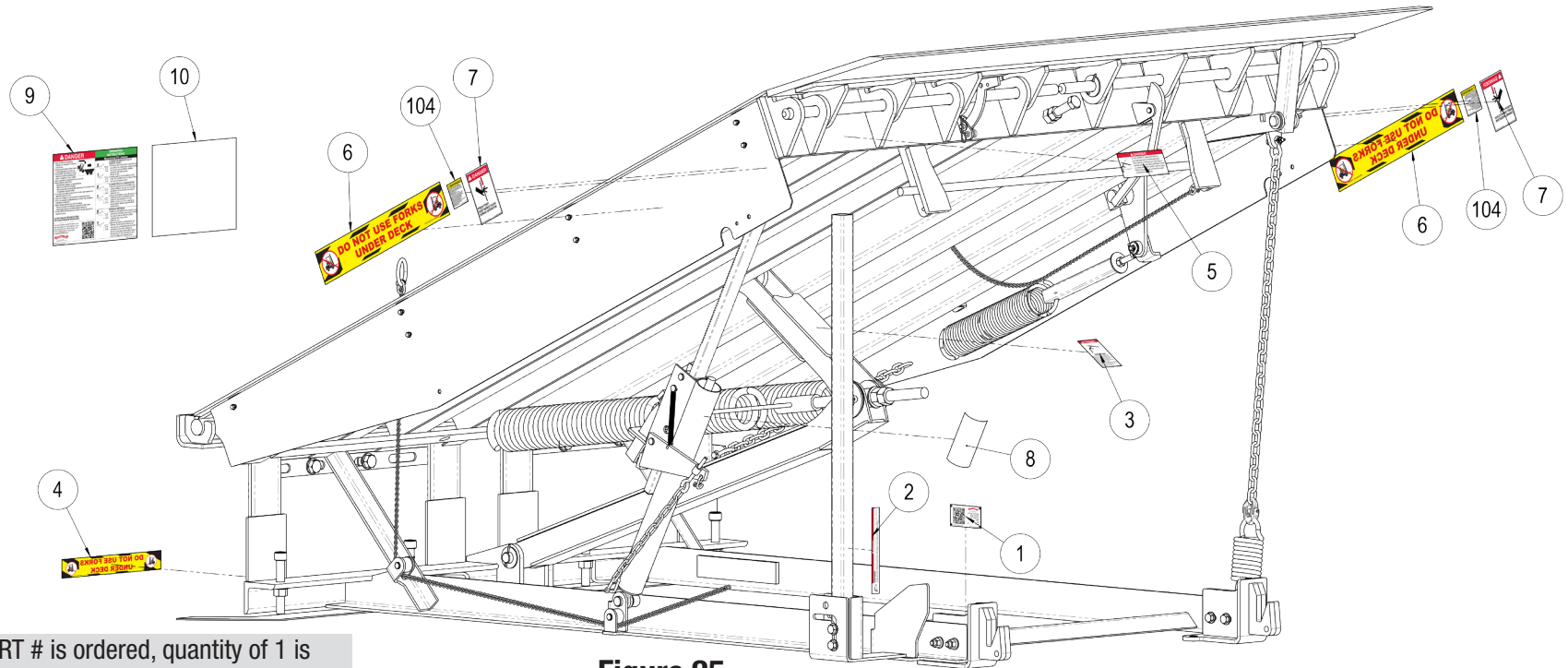

Figure 25

NOTE: * When PART # is ordered, quantity of 1 is shipped (not the QTY PER LEVELER).

SERVICE PARTS LISTS

| ITEM # | MODEL # | CAPACITY (CIR) (POUNDS) | LIP SIZE (INCHES) | PART # | PART DESCRIPTION | QTY PER LEVELER |
|--------|------------------|----------------------------|----------------------|--------------|--|-----------------|
| 1 | M68WD / M78WD | ALL | ALL | 851054.0001 | SERIAL# & MODEL TAG | 1 |
| 2 | | | | 852402.0001 | LABEL, CRUSH HAZARD, STRUT, MPL | 1 |
| 3 | | | | 852403.0001 | LABEL, CRUSH HAZARD, SPRING, MPL | 1 |
| 4 | | | | 852404.0001 | LABEL, CAUTION, FORKS, DO NOT USE, MPL | 1 |
| 5 | | | | 852405.0001 | LABEL, CRUSH HAZARD, PIT, MPL | 1 |
| 6 | | | | 852420.0001* | LABEL, CAUTION, FORKS, DO NOT USE, LG, MPL | 2 |
| 7 | | | | 852421.0001* | LABEL, DANGER, PINCH POINT, MPL | 2 |
| 8 | | | | 852406.0001 | LABEL, SPRING, STORED ENERGY, MPL | 1 |
| 9 | | | | 852400.0001 | OPERATING INSTRUCTIONS AND DANGER PLACARD, MPL | 1 |
| 10 | | | | 852410 | MANUAL, OPERATION AND INSTALLATION | 1 |
| 104 | 361553* | LABEL, PROP65 | 2 | | | |

REPLACEMENT PARTS CONTINUED...

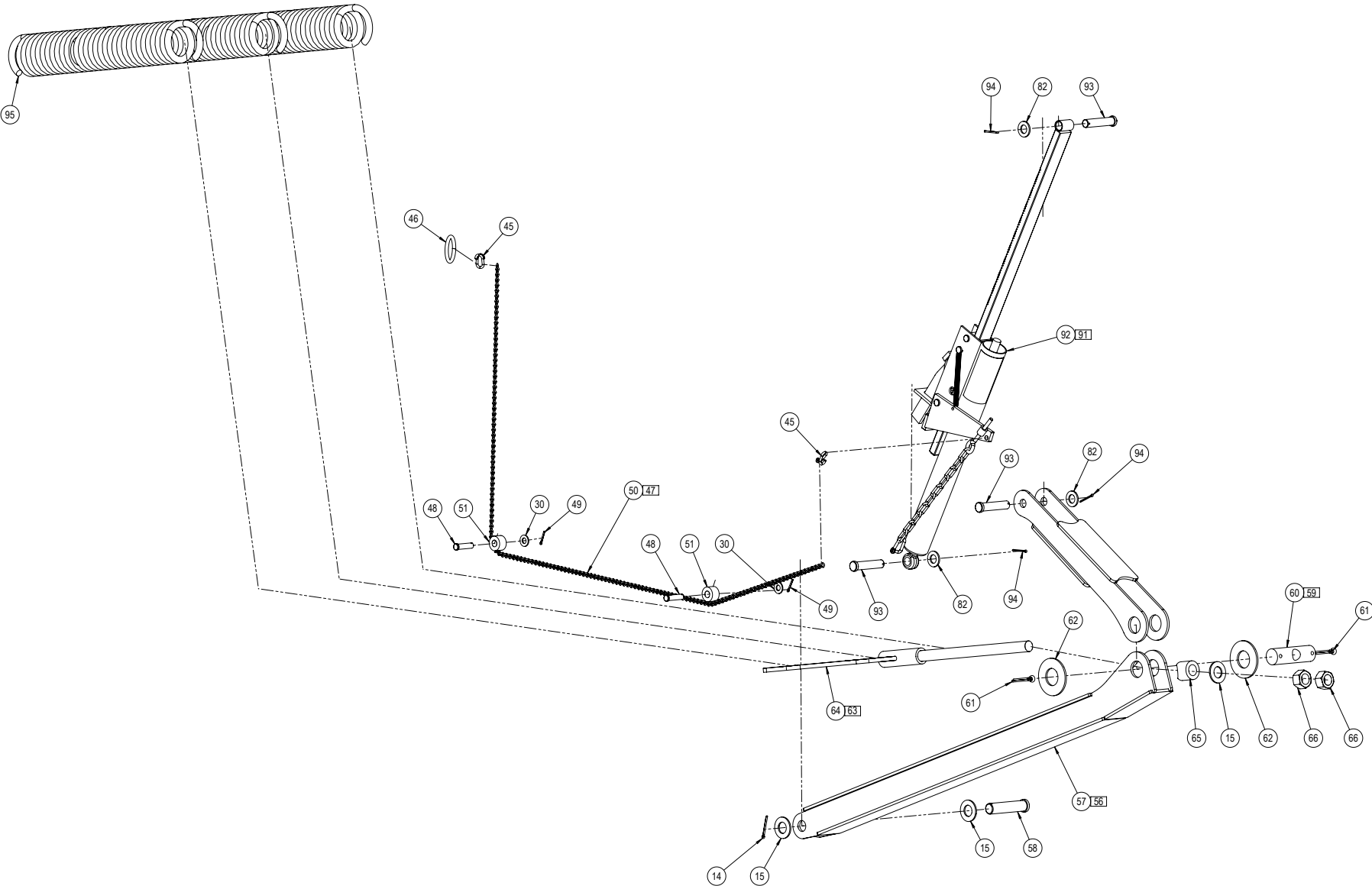

Figure 26

REPLACEMENT PARTS CONTINUED...

| SERVICE PARTS LISTS | | | | | | |
|---------------------|---------|----------------------------|----------------------|-------------|---|-----------------|
| ITEM # | MODEL # | CAPACITY (CIR) (POUNDS) | LIP SIZE (INCHES) | PART # | PART DESCRIPTION | QTY PER LEVELER |
| 47 | ALL | ALL | ALL | 852500.0011 | REPLACEMENT HOLD DOWN PULL CHAIN W/ HARDWARE KIT | |
| 48 | | | | | PIN, CLEVIS, PLATED | 2 |
| 49 | | | | | PIN, COTTER, PLATED | 2 |
| 30 | | | | | FLAT WASHER, PLATED | 2 |
| 50 | | | | | CHAIN, TWISTED LINK | 1 |
| 45 | | | | | LINK, BEND-CLOSE | 2 |
| 46 | | | | | RING, STAINLESS | 1 |
| 51 | | | | | ROLLER, PLASTIC | 2 |
| 52 | ALL | ALL | ALL | 852500.0012 | REPLACEMENT UPPER SCISSOR LINKAGE W/ HARDWARE KIT | |
| 53 | | | | | UPPER SCISSOR ARM | 1 |
| 93 | | | | | PIN, CLEVIS, PLATED | 1 |
| 94 | | | | | PIN, COTTER, PLATED | 1 |
| 82 | | | | | FLAT WASHER, PLATED | 1 |
| 3 | | | | | LABEL, CRUSH HAZARD, SPRING, MPL | 1 |
| 56 | ALL | ALL | ALL | 852500.0013 | REPLACEMENT LOWER SCISSOR LINKAGE W/ HARDWARE KIT | |
| 57 | | | | | LOWER SCISSOR ARM | 1 |
| 58 | | | | | PIN, CLEVIS, PLATED | 1 |
| 14 | | | | | PIN, COTTER, PLATED | 1 |
| 15 | | | | | FLAT WASHER, PLATED | 2 |
| 59 | ALL | ALL | ALL | 852500.0014 | REPLACEMENT SCISSOR LINKAGE CONNECTING PIN W/ HARDWARE KIT | |
| 60 | | | | | PIN, PIVOT, PLATED | 1 |
| 61 | | | | | PIN, COTTER, PLATED | 2 |
| 62 | | | | | FLAT WASHER, PLATED | 2 |

REPLACEMENT PARTS CONTINUED...

| SERVICE PARTS LISTS | | | | | | |
|---------------------|---------|----------------------------|----------------------|--------------|--|-----------------|
| ITEM # | MODEL # | CAPACITY (CIR) (POUNDS) | LIP SIZE (INCHES) | PART # | PART DESCRIPTION | QTY PER LEVELER |
| 63 | ALL | ALL | ALL | 852500.0015 | REPLACEMENT WINGPLATE W/ HARDWARE KIT | |
| 64 | | | | | WING, SPRING ADJUSTMENT | 1 |
| 65 | | | | | SPACER, SADDLE, PLATED | 1 |
| 15 | | | | | FLAT WASHER, PLATED | 1 |
| 66 | | | | | NUT, HEX, PLATED | 2 |
| 91 | ALL | ALL | ALL | 852500.0022 | HOLD DOWN W/ HARDWARE KIT | |
| 92 | | | | | HOLD DOWN ASSEMBLY, AUTO-RELEASE | 1 |
| 93 | | | | | PIN, CLEVIS, PLATED | 2 |
| 94 | | | | | PIN, COTTER, PLATED | 2 |
| 82 | | | | | FLAT WASHER, PLATED | 2 |
| 95 | M68WD | 30K / 35K | ALL | 852264.0001* | SPRING, MAIN ACTUATION,RED | 3 |
| | | 40K / 45K | | 852264.0001* | SPRING, MAIN ACTUATION,RED | 2 |
| | | | | 852265.0001* | SPRING, MAIN ACTUATION,YELLOW | 2 |
| | M78WD | 30K / 35K | | 852264.0001* | SPRING, MAIN ACTUATION,RED | 2 |
| | | | | 852265.0001* | SPRING, MAIN ACTUATION,YELLOW | 2 |
| | | 40K / 45K | | 852264.0001* | SPRING, MAIN ACTUATION,RED | 4 |

NOTE: * When PART # is ordered, quantity of 1 is shipped (not the QTY PER LEVELER).

REPLACEMENT PARTS CONTINUED...

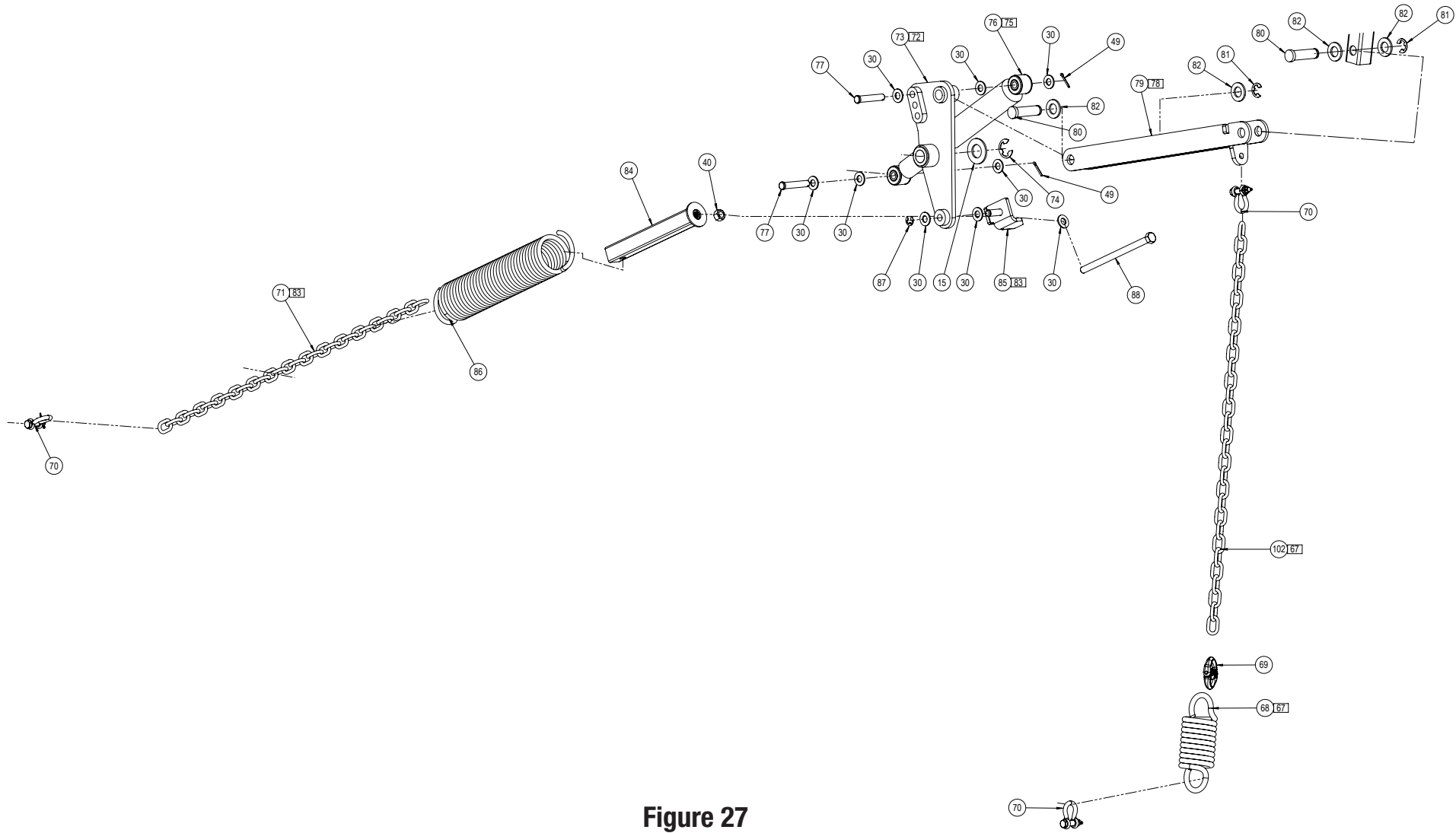

Figure 27

REPLACEMENT PARTS CONTINUED...

SERVICE PARTS LISTS

| ITEM # | MODEL # | CAPACITY (CIR) (POUNDS) | LIP SIZE (INCHES) | PART # | PART DESCRIPTION | QTY PER LEVELER |
|-----------|---------|----------------------------|----------------------|-------------|--|-----------------|
| 67 | ALL | ALL | ALL | 852500.0016 | REPLACEMENT SNUBBER CHAIN & SPRING W/ HARDWARE KIT | |
| 68 | | | | | SPRING, SNUBBER | 1 |
| 69 | | | | | LINK, HAMMER | 1 |
| 70 | | | | | SHACKLE, GALV | 2 |
| 102 | | | | | CHAIN, SNUBBER, PLATED, .25IN THICK | 1 |
| 72 | ALL | ALL | ALL | 852500.0017 | REPLACEMENT LIP ACTUATION PIVOT W/ HARDWARE KIT | |
| 73 | | | | | PIVOT, LIP ACTUATION | 1 |
| 74 | | | | | RING, RETAINING | 1 |
| 15 | | | | | FLAT WASHER, PLATED | 1 |
| 75 | ALL | ALL | ALL | 852500.0018 | REPLACEMENT LIP ACTUATION DAMPER W/ HARDWARE KIT | |
| 76 | | | | | DAMPER, HYDRAULIC | 1 |
| 77 | | | | | PIN, CLEVIS, PLATED | 2 |
| 49 | | | | | PIN, COTTER, PLATED | 2 |
| 30 | | | | | FLAT WASHER, PLATED | 6 |
| 78 | ALL | ALL | ALL | 852500.0019 | REPLACEMENT LIP ACTUATION PIVOT LINKAGE W/ HARDWARE KIT | |
| 79 | | | | | LINK, LIP ACTUATION | 1 |
| 80 | | | | | PIN, CLEVIS, PLATED | 2 |
| 81 | | | | | RING, RETAINING | 2 |
| 82 | | | | | FLAT WASHER, PLATED | 4 |

REPLACEMENT PARTS CONTINUED...

SERVICE PARTS LISTS

| ITEM # | MODEL # | CAPACITY (CIR) (POUNDS) | LIP SIZE (INCHES) | PART # | PART DESCRIPTION | QTY PER LEVELER |
|--------|---------|----------------------------|----------------------|--------------|---|-----------------|
| 83 | ALL | ALL | ALL | 852500.0020 | REPLACEMENT LIP ACTUATION SPRING LINKAGE W/ HARDWARE KIT | |
| 84 | | | | | TUBE, SPRING ADJUSTMENT | 1 |
| 85 | | | | | BRACKET, SPRING ADJUSTMENT PIVOT | 1 |
| 87 | | | | | RING, RETAINING | 1 |
| 30 | | | | | FLAT WASHER, PLATED | 3 |
| 40 | | | | | NUT, HEX, PLATED | 1 |
| 88 | | | | | BOLT, HEX, PLATED | 1 |
| 70 | | | | | SHACKLE, GALV | 1 |
| 71 | | | | | CHAIN, LIP ACTUATION, PLATED | 1 |
| 86 | M68WD | ALL | 16" | 852251.0001* | SPRING, LIP ACTUATION,BLUE | 1 |
| | | | 18" | 852252.0001* | SPRING, LIP ACTUATION,GREEN | 1 |
| | | | 20" | 852253.0001* | SPRING, LIP ACTUATION,PURPLE | 1 |
| | M78WD | 30K / 35K | 16" | 852251.0001* | SPRING, LIP ACTUATION,BLUE | 1 |
| | | | 18" | 852252.0001* | SPRING, LIP ACTUATION,GREEN | 1 |
| | | | 20" | 852253.0001* | SPRING, LIP ACTUATION,PURPLE | 1 |
| | | 40K / 45K | 16" | 852252.0001* | SPRING, LIP ACTUATION,GREEN | 1 |
| | | | 18" | 852253.0001* | SPRING, LIP ACTUATION,PURPLE | 1 |
| | | | 20" | 852253.0001* | SPRING, LIP ACTUATION,PURPLE | 1 |

REPLACEMENT PARTS CONTINUED...

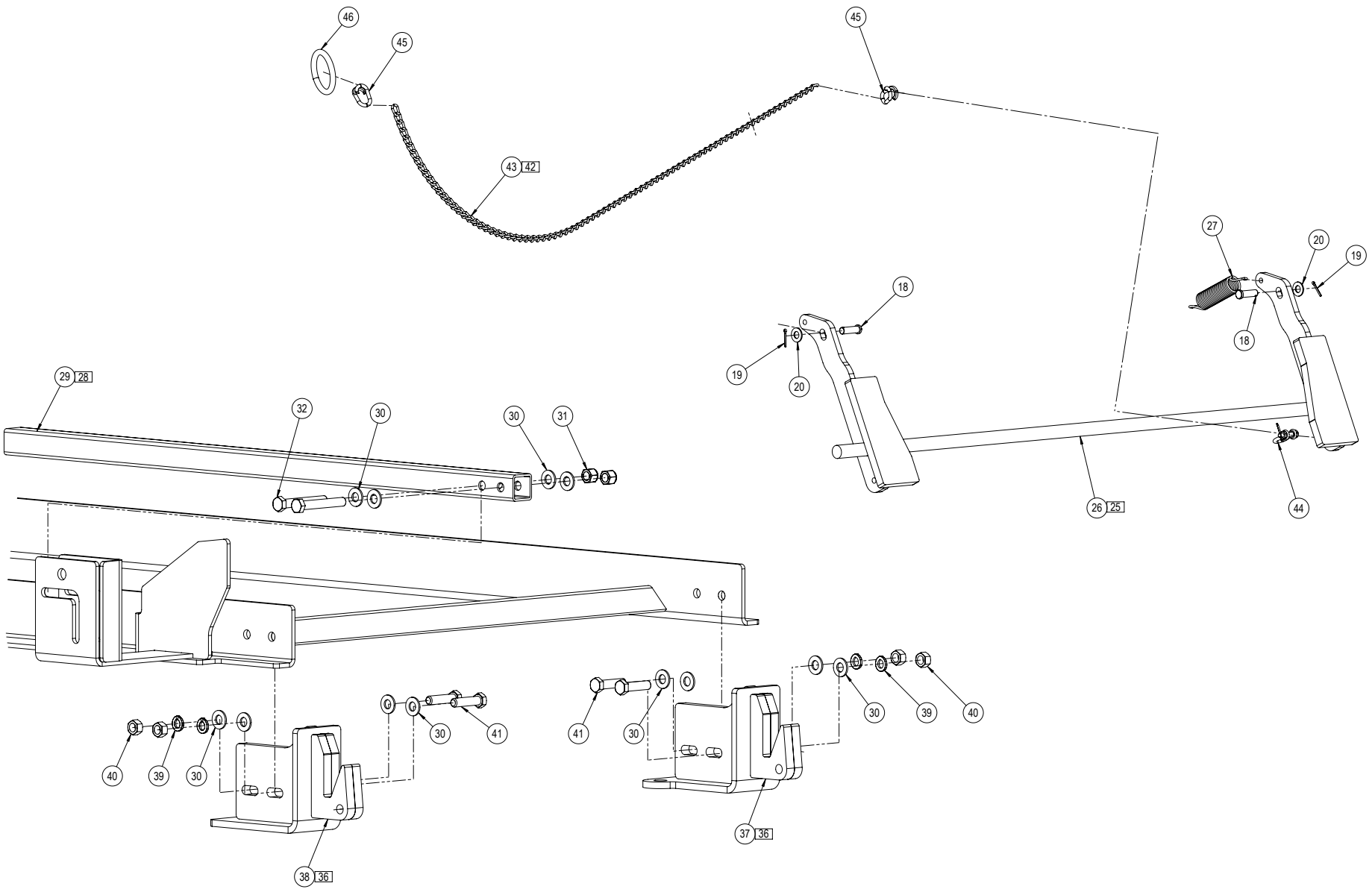

Figure 28

REPLACEMENT PARTS CONTINUED...

| SERVICE PARTS LISTS | | | | | | |
|---------------------|-------------------|----------------------------|----------------------|-------------|--|-----------------|
| ITEM # | MODEL # | CAPACITY (CIR) (POUNDS) | LIP SIZE (INCHES) | PART # | PART DESCRIPTION | QTY PER LEVELER |
| 25 | ALL | ALL | ALL | 852500.0004 | REPLACEMENT SAFETY LEG ASSY, W/HARDWARE KIT | |
| 26 | | | | | SAFETY LEGS | 1 |
| 27 | | | | | SPRING, EXTENSION | 1 |
| 18 | | | | | PIN, CLEVIS, PLATED | 2 |
| 19 | | | | | PIN, COTTER, PLATED | 2 |
| 20 | | | | | FLAT WASHER, PLATED | 2 |
| 28 | ALL | ALL | ALL | 852500.0005 | REPLACEMENT MAINTENANCE BRACE W/ HARDWARE KIT | |
| 29 | | | | | MAINTENANCE BRACE | 1 |
| 30 | | | | | FLAT WASHER, PLATED | 4 |
| 31 | | | | | NUT, HEX, NYLON LOCKING, PLATED | 2 |
| 32 | | | | | BOLT, HEX, PLATED | 2 |
| 2 | | | | | LABEL, CRUSH HAZARD, STRUT, MPL | 1 |
| 36 | ALL | ALL | ALL | 852500.0007 | REPLACEMENT LIP KEEPERS, 16IN LIP W/ HARDWARE KIT | |
| 37 | | | | | LIP KEEPER, 16IN LIP, RH | 1 |
| 38 | | | | | LIP KEEPER, 16IN LIP, LH | 1 |
| 30 | | | | | FLAT WASHER, PLATED | 8 |
| 39 | | | | | SPLIT WASHER, PLATED | 4 |
| 40 | | | | | NUT, HEX, PLATED | 4 |
| 41 | BOLT, HEX, PLATED | 4 | | | | |

REPLACEMENT PARTS CONTINUED...

| SERVICE PARTS LISTS | | | | | | |
|---------------------|---------|----------------------------|----------------------|-------------|--|-----------------|
| ITEM # | MODEL # | CAPACITY (CIR) (POUNDS) | LIP SIZE (INCHES) | PART # | PART DESCRIPTION | QTY PER LEVELER |
| 36 | ALL | ALL | ALL | 852500.0008 | REPLACEMENT LIP KEEPERS, 18IN LIP W/ HARDWARE KIT | |
| 37 | | | | | LIP KEEPER, 18IN LIP, RH | 1 |
| 38 | | | | | LIP KEEPER, 18IN LIP, LH | 1 |
| 30 | | | | | FLAT WASHER, PLATED | 8 |
| 39 | | | | | SPLIT WASHER, PLATED | 4 |
| 40 | | | | | NUT, HEX, PLATED | 4 |
| 41 | | | | | BOLT, HEX, PLATED | 4 |
| | | | | | | |
| 36 | ALL | ALL | ALL | 852500.0009 | REPLACEMENT LIP KEEPERS, 20IN LIP W/ HARDWARE KIT | |
| 37 | | | | | LIP KEEPER, 20IN LIP, RH | 1 |
| 38 | | | | | LIP KEEPER, 20IN LIP, LH | 1 |
| 30 | | | | | FLAT WASHER, PLATED | 8 |
| 39 | | | | | SPLIT WASHER, PLATED | 4 |
| 40 | | | | | NUT, HEX, PLATED | 4 |
| 41 | | | | | BOLT, HEX, PLATED | 4 |
| | | | | | | |
| 42 | ALL | ALL | ALL | 852500.0010 | REPLACEMENT SAFETY LEG PULL CHAIN W/ HARDWARE KIT | |
| 43 | | | | | CHAIN, TWISTED LINK | 1 |
| 44 | | | | | SHACKLE, GALV | 1 |
| 45 | | | | | LINK, BEND-CLOSE | 2 |
| 46 | | | | | RING | 1 |

REPLACEMENT PARTS CONTINUED...

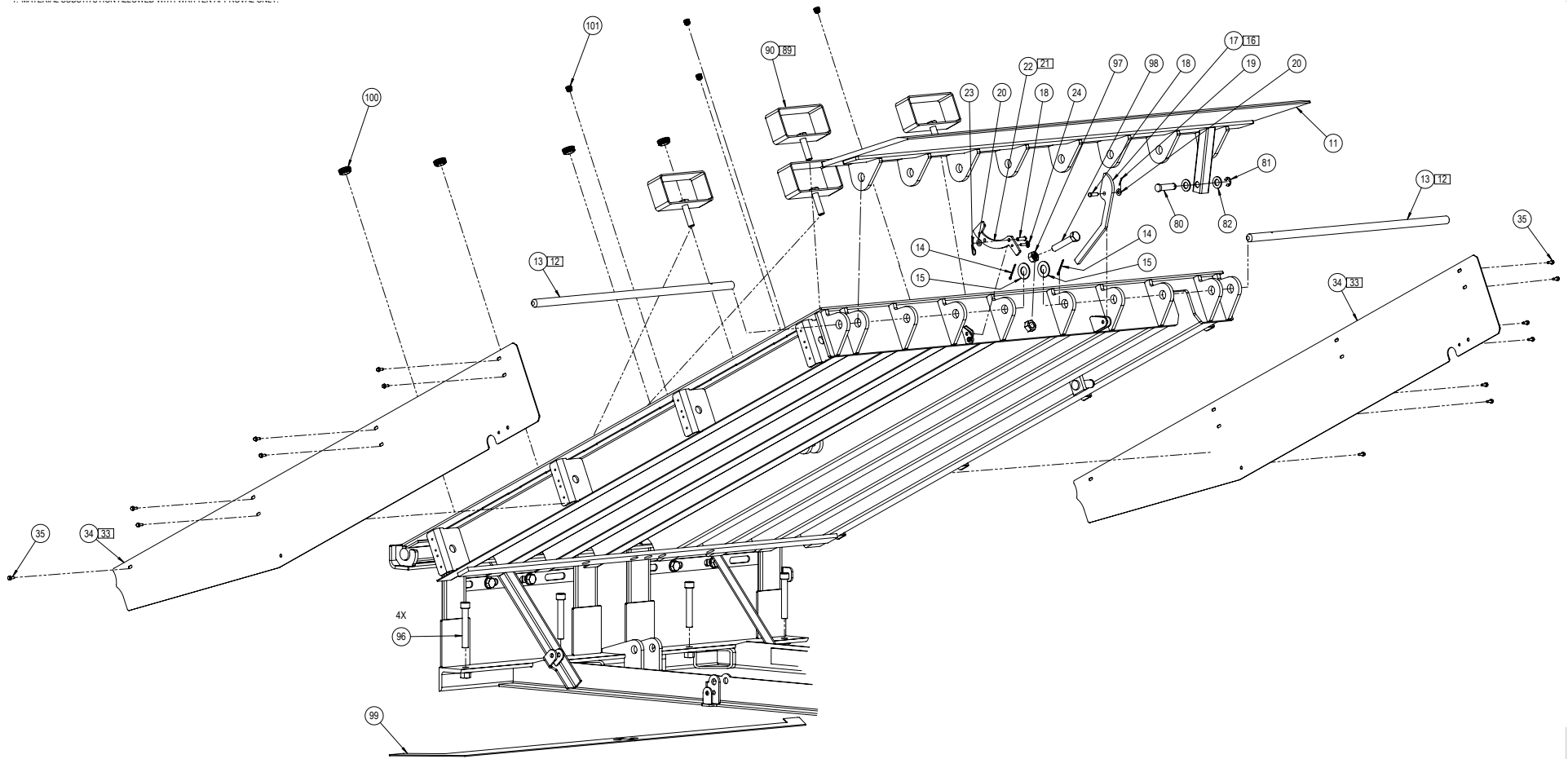

Figure 29

REPLACEMENT PARTS CONTINUED...

| SERVICE PARTS LISTS | | | | | | | |
|---------------------|---------|----------------------------|----------------------|-----------------------------|-----------------------------|-----------------|-----------------------------|
| ITEM # | MODEL # | CAPACITY (CIR) (POUNDS) | LIP SIZE (INCHES) | PART # | PART DESCRIPTION | QTY PER LEVELER | |
| 11 | M68WD | 30K | 16" | 852050.10721601 | LIP, 16"L,72"W,30K,NO TAPER | 1 | |
| | | | | 852050.10721801 | LIP, 18"L,72"W,30K,NO TAPER | | |
| | | | | 852050.10722001 | LIP, 20"L,72"W,30K,NO TAPER | | |
| | | 35K | 18" | 852050.1072160 | LIP, 16"L,72"W,35K,NO TAPER | | |
| | | | | 852050.1072180 | LIP, 18"L,72"W,35K,NO TAPER | | |
| | | | | 852050.1072200 | LIP, 20"L,72"W,35K,NO TAPER | | |
| | | 40K / 45K | 20" | 852050.1272160 | LIP, 16"L,72"W,45K,NO TAPER | | |
| | | | | 852050.1272180 | LIP, 18"L,72"W,45K,NO TAPER | | |
| | | | | 852050.1272200 | LIP, 20"L,72"W,45K,NO TAPER | | |
| | M78WD | 30K | 16" | 852050.10831601 | LIP, 16"L,83"W,30K,NO TAPER | 1 | |
| | | | | 852050.10831611 | LIP, 16"L,83"W,30K,TAPER | | |
| | | | | 18" | 852050.10831801 | | LIP, 18"L,83"W,30K,NO TAPER |
| | | | | | 852050.10831811 | | LIP, 18"L,83"W,30K,TAPER |
| | | | | 20" | 852050.10832001 | | LIP, 20"L,83"W,30K,NO TAPER |
| | | | | | 852050.10832011 | | LIP, 20"L,83"W,30K,TAPER |
| | | 35K | 16" | 852050.1083160 | LIP, 16"L,83"W,35K,NO TAPER | | |
| | | | | 852050.1083161 | LIP, 16"L,83"W,35K,TAPER | | |
| | | | | 18" | 852050.1083180 | | LIP, 18"L,83"W,35K,NO TAPER |
| | | | | | 852050.1083181 | | LIP, 18"L,83"W,35K,TAPER |
| | | | | 20" | 852050.1083200 | | LIP, 20"L,83"W,35K,NO TAPER |
| | | | | | 852050.1083201 | | LIP, 20"L,83"W,35K,TAPER |
| 40K / 45K | | 16" | 852050.1283160 | LIP, 16"L,83"W,45K,NO TAPER | | | |
| | | | 852050.1283161 | LIP, 16"L,83"W,45K,TAPER | | | |
| | | | 18" | 852050.1283180 | LIP, 18"L,83"W,45K,NO TAPER | | |
| | | | | 852050.1283181 | LIP, 18"L,83"W,45K,TAPER | | |
| | | | 20" | 852050.1283200 | LIP, 20"L,83"W,45K,NO TAPER | | |
| | | | | 852050.1283201 | LIP, 20"L,83"W,45K,TAPER | | |

REPLACEMENT PARTS CONTINUED...

| SERVICE PARTS LISTS | | | | | | |
|---------------------|---------|----------------------------|----------------------|-------------|---|-----------------|
| ITEM # | MODEL # | CAPACITY (CIR) (POUNDS) | LIP SIZE (INCHES) | PART # | PART DESCRIPTION | QTY PER LEVELER |
| 12 | M68WD | ALL | ALL | 852500.0001 | REPLACEMENT LIP HINGE SHAFTS W/ HARDWARE KIT | |
| 13 | | | | | SHAFT, LIP HINGE, 35.75IN | 2 |
| 14 | | | | | PIN, COTTER, PLATED | 2 |
| 15 | | | | | FLAT WASHER, PLATED | 2 |
| 12 | M78WD | ALL | ALL | 852500.0023 | REPLACEMENT LIP HINGE SHAFTS W/ HARDWARE KIT | |
| 13 | | | | | SHAFT, LIP HINGE, 41.25IN | 2 |
| 14 | | | | | PIN, COTTER, PLATED | 2 |
| 15 | | | | | FLAT WASHER, PLATED | 2 |
| 16 | ALL | ALL | ALL | 852500.0002 | REPLACEMENT LIP KICKOUT LEVELER W/ HARDWARE KIT | |
| 17 | | | | | LEVER, LIP KICKOUT | 1 |
| 18 | | | | | PIN, CLEVIS, PLATED | 1 |
| 19 | | | | | PIN, COTTER, PLATED | 1 |
| 20 | | | | | FLAT WASHER, PLATED | 1 |
| 21 | ALL | ALL | ALL | 852500.0003 | REPLACEMENT LIP MAINTENANCE BRACE W/HARDWARE KIT | |
| 22 | | | | | LIP MAINTENANCE BRACE | 1 |
| 18 | | | | | PIN, CLEVIS, PLATED | 1 |
| 23 | | | | | PIN, COTTER, PLATED | 1 |
| 20 | | | | | FLAT WASHER, PLATED | 1 |
| 24 | | | | | SCREW, THUMB | 1 |

REPLACEMENT PARTS CONTINUED...

| SERVICE PARTS LISTS | | | | | | |
|---------------------|---------|----------------------------|----------------------|---------------|-------------------------------------|-----------------|
| ITEM # | MODEL # | CAPACITY (CIR) (POUNDS) | LIP SIZE (INCHES) | PART # | PART DESCRIPTION | QTY PER LEVELER |
| 89 | ALL | ALL | ALL | 852500.0021 | DECK TRANSPORTATION LOOP KIT | |
| 90 | | | | | DECK TRANSPORTATION LOOP | 4 |
| 96 | ALL | ALL | ALL | 609431.12401* | SCREW, SOCKET HEAD CAP | 4 |
| 97 | ALL | ALL | ALL | 080356.1210 | NUT, HEX, PLATED | 1 |
| 98 | ALL | ALL | ALL | 604701.1232 | BOLT, HEX, PLATED | 1 |
| 99 | ALL | ALL | ALL | 852282.0001* | PLATE, LEVELING | 2 |
| 100 | ALL | ALL | ALL | 852334.0001* | PLUGS, DECK LARGE | 4 |
| 101 | ALL | ALL | ALL | 852334.0002* | PLUGS, DECK SMALL | 4 |
| 105 | ALL | ALL | ALL | 606699.0400 | PAINT,SPRAY,12OZ,DOCK GRAY | 1 |
| 106 | ALL | ALL | ALL | 606699.0401 | PAINT,BOTTLE,.5OZ w/BR,DOCK GRAY | 1 |

NOTE: * When PART # is ordered, quantity of 1 is shipped (not the QTY PER LEVELER).

REPLACEMENT PARTS CONTINUED...

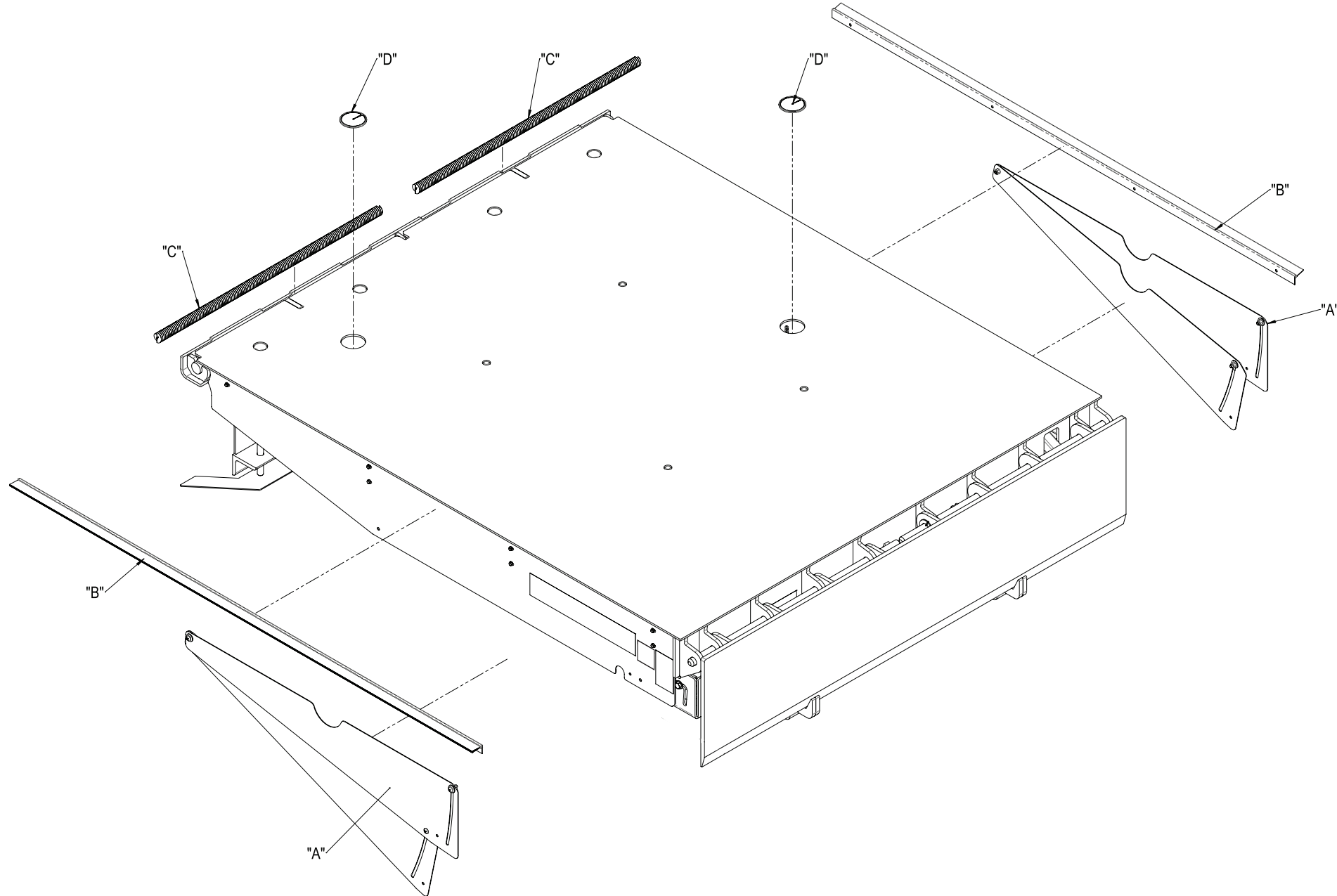

Figure 30

REPLACEMENT PARTS CONTINUED...

NOTE: Right and left hand is always determined from outside the building looking in.

| SERVICE PARTS LISTS | | | | | |
|---------------------|-------|-------------|-------------|-------------------------|-------------------------|
| ITEM | MODEL | PART # | | PART DESCRIPTION | STANDARD/OPTION |
| | | LH | RH | | |
| A | ALL | 852310.0001 | 852310.0002 | FULL RANGE TOE GUARDS | OPTION |
| B | ALL | N/A | | NONE | STANDARD |
| | | 852319.0001 | | SIDE SEAL (BRUSH) | OPTION 2 PER LEVELER |
| | | 852319.0002 | | SIDE SEAL (BRUSH) | OPTION 2 PER LEVELER |
| C | ALL | N/A | | NONE | STANDARD |
| | M68WD | 852332.0001 | | REAR SEAL (BRUSH) | OPTION 2 PER LEVELER |
| | M78WD | 852332.0003 | | REAR SEAL (BRUSH) | OPTION 2 PER LEVELER |
| D | ALL | N/A | | NONE | STANDARD |
| | | 852335.0001 | | CHAIN HOLE SEAL (BRUSH) | OPTION 2 PER LEVELER |

Limited Warranty

Wayne Dalton[™] Dock Mechanical Pit Leveler Limited Warranty

Wayne Dalton[®], a division of Overhead Door Corporation ("Seller") warrants to the original purchaser of Mechanical Pit Leveler ("Product"), subject to all of the terms and conditions hereof, that the Product and all components thereof will be free from defects in materials and workmanship under normal use for the following period, measured from the earlier of the date of installation by original purchaser or 60 days after shipping by Seller, provided that the owner maintains and operates the Product in accordance with the Owner's Manual.

- For the Product, Seller's warranty covers the repair or replacement of the Product or its components for a period of 12 months.
- The main spring has a limited prorated warranty for an additional 4 years following the 12-month warranty, for a total of 60 months.

Seller's obligation under this warranty is specifically limited to repairing or replacing, at its option, any part which is determined by Seller to be defective during the applicable warranty period. Repair or replacement labor for any defective Product part or component is included for a period of one (1) year from the date of installation. After that, any labor charges are excluded and will be the responsibility of the purchaser.

This warranty is made to the original purchaser of the Product only, and it is not transferable or assignable. This warranty does not apply to any unauthorized alteration or repair of the Product, or to any Product or component which has been damaged or deteriorated due to improper installation, improper operation, operation beyond capacity, misuse, neglect, accident, failure to provide necessary maintenance, normal wear and tear, or acts of God or any other cause beyond the reasonable control of Seller.

THIS WARRANTY IS EXCLUSIVE AND IN LIEU OF ANY OTHER WARRANTIES, EITHER EXPRESS OR IMPLIED, INCLUDING BUT NOT LIMITED TO ANY IMPLIED WARRANTY OF MERCHANTABILITY OR FITNESS FOR A PARTICULAR PURPOSE.

IN NO EVENT SHALL SELLER BE RESPONSIBLE FOR, OR LIABLE TO ANYONE FOR, SPECIAL, INDIRECT, COLLATERAL, PUNITIVE, INCIDENTAL OR CONSEQUENTIAL DAMAGES, even if Seller has been advised of the possibility of such damages. Such excluded damages include, but are not limited to, loss of goodwill, loss of profits, loss of use, cost of any substitute product, interruption of business, other similar indirect financial loss or arising out of or related to the use, installation or maintenance of the Product (including premature product wear, product failure, property damage or bodily injury resulting from use of unauthorized replacement parts or modification of the Product). Seller's sole obligation with regard to a Product that is claimed to be deficient in material or workmanship shall be as set forth in this Limited Warranty.

Claims under this warranty must be made promptly after discovery, within the applicable warranty period, and in writing to the Seller or to the authorized distributor or installer whose name and address appear below. The purchaser must allow Seller a reasonable opportunity to inspect any Product claimed to be defective prior to removal or any alteration of its condition. Proof of the purchase and/or installation date, and identification as the original purchaser, may be required.

MODEL: _____

ORIGINAL PURCHASER: _____

INSTALLATION ADDRESS: _____

DEALER: _____

DEALER'S ADDRESS: _____

FACTORY ORDER #: _____

DATE OF INSTALLATION: _____

SIGNATURE OF DEALER: _____