



# ***Installation Instructions for Foam Shelter MODEL TM70WD***



**READ COMPLETE INSTRUCTIONS BEFORE INSTALLING DOCK SEAL OR SHELTER**

# IMPORTANT SAFETY INSTRUCTIONS

## DEFINITION OF KEY WORDS USED IN THIS MANUAL:

### **⚠ DANGER**

INDICATES A HAZARDOUS SITUATION THAT, IF NOT AVOIDED, WILL RESULT IN DEATH OR SERIOUS INJURY.

### **⚠ WARNING**

INDICATES A HAZARDOUS SITUATION THAT, IF NOT AVOIDED, COULD RESULT IN DEATH OR SERIOUS INJURY.

### **⚠ CAUTION**

INDICATES A HAZARDOUS SITUATION THAT, IF NOT AVOIDED, COULD RESULT IN MINOR OR MODERATE INJURY.

### **NOTICE**

INDICATES INFORMATION CONSIDERED IMPORTANT, THAT IT IS NOT RELATED TO INJURY, BUT MAY RESULT IN PROPERTY DAMAGE.

**IMPORTANT:** Required key step for proper door operation.

**NOTE:** Information only.

# INSTALLATION LISTS

THE FOLLOWING LISTS COVER BASIC INSTALLATION

COMPONENT LIST	
DESCRIPTION	QTY.
VERTICAL PAD	2
HEADER CURTAIN	1
PRE-CUT ROPE [(1) LONG, (1) MEDIUM, (1) SHORT]	3
ROPE CLEAT	1
HARDWARE BOX	1

HARDWARE SUPPLIED LIST	
DESCRIPTION	QTY.
INSTALLATION INSTRUCTIONS	1
3/8" X 1-7/8" SLEEVE ANCHOR	17
NO. 14 WOOD SCREW	36
STEEL BRACKET, FLAT	6
STEEL BRACKET, ANGLE	6

RECOMMENDED TOOLS LIST (TYPICAL MASONRY WALL)			
DESCRIPTION	QTY.	DESCRIPTION	QTY.
CAULKING GUN	1	HAMMER DRILL	1
PENCIL OR MARKER	1	3/8" MASONRY DRILL BIT	1
TAPE MEASURE	1	HAMMER	1
CAULKING - OUTDOOR ACRYLIC TYPE	1	WELDING EQUIPMENT	1
LEVEL	1	1/2" SOCKET WRENCH	1
SQUARE	1	NO.3 ROBERTSON/PHILIPS DRIVER	1

# INSTALLATION INSTRUCTIONS

## ⚠ WARNING

**READ ALL INSTRUCTIONS BEFORE INSTALLING. WAYNE DALTON WILL NOT BE HELD RESPONSIBLE FOR IMPROPER INSTALLATION OF ANCHORING DEVICES OR FOR INSTALLATION INTO AGED OR UNSOUND CONCRETE, CONCRETE BLOCK, OR OTHER WALL OR FLOOR MATERIAL WHICH MAY RESULT IN PREMATURE PRODUCT WEAR, PRODUCT FAILURE, PROPERTY DAMAGE, OR PERSONAL INJURY.**

### 1. CHECK ORDER

- a. Measure door opening height and width.
  - Seal door opening varies according to dimensions of existing door.
  - Make sure dimensions match Purchase Order.
  - Make sure there is enough space to install shelter.
    - \* Check for existing:
      - Dock seals
      - Bollard and obstacles
      - Lights and conduit
      - Drains

**NOTE:** Make sure there is enough space between the door opening and the frames to install the mounting brackets on the inside of the shelter.

- b. Check Components List and Hardware Supplied List to make sure all listed are present (Page 1).
- c. Check Recommended Tools List and make sure all are available (Page 1).
- d. Determine method of mounting shelter to wall.
  - Three anchors per frame member recommended --one at centre, one near each end. Use more if necessary.
  - Super Seal supplies 3/8" x 1-7/8" sleeve anchors with the shelter. The customer must supply any other mounting hardware, including Steel Protective Guards.
  - Welding shelter to wall is **not** recommended.

Recommended Methods for:

1. **Concrete Block, Precast Concrete, or Brick Wall:** Use 3/8" x 1-7/8" expansion anchors. Use through-bolt fastening if anchors will not hold. 3/8" x 1-7/8" threaded rod recommended (supplied by others).
2. **Metal Siding:** Through-bolt fastening as above (supplied by others). Use a back-up plate (steel or wood) to support bolts. An other alternative is to use wood lags with back plate from inside the building to back of shelter.
3. **Steel Door Frame:** Weld brackets on face of building wall. Flush with inside perimeter in a manner in which the lip of the angle bracket will extend out from the building. This will allow for the welded portion to be hidden behind the side pads. In addition, this will allow easy access of No. 14 wood screws (see step 3A). An alternative is to use Tek-Screws.

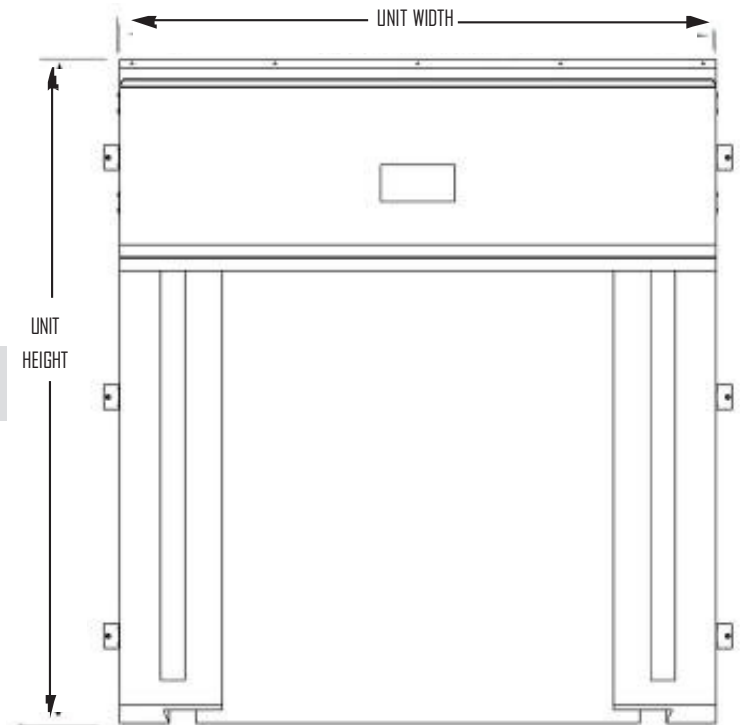

FIG 1

# INSTALLATION INSTRUCTIONS CONTINUED...

## 2. MARK CENTERLINE

- a. Finding the centre.
  - Locate centerline of door opening and mark on dock floor.
  - Mark centerline on lintel above door.
  - Measure head frame width and mark.
  - Take 1/2 the head curtain width and mark this distance on both sides of door's centerline (Fig. 2). This will determine the outside position of each vertical pad.
  - Draw a level line even with the dock floor along both sides of the dock face.

## 3. PREPARING VERTICAL PADS

- a. Determine left and right vertical pad.
  - Place face down on ground.
- B. Determine left and right vertical pad.
  - Mark and drill holes at centre as well as 12" from each end of the frame (Fig. 3).
  - Use at least three, three-hole mounting brackets per vertical frame per perimeter.
  - Fasten three FLAT brackets to the back INSIDE perimeter.
  - Fasten three ANGLE brackets to the back OUTSIDE perimeter.
  - Use information from Step. 2 and Fig. 2, determine position of vertical frame's bottom edges.
  - Make sure frames are plumb and square from bottom to top (Fig. 4, next page).
  - Fasten using 3/8" x 1-7/8" sleeve anchor bolts. Repeat for other pad.

**NOTE:** Final location of the bracket to be determined by the installer to suit spacing of the mortar joints or other wall configurations. Common location of brackets is one at centre and one 12" from each end (FIG. 3).

## 3A. IF MOUNTING WELD BRACKETS TO STEEL DOOR FRAME

- a. Steel door frame.

**NOTE:** It is not unusual to have a door jamb that is steel from the floor line to 3-4 feet up on the jamb.

1. Inside perimeter

- Weld to jamb. Be sure to "hide" the welding portion, but be sure to allow room for you to screw into the wood backing of the seal.
- Place upper two brackets: Drill a hole for 3/8" x 1-7/8" sleeve anchor near center and place upper two brackets. Be sure to allow room to screw into jamb. Secure with galvanized brackets (see 3).

2. Outside perimeter:

- Fasten the remaining brackets to the vertical pads.

3. If the door jamb is steel around the total perimeter of the jamb

- Weld a galvanized angle bracket at the center and at the top of the inside perimeter of the jamb following the same procedure as above.

**NOTE:** Final location of the bracket to be determined by the installer to suit spacing of the mortar joints or other wall configurations. Common location of brackets is one at centre and one 12" from each end (FIG. 3).

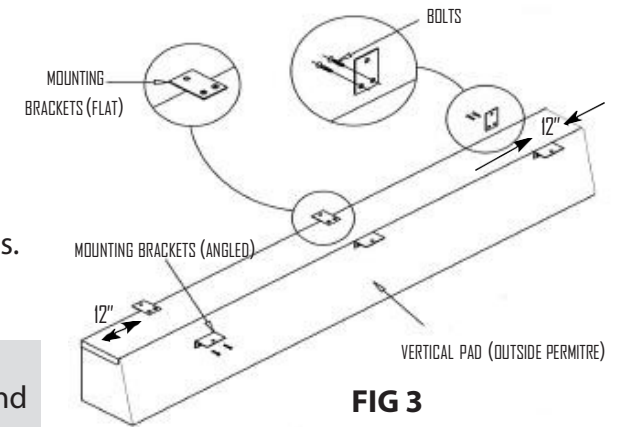
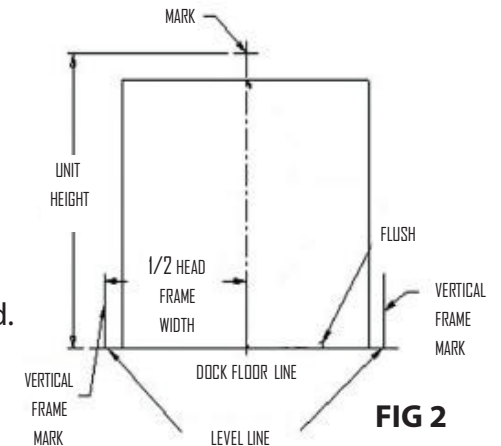

# INSTALLATION INSTRUCTIONS CONTINUED...

## 4. MOUNT VERTICAL PADS TO WALL

### a. Mount to wall.

- Taking the prepared pads, level the bottom of pads with dock floor or at the top of dock bumpers on low docks (Fig. 4).
- Level side pads from top to bottom.
- Bolt a 3/8" x 1-7/8" sleeve anchor through the middle angle bracket.
- Repeat a-c for remaining brackets.

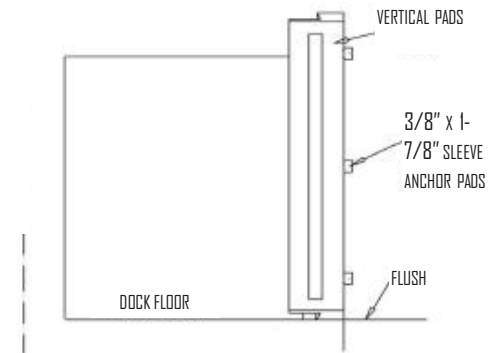

FIG 4

## 5. DROP CURTAIN PULL ROPES

- Lay Drop Curtain "B", face down on a clean surface.

### A. Attaching ropes.

- Feed pull ropes (3 different lengths) through the "D" rings and pulleys (Fig. 5).

**NOTE:** "D" rings and pulleys are sewn to the under side of fabric; therefore, lie the head curtain face down on the floor before proceeding.

**Step 1:** Attach shortest rope to first "D" ring at bottom of the curtain. Continue to feed rope through rest of "D" rings and through pulley.

**Step 2:** Repeat procedure for second longest rope.

**Step 3:** Repeat procedure for the longest rope.

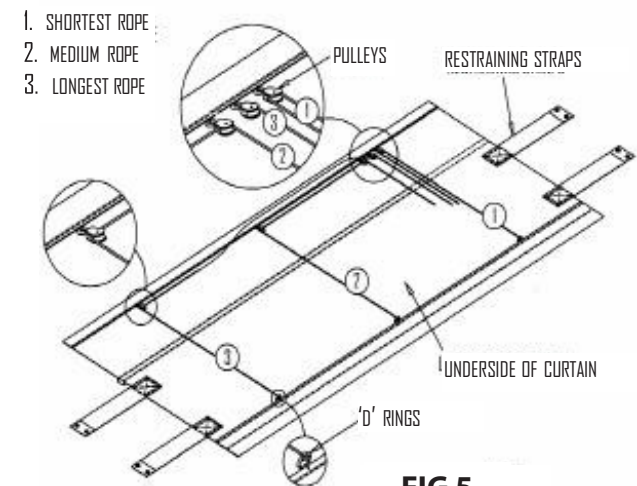

FIG 5

## 6. MOUNTING HEADER CURTAIN

### a. Preparing curtain: collect curtain with the attached flat bar.

### b. Attaching curtain to shelter.

- Fasten to wall using 3/8" x 1-7/8" sleeve anchor bolts at the marked hole locations.

**NOTE:** There are marks at the hole locations of the head curtain bar. Begin at centre and work outwards the ends.

- Each side of the header seal has one or two restraining strap(s) (Fig. 5) with two grommet holes each. These flaps should be mounted to the wood backing of the vertical seals using No. 14 wood screws.

## 7. MOUNT CLEAT

### a. Location (viewing from outside of door to inside):

**NOTE:** The curtain must remain in the up position until a truck has backed up to the bumper.

- Left jamb door opening, approximately 4 feet from dock floor.
- Tie the three pull ropes to the cleat insuring the header curtain operate smoothly in the down and up positions.

## 8. CAULK BETWEEN TOP OF THE HEADER CURTAIN AND WALL

- An outdoor acrylic type of caulking is recommended.