

## FIRESTAR® 700

INNOVATIVE SOLUTIONS TO SAFETY AND FIRE PROTECTION



### HIGH TRAFFIC SOLUTION WITH LASTING DURABILITY

Wayne Dalton's FireStar® 700 Rolling Steel Fire Door provides a practical and innovative solution to safety and fire protection. FireStar® doors can be drop-tested and reset at any time by anyone, thanks to a standard floor resettable feature.

The FireStar® 700 door features a forward-thinking design that outperforms industry standard fire doors in all areas, including easy testing capability; smooth, quiet operation; and reliable, long-lasting performance.

- STANDARD SIZES UP TO 24' WIDE AND 24' HIGH
- EASY TO TEST
- NON-TENSION RELEASE FLOOR RESETTABLE
- UL/ULC/FM RATED
- CONFORMS TO NFPA STANDARD 80

# FIRESTAR® 700

## STANDARD FEATURES OVERVIEW

### CONSTRUCTION

MAX WIDTH*	24' (7,315.2 mm)
MAX HEIGHT*	24' (7,315.2 mm)
MAX SQ. FOOT	324 sq. ft.
MATERIAL	Galvanized or Stainless Steel
CURTAIN	Galvanized steel curved or flat slats, primed gray, white beige or brown
OPERATION	Lift-up standard. Chain hoist included on sizes that require it
BOTTOM BAR	Two equal angles, 0.121" min thickness, to stiffen curtain
BRACKETS	Enclose ends of coil and provide support for counterbalance pipe at each end. Fabricate of steel plates with permanently sealed ball bearings
COUNTERBALANCE	Curtain to be correctly balanced by helical springs, oil tempered torsion type. Cast iron barrel plugs will be used to anchor springs to tension shaft and pipe. 20,000 cycle
HOOD	Minimum 24-gauge galvanized or stainless steel hood fabricated of sheet metal, flanged at top for attachment to header and flanged at bottom to provide longitudinal stiffness
FINISH	Rust inhibitive primer on non-galvanized surfaces and operating mechanisms. Guides and brackets will be coated with a flat black prime paint
OPERATOR OPTIONS	Chain Hoist with gear drive reduction, wall crank box, motor operation, motor operation with electrical sensing edge, motor operation with pneumatic sensing edge
RELEASE MECHANISM	FireStar release mechanism standard on doors up to 24'x24'
MOUNTING	Structural steel, drywall over wood stud jamb, drywall over 16-gauge steel stud jamb

### WARRANTY

TERMS	Twenty four (24) month limited warranty
-------	---

### OPTIONS

- Operation options: Chain hoist with gear drive reduction; awning crank; motor operation with electrical or pneumatic sensing edge
- FM label option to include hood with steel baffle
- Wind load options available
- Awning crank
- Motor operation
- Motor operation w/electrical or pneumatic sensing edge
- Viscous governor, if required by size of door
- 22-gauge hood

**FireStar® 700 Rolling Steel Fire Doors are a simple and innovative solution for your safety and fire protection needs.**

Critical elements necessary in the reliable function of fire doors are incorporated as standard features with FireStar's revolutionary design.

### MATERIALS AND CONSTRUCTION

The FireStar® door can be drop tested easily and reset in a matter of seconds at any time; no tools or service technicians are required.

FireStar's revolutionary design uses a patented planetary gear on the drop-out mechanism ensuring years of reliable service and drop-out performance.

The drop-out mechanism is designed to eliminate down time during drop testing while the viscous governor technology results in smoother, quieter door operation.

Factory tested and approved for a minimum of 20,000 cycles, the FireStar® door can be used and tested on a regular basis without concerns of premature failure.

FireStar® fire doors have been tested and approved to meet the requirements of well known agencies, such as Underwriters Laboratories of Canada and Factory Mutual, and conform to NFPA Standard 80.

Wayne Dalton incorporates one standardized component design for all FireStar® doors regardless of size, and utilizes fewer parts than other models. This helps to ensure more accurate installations and reduces the possibility of potential service calls in the future.

*\*Consult factory for larger sizes*

### FINISH OPTIONS

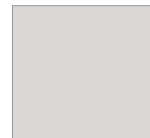

White



Gray



Beige



Brown

*Actual colors may vary from brochure due to fluctuations in the printing process. Always request a color sample from your Wayne Dalton dealer for accurate color matching.*

### CHAIN HOIST OPERATION

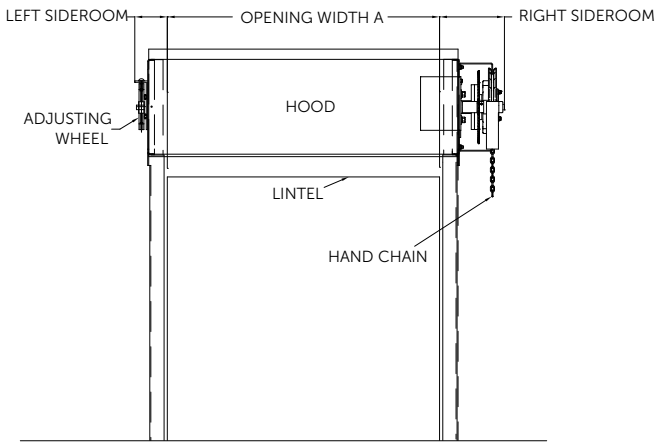

FRONT ELEVATION

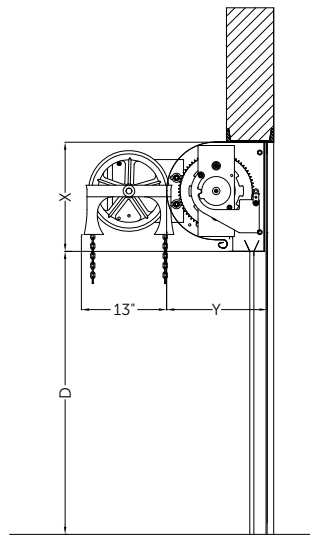

SIDE ELEVATION (UNDER LINTEL)

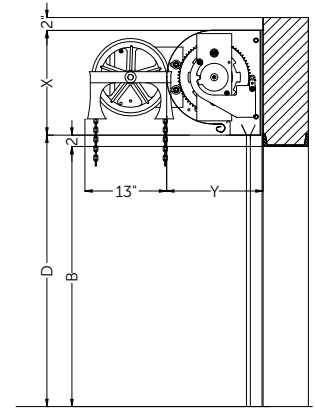

SIDE ELEVATION

### MOTOR OPERATION

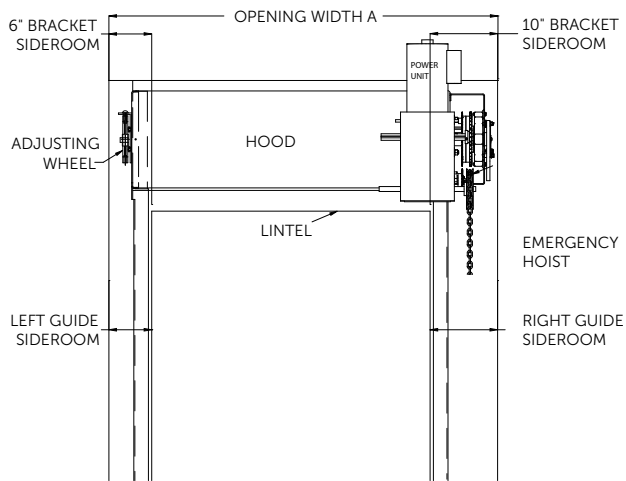

FRONT ELEVATION

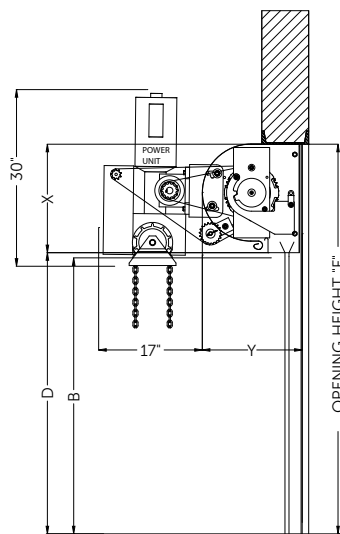

SIDE ELEVATION (UNDER LINTEL)

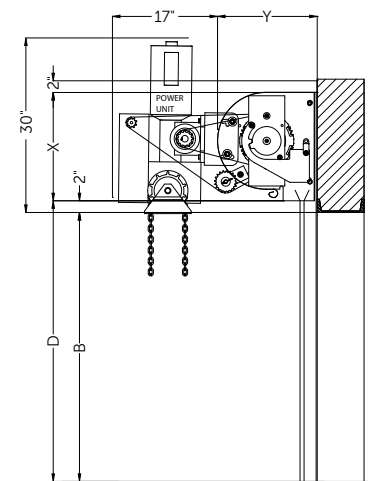

SIDE ELEVATION

### ANGLE GUIDES - FACE MOUNTED TO MASONRY



### ANGLE GUIDES - MOUNTED BETWEEN JAMBS

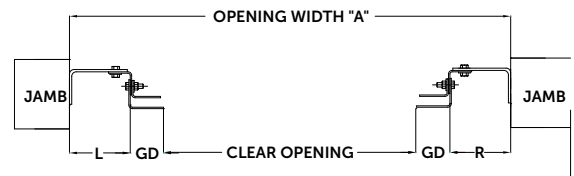

### ANGLE GUIDES - FACE MOUNTED TO STEEL



DOOR WIDTH	
GUIDE DIMENSION (GD)	WIDTH
2-7/8"	To 13'6" Width
2-13/16"	To 20'0" Width
3-1/4"	To 24'0" Width

NOTE: Dimensions are for general reference only and not for construction purposes.

# ROLLING STEEL FIRE DOORS

## CRANK OPERATION

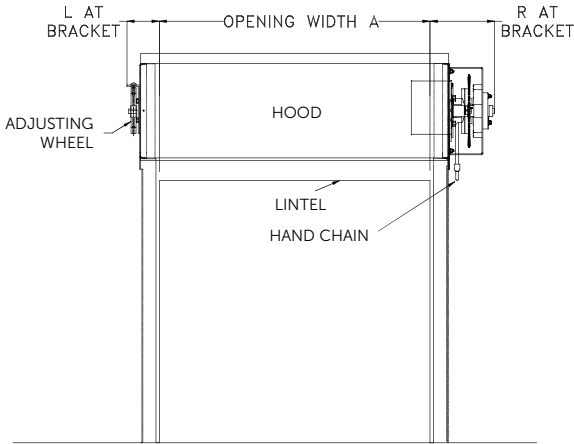

FRONT ELEVATION

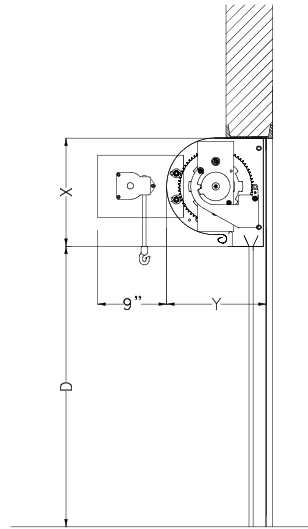

SIDE ELEVATION (UNDER LINTEL)

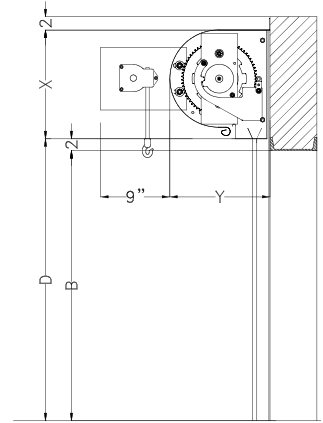

SIDE ELEVATION

## LIFT UP OPERATION - FRONT MOUNT

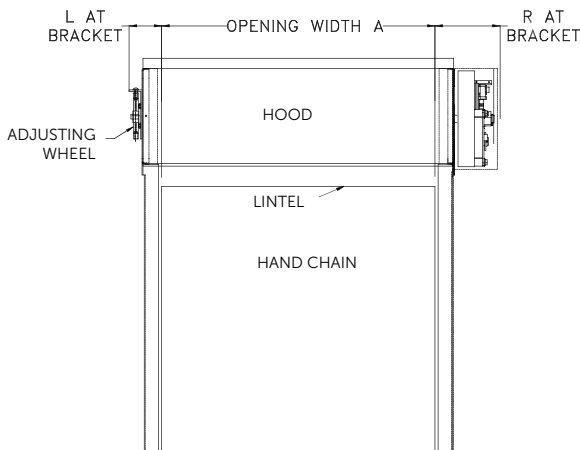

FRONT ELEVATION

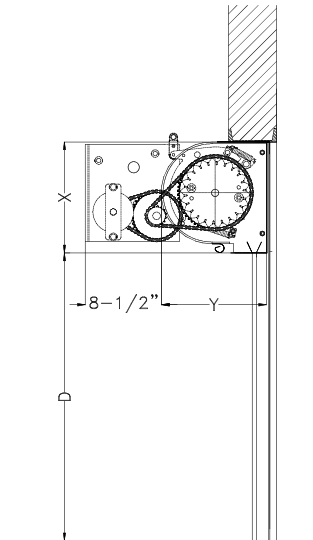

SIDE ELEVATION (UNDER LINTEL)

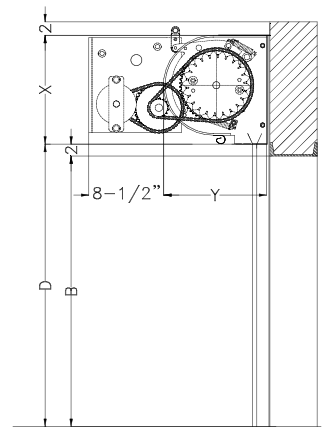

SIDE ELEVATION

## LIFT UP OPERATION - BOTTOM MOUNT

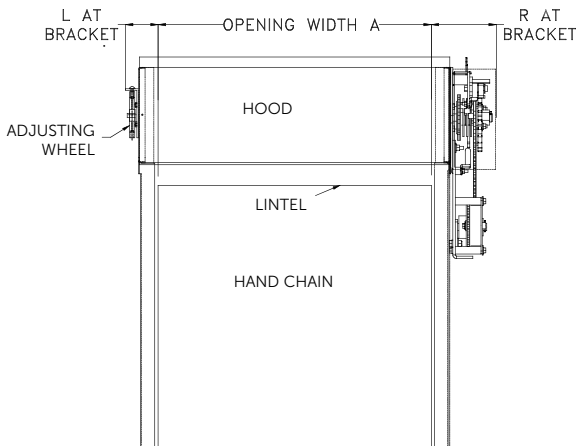

FRONT ELEVATION

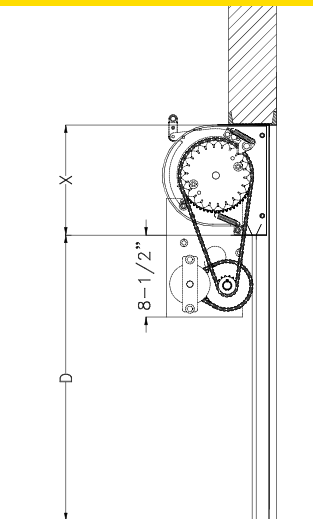

SIDE ELEVATION (UNDER LINTEL)

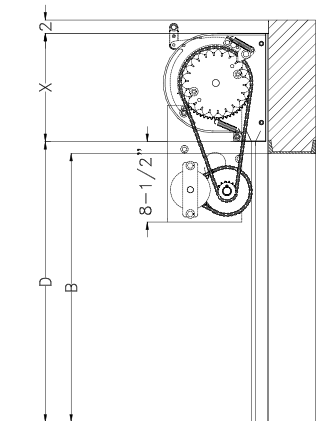

SIDE ELEVATION



*Test Device — FireStar® doors feature an easy-to-use release handle.*

**FIRESTAR® DOOR CONTROL DEVICES**

**Chain hoist, motor and crank operation**

- Revolutionary fire door control device utilizing a patented planetary gear arrangement to disconnect the operator and drop the door in the event of a fire.
- Easily drop test and reset a fire door without resetting spring tension and rerouting cables.

**Lift up operation**

- Revolutionary fire door control device utilizing clutch plates and unique counterbalance technology to drop the door in the event of a fire.

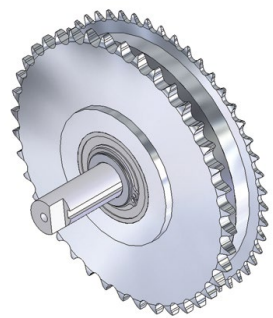

**SLAT PROFILES**

**No. 2 Slat Profile**



**Standard:**  
Curved-faced single crown slat  
**Available:**  
Up to 20-gauge steel  
Up to 20-gauge stainless steel  
**Pitch:** 1.9"

**No. 4 Slat Profile**



**Standard:**  
Curved-faced single crown slat  
**Available:**  
Up to 18-gauge steel  
Up to 18-gauge stainless steel  
**Pitch:** 2.8"

**No. 14 Slat Profile**



**Standard:**  
Flat-faced slat  
**Available:**  
Up to 18-gauge steel  
Up to 18-gauge stainless steel  
**Pitch:** 2.45"

**No. 17 Slat Profile**



**Standard:**  
Flat-faced slat  
**Available:**  
Up to 20-gauge steel  
Up to 20-gauge stainless steel  
**Pitch:** 1.6"

## FACE MOUNTED CHAIN HOIST/MOTOR/CRANK

WIDTH A	HEIGHT B (OPENING HEIGHT)															
	9'0"				9'1" TO 14'0"				14'1" TO 18'0"				18'1" TO 24'0"			
	BRACKET SIZE		SIDE ROOM		BRACKET SIZE		SIDE ROOM		BRACKET SIZE		SIDE ROOM		BRACKET SIZE		SIDE ROOM	
	X	Y	R	L	X	Y	R	L	X	Y	R	L	X	Y	R	L
<b>2" SLAT</b>																
Up to 20'0"	16-1/2"	15"	10"	6"	18-1/2"	17"	10"	6"	20"	19"	10"	6"	22"	21"	10"	6"
<b>3" SLAT</b>																
Up to 24'0"	16-1/2"	15"	10"	6"	20"	19"	10"	6"	22"	21"	10"	6"	24"	23"	10"	6"

NOTE: 24' height or 24' width or 400 sq. ft. max for 22 ga. Crank limits are 14' height or 12' width or 168 sq. ft.

## FACE MOUNTED-LIFT UP

WIDTH A	HEIGHT B (OPENING HEIGHT)			
	8'0"			
	BRACKET SIZE		SIDE ROOM	
	X	Y	R	L
<b>2" SLAT</b>				
Up to 10'0"	16-1/2"	15"	10"	8"
<b>3" SLAT</b>				
Up to 10'0"	18-1/2"	17"	10"	8"

NOTE:

Manual lift 2' Slat-up 10' wide or 8' high or 80 sq. ft.  
Manual lift 3' Slat-up 8' wide or 8' high or 80 sq. ft.

## BETWEEN JAMBS MOUNTED - UNDER LINTEL CHAIN HOIST/MOTOR/CRANK

WIDTH A	HEIGHT B (OPENING HEIGHT)															
	9'0"				9'1" TO 14'0"				14'1" TO 18'0"				18'1" TO 24'0"			
	BRACKET SIZE		SIDE ROOM		BRACKET SIZE		SIDE ROOM		BRACKET SIZE		SIDE ROOM		BRACKET SIZE		SIDE ROOM	
	X	Y	R	L	X	Y	R	L	X	Y	R	L	X	Y	R	L
<b>2" SLAT</b>																
Up to 20'0"	16-1/2"	15"	7-1/16"	9-1/16"	18-1/2"	17"	7-1/16"	9-1/16"	20"	19"	7-1/16"	9-1/16"	20"	19"	7-1/16"	9-1/16"
<b>3" SLAT</b>																
Up to 24'0"	16-1/2"	15"	7-1/16"	9-1/16"	18-1/2"	17"	7-1/16"	9-1/16"	22"	21"	7-1/16"	9-1/16"	24"	23"	7-1/16"	9-1/16"

NOTE: 24' height or 24' width or 400 sq. ft. max for 22 ga. Crank limits are 14' height or 12' width or 168 sq. ft.

## BETWEEN JAMBS MOUNTED-LIFT UP

WIDTH A	HEIGHT B (OPENING HEIGHT)			
	8'0"			
	BRACKET SIZE		SIDE ROOM	
	X	Y	R	L
<b>2" SLAT</b>				
Up to 10'0"	16-1/2"	15"	10"	6"
<b>3" SLAT</b>				
Up to 10'0"	18-1/2"	17"	10"	6"

 **Architect Resource**



Scan the QR code to go to our Architect Resource Center. In this tool, you will quickly find all of the specifications, drawings and documents you need for your project.

**Wayne  Dalton™**

DISTRIBUTED BY:

2501 S. State Hwy. 121 Bus., Ste 200  
Lewisville, TX 75067

[wayne-dalton.com](http://wayne-dalton.com)

