

SPECIFICATIONS	
DOCK NUMBER	
DOOR WIDTH	
DOOR HEIGHT	

NOTES

TEXTURED POWDER COATED DIAMOND PLATED SURFACE PROVIDES ENHANCED TRACTION AND INCREASE NON-SLIP PROTECTION.

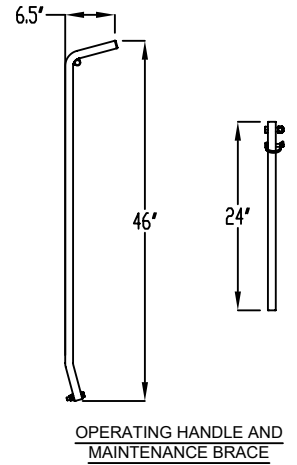
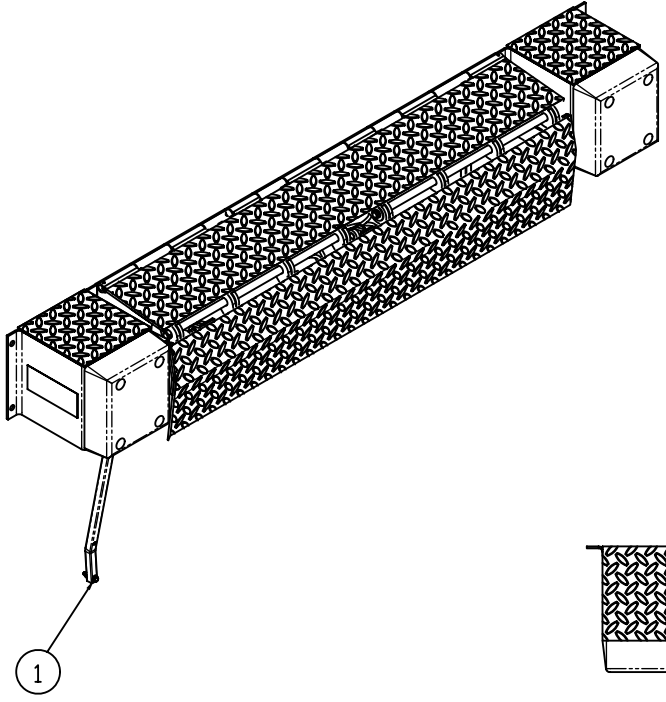

OPERATING HANDLE AND MAINTENANCE BRACE

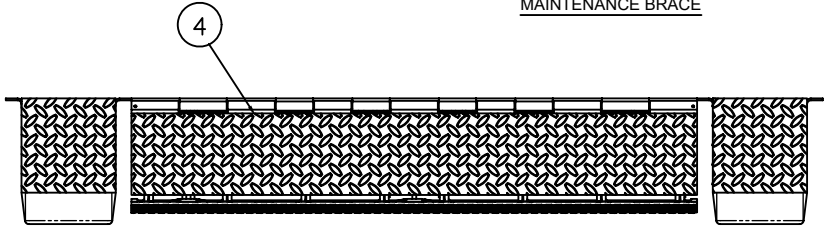

TOP VIEW

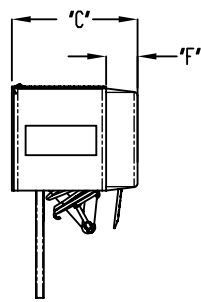

SIDE VIEW

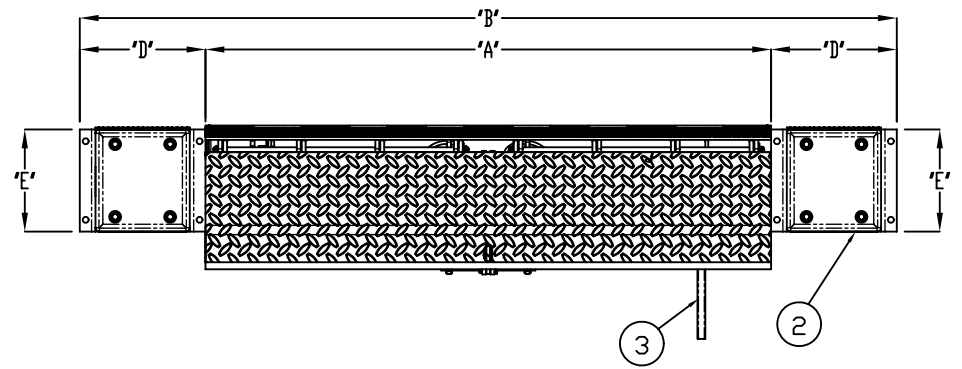

FRONT ELEVATION

- LEGEND:**
- 1. OPERATING HANDLE ASSEMBLY
 - 2. HEAVY-DUTY BUMPER BLOCKS AND MOLDED BUMPERS
 - 3. MAINTENANCE BRACE
 - 4. SAFETY TREAD

EOD LEVELER DIMENSIONS							
MODEL	DECK WIDTH (INCH)	OVERALL WIDTH (INCH)	BUMPER ASSEMBLY PROJECTION "C" (INCH)		BOX WIDTH (INCH)	BOX HEIGHT (INCH)	BUMPER THICKNESS (INCH)
			15" LIP	17" LIP			
			"A"	"B"			
E66R	66	98	16	17	16	13	4
E72R	72	104	16	17	16	13	4

EOD LEVELER ASSEMBLY	
PROJECT	
ARCHITECT	
CONTRACTOR	
DISTRIBUTOR	
PLANT	
DIST. DWG. NO.	DATE:
SHEET	BY:

